

# Cognex MVS-8000 Series

## MVS-8120 Hardware Manual

October 2006

The software described in this document is furnished under license, and may be used or copied only in accordance with the terms of such license and with the inclusion of the copyright notice shown on this page. Neither the software, this document, nor any copies thereof may be provided to or otherwise made available to anyone other than the licensee. Title to and ownership of this software remains with Cognex Corporation or its licensor.

Cognex Corporation assumes no responsibility for the use or reliability of its software on equipment that is not supplied by Cognex Corporation. Cognex Corporation makes no warranties, either express or implied, regarding the described software, its merchantability or its fitness for any particular purpose.

The information in this document is subject to change without notice and should not be construed as a commitment by Cognex Corporation. Cognex Corporation is not responsible for any errors that may be present in either this document or the associated software.

Copyright © 2006 Cognex Corporation  
All Rights Reserved  
Printed in U.S.A.

This document may not be copied in whole or in part, nor transferred to any other media or language, without the written permission of Cognex Corporation.

The hardware and portions of the software described in this document may be covered by one or more of the U.S. patents listed on the Cognex web site <http://www.cognex.com/patents.asp>. Other U.S. and foreign patents are pending.

The following are registered trademarks of Cognex Corporation:

acuCoder	acuFinder	acuReader	acuWin	BGAll	Checkpoint
Cognex	Cognex, Vision for Industry		CVC-1000	CVL	DisplayInspect
ID Expert	PastelInspect	PatFind	PatInspect	PatMax	PatQuick
PixelProbe	SMD4	Virtual Checksum	VisionLinx	VisionPro	VisionX

Other Cognex products, tools, or other trade names may be considered common law trademarks of Cognex Corporation. These trademarks may be marked with a "™". Other product and company names mentioned herein may be the trademarks of their respective owners.

# Contents

<b>Preface</b> .....	9
Style Conventions Used in This Manual .....	10
Cognex Offices .....	11
<b>Chapter 1: Cognex MVS-8120 Installation</b> .....	13
Installation Requirements .....	14
Host PC Requirements .....	14
Requirements for Maximum Frame Rate .....	14
PCI 2.1 Compliance .....	15
Installing MVS-8120 Internal Hardware .....	16
Placement of Internal Hardware .....	16
Summary of Installing Internal Components .....	17
Installing the MVS-8120 Frame Grabber .....	17
Installing Parallel I/O (PIO) Boards .....	19
Installing the Universal PIO (UPIO) Board .....	20
Installing the Standard Configuration UPIO Board .....	21
Installing the Light Control UPIO Board .....	22
Installing the External UPIO Board .....	24
Installing One ISA PIO Board .....	24
Installing Two ISA PIO Boards .....	26
Closing the System .....	27
Installing MVS-8120 External Hardware .....	28
<b>Chapter 2: Cognex MVS-8120 Hardware Description</b> .....	31
MVS-8120 Components .....	32
PCI Bus Interface .....	32
Input Video System .....	32
Parallel I/O .....	32
Video Output .....	32
Mechanical Specifications .....	34
Layout .....	34
Environmental Requirements .....	35
Shipping .....	35
Standards .....	35
Electrical Specifications .....	36
MVS-8120 Power Requirements .....	36
Parallel I/O Port .....	37
Parallel I/O Port Pin Numbering .....	37
Parallel I/O Port Pinout .....	37
Parallel Input (Trigger) Lines .....	38
Parallel Output Lines .....	39

## ■ Contents

---

Parallel Bidirectional Lines .....	39
Opto-Isolated Output (Strobe) Lines .....	40
Using Optically Isolated Outputs .....	40
Hardware Triggering of Acquisitions and Strobes .....	41
Available Acquisition Channels .....	42
<b>Chapter 3: Parallel I/O Boards .....</b>	<b>43</b>
Cognex Parallel I/O Board Options .....	44
Check Software Release Notes .....	46
Determining Line Numbering .....	46
Associate Trigger and Strobe with Camera Port .....	47
Software Line Numbering .....	48
Using Bidirectional Lines as Outputs .....	48
Universal Parallel I/O Board .....	49
Layout .....	50
Board Placement Considerations .....	51
Environmental Requirements .....	51
Power Requirements .....	51
Baseboard Parallel I/O Connector .....	52
Main (DB-26F) Parallel I/O Port .....	52
Cable 300-0287 .....	53
Cable 300-0274 .....	54
Auxiliary (HD-15F) Parallel I/O Port .....	54
Cable 300-0288 .....	55
Cable 300-0289 .....	56
Standard UPIO Configuration .....	56
Standard Configuration: Cable Pinouts .....	57
Standard Configuration: Pinout of Cable 300-0287 .....	57
Standard Configuration: Pinout of Cable 300-0288 .....	59
Standard Configuration: Port Pinouts .....	60
Standard Configuration: Pinout of DB-26F Port .....	60
Standard Configuration: Pinout of HD-15F Port .....	61
Light Control UPIO Configuration .....	62
Light Power Source and Fuses .....	63
Light Power Indicator LEDs .....	63
OPTO/TTL Trigger Selection Jumper .....	64
Light Control Configuration: Cable Pinouts .....	64
Light Control Configuration: Pinout of Cable 300-0287 .....	65
Light Control Configuration: Pinout of Cable 300-0289 .....	67
Light Control Configuration: Port Pinouts .....	68
Light Control Configuration: Pinout of DB-26F Port .....	68
Light Control Configuration: Pinout of HD-15F Port .....	69
External UPIO Configuration .....	70
External Configuration: Cable Pinouts .....	71

External Configuration: Pinout of External I/O Module .....	71
External Configuration: Pinout of Cable 300-0288 .....	72
External Configuration: Port Pinouts .....	72
External Configuration: Pinout of DB-26F Port .....	73
External Configuration: Pinout of HD-15F Port .....	73
Screw Terminal Connectors .....	74
Parallel I/O Circuit Logic .....	75
External I/O Module .....	76
Layout .....	76
Installation .....	77
Signal Lines .....	78
Mechanical and Electrical Specifications .....	78
LED Numbering .....	79
Input Terminal Block .....	80
Output Terminal Block .....	81
External I/O Module Adds Conversion Delay .....	82
External I/O Module Circuit Logic .....	83
ISA Parallel I/O Boards .....	85
Pinout Values for TTL Board .....	87
Pinout Values for OPTO/TTL Board .....	88
<b>Chapter 4: Cognex Video Modules and Cameras .....</b>	<b>89</b>
Cognex Video Module Overview .....	90
CVM Features .....	90
Video Input Capabilities .....	90
CVM Connector Panels .....	91
CVM Video Output .....	92
Bus-Based Video Output .....	92
CVM Descriptions .....	93
CVM1 Description .....	93
CVM1 Camera Support .....	93
CVM1 Analog Camera Port .....	93
CVM1 Line Numbering .....	94
CVM4 Description .....	96
CVM4 Camera Support .....	96
CVM4 Camera Port .....	96
CVM4 Line Numbering .....	97
CVM6 and CVM9 Description .....	98
CVM6 and CVM9 Camera Support .....	98
CVM6 and CVM9 Analog Camera Port .....	98
CVM6 and CVM9 Digital Camera Port .....	99
CVM 6 and CVM9 Line Numbering .....	100
CVM11 Description .....	102

## ■ Contents

---

CVM11 Camera Support .....	102
CVM11 Camera Port .....	102
CVM11 LEDs .....	104
CVM11 Line Numbering .....	104
Using Encoders .....	105
Encoders and CVM11 .....	106
Encoder Characteristics .....	106
Matching Encoders to CVM11 .....	107
Relationship Between Encoder and Camera Channels .....	108
CVM11 Encoder Port .....	108
CVM11 Encoder Cables .....	109
Connecting Cameras .....	111
Cognex Camera Cables .....	111
Optional Camera Lenses .....	111
Attaching Cameras to the CVM Breakout Box .....	112
Auxiliary Power Supply for Breakout Box .....	113
Attaching the Camera Breakout Cable .....	114
Auxiliary Power Supply for Breakout Cable .....	115
Hirose Connector Pinout .....	116
Configuring Cameras .....	119
Configuring Basler A101/A101P/A113P Cameras .....	119
Configuring Basler L103-2k Cameras .....	121
Connecting and Configuring Basler L401k Cameras .....	122
Connecting Cognex CVC-1000 Cameras .....	123
CVC-1000 Usage Notes .....	124
CVC-1000 Specifications .....	125
CVC-1000 Video Signal Timing .....	126
Connecting Dalsa Spyder Line Scan Cameras .....	127
Connecting Hitachi KP-F100 Digital Cameras .....	127
Required Switch Settings for Hitachi KP-F100 .....	127
Hitachi KP-F100 Usage Notes .....	128
Cable Connections for Hitachi KP-F100 .....	129
Power Supply for Hitachi KP-F100 .....	130
Configuring JAI CV-A1-14.4 Cameras .....	131
Configuring Pulnix TM-9701 Cameras .....	133
Configuring Sony XC-55 Cameras .....	133
Configuring Sony XC-ES50 Cameras .....	134
Configuring Sony XC-ST50 Cameras .....	135
Configuring Teli CS8531 Cameras .....	136
Camera I/O Electrical Specifications .....	137
Analog Video Input Circuit .....	137
Analog Video Signal Timing .....	138
Digital Camera I/O Circuit .....	139

**Index** ..... 141

## ■ Contents

---

# Preface

---

This manual describes the Cognex MVS-8120 frame grabber. This manual has the following chapters:

- *Cognex MVS-8120 Installation* on page 13 describes how to configure and install the MVS-8120.
- *Cognex MVS-8120 Hardware Description* on page 31 describes the MVS-8120 in detail, including environmental and power requirements, mechanical and electrical specifications, and the electrical interface.
- *Cognex Video Modules and Cameras* on page 89 describes the CVMs available for the MVS-8120 and how to connect compatible cameras.
- *Parallel I/O Boards* on page 43 describes the parallel I/O boards available for the MVS-8120.

## Style Conventions Used in This Manual

This manual uses the following style conventions:

<b>boldface</b>	Used for programming keywords, function names, class names, structures, enumerations, types, and macros. Also used for user interface elements such as button names, dialog box names, and menu choices.
<i>italic</i>	Used for names of variables, data members, arguments, enumerations, constants, program names, file names. Used for names of books, chapters, and sections. Occasionally used for emphasis.
<code>courier</code>	Used for programming code examples and for examples of program output.
<b>bold courier</b>	Used in illustrations of command sessions to show the commands that you would type.
< <i>italic</i> >	When enclosed in angle brackets, used to indicate keyboard keys such as <Tab> or <Enter>.

# Cognex Offices

Cognex Corporation serves its customers from the following locations:

Corporate Headquarters

Cognex Corporation  
Corporate Headquarters  
One Vision Drive  
Natick, MA 01760-2059  
(508) 650-3000

Web Site

[www.cognex.com](http://www.cognex.com)

## ■ Preface

---

# Cognex MVS-8120 Installation

# 1

This chapter describes how to install Cognex MVS-8120 frame grabbers and hardware components in a host PC.

This chapter contains the following sections:

- *Installation Requirements* on page 14 provides an overview of how to install a Cognex MVS-8120 frame grabber in a PC.
- *Installing MVS-8120 Internal Hardware* on page 16 provides considerations and procedures for installing the MVS-8120 system components in a PC.
- *Installing MVS-8120 External Hardware* on page 28 gives a summary of the installation steps for, and shows where to find further information about, the connection of cameras, triggers, strobes, and other devices to the MVS-8120.

# Installation Requirements

The Cognex MVS-8120 frame grabber is a 32-bit PCI bus card that you install in an available PCI slot with 5 V PCI signaling. The MVS-8120 frame grabber requires +5 V, +12 V, and -12 V DC voltages.

## Host PC Requirements

To install the MVS-8120, the host PC must meet the following minimum requirements:

- The motherboard's chip set must be fully compliant with the PCI specification, version 2.1 or later
- One available two-thirds length PCI slot for the MVS-8120
- One or two available short-length ISA slots if you will use the ISA parallel I/O adapters, or one slot position of any type if you will use the universal parallel I/O adapter
- A CD-ROM drive, or access to one over a network, to install the Cognex software.

Additional requirements may be imposed by your Cognex software package. Check your Cognex software's release notes for the software's requirements, if any, on:

- Minimum recommended CPU speed
- Host operating system, including the supported service pack release level
- Supported video cards
- Desktop color depth (the number of colors displayable)
- Desktop size (the number of pixels displayable in width and height on your screen)
- The presence of a mouse or other pointing device

## Requirements for Maximum Frame Rate

The MVS-8120 displays video output under control of the host PC's operating system. The MVS-8120 frame grabber generates high resolution bitmaps and passes them through the PCI bus for display on a high resolution SVGA display.

Cognex software can transfer images from the MVS-8120 in two ways:

- From the MVS-8120 to system memory, and from there to the video display adapter
- Directly from the MVS-8120 to the video display adapter using PCI bus DMA transfers

To support the DMA transfer method, the host PC and its video display adapter must meet the following requirements:

1. The PCI chipset on the host PC's motherboard must be fully compliant with the PCI 2.1 specification. This is discussed further in *PCI 2.1 Compliance* below.
2. The video display adapter and its device driver must be fully compliant with Microsoft's DirectX specification, version 3.0 or later, and the adapter must support hardware blitting.
3. The video display adapter must supply sufficient offscreen video memory to allow hardware blitting of the display image. An adapter with 4 or more MBytes of video memory meets this requirement.
4. If your host PC has more than one PCI bus, the display adapter should be on the same bus as the MVS-8120.
5. The PCI bus must not be saturated with requests from competing PCI adapters, such as network or SCSI cards.

Contact your Cognex sales engineer for recommendations on video display adapters to work with your MVS-8120.

## PCI 2.1 Compliance

To support the DMA transfer of images from the MVS-8120 to the video display adapter, your host PC's motherboard must meet the specifications in the publication *PCI Local Bus Specification Revision 2.1* (or a later revision).

Most post-1996 motherboards implementing support for both EIDE hard disk control and the Plug and Play specification will meet the PCI 2.1 specification. Motherboards with chip sets that support Intel Pentium MMX, Celeron, Pentium II, Pentium III, Pentium 4, and Xeon CPUs, and AMD K6-2 and Athlon CPUs, are known to be compliant.

# Installing MVS-8120 Internal Hardware

This section describes how to install and connect the Cognex MVS-8120 frame grabber and hardware components.

## Placement of Internal Hardware

The MVS-8120 frame grabber is a short length PCI card as defined in the PCI specification. You can orient the MVS-8120 system in any direction, but you must ensure that the orientation does not cause heat buildup or airflow restrictions that would result in overheating.

Figure 1 shows the placement of components for a typical MVS-8120 frame grabber system.

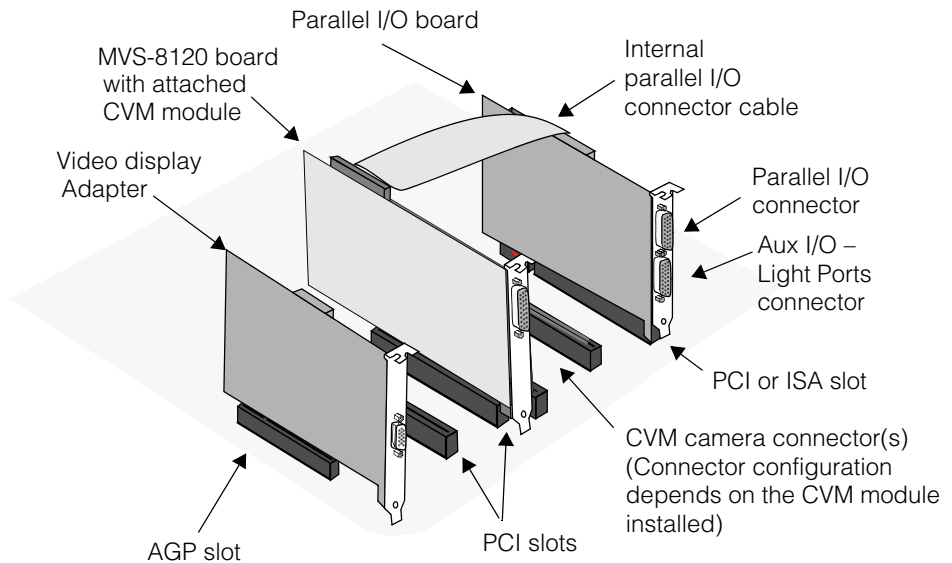

Figure 1. MVS-8120 system typical component placement

## Summary of Installing Internal Components

Table 1 provides a summary of the steps to install the MVS-8120 internal components.

Component	Installation Location
Cognex MVS-8120 frame grabber	Insert in an available PCI slot on the PC motherboard. (See <i>Installing the MVS-8120 Frame Grabber</i> on page 17.)
Parallel I/O board(s)	Insert the optional parallel I/O board(s) in slots or slot positions on the PC motherboard and connect the ribbon cable to the MVS-8120. (See <i>Installing Parallel I/O (PIO) Boards</i> on page 19.)

Table 1. *Installing MVS-8120 internal components*

## Installing the MVS-8120 Frame Grabber

The MVS-8120 frame grabber installs into a PCI bus slot of the host computer. Figure 1 on page 16 shows its location in a typical system. Figure 2 shows the components and connectors of the MVS-8120.

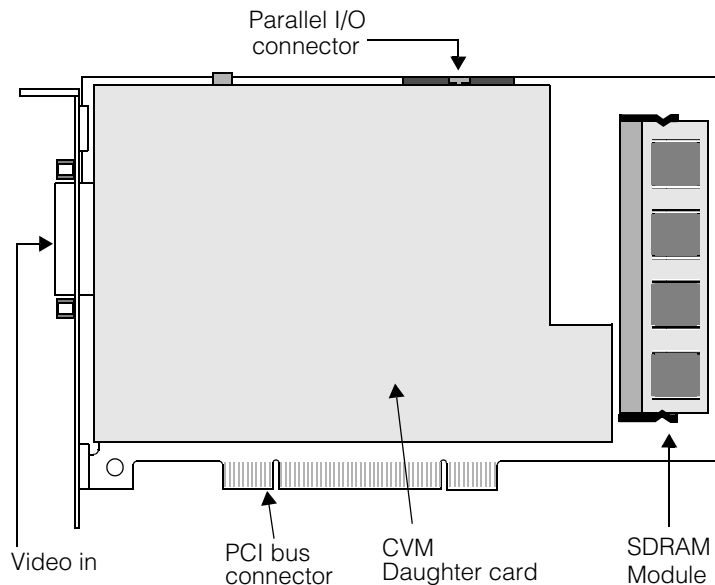

Figure 2. *MVS-8120 components and connectors*

**Caution**      *Electrostatic discharge (ESD) can damage the electronic components of your Cognex hardware.*

To install the MVS-8120 frame grabber in your PC:

1. Wear a grounded, static-dissipating wrist strap for ESD protection.
2. Turn off the host PC and remove its cover.
3. Check your MVS-8120's board revision by looking at the lettering along the edge of the board. If your MVS-8120's board revision is C or later, skip this step.

MVS-8120's with circuit board revision C or later are qualified for universal signaling and can be installed in any PCI slot. MVS-8120's with circuit board revision A or B must be installed in a 5 V PCI slot. For A or B revision boards, identify your PC's PCI slot types as shown Table 2 and in Figure 3 on page 19. Place your MVS-8120 only in a slot that supports 5 V signaling.

Motherboard PCI slots are keyed to allow acceptance of boards that use either 5 V or 3.3 V signalling. The bus connectors on all PCI boards are slotted to disallow placement of the board in the wrong type of slot, as described in the following table and diagram.

<b>PCI Slot Type</b>	<b>Key in PCI Slot</b>
Supports 3.3 volt boards	Key is towards the back of the PC
Supports 5 volt boards	Key is towards the front of the PC

*Table 2. PCI slot types*

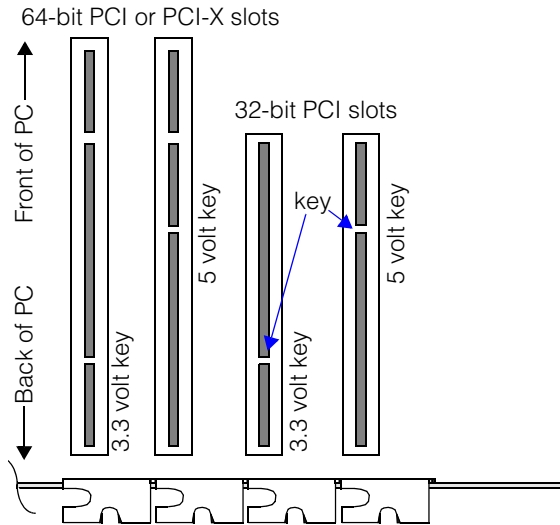

Figure 3. PCI slot types

4. Insert the MVS-8120 in an available PCI slot and secure it to the back panel with the mounting screw.
5. Connect cameras as required to the MVS-8120 *before* turning on the PC's power.
6. If you are installing a parallel I/O option board, continue with the steps in *Installing Parallel I/O (PIO) Boards* on page 19.
7. If you are not installing a parallel I/O board, turn on the PC's power and test as required before continuing.
8. Close your PC as described in *Closing the System* on page 27.

## Installing Parallel I/O (PIO) Boards

The MVS-8120 supports the following parallel I/O board configurations. See *Cognex Parallel I/O Board Options* on page 44 for an explanation of the difference between the universal and ISA parallel I/O board categories.

- To install the universal parallel I/O board in its standard configuration, see both *Installing the Universal PIO (UPIO) Board* in the next section and *Installing the Standard Configuration UPIO Board* on page 21.
- To install the universal parallel I/O board in its light control configuration, see both *Installing the Universal PIO (UPIO) Board* in the next section and *Installing the Light Control UPIO Board* on page 22.

- To install the universal parallel I/O board in its external configuration, see both *Installing the Universal PIO (UPIO) Board* in the next section and *Installing the External UPIO Board* on page 24.
- To install one ISA parallel I/O board, see *Installing One ISA PIO Board* on page 24.
- To install the two board configuration of the ISA parallel I/O boards, see *Installing Two ISA PIO Boards* on page 26.

For part numbers, pinouts, and specifications for the parallel I/O boards, refer to *Chapter 3, Parallel I/O Boards*, on page 43.

## Installing the Universal PIO (UPIO) Board

All configurations of the universal parallel I/O board use the 12 inch (30.5 cm) ribbon cable supplied with the board, as shown in Figure 4. The cable has a 40-pin connector on each end, and its connectors are keyed to ensure that they are inserted correctly.

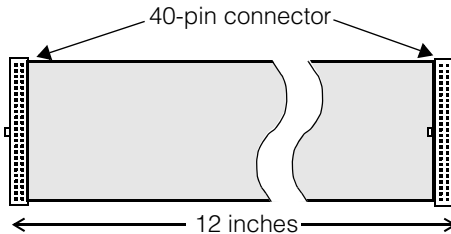

Figure 4. Parallel I/O board 12-inch ribbon cable (P/N 300-0132)

Using Figure 9 on page 25 for reference, follow these steps to install all configurations of the universal parallel I/O board:

1. Wear a grounded, static-dissipating wrist strap for ESD protection.
2. Turn off the PC and remove its cover.
3. Consider the information in *Board Placement Considerations* on page 51, and make sure your board does not conflict with an adjacent ISA-based board. If you are using a low profile PC that uses a riser card for slot positions, test the fit of the parallel I/O board with the PC's cover closed.
4. Install the universal parallel I/O board in any available slot position. Note that this board does not connect to a bus slot in the PC. Secure a mounting screw through the board's mounting bracket to the PC's back panel.

- Connect the external power cable, Cognex P/N 300-0175, between connector J4 on the universal parallel I/O board and a +12 V power source on the host PC, as shown in Figure 5. The cable connectors are keyed so that they will only fit the correct way.

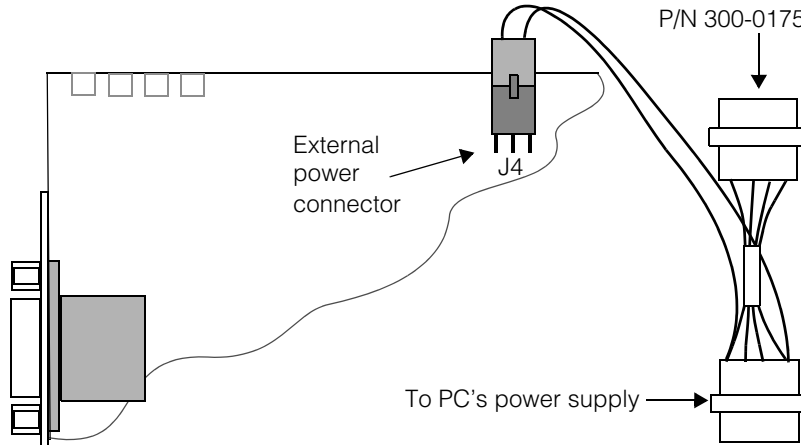

Figure 5. External power connection for the universal parallel I/O board

- Attach one end of the ribbon cable to the MVS-8120's 40-pin connector at position J2. The location of the parallel I/O connector on the the MVS-8120 is shown in Figure 2 on page 17.
- Attach the other end of the ribbon cable to the universal parallel I/O board's 40-pin connector at position J5.

## Installing the Standard Configuration UPIO Board

Set up the standard configuration of the universal parallel I/O board as shown in Figure 6.

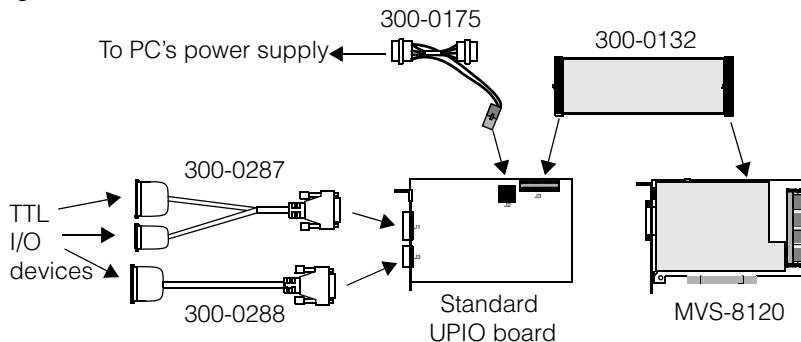

Figure 6. Setup of standard configuration UPIO board

If your universal parallel I/O board is the standard configuration, first follow the steps in the previous section, then continue with these steps:

1. Connect cable 300-0287 to the 26-pin connector on the parallel I/O board's back panel, and install the screw terminal connectors to both 16-pin and 10-pin branches of the cable.
2. Connect triggers, strobes, and other parallel I/O devices to the screw terminal connectors, using the pinouts in Table 14 on page 57 and Table 15 on page 58 as a guide.
3. If your application requires access to additional TTL output and TTL bidirectional lines, connect Cognex cable 300-0288 to the 15-pin auxiliary I/O port on the I/O board's back panel.

## Installing the Light Control UPIO Board

Set up the light control configuration of the universal parallel I/O board as shown in Figure 7.

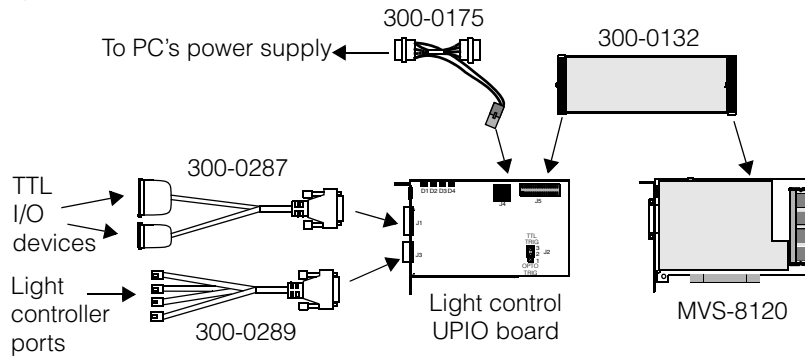

Figure 7. Setup of light control configuration UPIO board

If your universal parallel I/O board is the light control configuration, first follow the steps in *Installing the Universal PIO (UPIO) Board* on page 20, then continue with these steps:

1. Set jumper J2 for the desired trigger source, as described in Table 3.

<b>Jumper J2 position</b>	<b>Connect trigger devices to</b>
No Jumper or pins 2-3 covered (TTL TRIG position)	TTL inputs 1-4
Pins 1-2 covered (OPTO TRIG position)	Optically-isolated inputs 1-4

*Table 3. OPTO/TTL jumper settings*

See *OPTO/TTL Trigger Selection Jumper* on page 64 for more information on this jumper setting. See Figure 20 on page 50 for a drawing of the jumper location.

2. Connect cable 300-0287 to the 26-pin connector on the parallel I/O board's back panel, and install the screw terminal connectors to both 16-pin and 10-pin branches of the cable.
3. Connect triggers, strobes, and other parallel I/O devices to the screw terminal connectors, using the pinouts in Table 20 on page 65 and as a guide.
4. Connect cable 300-0289 to the 15-pin connector on the PIO board's back panel.
5. Connect the provided modular connectors to the RJ-11 plugs at the branch ends of cable 300-0289.
6. Connect North American standard four-conductor RJ-11 telephone wire between the modular connector of each branch, and the RJ-11 input port on a Cognex light controller assembly such as the acuLight or Ultralight.

**Note**

Always use the modular coupler (Amphenol part number 555050) provided with this cable. Other couplers may look the same but may not provide the same wiring pinout internally, and may reverse the bright and dark field light control lines.

## Installing the External UPIO Board

Set up the external configuration of the universal parallel I/O board as shown in Figure 8.

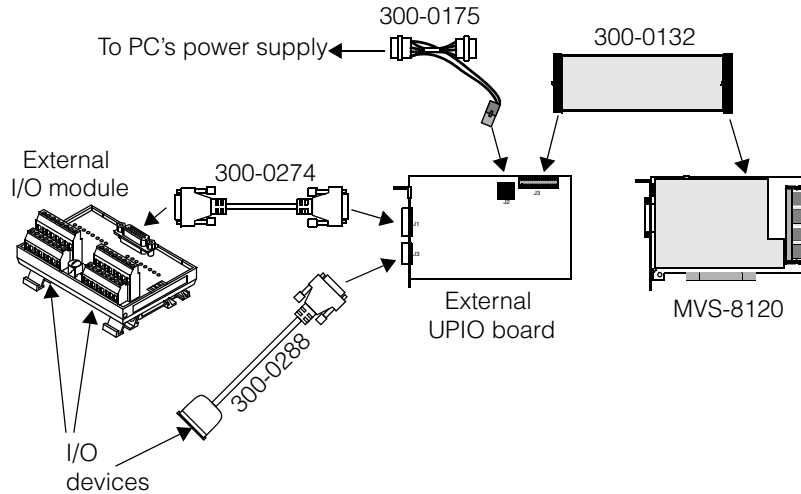

Figure 8. Setup of external configuration UPIO board

If your universal parallel I/O board is the external configuration, first follow the steps in *Installing the Universal PIO (UPIO) Board* on page 20, then continue with these steps:

1. Connect cable 300-0274 to the 26-pin connector on the parallel I/O board's back panel, and to the 26-pin connector on the external I/O module.
2. Connect triggers, strobes, and other parallel I/O devices to the input and output terminals on the external I/O module, using the pinouts in Table 27 on page 80 and Table 28 on page 81 as guides.
3. If your application requires access to additional TTL output and TTL bidirectional lines, connect Cognex cable 300-0288 to the 15-pin auxiliary I/O port on the I/O board's back panel. Attach a 16-pin screw terminal connector to the end of the cable.
4. Connect TTL I/O devices to the screw terminal connectors at the end of cable 300-0288.

## Installing One ISA PIO Board

If you are installing the single-board configuration of the ISA parallel I/O boards, use either the TTL board or the OPTO/TTL board. Both boards use the 12 inch (30.48 cm) ribbon cable supplied with parallel I/O boards, as shown in Figure 4 on page 20. The cable has a 40-pin connector on each end, and its connectors are keyed to ensure that they are inserted correctly.

Using Figure 9 on page 25 for reference, follow these steps to install a single ISA parallel I/O board:

1. Wear a grounded, static-dissipating wrist strap for ESD protection.
2. Turn off the PC and remove its cover.
3. Install the TTL or OPTO/TTL parallel I/O board in an ISA bus slot. Secure a mounting screw through the board's mounting bracket to the PC's back panel.
4. Attach one end of the ribbon cable to the MVS-8120's 40-pin connector at position J2. The location of the parallel I/O connector on the MVS-8120 is shown in Figure 2 on page 17.
5. Attach the other end of the ribbon cable to the parallel I/O board. For the TTL board, connect the cable to either of the board's two connectors.
6. Install the screw terminal connector to the parallel I/O board's faceplate.
7. Connect triggers, strobes, and other parallel I/O devices to the screw terminal connectors, using the pinouts in *ISA Parallel I/O Boards* on page 85 as a guide.

Figure 9 shows a TTL parallel I/O board installed with a MVS-8120.

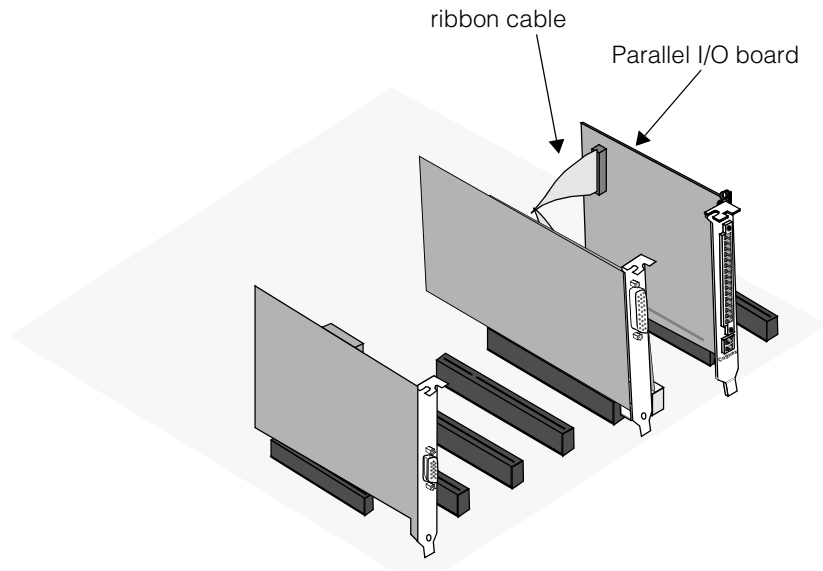

Figure 9. Single ISA parallel I/O board installed with MVS-8120

## Installing Two ISA PIO Boards

When you install two ISA I/O boards, install the TTL board closest to the MVS-8120 and install the OPTO/TTL board in the adjacent ISA slot. Cognex supplies a 4 inch (10.16 cm) ribbon cable (shown in Figure 10) to connect the two parallel I/O boards. The connectors are keyed to ensure that they are inserted correctly.

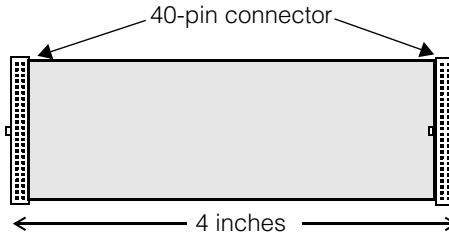

Figure 10. ISA parallel I/O board 4-inch ribbon cable (P/N 300-0133)

Using Figure 11 as a reference, follow these steps to install two ISA parallel I/O boards:

1. Wear a grounded, static-dissipating wrist strap for ESD protection.
2. Install the TTL parallel I/O board in an ISA bus slot near the MVS-8120. Secure a mounting screw through the board's mounting bracket to the PC's back panel.
3. Install the OPTO/TTL parallel I/O board in the ISA bus slot adjacent to the TTL board.
4. Attach the 12 inch ribbon cable to the MVS-8120's parallel I/O port at position J2 and to either of the two connectors on the TTL parallel I/O board.
5. Attach the 4 inch ribbon cable to the remaining connector on the TTL board and to the single connector on the OPTO/TTL board.
6. Install the screw terminal connectors to both parallel I/O board's faceplates.
7. Connect triggers, strobes, and other parallel I/O devices to the screw terminal connectors, using the pinouts in *ISA Parallel I/O Boards* on page 85 as a guide.

Figure 11 shows how the TTL board connects to the MVS-8120 and to the OPTO/TTL board. Note that the two parallel I/O boards function in exactly the same way when the ribbon cable connections on the TTL board are reversed.

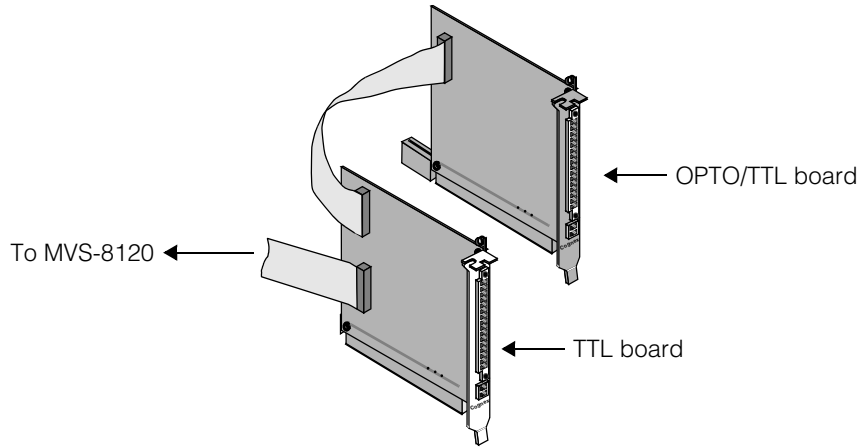

Figure 11. Double ISA parallel I/O board configuration

## Closing the System

To close the system, reinstall the enclosure cover. Make sure that internal cables are properly secured and will not be dislodged or interfere with proper air circulation for cooling when the enclosure cover is installed.

## Installing MVS-8120 External Hardware

Table 4 provides a summary of the steps to connect external components, such as cameras, triggers, and strobes, to your MVS-8120.

**Note** On host PCs that have per-slot power management, powering multiple cameras from the MVS-8120 frame grabber can result in the host PC disabling the frame grabber's PCI slot. To re-enable the frame grabber's PCI slot in this situation, you must supply power to the cameras from a source external to the frame grabber. For more on powering cameras from an external power source, see *Auxiliary Power Supply for Breakout Box* on page 113 and *Auxiliary Power Supply for Breakout Cable* on page 115.

Model	Component	Installation and Further Instructions
MVS-8120/CVM1	Any monochrome analog camera	Attach either the camera breakout box or camera breakout cable to the MVS-8120.
MVS-8120/CVM1	Camera breakout box	Attach the camera breakout box, P/N 800-5637-1, to the DB-26F connector on the MVS-8120. Camera port numbers are silkscreened on the breakout box. See <i>Attaching Cameras to the CVM Breakout Box</i> on page 112.
MVS-8120/CVM1	Auxiliary camera power supply for breakout box	Attach to the camera breakout box to provide additional power in cases where external cameras require more than 750 mA of +12 V power. See <i>Auxiliary Power Supply for Breakout Box</i> on page 113.
MVS-8120/CVM1	Camera breakout cable	Attach the camera breakout cable, P/N 300-0232 or 300-0230, to the DB-26F connector on the MVS-8120. See <i>Attaching the Camera Breakout Cable</i> on page 114.
MVS-8120/CVM1	Auxiliary camera power supply for breakout cable	Attach to camera breakout cable 300-0230 to provide additional power in cases where external cameras require more than 750 mA of +12 V power. See <i>Auxiliary Power Supply for Breakout Cable</i> on page 115.

Table 4. Connecting cameras to the MVS-8120

Model	Component	Installation and Further Instructions
MVS-8120/CVM1	Any supported analog camera	Identify the Cognex camera cable to use in the Supported Cameras table for your Cognex software release. Connect the camera cable between the camera and the camera breakout box or breakout cable.
MVS-8120/CVM4	Cognex CVC-1000 high-speed camera	Connect a CVC-1000 breakout cable to the MVS-8120. Use either the four-camera breakout cable, P/N 300-0220, or the one-camera breakout cable, P/N 300-0224. Connect CVC-1000 cameras to either breakout cable using the CVC-1000 camera cable, P/N 300-0223. See <i>Connecting Cognex CVC-1000 Cameras</i> on page 123 for important connection information and usage notes.
MVS-8120/CVM6 MVS-8120/CVM9	Hitachi KP-F100 or KP-F100A digital camera	See <i>Connecting Hitachi KP-F100 Digital Cameras</i> on page 127 for important connection information and usage notes.
MVS-8120/CVM9	Hitachi KP-F100B digital camera	See <i>Connecting Hitachi KP-F100 Digital Cameras</i> on page 127 for important connection information and usage notes.
MVS-8120/CVM6 MVS-8120/CVM9	Basler A101/A101P/A113P digital camera	See <i>Configuring Basler A101/A101P/A113P Cameras</i> on page 119 for important setup information.
MVS-8120/CVM6 MVS-8120/CVM9	Any supported analog camera	Identify the Cognex camera cable to use in Supported Cameras table for your Cognex software release. Connect the camera cable between the camera and the camera breakout box or breakout cable.
MVS-8120/CVM11	Dalsa Spyder SP-13 or SP-14 camera	See <i>Connecting Dalsa Spyder Line Scan Cameras</i> on page 127 for important connection information and usage notes.

Table 4. Connecting cameras to the MVS-8120

Model	Component	Installation and Further Instructions
MVS-8120/CVM11	Basler L103-2K camera	See <i>Configuring Basler L103-2k Cameras</i> on page 121 for important setup information.
All	Parallel interface devices	Install one of the parallel I/O board options. Attach wiring and secure with clamping screws to the connector provided by your parallel I/O board option. See <i>Cognex Parallel I/O Board Options</i> on page 44.

Table 4. Connecting cameras to the MVS-8120

# Cognex MVS-8120 Hardware Description

# 2

- This chapter describes the Cognex MVS-8120 frame grabber hardware.

This chapter contains the following sections:

- *MVS-8120 Components* on page 32 describes the components that make up the MVS-8120.
- *Mechanical Specifications* on page 34 provides a physical description of the MVS-8120, including information about mechanical layout, environmental requirements, and safety standards.
- *Electrical Specifications* on page 36 describes the electrical interface to the MVS-8120, including power requirements, connector pinouts, and circuit descriptions.

# MVS-8120 Components

This section describes the MVS-8120 frame grabber and its components.

## PCI Bus Interface

The PCI bus interface of revision C or later of the MVS-8120 is a universal voltage 32-bit interface that conforms to the PCI 2.1 standard. Revisions A and B of the MVS-8120 use a 5-volt only 32-bit PCI interface.

## Input Video System

Input video on the MVS-8120 is provided by a Cognex Video Module (CVM). Different models of the MVS-8120 have different CVMs, to meet different customer requirements. CVMs are *not* customer-upgradeable and are factory-installed purchase options only.

The input video capabilities of available CVMs are discussed in *Cognex Video Modules and Cameras* on page 89.

## Parallel I/O

The MVS-8120 frame grabber communicates with devices such as strobes, triggers, sensors, and programmable controllers over parallel signal interface lines. An internal connector on the frame grabber provides the following signals:

- Eight transistor-to-transistor logic (TTL) inputs
- Eight TTL outputs
- Eight bidirectional TTL lines
- Four opto-isolated outputs

Parallel I/O options for the MVS-8120 frame grabber are described in *Cognex Parallel I/O Board Options* on page 44.

## Video Output

MVS-8120 image output is passed through the PCI bus to an AGP or PCI-based video display adapter on the same bus, under the control of the host PC's operating system.

The MVS-8120 frame grabber can send images at a real-time acquisition rate of at least 24 frames/second through an unsaturated PCI bus, assuming that the installed camera can acquire images at that rate. With some large format cameras, live display may be limited to much lower frame rates.

To display images from an MVS-8120, the host PC's display adapter must connect through the PCI or AGP bus (that is, it cannot be an ISA-based display adapter). The MVS-8120 will work with most PCI- or AGP-based video display adapters, but can achieve maximum performance only with video adapters that meet certain requirements, as discussed in *Requirements for Maximum Frame Rate* on page 14. Contact your Cognex sales engineer for information about recommended video adapters.

# Mechanical Specifications

This section describes the mechanical layout, environmental requirements, and standards for the MVS-8120 frame grabber.

## Layout

The MVS-8120 frame grabber is a short length PCI card, measuring 6.875 x 4.2 inches (175 x 107 mm). Figure 12 shows the dimensions and user-accessible components on the MVS-8120.

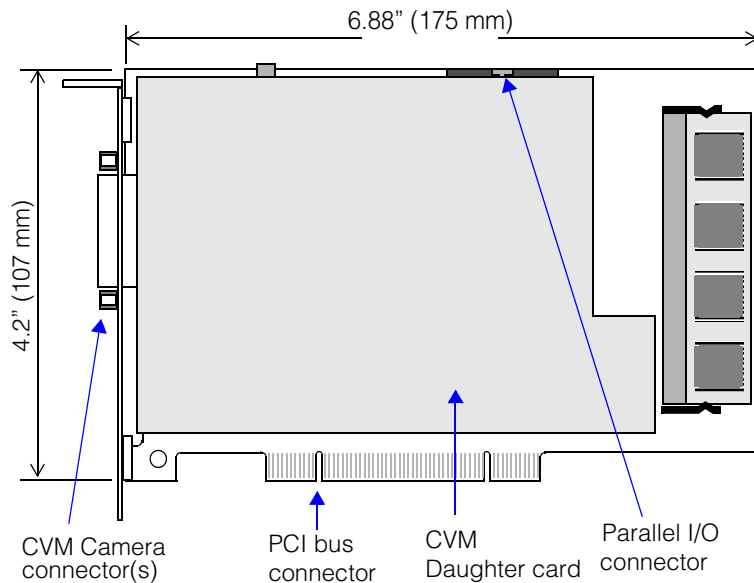

Figure 12. MVS-8120 frame grabber layout

A Cognex Video Module (CVM) daughter card is factory-installed on the MVS-8120 board. The configuration and number of connectors on the CVM depends upon the CVM installed.

## Environmental Requirements

Table 5 lists the environmental requirements for the MVS-8120 frame grabber. These specifications are for the environment inside the PC where the MVS-8120 is installed.

	Operating Conditions	Storage Conditions
<b>Temperature</b>	0° to 50° C	-40° to 65° C
<b>Humidity</b> (non-condensing)	10% to 90%	10% to 90%

Table 5. Environmental requirements for the MVS-8120

## Shipping

All Cognex MVS-8120 frame grabbers are shipped in protective packaging and antistatic bags. Save all packing materials in case you need to ship the MVS-8120.

## Standards

The MVS-8120 is designed and manufactured to meet the following worldwide standards for safety, electromagnetic compatibility, and electrostatic sensitivity when installed in a compliant PC enclosure:

### European Community

- Safety: EN 60 950, EN 60 204-1
- Electromagnetic emissions: EN 55 022 Class A
- Electromagnetic compatibility: EN 50 082-1

### United States

- Underwriters Laboratories
  - Safety: UL-1950
  - Flammability: UL 94V-0
- Code of Federal Regulations Part 15: Federal Communications Commission Class A radio frequency emissions standard

# Electrical Specifications

This section describes the electrical interface to the MVS-8120, and provides information for connection and control of external hardware.

## MVS-8120 Power Requirements

Input power to the MVS-8120 frame grabber is provided through the PCI bus connector. Table 6 lists the input voltage and tolerance, and maximum PC power consumption required by an installed system.

Voltage	Maximum MVS-8120 draw	Allowable draw by cameras	Total current
+5 V $\pm$ 3%	5.0 A		5.0 A
+12 V $\pm$ 5%	500 mA	750 mA	1250 mA
-12 V $\pm$ 5%	100 mA		100 mA

Table 6. MVS-8120 frame grabber power requirements

When you use cameras that draw power from the video camera port, the +12 V power use increases accordingly. The combined total draw of all cameras may not exceed 750 mA, limited by PolySwitch circuit protection on the MVS-8120. A typical monochrome camera uses from 150 to 250 mA but some cameras draw much more.

An external power adapter can be used to provide supplemental +12 V power to cameras attached to MVS-8120 systems equipped with a camera breakout box or breakout cable. This avoids the use of system power for that purpose. See *Auxiliary Power Supply for Breakout Box* on page 113 and *Auxiliary Power Supply for Breakout Cable* on page 115.

**Note** The PCI bus connector on the MVS-8120 is keyed to allow placement in either a 5 V or a 3.3 V PCI slot. However, only MVS-8120 boards with revision C or later of the circuit board are qualified to use in 3.3 V PCI slots.

MVS-8120 boards with revision A or B circuit boards are qualified for use only in 5 Volt PCI slots, which are by far the most common PCI slot type found.

See the installation instructions on page 18 for more information.

## Parallel I/O Port

The MVS-8120 has 32 I/O lines configured as eight TTL input lines, eight TTL output lines, eight bidirectional general I/O TTL lines, and four pairs of opto-isolated output lines. All 32 lines are brought out into a 40-pin parallel I/O connector.

Cognex provides several parallel I/O board options that carry some or all of the MVS-8120's parallel I/O signals, along with two digital grounds, to the back of the PC. Connect triggers, strobes, and other parallel I/O devices to the connectors on the parallel I/O boards, not directly to the 40-pin connector on the MVS-8120. The parallel I/O board options are described in *Cognex Parallel I/O Board Options* on page 44. See *Installing Parallel I/O (PIO) Boards* on page 19 for installation instructions.

## Parallel I/O Port Pin Numbering

The MVS-8120 parallel I/O port connector is a 40-pin shrouded double-row, high-density male IDC header. Figure 13 shows the parallel I/O connector pin numbering. Under normal circumstances, you connect parallel I/O devices to one of the parallel I/O boards, and never directly to the port on the MVS-8120.

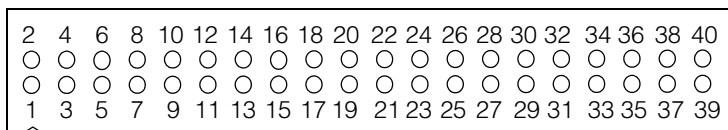

Figure 13. Parallel I/O connector pin numbering

## Parallel I/O Port Pinout

Table 7 shows the pinout for the MVS-8120 parallel I/O port.

Pin	Signal	Pin	Signal
1	TTL_IN_1	2	TTL_IN_2
3	TTL_IN_3	4	TTL_IN_4
5	TTL_IN_5 (Trigger 1)	6	TTL_IN_6 (Trigger 2)
7	TTL_IN_7 (Trigger 3)	8	TTL_IN_8 (Trigger 4)
9	Ground	10	No connection
11	Ground	12	TTL_OUT_1

Table 7. MVS-8120 pinout for parallel I/O port

Pin	Signal	Pin	Signal
13	TTL_OUT_2	14	TTL_OUT_3
15	TTL_OUT_4	16	TTL_OUT_5
17	TTL_OUT_6	18	TTL_OUT_7
19	TTL_OUT_8	20	Ground
21	TTL_BI_8	22	TTL_BI_7
23	TTL_BI_6	24	TTL_BI_5
25	TTL_BI_4	26	TTL_BI_3
27	TTL_BI_2	28	TTL_BI_1
29	Ground	30	OPTO_OUT1 + (Strobe 1)
31	OPTO_OUT1 – (Strobe 1)	32	OPTO_OUT2 + (Strobe 2)
33	OPTO_OUT2 – (Strobe 2)	34	Ground
35	Ground	36	OPTO_OUT3+ (Strobe 3)
37	OPTO_OUT3 – (Strobe 3)	38	OPTO_OUT4+ (Strobe 4)
39	OPTO_OUT4 – (Strobe 4)	40	Ground

Table 7. MVS-8120 pinout for parallel I/O port

## Parallel Input (Trigger) Lines

Figure 14 shows the MVS-8120 TTL parallel input (TTL\_IN) circuit.

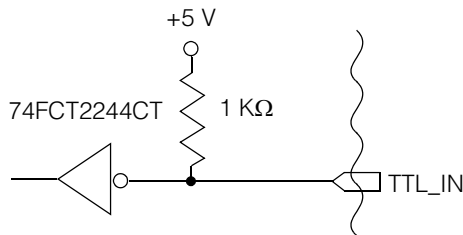

Figure 14. MVS-8120 parallel input circuit

To guarantee a valid logic low input, a logic circuit driving a TTL input directly to the frame grabber must be capable of sinking a minimum of 14 mA at 0.5 V. Since each TTL input is pulled up by a 1000  $\Omega$  resistor, you can use an open collector circuit to drive the inputs.

## Parallel Output Lines

Figure 15 shows the MVS-8120 TTL parallel output (TTL\_OUT) circuit.

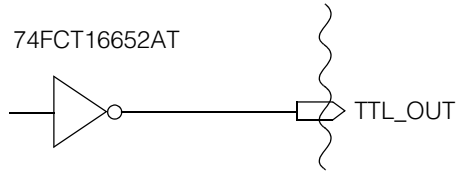

Figure 15. MVS-8120 parallel output circuit

## Parallel Bidirectional Lines

Figure 16 shows the bidirectional general I/O (TTL\_BI) parallel circuit.

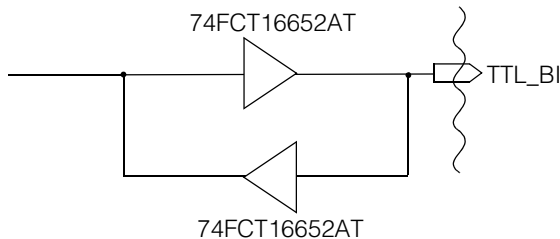

Figure 16. MVS-8120 general I/O parallel circuit

The eight bidirectional general I/O lines are electronically equivalent to Figure 14 when being used for input and to Figure 15 when being used for output.

## Opto-Isolated Output (Strobe) Lines

Figure 17 shows the circuit for the opto-isolated (OPTO\_OUT) outputs.

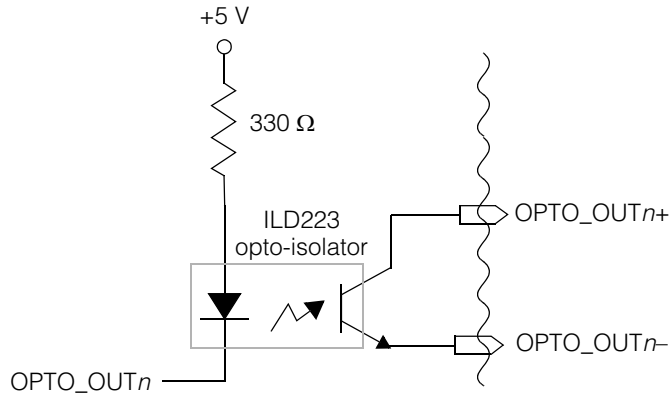

Figure 17. Opto-isolated output circuit

## Using Optically Isolated Outputs

You can wire the optically isolated outputs in one of two ways: *voltage source output wiring* or *contact closure output wiring*.

Figure 18 shows an example of the voltage source output wiring configuration. You connect an external power supply (for example, 24 VDC) to OPTO\_OUT+. Connect OPTO\_OUT- to external equipment. The external equipment should present enough impedance so that no more than 125 mA flows through the circuit.

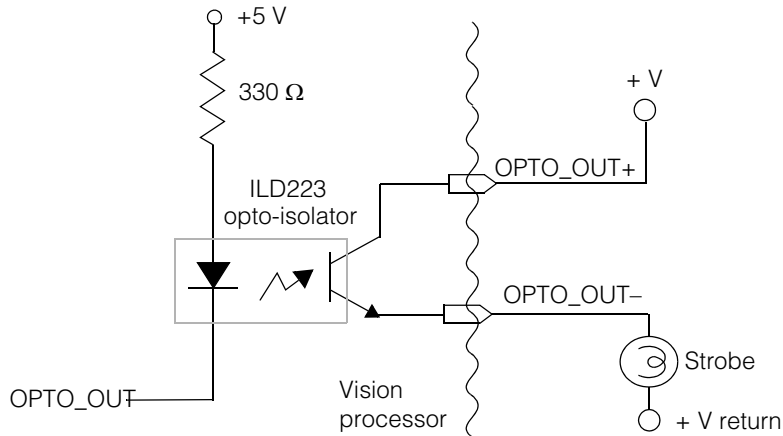

Figure 18. Optically isolated output: voltage source wiring

Figure 19 shows an example using the contact closure output wiring configuration. Output is taken directly from OPTO\_OUT+ and OPTO\_OUT-. This output functions as a contact closure switch. Ensure that current (125 mA) and voltage (30 V) limits are not exceeded.

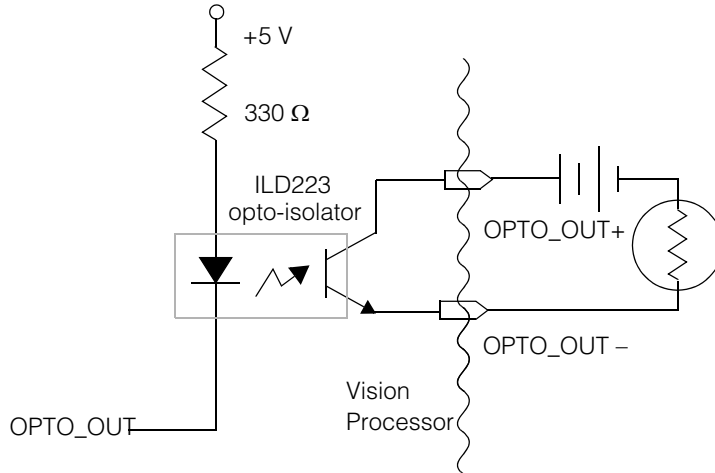

Figure 19. Optically isolated output: contact closure wiring

## Hardware Triggering of Acquisitions and Strobes

The MVS-8120 supports hardware triggering of image acquisitions and hardware triggering of strobe firing. A signal of 1  $\mu\text{s}$  (or longer) on a trigger line triggers an image acquisition if you are using a CCIR camera; a 1.2  $\mu\text{s}$  signal or longer is required for an EIA RS-170 camera. If you configure both a trigger line and a strobe pair for a given camera, the image acquisition and the firing of the strobe occur simultaneously.

For the MVS-8120, the TTL\_IN\_5 through TTL\_IN\_8 signal lines support the hardware triggering of image acquisitions. The OPTO\_OUT1 through OPTO\_OUT4 pairs of lines support the firing of a strobe. These signals are typically transferred through an attached parallel I/O board.

To make use of the video trigger and strobe features, you must install a Cognex parallel I/O board or a board of your own construction that makes these signals available to your application.

### Note

The use of your own parallel I/O boards has warranty implications. See section 9, Warranty, of the Cognex Corporation Standard Terms and Conditions of Sale, which is attached to your Cognex sales order.

## Available Acquisition Channels

Independent of the number of pins available on the parallel I/O connector, the number of hardware trigger and strobe lines that a frame grabber actually supports is equal to the number of its acquisition channels. Thus, a frame grabber with three acquisition channels supports only three trigger lines and three strobe pairs, despite having four theoretical lines and pairs available.

The number of acquisition channels provided is determined by the Cognex Video Module (CVM) in use, as described in *Video Input Capabilities* on page 90. The correspondence between trigger line numbers and camera port numbers depends on the CVM in use.

For most CVMs, the correspondence is one-to-one, where trigger line 1 triggers an acquisition on camera port 1, which fires a strobe on Strobe pair 1, and so on. However, certain CVMs have a different correspondence. For the correspondence between trigger/strobe line numbers and camera port numbers, consult the *CVM Line Numbering* section of each CVM's description in *CVM Descriptions* beginning on page 93.

This chapter describes the Cognex parallel I/O boards that are used to carry the MVS-8120's parallel I/O signal lines to the PC's back panel.

This chapter contains the following sections:

- *Cognex Parallel I/O Board Options* on page 44 distinguishes the two types of parallel I/O boards available.
- *Universal Parallel I/O Board* on page 49 describes the non-bus connected parallel I/O board in its three configurations.
- *External I/O Module* on page 76 describes the external I/O module used with the universal parallel I/O board.
- *ISA Parallel I/O Boards* on page 85 describes the ISA connected parallel I/O boards in their TTL and OPTO/TTL configurations.

# Cognex Parallel I/O Board Options

Parallel I/O boards provide a connection point for I/O devices such as triggers, strobes, part rejection switches, status LEDs, and other parallel I/O devices. The frame grabber's 40-pin parallel I/O port connects to an equivalent 40-pin port on one of the parallel I/O boards, thus extending the frame grabber's I/O lines out to the back panel of the PC or to an external I/O module.

Cognex provides two classes of parallel I/O (PIO) boards for use with the MVS-8120:

- The universal parallel I/O (UPIO) boards, which take up a slot position but do not connect to the host PC's bus. The universal boards are available in standard, light control, and external configurations.
- The ISA parallel I/O boards, which plug into the host PC's ISA bus. There are two ISA boards, the TTL board and the OPTO/TTL board.

Each class of parallel I/O board has configuration options, resulting in several parallel I/O options overall. Table 8 summarizes the differences between the options.

Board Description	Cognex P/N	Connection	Device Connections	Signals
ISA PIO board: OPTO/TTL	801-0002-1	8-bit portion of ISA slot	12	<ul style="list-style-type: none"> <li>• 4 TTL IN (for hardware triggers)</li> <li>• 4 TTL bidirectional</li> <li>• 4 OPTO OUT pairs (for strobes)</li> </ul>
ISA PIO board: TTL	801-0003-1	8-bit portion of ISA slot	16	<ul style="list-style-type: none"> <li>• 4 TTL IN</li> <li>• 8 TTL OUT</li> <li>• 4 TTL bidirectional</li> </ul>
Universal PIO board: Standard configuration	800-5726-1	No bus connection: use in any slot position	28	<ul style="list-style-type: none"> <li>• 8 TTL IN (4 for hardware triggers)</li> <li>• 4 OPTO OUT pairs (for strobes)</li> <li>• 8 TTL OUT</li> <li>• 8 TTL bidirectional</li> </ul>

Table 8. Comparison of parallel I/O options

Board Description	Cognex P/N	Connection	Device Connections	Signals
Universal PIO board: Light control configuration	800-5726-2	No bus connection: use in any slot position	20	<ul style="list-style-type: none"> <li>• 4 TTL IN (selectable as triggers)</li> <li>• 4 OPTO IN pairs (selectable as triggers)</li> <li>• 4 OPTO OUT pairs (for strobes)</li> <li>• 4 TTL bidirectional</li> <li>• 4 RJ-11 dynamic light control connectors</li> </ul>
Universal PIO board: External configuration	800-5726-3	No bus connection: use in any slot position. Connects to the external I/O module.	28	<p>When used with external I/O module:</p> <ul style="list-style-type: none"> <li>• 8 OPTO IN pairs (4 for hardware triggers)</li> <li>• 8 OPTO OUT pairs (4 for strobes)</li> <li>• 8 TTL OUT</li> <li>• 4 TTL bidirectional</li> </ul>

Table 8. Comparison of parallel I/O options

Note the following points about the parallel I/O options:

- Cognex continues to support the ISA parallel I/O boards so that you can continue to use your existing hardware. For new applications, use the universal parallel I/O board, which supports all of the signals of the two ISA boards combined.
- With the ISA boards, you can use either the OPTO/TTL board, the TTL board, or both boards, as your application requires. With both boards, you get 28 device connections.
- With the universal board options, you can connect only one configuration per vision board.
- If you use the external configuration of the universal I/O board, you must also use the Cognex external I/O module. The external configuration board cannot be used by itself, or only with a cable.
- With the universal board, you can make use of additional lines by using a second output cable, as described in *Auxiliary (HD-15F) Parallel I/O Port* on page 54.

## Check Software Release Notes

This chapter describes the parallel I/O (PIO) options supported by your Cognex vision system. However, not all Cognex software releases support all configurations and options of the PIO boards. Check your software package's release notes for any notes on configurations not supported by that software release.

## Determining Line Numbering

To successfully control a parallel I/O device with Cognex software, you must have the following items of information:

- You must know which physical pin on your PIO cable (or external I/O module) is connected to each PIO signal line, such as TTL\_OUT\_1.

That class of information is found in the pinout tables of this chapter.

- Certain signal lines have predetermined functions in hardware as trigger or strobe lines, associated with a camera port. You must know which camera port is associated with each trigger and strobe line.

That information is discussed in *Associate Trigger and Strobe with Camera Port* on page 47.

- You must know the software syntax that associates a software command with a signal line such as TTL\_OUT\_1.

That information is discussed in *Software Line Numbering* on page 48.

The signal line names are standardized throughout Cognex documentation in the forms shown in Table 9, where  $n$  is an integer.

Signal Name	Description
TTL_IN_ $n$	TTL input line
TTL_OUT_ $n$	TTL output line
TTL_BI_ $n$	Bidirectional TTL line, can be used either for input or output
OPTO_OUT $n$ +, OPTO_OUT $n$ -	Optically isolated output pair, with positive and negative connections

Table 9. Standard PIO signal names in Cognex documentation

Signal Name	Description
OPTO_INn+, OPTO_INn-	Optically isolated input pair, with positive and negative connections
TTL GND	Common ground line for TTL lines

Table 9. Standard PIO signal names in Cognex documentation

The standard signal names serve as bridges between Cognex hardware and software documentation, as follows:

- Look in Cognex software documentation to associate software commands with signal names.
- Look in Cognex hardware documentation to associate signal names with physical pin locations.

## Associate Trigger and Strobe with Camera Port

The origin of the parallel I/O signal lines is the MVS-8120 vision board; the parallel I/O board simply carries those signal lines to the host PC's back panel. It is the CVM module on the vision board that determines the correspondence between parallel I/O signal lines, such as TTL\_IN\_5, and the line number for camera, trigger, and strobe connections. This correspondence is documented in the *CVM Line Numbering* section for each CVM in *CVM Descriptions on page 93*.

- For CVM1, see *CVM1 Line Numbering on page 94*.
- For CVM4, see *CVM4 Line Numbering on page 97*.
- For CVM6/9, see *CVM 6 and CVM9 Line Numbering on page 100*.
- For CVM11, see *CVM11 Line Numbering on page 104*.

Trigger and strobe lines can be thought of as having logical position numbers from 1 to 4. CVMs associate physical camera ports with logical position numbers. For CVM1 and CVM4, the association is one-to-one. That is, camera port 1 is associated with trigger line 1 and strobe pair 1.

For some CVMs, including CVM6, CVM9, and CVM11, the camera port association with logical trigger and strobe position numbers does not start with one. For example, on CVM6 and CVM9, there are three camera ports associated with logical position numbers 2, 3, and 4. On CVM11, there are two camera ports associated with positions 3 and 4.

## Software Line Numbering

Cognex software products based on the Cognex Vision Library (CVL) use a C++ class to describe hardware capabilities. For example, for the MVS-8120 hardware, CVL provides the **cc8120** class. Refer to the documentation for that class in the *CVL Class Reference* to learn the correspondence between software line numbers and standard signal names, such as TTL\_OUT\_1. Then use this chapter to associate the signal name with physical pin numbers.

## Using Bidirectional Lines as Outputs

When using a bidirectional TTL line as an output line on any configuration of the universal parallel I/O (UPIO) board, the line may transition from high to low when first initialized by the application software. The following work arounds are available for this behavior:

For the standard and light control configurations only

- Add an external 470 Ohm pull-down resistor to each bidirectional line you configure as an output line.

For all UPIO configurations

- Set external devices connected to the bidirectional lines used as outputs to ignore any transitions until the lines have been fully configured by the application software.

## Universal Parallel I/O Board

The universal parallel I/O (UPIO) board is available in the configurations described in Table 8 on page 44. In the standard and light control configurations, you connect devices to cables that are connected to the back panel of the I/O board. In the external configuration, a cable connects the I/O board's back panel to an external I/O module, to which you connect devices. The external I/O module is described in *External I/O Module* on page 76.

Table 10 shows the breakout cables and part numbers for the universal parallel I/O boards.

Parallel I/O Board Configuration	Connector on Parallel I/O Board	Cognex Cable Number	Connectors
Standard Configuration	Main (26-pin)	300-0287	One 16-position screw terminal One 10-position screw terminal
	Aux (15-pin)	300-0288	One 16-position screw terminal
Light Control Configuration	Main (26-pin)	300-0287	One 16-position screw terminal One 10-position screw terminal
	Lights Port (15-pin)	300-0289	Four RJ-11 modular connectors
External Configuration	Main (26-pin)	300-0274	One 26-pin connector passed through to the external I/O module
	Aux (15-pin)	300-0288	One 16-position screw terminal

Table 10. Parallel I/O Board breakout cables

The I/O capabilities of the universal I/O board options are described in Table 8 on page 44.

## Layout

The universal parallel I/O (UPIO) board is a half-length card that measures 5.3 x 4.2 inches (135 x 107 mm). The board occupies a slot position but does not plug into a bus connector. It can be installed into either an ISA, PCI, or AGP slot position of the host PC. Figure 20 shows the layout of the board.

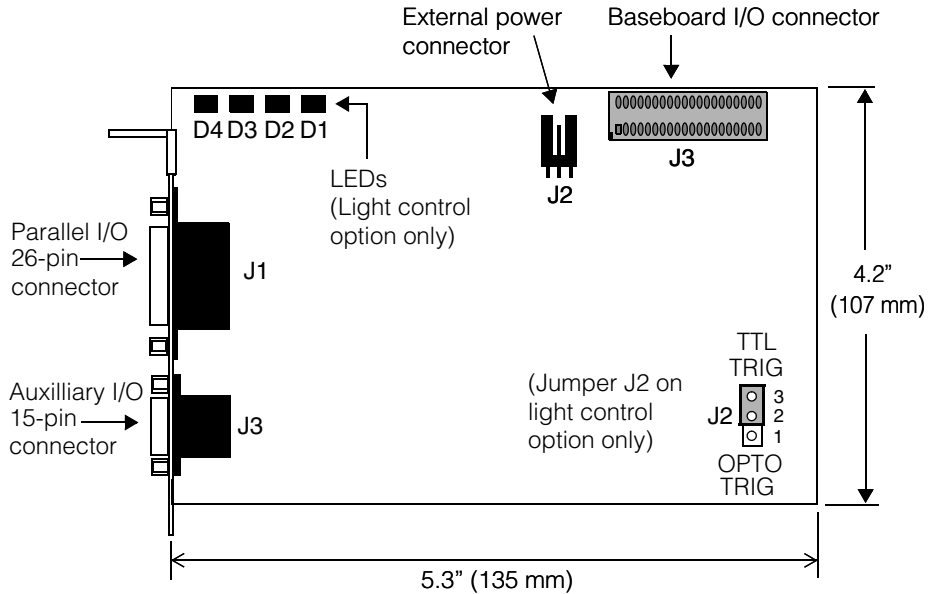

Figure 20. Layout of universal parallel I/O board

The board has the following user-accessible components:

- A 26-pin parallel I/O connector, J1, carries parallel I/O signals.
- A 15-pin auxiliary I/O connector, J3, carries additional parallel I/O or light control signals.
- An external power connector, J2, provides a connection for +12 V external power as well as protection against electrostatic discharge and over-voltage situations.
- A 40-pin baseboard parallel I/O connector, J3, provides a connection to the Cognex vision board.
- On the light control configuration only, jumper J2 to switch between TTL and OPTO inputs for use as hardware triggers.

## Board Placement Considerations

The universal parallel I/O boards are in PCI form factor despite not connecting to the PCI bus. That is, the board is attached to the left side of the back panel bracket, as you face the outside of the back panel faceplate. (By contrast, ISA form factor boards attach to the right side of the faceplate.) The PCI form factor of these boards does not affect placement in a PC with all PCI or AGP slots, but might affect placement in a PC with mixed PCI and ISA slots. If the board adjacent to the parallel I/O board is in an ISA slot, make sure there is sufficient clearance between boards.

The universal parallel I/O board extends about half an inch above the top of the back panel faceplate, and needs space above the board to connect the ribbon cable to your vision board. This does not affect placement in the majority of desktop or tower case PCs. However, the extra height might prevent the board from fitting into a low profile PC, especially one whose PCI slots extend up from the motherboard on a riser card. Test the placement of the UPIO board in any low profile PC you may be considering as host.

## Environmental Requirements

The environmental requirements for the universal parallel I/O board are the same as for the MVS-8120, as described in *Environmental Requirements* on page 35.

## Power Requirements

The parallel I/O board draws power through an external power supply connector. It does not draw power through a host PC bus slot.

The external power supply connector, J2, provides external +12 V power from the host PC through the power adapter cable, Cognex P/N 300-0175. Table 11 shows the pinout of the external power supply connector.

Pin	Signal
1	Ground
2	No connection
3	+12 V

Table 11. Pinout of J2 power connector on universal parallel I/O board

The connector is keyed so that the cable can only be inserted the correct way. The amount of external power that can be drawn is determined by the host PC and is a maximum of 0.5 A.

## Baseboard Parallel I/O Connector

The 40-pin baseboard parallel I/O input connector, J3, accepts PIO signals from the associated Cognex vision board. A ribbon cable connects the vision board's 40-pin PIO connector with this connector on the UPIO board.

The baseboard parallel I/O connector is a 40-pin, shrouded, double-row, high-density male header. Figure 21 shows the pin numbering of the connector.

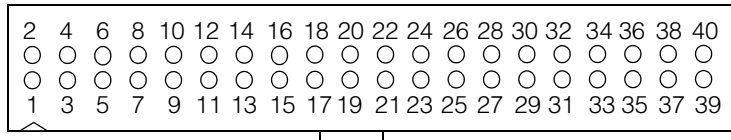

Figure 21. Pin numbering of baseboard 40-pin I/O connector

Since they are connected by a one-to-one ribbon cable, the pinout of the parallel I/O board's 40-pin input connector is necessarily the same as the pinout of the MVS-8120's 40-pin PIO output connector, as shown in Table 7 on page 37.

See *Installing Parallel I/O (PIO) Boards* on page 19 for instructions on connecting the baseboard I/O connector to your vision board's 40-pin connector.

## Main (DB-26F) Parallel I/O Port

The external parallel I/O port, J1, is a 26-pin high density DB-26F female connector located on the back panel of the universal I/O board. Figure 22 shows the pin numbering of the port.

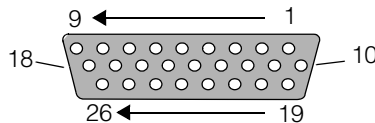

Figure 22. Pin numbering of 26-pin external I/O port

All parallel I/O lines are protected against overvoltage and electrostatic discharge.

To connect I/O devices, you must connect a Cognex cable to this port, or a cable of your own construction. The Cognex cables to use on this port are shown in Table 12; they are described in detail in the next section, *Cable 300-0287* on page 53, and in *Cable 300-0274* on page 54.

Universal I/O Board Configuration	Cognex Cable P/N	Connects to	Then to
Standard	300-0287	I/O devices	
Light control	300-0287	I/O devices	
External	300-0274	External I/O module	I/O devices

Table 12. Cables to connect to 26-pin external parallel I/O port

**Note** Cognex does not support the connection of parallel I/O devices directly to the main parallel I/O port. Use one of the connection options shown in Table 12, or a cable you make.

If you will construct your own parallel I/O cables, you will need the pinout of the external 26-pin I/O port. The configuration of the UPIO board you are using determines the pinout of this port. For pinout information, see *Standard Configuration: Cable Pinouts* on page 57 and *Light Control Configuration: Port Pinouts* on page 68.

## Cable 300-0287

Cognex cable 300-0287 is used with the standard and light control configurations of the UPIO board. It uses a 26-pin high density male connector broken out to one 16-position and one 10-position female plug. Screw terminal connectors are attached to each plug. Figure 23 depicts the cable.

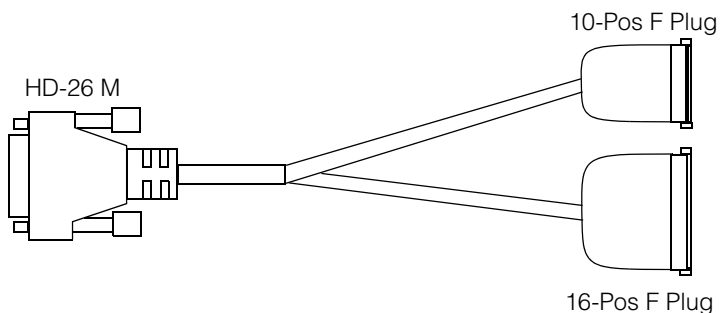

Figure 23. Cable 300-0287

When using cable 300-0287, connect wires from your parallel I/O devices to the screw terminal connectors at the branch ends of this cable. The configuration of the UPIO board you are using determines the pinout of the screw terminal connectors. See *Standard Configuration: Cable Pinouts* on page 57 and *Light Control Configuration: Cable Pinouts* on page 64 for pinout information.

## Cable 300-0274

Cognex cable 300-0274 is used with the external configuration of the UPIO board. It is a straight-through cable that connects the UPIO board to the external I/O module. Both ends of the cable have a 26-pin high density male connector. The pins are connected one-to-one throughout the cable; that is, pin 1 on the left hand connector is tied to pin 1 on the right-hand connector; pin 2 connects to pin 2, and so on for all 26 pins. Figure 24 depicts the cable.

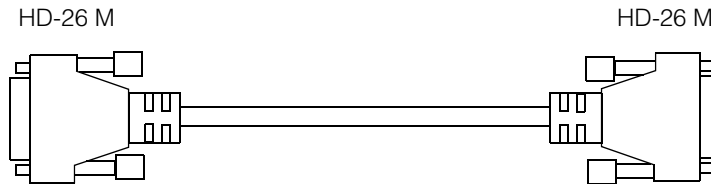

Figure 24. Cable 300-0274

When using cable 300-0274, connect your parallel I/O devices to the external I/O module, as described in *External I/O Module* on page 76.

## Auxiliary (HD-15F) Parallel I/O Port

The external auxiliary I/O port, J3, is a 15-pin high density female connector located on the back panel of the universal I/O board. The labeling for this port reads “Aux I/O - Light Port” to describe the use of this port when used by several Cognex product lines.

Figure 25 shows the pin numbering of the external auxiliary I/O port.

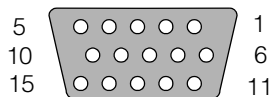

Figure 25. Pin numbering of auxiliary I/O port

**Note**

The external auxiliary I/O port resembles the industry-standard VGA port, but is wired very differently. Do not connect a monitor to this port or you may damage your monitor or the PIO board.

To connect I/O devices to the auxiliary I/O port, you must connect a Cognex cable to this port, or a cable of your own construction. The Cognex cables to use on this port are shown in Table 13. Each cable is described in detail in *Cable 300-0288* on page 55 and *Cable 300-0289* on page 56.

UPIO board configuration	Cognex cable P/N
Standard	300-0288
Light control	300-0289
External	300-0288

Table 13. Cables to connect to 15-pin auxiliary I/O port

**Note** Cognex does not support the connection of parallel I/O devices directly to the auxiliary I/O port. Connect devices only to the screw terminal end of cable 300-0288 or to a cable you make.

If you will construct your own parallel I/O cable, you will need the pinout of the external 15-pin I/O port. The configuration of the UPIO board you are using determines the pinout of this port. See *Standard Configuration: Cable Pinouts* on page 57 and *External Configuration: Cable Pinouts* on page 71 for pinout information. (This port's pinout for the external UPIO configuration is the same as for the standard configuration.)

## Cable 300-0288

Use cable 300-0288 with the standard and external configuration of the UPIO board. The cable uses a 15-pin high density male connector broken out to one 16-position female plug. A screw terminal connector is attached to the plug.

Attach wires from your parallel I/O devices to the screw terminal connector. Figure 26 depicts the cable.

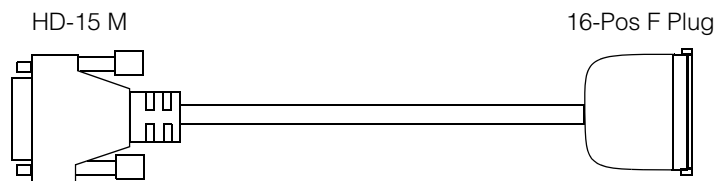

Figure 26. Cable 300-0288

When using cable 300-0288, connect wires from your parallel I/O devices to the screw terminal connectors at the branch end of this cable. The configuration of the UPIO board you are using determines the pinout of the screw terminal connectors. See *Standard Configuration: Cable Pinouts* on page 57 and *Light Control Configuration: Cable Pinouts* on page 64 for pinout information.

## Cable 300-0289

Use cable 300-0289 with the light control configuration of the UPIO board. This cable consists of a 15-pin HD-15M connector designated P1, breaking out to four RJ-11 connectors, designated P2 through P5. Modular RJ-11 couplers are provided to convert the male RJ-11 ends of the cable to female RJ-11 connectors. Figure 27 shows the cable and couplers.

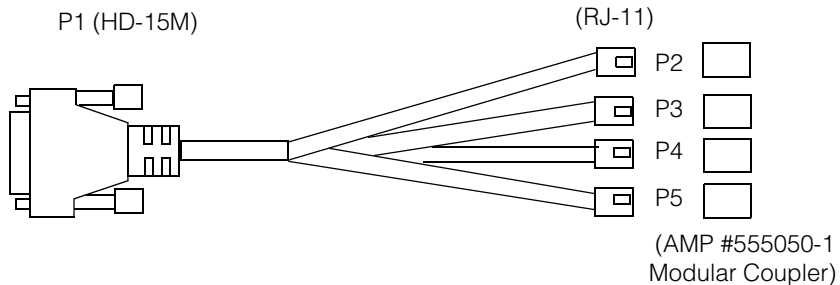

Figure 27. Cable 300-0289

When using cable 300-0289, connect your AcuLight and UltraLight light controller modules to the modular couplers at the end of the cable, using North American standard four-wire RJ-11 telephone cable.

**Note** Always use the modular coupler (Amp part number 555050-1) provided with this cable. Other RJ-11 couplers, especially those provided for home telephone wiring, may look the same but do not provide the same wiring configuration internally, and may reverse the bright and dark field light control lines.

See *Light Control Configuration: Cable Pinouts* on page 64 for pinout information.

## Standard UPIO Configuration

Use the standard configuration of the UPIO board when your application requires the maximum flexibility in PIO signaling or when you need to create a custom PIO connector. The standard configuration passes all 24 TTL signal lines and all 4 pairs of opto-isolated signals from the associated Cognex vision board.

Figure 28 shows the overall setup of the standard configuration UPIO board.

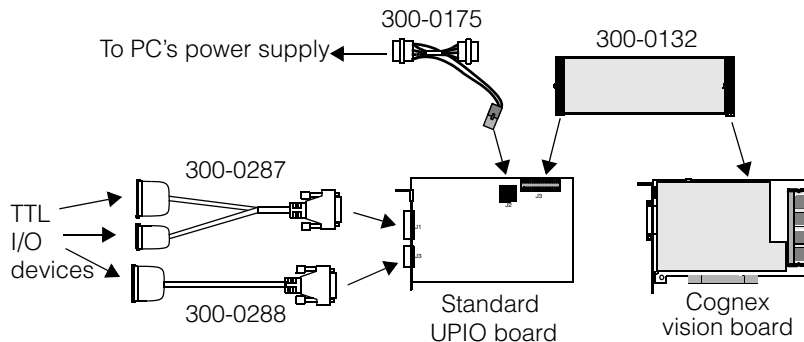

Figure 28. Setup of standard configuration UPIO board

## Standard Configuration: Cable Pinouts

For the standard configuration, connect your PIO devices as follows:

- Connect wires from PIO devices such as triggers and strobes to the screw terminal connectors on the two branch ends of the cable 300-0287, which is connected to the UPIO board's 26-pin port.
- Connect wires from additional PIO devices to the screw terminal connectors on the end of cable 300-0288, which is connected to the UPIO board's 15-pin port.

## Standard Configuration: Pinout of Cable 300-0287

Table 14 lists the pinout for cable 300-0287's 16-pin device connection terminals when used with the standard configuration UPIO board. See *Screw Terminal Connectors* on page 74 for the location of pin 1.

Pin	Signal from vision board on 16-pin terminal	Device Connection
1	TTL_IN_5	Trigger 1
2	TTL_IN_6	Trigger 2
3	TTL_IN_7	Trigger 3
4	TTL_IN_8	Trigger 4
5	TTL_BI_5	Any TTL input or output

Table 14. Device connection pinout for 16-position branch of cable 300-0287

Pin	Signal from vision board on 16-pin terminal	Device Connection
6	TTL_BI_6	Any TTL input or output
7	TTL_BI_7	Any TTL input or output
8	TTL_BI_8	Any TTL input or output
9	OPTO_OUT1+	Strobe 1
10	OPTO_OUT1-	
11	OPTO_OUT2+	Strobe 2
12	OPTO_OUT2-	
13	OPTO_OUT3+	Strobe 3
14	OPTO_OUT3-	
15	OPTO_OUT4+	Strobe 4
16	OPTO_OUT4-	

Table 14. Device connection pinout for 16-position branch of cable 300-0287

Table 15 lists the pinout for cable 300-0287's 10-pin device connection terminals when used with the standard configuration UPIO board. See *Screw Terminal Connectors* on page 74 for the location of pin 1.

Pin	Signal from vision board on 10-pin terminal	Device Connection
1	TTL_GND	Common TTL Ground
2	TTL_GND	Common TTL Ground
3	TTL_IN_1	Any TTL input
4	NC	No connect
5	TTL_IN_2	Any TTL input
6	NC	No connect
7	TTL_IN_3	Any TTL input
8	NC	No connect

Table 15. Device connection pinout for 10-position branch of cable 300-0287

Pin	Signal from vision board on 10-pin terminal	Device Connection
9	TTL_IN_4	Any TTL input
10	NC	No connect

Table 15. Device connection pinout for 10-position branch of cable 300-0287

### Standard Configuration: Pinout of Cable 300-0288

Table 16 lists the pinout for cable 300-0288's device connection terminals when used with the standard configuration UPIO board. See *Screw Terminal Connectors* on page 74 for the location of pin 1.

Pin	Signal from vision board	Device Connection
1	TTL_BI_1	Any TTL input or output
2	TTL_BI_2	Any TTL input or output
3	TTL_BI_3	Any TTL input or output
4	TTL_BI_4	Any TTL input or output
5	TTL_OUT_1	Any TTL output
6	TTL_OUT_2	Any TTL output
7	TTL_OUT_3	Any TTL output
8	TTL_OUT_4	Any TTL output
9	TTL_OUT_5	Any TTL output
10	TTL_OUT_6	Any TTL output
11	TTL_OUT_7	Any TTL output
12	TTL_OUT_8	Any TTL output
13	TTL GND	Common TTL ground
14	TTL GND	Common TTL ground
15	TTL GND	Common TTL ground
16	Key plug	No connection

Table 16. Device connection pinout for cable 300-0288

## Standard Configuration: Port Pinouts

The pinout tables in this section are provided as an aid in constructing your own PIO cables. Cognex does not support the connection of I/O devices directly to the ports on the faceplate of the UPIO board.

### Standard Configuration: Pinout of DB-26F Port

Table 17 lists the pinout of the standard configuration UPIO board's 26-pin main I/O port.

Pin	Signal from vision board	Device Connection
1	TTL_IN_1	Any TTL input
2	TTL_IN_2	Any TTL input
3	TTL_IN_3	Any TTL input
4	TTL_IN_4	Any TTL input
5	TTL_IN_5	Trigger 1
6	TTL_IN_6	Trigger 2
7	TTL_IN_7	Trigger 3
8	TTL_IN_8	Trigger 4
9	TTL_BI_5	Any TTL input or output
10	TTL_BI_6	Any TTL input or output
11	TTL_BI_7	Any TTL input or output
12	TTL_BI_8	Any TTL input or output
13	OPTO_OUT1-	Strobe 1-
14	OPTO_OUT2-	Strobe 2-
15	OPTO_OUT3-	Strobe 3-
16	OPTO_OUT4-	Strobe 3-
17	NC	No connect
18	OPTO_OUT1+	Strobe 1+

Table 17. Pinout of 26-pin main parallel I/O connector

<b>Pin</b>	<b>Signal from vision board</b>	<b>Device Connection</b>
19	OPTO_OUT2+	Strobe 2+
20	TTL GND	Common TTL Ground
21	OPTO_OUT3+	Strobe 3+
22	OPTO_OUT4+	Strobe 4+
23	NC	No connect
24	TTL GND	Common TTL Ground
25	NC	No connect
26	NC	No connect

*Table 17. Pinout of 26-pin main parallel I/O connector*

### Standard Configuration: Pinout of HD-15F Port

Table 18 lists the pinout of the standard configuration UPIO board's 15-pin auxiliary I/O port.

<b>Pin</b>	<b>Signal from vision board</b>	<b>Device Connection</b>
1	TTL_OUT_1	Any TTL output
2	TTL GND	Common TTL Ground
3	TTL_OUT_6	Any TTL output
4	TTL_OUT_8	Any TTL output
5	TTL_BI_2	Any TTL input or output
6	TTL_OUT_2	Any TTL output
7	TTL_OUT_4	Any TTL output
8	TTL GND	Common TTL Ground
9	TTL_BI_1	Any TTL input or output
10	TTL_BI_3	Any TTL input or output

*Table 18. Pinout of 15-pin auxiliary parallel I/O connector*

Pin	Signal from vision board	Device Connection
11	TTL_OUT_3	Any TTL output
12	TTL_OUT_5	Any TTL output
13	TTL_OUT_7	Any TTL output
14	TTL_GND	Common TTL Ground
15	TTL_BI_4	Any TTL input or output

Table 18. Pinout of 15-pin auxiliary parallel I/O connector

## Light Control UPIO Configuration

The light control configuration of the UPIO board provides the following signal lines:

- 4 TTL input signal lines, selectable as trigger lines
- 4 pairs of opto-isolated input signal lines, selectable as trigger lines
- 4 pairs of opto-isolated output signal lines, typically used for strobes
- 4 bidirectional TTL signal lines
- Signals on the 15-pin auxiliary PIO port are adapted to support dynamic lighting control for up to four cameras.

In this configuration, The 4 opto-isolated input pairs are converted to TTL logic on the board and are mapped to four TTL input lines on the vision board. Either the 4 TTL input lines or the 4 opto-isolated pairs of input lines can be jumper-selected to serve as hardware trigger lines.

Figure 29 shows the overall setup of the light control configuration UPIO board.

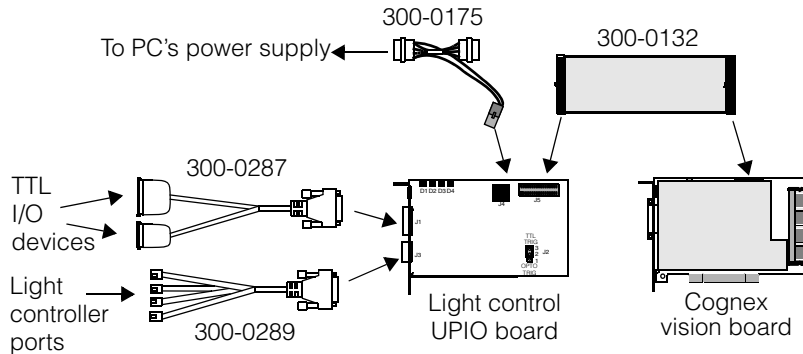

Figure 29. Setup of light control configuration UPIO board

## Light Power Source and Fuses

Lights are powered by a fused power line through the external power supply connector, J4. The light control configuration provides +12 V power on four pins of the 15-pin auxiliary PIO port. These pins are fused with a 0.5 A PolySwitch resettable fuse to provide overcurrent protection.

## Light Power Indicator LEDs

Four LEDs near the top edge of the UPIO board show the status of the PolySwitch resettable fuses for the light control lines. Light ports 0 through 3 are associated with camera ports 0 through 3, and with LEDs 1 through 4 as shown in Figure 30.

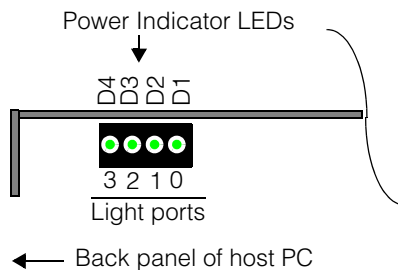

Figure 30. Top view of light control UPIO board showing LEDs

The LEDs are normally illuminated when power is on. When an LED is off, it indicates an overcurrent fault on the associated device port. The ports are protected by PolySwitch resettable fuses, so that removing the overcurrent condition should re-illuminate the LED. If all four indicators are out, it indicates a bad power source.

**Note** Overcurrent conditions should be corrected immediately.

## OPTO/TTL Trigger Selection Jumper

The light control configuration of the UPIO board provides 4 TTL input lines and 4 optically-isolated (OPTO) pairs of input lines. The OPTO/TTL trigger selection jumper, J2, permits selection of either the OPTO input lines or the TTL input lines to be mapped to the four dedicated hardware trigger inputs of the associated vision board. This gives you the option of optically-isolating your trigger input signals.

**Note** The opto-isolation circuitry requires turn-on and turn-off pulse widths of at least 250 microseconds. Then, the OPTO signals are converted to TTL logic before being mapped to the vision board's TTL\_IN lines. The combination of opto-isolation and TTL conversion circuitry means that optically-isolated triggers will be slower than comparable TTL input lines used as triggers. For trigger pulse widths smaller than 250 microseconds, it is not guaranteed that the OPTO lines can recognize individual pulses.

Use jumper J2 as described in Table 19.

Jumper J2 position	Effect	Connect trigger device wires to
No jumper, or pins 2-3 covered (TTL TRIG)	26-pin ports's four OPTO_IN pairs are converted to TTL and mapped to the 40-pin port's TTL_IN[1-4] lines	TTL_IN_[5-8] (same as standard and external UPIO configurations)
Pins 1-2 covered. (OPTO TRIG)	26-pin port's four OPTO_IN pairs are converted to TTL and mapped to the 40-pin port's TTL_IN[5-8] lines	OPTO_IN[1-4]+ and OPTO_IN[1-4]-

Table 19. OPTO/TTL jumper selection

## Light Control Configuration: Cable Pinouts

For the light control configuration, connect your PIO devices as follows:

- Connect wires from PIO devices such as triggers and strobes to the screw terminal connectors on the two branch ends of the cable 300-0287, which is connected to the UPIO board's 26-pin port.
- Connect your AcuLight or UltraLight light controllers with North American standard four-conductor RJ-11 telephone cables to the modular couplers on the branch ends of cable 300-0289, which is connected to the UPIO board's 15-pin port.

**Note** Always use the modular coupler (Amphenol part number 555050) provided with this cable. Other couplers may look the same but may not provide the same wiring pinout internally, and may reverse the bright and dark field light control lines.

### Light Control Configuration: Pinout of Cable 300-0287

Table 14 lists the pinout for cable 300-0287's 16-pin device connection terminals when used with the light control configuration UPIO board. See *Screw Terminal Connectors* on page 74 for the location of pin 1.

Pin	Signal on 16-pin terminal	Device connection when J2 = TTL Trig	Device connection when J2 = OPTO Trig
1	TTL_IN_5	Trigger 1	Any TTL input, remapped to TTL_IN_1
2	TTL_IN_6	Trigger 2	Any TTL input, remapped to TTL_IN_2
3	TTL_IN_7	Trigger 3	Any TTL input, remapped to TTL_IN_3
4	TTL_IN_8	Trigger 4	Any TTL input, remapped to TTL_IN_4
5	TTL_BI_5	Any TTL input or output	Any TTL input or output
6	TTL_BI_6	Any TTL input or output	Any TTL input or output
7	TTL_BI_7	Any TTL input or output	Any TTL input or output
8	TTL_BI_8	Any TTL input or output	Any TTL input or output
9	OPTO_OUT1+	Strobe 1	Strobe 1
10	OPTO_OUT1-		
11	OPTO_OUT2+	Strobe 2	Strobe 2
12	OPTO_OUT2-		
13	OPTO_OUT3+	Strobe 3	Strobe 3
14	OPTO_OUT3-		

Table 20. Device connection pinout for 16-position branch of cable 300-0287

Pin	Signal on 16-pin terminal	Device connection when J2 = TTL Trig	Device connection when J2 = OPTO Trig
15	OPTO_OUT4+	Strobe 4	Strobe 4
16	OPTO_OUT4-		

Table 20. Device connection pinout for 16-position branch of cable 300-0287

Table 15 lists the pinout for cable 300-0287's 10-pin device connection terminals when used with the light control configuration UPIO board. See *Screw Terminal Connectors* on page 74 for the location of pin 1.

Pin	Signal on 10-pin terminal	Device connection when J2 = TTL Trig	Device connection when J2 = OPTO Trig
1	TTL GND	Common TTL Ground	Common TTL Ground
2	TTL GND	Common TTL Ground	Common TTL Ground
3	OPTO_IN1+	Any OPTO input (remapped to TTL_IN_1)	OPTO trigger 1 (remapped to TTL_IN_5)
4	OPTO_IN1-		
5	OPTO_IN2+	Any OPTO input (remapped to TTL_IN_2)	OPTO trigger 2 (remapped to TTL_IN_6)
6	OPTO_IN2-		
7	OPTO_IN3+	Any OPTO input (remapped to TTL_IN_3)	OPTO trigger 3 (remapped to TTL_IN_7)
8	OPTO_IN3-		
9	OPTO_IN4+	Any OPTO input (remapped to TTL_IN_4)	OPTO trigger 4 (remapped to TTL_IN_8)
10	OPTO_IN4-		

Table 21. Device connection pinout for 10-position branch of cable 300-0287

## Light Control Configuration: Pinout of Cable 300-0289

Table 22 lists the signal pinout for cable 300-0289, which is only used with the light control configuration of the UPIO board.

Signal from 15-pin port of UPIO board	P1 Pin Number	P2 Pin Number	P3 Pin Number	P4 Pin Number	P5 Pin Number
Cam 0 bright field *	1	3			
+12V_LIGHTS_0	6	1, 4			
Cam 0 dark field *	11	2			
GND	2				
Cam 1 bright field *	7		3		
+12V_LIGHTS_1	12		1, 4		
Cam 1 dark field *	3		2		
GND	8				
Cam 2 bright field *	13			3	
+12V_LIGHTS_2	4			1, 4	
Cam 2 dark field *	9			2	
GND	14				
Cam 3 bright field *	5				3
+12V_LIGHTS_3	10				1, 4
Cam 3 dark field *	15				2

Table 22. Pinout of cable 300-0289

Figure 31 shows pin numbering of the RJ-11 modular couplers.



Figure 31. Pin numbering of RJ-11

## Light Control Configuration: Port Pinouts

The pinout tables in this section are provided as an aid in constructing your own PIO cables. Cognex does not support the connection of I/O devices directly to the ports on the faceplate of the UPIO board.

### Light Control Configuration: Pinout of DB-26F Port

Table 17 lists the pinout of the light control configuration UPIO board's 26-pin main I/O port.

Pin	Signal	Device Connection J2 = TTL Trig	Device Connection J2 = OPTO Trig
1	OPTO_IN1+	Any TTL input (maps to vision board's TTL_IN_1)	Trigger 1 (maps to vision board's TTL_IN_5)
2	OPTO_IN2+	Any TTL input (maps to vision board's TTL_IN_2)	Trigger 2 (maps to vision board's TTL_IN_6)
3	OPTO_IN3+	Any TTL input (maps to vision board's TTL_IN_3)	Trigger 3 (maps to vision board's TTL_IN_7)
4	OPTO_IN4+	Any TTL input (maps to vision board's TTL_IN_4)	Trigger 4 (maps to vision board's TTL_IN_8)
5	TTL_IN_5	Trigger 1 (maps to vision board's TTL_IN_5)	Any TTL input (maps to vision board's TTL_IN_1)
6	TTL_IN_6	Trigger 2 (maps to vision board's TTL_IN_6)	Any TTL input (maps to vision board's TTL_IN_2)
7	TTL_IN_7	Trigger 3 (maps to vision board's TTL_IN_7)	Any TTL input (maps to vision board's TTL_IN_3)
8	TTL_IN_8	Trigger 4 (maps to vision board's TTL_IN_8)	Any TTL input (maps to vision board's TTL_IN_4)
9	TTL_BI_5	Any TTL input or output	Any TTL input or output
10	TTL_BI_6	Any TTL input or output	Any TTL input or output
11	TTL_BI_7	Any TTL input or output	Any TTL input or output
12	TTL_BI_8	Any TTL input or output	Any TTL input or output
13	OPTO_OUT1-	Strobe 1-	Strobe 1-

Table 23. Pinout of 26-pin main parallel I/O connector

Pin	Signal	Device Connection J2 = TTL Trig	Device Connection J2 = OPTO Trig
14	OPTO_OUT2-	Strobe 2-	Strobe 2-
15	OPTO_OUT3-	Strobe 3-	Strobe 3-
16	OPTO_OUT4-	Strobe 3-	Strobe 3-
17	OPTO_IN4-	Negative wire of OPTO_IN4	Negative wire of OPTO_IN4
18	OPTO_OUT1+	Strobe 1+	Strobe 1+
19	OPTO_OUT2+	Strobe 2+	Strobe 2+
20	TTL GND	Common TTL Ground	Common TTL Ground
21	OPTO_OUT3+	Strobe 3+	Strobe 3+
22	OPTO_OUT4+	Strobe 4+	Strobe 4+
23	OPTO_IN1-	Negative wire of OPTO_IN1	Negative wire of OPTO_IN1
24	TTL GND	Common TTL Ground	Common TTL Ground
25	OPTO_IN2-	Negative wire of OPTO_IN2	Negative wire of OPTO_IN2
26	OPTO_IN3-	Negative wire of OPTO_IN3	Negative wire of OPTO_IN3

Table 23. Pinout of 26-pin main parallel I/O connector

### Light Control Configuration: Pinout of HD-15F Port

Table 18 lists the pinout of the light control configuration UPIO board's 15-pin lights port.

Pin	Signal
1	Camera 0 bright field
2	GND
3	Camera 1 dark field
4	+12V_LIGHTS_2
5	Camera 3 bright field
6	+12V_LIGHTS_0

Table 24. Pinout of 15-pin auxiliary parallel I/O connector

Pin	Signal
7	Camera 1 bright field
8	GND
9	Camera 2 dark field
10	+12V_LIGHTS_3
11	Camera 0 dark field
12	+12V_LIGHTS_1
13	Camera 2 bright field
14	GND
15	Camera 3 dark field

Table 24. Pinout of 15-pin auxiliary parallel I/O connector

## External UPIO Configuration

The external configuration of the UPIO board is designed as an adjunct to the Cognex external parallel I/O module. The external I/O module is described in *External I/O Module* on page 76.

**Note** The external configuration UPIO board cannot be used by itself, or only with cables. It *must* be used in combination with the external I/O module.

Use the external UPIO board and I/O module combination when your application requires the maximum number of opto-isolated inputs and outputs. The combination provides 8 pairs of OPTO inputs and 8 pairs of OPTO outputs. An additional 8 TTL output lines and 4 TTL bidirectional lines are also provided.

Figure 32 shows the overall setup of the external configuration UPIO board with external I/O module.

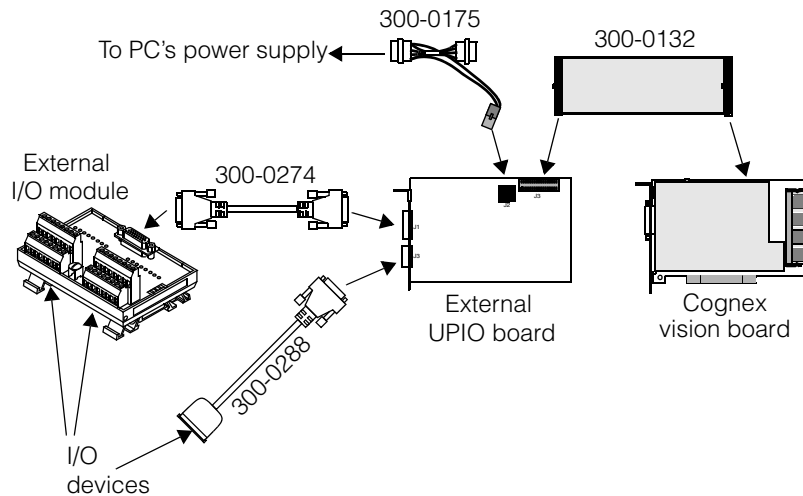

Figure 32. Setup of external configuration UPIO board

## External Configuration: Cable Pinouts

For the external configuration, connect your PIO devices as follows:

- Connect wires from PIO devices such as triggers and strobes to the screw terminal connectors on the external I/O module.
- Connect wires from additional PIO devices to the screw terminal connectors on the end of cable 300-0288, which is connected to the UPIO board's 15-pin port.

## External Configuration: Pinout of External I/O Module

For the pinout of the input terminals on the external I/O module, see Table 27 on page 80; for the output terminals, see Table 28 on page 81.

## External Configuration: Pinout of Cable 300-0288

Table 25 lists the pinout for cable 300-0288's device connection terminals when used with the external configuration UPIO board. (Note that Table 25 is the same as Table 16 on page 59 for the standard configuration.) See *Screw Terminal Connectors* on page 74 for the location of pin 1.

Pin	Signal from vision board	Device Connection
1	TTL_BI_1	Any TTL input or output
2	TTL_BI_2	Any TTL input or output
3	TTL_BI_3	Any TTL input or output
4	TTL_BI_4	Any TTL input or output
5	TTL_OUT_1	Any TTL output
6	TTL_OUT_2	Any TTL output
7	TTL_OUT_3	Any TTL output
8	TTL_OUT_4	Any TTL output
9	TTL_OUT_5	Any TTL output
10	TTL_OUT_6	Any TTL output
11	TTL_OUT_7	Any TTL output
12	TTL_OUT_8	Any TTL output
13	TTL GND	Common TTL ground
14	TTL GND	Common TTL ground
15	TTL GND	Common TTL ground
16	Key plug	No connection

Table 25. Device connection pinout for cable 300-0288

## External Configuration: Port Pinouts

The pinout tables in this section are provided as an aid in constructing your own PIO cables. Cognex does not support the connection of I/O devices directly to the ports on the faceplate of the UPIO board.

## External Configuration: Pinout of DB-26F Port

The 26-pin main I/O port on the external configuration UPIO board *must* be connected to the Cognex external I/O module, using cable 300-0274. The external configuration UPIO board converts all OPTO signals from the associated vision board into TTL signals; it also inverts polarity on certain signals. The board makes these signal conversions in anticipation of them being corrected by the external I/O module. The external I/O module takes all the TTL signals it is given, corrects their polarity, and opto-isolates them. Thus, the converted signals at the 26-pin port of the external configuration UPIO board are not of any value without the reconversion that takes place on the external I/O module. For this reason, the pinout of the 26-pin port is not given.

## External Configuration: Pinout of HD-15F Port

Table 26 shows the pinout of the external configuration UPIO board's 15-pin auxiliary I/O port. (Note that Table 26 is the same as Table 18 on page 61, which shows the same information for the standard configuration board.)

Pin	Signal from vision board	Device Connection
1	TTL_OUT_1	Any TTL output
2	TTL_GND	Common TTL Ground
3	TTL_OUT_6	Any TTL output
4	TTL_OUT_8	Any TTL output
5	TTL_BI_2	Any TTL input or output
6	TTL_OUT_2	Any TTL output
7	TTL_OUT_4	Any TTL output
8	TTL_GND	Common TTL Ground
9	TTL_BI_1	Any TTL input or output
10	TTL_BI_3	Any TTL input or output
11	TTL_OUT_3	Any TTL output
12	TTL_OUT_5	Any TTL output
13	TTL_OUT_7	Any TTL output

Table 26. Pinout of 15-pin auxiliary parallel I/O connector

Pin	Signal from vision board	Device Connection
14	TTL GND	Common TTL Ground
15	TTL_BI_4	Any TTL input or output

Table 26. Pinout of 15-pin auxiliary parallel I/O connector

## Screw Terminal Connectors

The Cognex PIO breakout cables 300-0287 and 300-0288 terminate in screw terminal connectors. Screw terminal connectors come in standard sizes, according to the number of terminal positions. Figure 33 shows a 16-position screw terminal connector and the mating Cognex cable connector face.

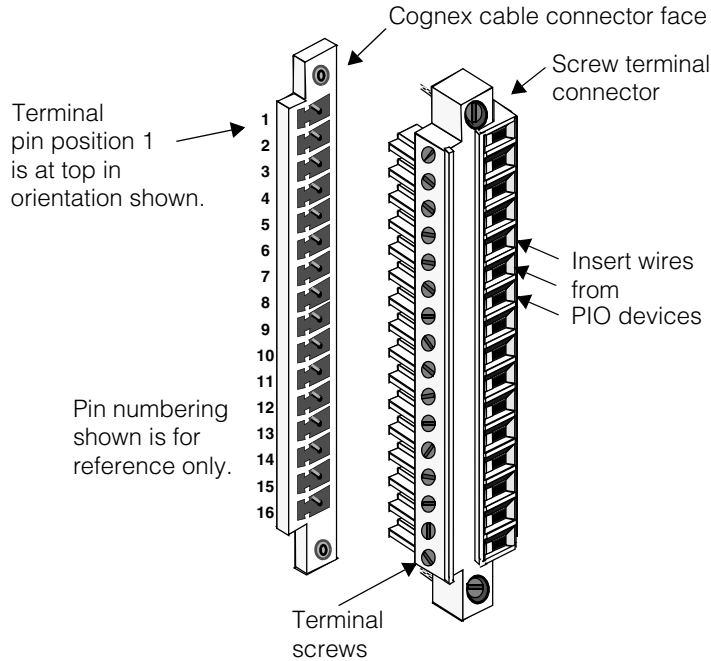

Figure 33. Screw terminal connectors

The 10-position terminal connectors used in cable 300-0287 are similar to Figure 33 except for the number of terminals.

## Parallel I/O Circuit Logic

See the discussions and circuit logic diagrams in the following sections to help you decide how to hook up I/O devices to cables 300-0287 and 300-0288:

- *Parallel Input (Trigger) Lines* on page 38
- *Parallel Output Lines* on page 39
- *Parallel Bidirectional Lines* on page 39
- *Opto-Isolated Output (Strobe) Lines* on page 40
- *Using Optically Isolated Outputs* on page 40

## External I/O Module

The Cognex external I/O module, P/N 800-5712-2, connects to the 26-pin I/O port of the parallel I/O board in the external configuration (P/N 800-5726-3). It serves as an opto-isolated connection point for parallel I/O signal lines originating in the vision processor.

Capabilities of the external I/O module include:

- 8 optically isolated inputs and 8 optically isolated outputs
- Signal voltage, 5 V to 24 V DC at 15 mA
- Optical isolation for the both inputs and outputs
- LEDs to indicate the state of each line
- Powered from the host vision processor
- DIN standard rail mounting

## Layout

Figure 34 shows the layout and major components of the external I/O module.

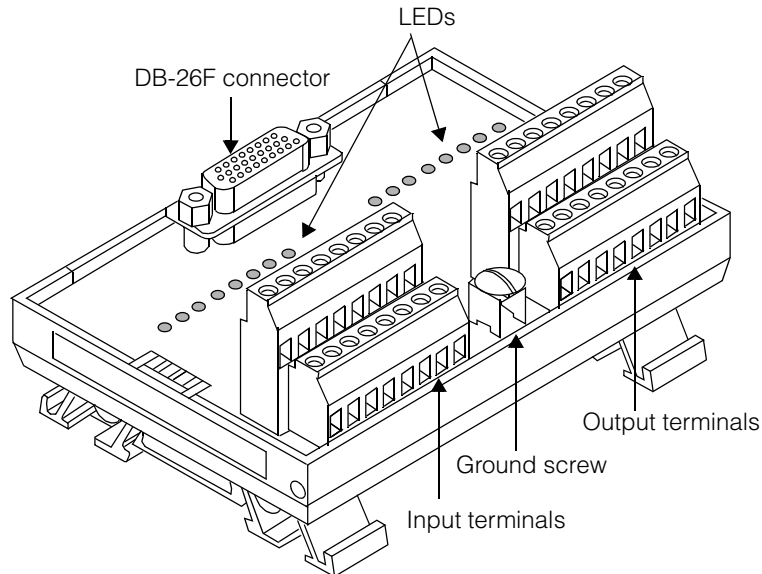

Figure 34. Parts layout of external I/O module

The DB-26F connector provides a connection from the universal parallel I/O board through Cognex cable P/N 300-0274. The input and output terminals provide connection points for connecting wires from triggers, strobes, or other parallel I/O devices. The LEDs indicate the availability of power to the input and output lines.

## Installation

The external I/O module can only be used with the universal parallel I/O board in its external configuration.

### **Caution**

*The external I/O module must have the same ground potential as the chassis of the PC containing the vision system. Any difference in potential can damage the equipment. If you connect a ground wire to the I/O module ground screw, then that ground must have the same potential as the vision system host's ground.*

To install an external I/O module, perform the following steps:

1. Ensure that the external configuration of the universal parallel I/O board (P/N 800-5726-3) is installed.
2. Attach the external I/O module to a convenient surface. It is configured for a standard #3 DIN rail mounting.
3. Remove power from the host PC.
4. Plug one end of the external I/O cable (P/N 300-0274) into the 26-pin connector of the external I/O module and the other end into the external 26-pin connector of the parallel I/O board.
5. Connect input signal lines to the input screw terminals on the external I/O module and tighten the set screws. See *Signal Lines* on page 78 and *Input Terminal Block* on page 80 for pinout and wiring information.
6. Connect output signal lines to the output screw terminals on the external I/O module and tighten the set screws. See *Signal Lines* on page 78 and *Output Terminal Block* on page 81 for pinout and wiring information.

## Signal Lines

Figure 35 shows the methods for connecting input and output signal lines to the respective terminal plugs of the external I/O module.

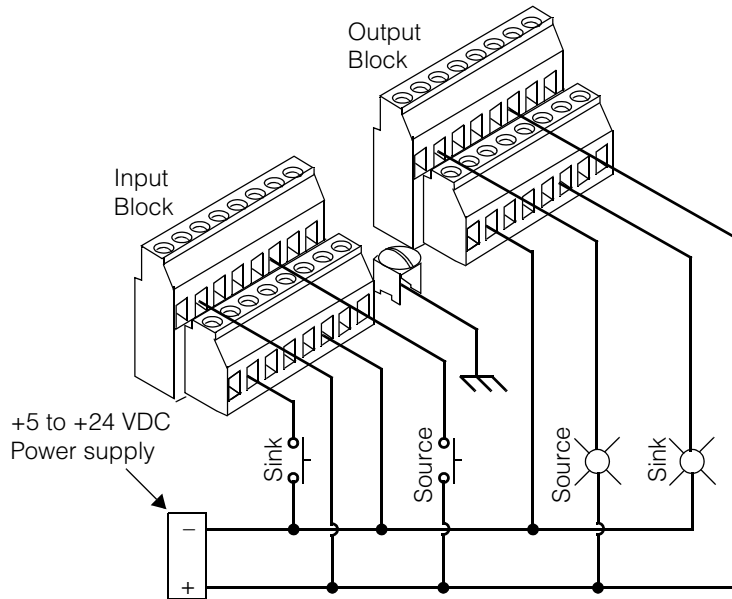

Figure 35. Wiring methods for connecting to the external I/O module

For both input and output signal lines, connect the source side of the signal to a positive-numbered terminal and the sink side to a negative-numbered terminal.

## Mechanical and Electrical Specifications

The following table lists the mechanical and electrical specifications for the external I/O module:

Specification	Description
Dimensions	4.688 in (width) X 2.375 in (height) X 3.25 in (depth) 1.91 cm (width) X 6.03 cm (height) X 8.26 cm (depth)
Mounting	#3 DIN rail mountable
Operating Voltage (Field Side)	5 V to 24 V DC

Specification	Description
Power	+5 V DC, supplied from the vision system
Maximum Output Current	24 mA (sink or source)
ON State Voltage Drop	0.8 V DC @ 10 mA, 2.6 V DC @ 24 mA
OFF State Leakage Current	100 $\mu$ A maximum @ 15 V DC
Output Delay	ON: 6 $\mu$ Sec OFF: 130 $\mu$ Sec @ 5 mA; 95 $\mu$ Sec @ 10 mA; 85 $\mu$ Sec @ 15 mA
Input Resistance	~1000 Ohms
Input State Current	ON: 3.5 to 24 mA OFF: 500 $\mu$ A
Input Delay	ON: 30 $\mu$ Sec @ 3.5 mA; 8 $\mu$ Sec @ 15 mA OFF: 45 $\mu$ Sec @ 3.5 mA; 80 $\mu$ Sec @ 15 mA
Field Wiring Size	26 to 12 AWG
Terminal Block Torque	Maximum 0.8 (7) N-M (in-lbf)
Cable	7 feet (2.1 meter, supplied)
Environmental	Operating Temperature: 0 to 50° C Storage Temperature: -20 to 85° C Relative Humidity: 5 to 95 percent non-condensing

## LED Numbering

The external I/O module has silk-screened labels identifying the LEDs for each input and output plus/minus connection pair. The labels identify the connection points with zero-based numbers, IN0 through IN7, and OUT0 through OUT7.

Cognex software uses one-based numbers in the names of parallel I/O signals. Remember to transpose the connection point numbers to the Cognex signal numbers, as shown in Table 27 on page 80 and Table 28 on page 81.

# Input Terminal Block

Figure 36 shows the pin numbering for the input terminal block.

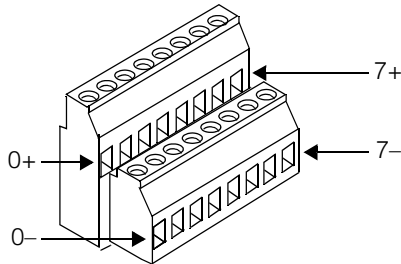

Figure 36. Pin numbering for input terminal block

Table 27 lists the pinout for the input block.

TTL signal from frame grabber	Opto-isolated and used as	Pin Number	Device Connection
TTL_IN_1	TTL_IN_1+	0+	Any input
	TTL_IN_1-	0-	
TTL_IN_2	TTL_IN_2+	1+	Any input
	TTL_IN_2-	1-	
TTL_IN_3	TTL_IN_3+	2+	Any input
	TTL_IN_3-	2-	
TTL_IN_4	TTL_IN_4+	3+	Any input
	TTL_IN_4-	3-	
TTL_IN_5	TTL_IN_5+	4+	Trigger 1
	TTL_IN_5-	4-	
TTL_IN_6	TTL_IN_6+	5+	Trigger 2
	TTL_IN_6-	5-	
TTL_IN_7	TTL_IN_7+	6+	Trigger 3
	TTL_IN_7-	6-	

Table 27. Pinout for input block of external I/O option

TTL signal from frame grabber	Opto-isolated and used as	Pin Number	Device Connection
TTL_IN_8	TTL_IN_8+	7+	Trigger 4
	TTL_IN_8-	7-	

Table 27. Pinout for input block of external I/O option

## Output Terminal Block

Figure 37 shows the pin numbering for the output terminal block.

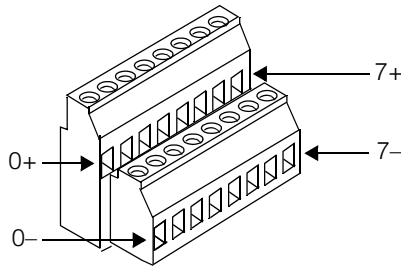

Figure 37. Pin numbering for output terminal block

Table 28 lists the pinout for the output terminal block.

TTL signal from frame grabber	Opto-isolated and used as	Pin Number	Device Connection
TTL_BI_5	TTL_BI_5+	0+	Any output (no longer bidirectional)
	TTL_BI_5-	0-	
TTL_BI_6	TTL_BI_6+	1+	Any output (no longer bidirectional)
	TTL_BI_6-	1-	
TTL_BI_7	TTL_BI_7+	2+	Any output (no longer bidirectional)
	TTL_BI_7-	2-	
TTL_BI_8	TTL_BI_8+	3+	Any output (no longer bidirectional)
	TTL_BI_8-	3-	

Table 28. Pinout for output block of external I/O option

TTL signal from frame grabber	Opto-isolated and used as	Pin Number	Device Connection
OPTO_OUT1	OPTO_OUT1+	4+	Strobe 1
	OPTO_OUT1-	4-	
OPTO_OUT2	OPTO_OUT2+	5+	Strobe 2
	OPTO_OUT2-	5-	
OPTO_OUT3	OPTO_OUT3+	6+	Strobe 3
	OPTO_OUT3-	6-	
OPTO_OUT4	OPTO_OUT4+	7+	Strobe 4
	OPTO_OUT4-	7-	

Table 28. Pinout for output block of external I/O option

## External I/O Module Adds Conversion Delay

The external I/O module converts all digital TTL signals from the frame grabber into opto-isolated signal pairs for both input and output lines. Specifically, this conversion affects TTL\_BI lines 5-8 and all eight TTL\_IN lines. The four OPTO\_OUT line pairs used for connecting strobe signals are converted twice: they begin as opto pairs on the frame grabber board, are converted to TTL lines on the parallel I/O board, and are converted back to opto pairs in the external I/O module.

The opto-isolation circuitry of the external I/O module adds a delay of 100 to 300 microseconds, compared to the TTL OUT signals on the 15-pin parallel I/O port. For comparison, the response time of TTL signals on the 15-pin port is about 1 microsecond.

For example, the same output device, connected to both the external I/O module and the 15-pin port's cable will receive its signal 100 to 300 microseconds slower on the external I/O module compared to the 15-pin port.

A delay of this small magnitude is not visible to the naked eye, but may have a cumulative effect when multiplied over many rapid image acquisitions. Take this delay into account when calculating your maximum image processing throughput if you plan to use the external I/O module.

## External I/O Module Circuit Logic

Figure 38 shows a typical input schematic to help you determine how to wire your trigger and other input devices to the external I/O module.

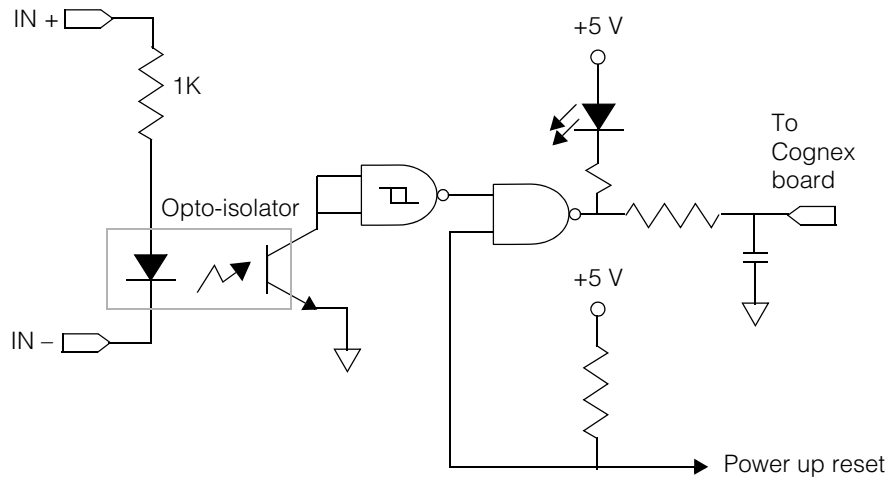

Figure 38. Typical input schematic for external I/O module

The following figure shows a typical output schematic to help you determine how to wire your strobe and other output devices to the external I/O module.

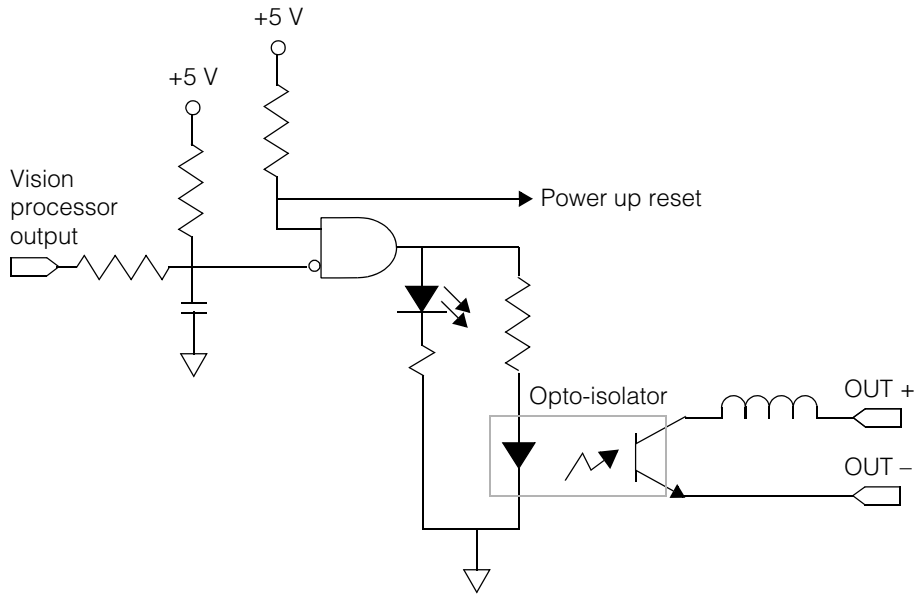

Figure 39. Typical output schematic for external I/O module

## ISA Parallel I/O Boards

Cognex continues to support the ISA parallel I/O boards so that you can continue to use your existing hardware. For new applications, use the universal parallel I/O board, which supports all of the signals of the two ISA boards combined. The universal board is described in *Universal Parallel I/O Board* beginning on page 49.

There are two ISA-based parallel I/O boards available for the MVS-8120: a TTL board (P/N 801-0003-1) and an OPTO/TTL board (P/N 801-0002-1). The board you select determines the set of I/O lines available for your application, as shown in Table 29. The two boards can be used together to access all 32 of the MVS-8120's parallel I/O signals. See *Installing Two ISA PIO Boards* on page 26 for instructions on wiring both boards together in the same PC.

Board	TTL Inputs	TTL Outputs	General TTL I/O	Opto-isolated Output pairs	Ground Pins
TTL	4	8	4	-	2
OPTO/TTL	4	-	4	4	2

Table 29. Sets of I/O lines available using the ISA parallel I/O boards

The hardware trigger feature of the MVS-8120 makes use of one or more TTL input lines and, optionally, one or more pairs of opto-isolated output lines, as described in *Hardware Triggering of Acquisitions and Strokes* on page 41. To use the hardware trigger feature with the ISA parallel I/O boards, you must install the OPTO/TTL board.

Both ISA parallel I/O boards plug into the 8-bit portion of an ISA bus slot. The boards use the bus connection for its power and ground pins, for protection against electrostatic discharge and for overlimit protection.

Figure 40 shows the layout of the TTL parallel I/O board. The OPTO/TTL board uses the same layout except where noted in the figure.

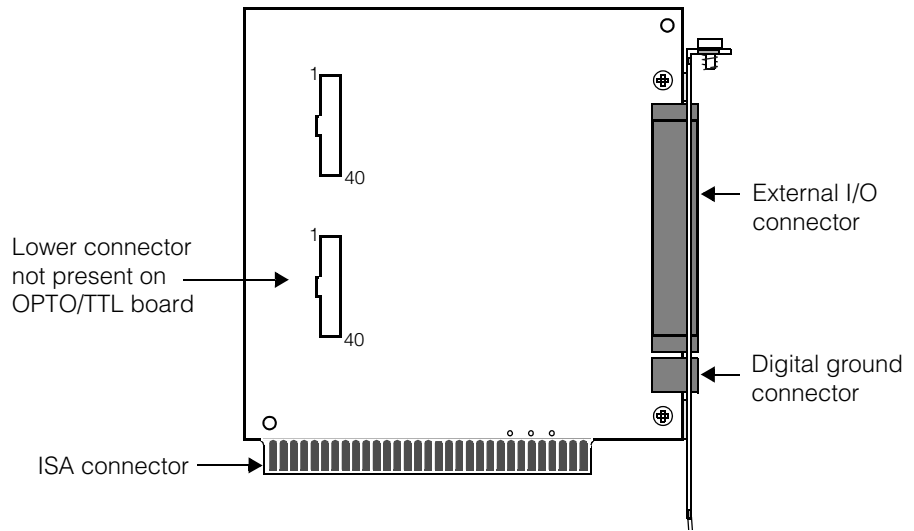

Figure 40. Layout of ISA parallel I/O boards

## Pinout Values for TTL Board

The TTL version of the ISA parallel I/O board has external I/O connector pins, which are labeled on the back panel faceplate. The pins are numbered from the top down, but are labeled on the faceplate as shown in Table 30. The connector plug (provided with each parallel I/O board), to which you attach external connection wires, is not labeled.

P/N 801-0003-01 (as labeled)		Pin	Interface Signal	Device
	1	1	$\overline{\text{TTL\_IN\_1}}$	TTL Input 1
	2	2	$\overline{\text{TTL\_IN\_2}}$	TTL Input 2
	3	3	$\overline{\text{TTL\_IN\_3}}$	TTL Input 3
	4	4	$\overline{\text{TTL\_IN\_4}}$	TTL Input 4
	1	5	TTL_BI_1	TTL I/O 1
	2	6	TTL_BI_2	TTL I/O 2
	3	7	TTL_BI_3	TTL I/O 3
	4	8	TTL_BI_4	TTL I/O 4
	1	9	TTL_OUT_1	TTL Output 1
	2	10	TTL_OUT_2	TTL Output 2
	3	11	TTL_OUT_3	TTL Output 3
	4	12	TTL_OUT_4	TTL Output 4
	5	13	TTL_OUT_5	TTL Output 5
	6	14	TTL_OUT_6	TTL Output 6
	7	15	TTL_OUT_7	TTL Output 7
	8	16	TTL_OUT_8	TTL Output 8
GND		Ground	Ground	
		Ground	Ground	

Table 30. Pinout and faceplate connector for TTL parallel board

## Pinout Values for OPTO/TTL Board

The OPTO/TTL version of the ISA parallel I/O board has external I/O connector pins, which are labeled on the back panel faceplate. The pins are numbered from the top down, but are labeled on the faceplate as shown in Table 31. The connector plug, to which you attach external connection wires, is not labeled.

P/N 801-0002-01 (as labeled)	Pin	Interface Signal	Device
	5	$\overline{\text{TTL\_IN\_5}}$	Trigger 1
	6	$\overline{\text{TTL\_IN\_6}}$	Trigger 2
	7	$\overline{\text{TTL\_IN\_7}}$	Trigger 3
	8	$\overline{\text{TTL\_IN\_8}}$	Trigger 4
	5	TTL_BI_5	TTL I/O 5
	6	TTL_BI_6	TTL I/O 6
	7	TTL_BI_7	TTL I/O 7
	8	TTL_BI_8	TTL I/O 8
	1+	OPTO_OUT1+	Strobe 1
	1-	OPTO_OUT1-	
	2+	OPTO_OUT2+	Strobe 2
	2-	OPTO_OUT2-	
	3+	OPTO_OUT3+	Strobe 3
	3-	OPTO_OUT3-	
	4+	OPTO_OUT4+	Strobe 4
	4-	OPTO_OUT4-	
GND		Ground	Ground
		Ground	Ground

Table 31. Pinout and faceplate connector for OPTO/TTL parallel board

# Cognex Video Modules and Cameras

# 4

This chapter describes one or more Cognex Video Modules (CVMs). A CVM is a factory-installed circuit board that provides video input and camera control for your frame grabber. This chapter contains the following sections:

- *Cognex Video Module Overview* on page 90 describes the physical and input characteristics of various CVMs.
- *CVM Descriptions* on page 93 describes the specifications for individual CVMs.
- *Connecting Cameras* on page 111 describes how to connect cameras to CVMs.
- *Configuring Cameras* on page 119 includes instructions for cameras that need special settings to work with Cognex software.
- *Camera I/O Electrical Specifications* on page 137 describes the electrical characteristics of the video circuits that support analog and digital cameras on various CVMs.

# Cognex Video Module Overview

This section describes your Cognex Video Module (CVM). The latest information about supported cameras for your CVM is described in the release notes supplied with your software package.

## CVM Features

A Cognex Video Module is a circuit board that provides support for connecting analog or digital video cameras to a Cognex vision system.

CVMs are only available as factory-installed circuit boards and are not user-replaceable or user-upgradeable in any way. CVMs supply camera support for several Cognex product lines.

For the MVS-8120, the CVM model number is appended to the product number following a slash.

For the MVS-8120, the following CVMs are supported:

- Model 8120/CVM1
- Model 8120/CVM4
- Model 8120/CVM6
- Model 8120/CVM9
- Model 8120/CVM11

## Video Input Capabilities

Different CVMs are distinguished by their input video capabilities. Table 32 shows the input video capabilities of current CVM models.

<b>CVM Model</b>	<b>Number of cameras supported</b>	<b>Acquisition channels</b>	<b>Cameras per acquisition channel</b>	<b>Simultaneous acquisitions</b>
<b>CVM1</b>	4 analog	4	1	4
<b>CVM4</b>	4 CVC-1000 analog	4	1	4
<b>CVM6</b>	2 digital, 1 analog	3	1	3 (See Note)

*Table 32. Video characteristics of CVM models*

<b>CVM Model</b>	<b>Number of cameras supported</b>	<b>Acquisition channels</b>	<b>Cameras per acquisition channel</b>	<b>Simultaneous acquisitions</b>
<b>CVM9</b>	2 digital, 1 analog	3	1	3 (See Note)
<b>CVM11</b>	2 digital line scan	2	1	2

Table 32. Video characteristics of CVM models

**Note** All CVM6 and CVM9 acquisition channels can be active at the same time, but none of the channels can be used in a master/slave relationship.

## CVM Connector Panels

A CVM can be distinguished by the type and number of connectors on its connector panel. When the CVM is mounted on a PCI-based frame grabber or vision processor, the CVM's connector panel becomes the PCI board's back panel, as seen from the back of the PC. Table 33 shows the connector panels for each CVM.

<b>CVM</b>	<b>Connector panel</b>			
CVM1		HD-26F (Mono analog cameras)		
CVM4		HD-60F (Cognex CVC-1000 cameras)		
CVM6 CVM9		HD-60F (Digital cameras)		HD-15F (Analog cameras)
CVM11		HD-60F (Line scan cameras)		HD-15F (Encoders)

Table 33. CVM connector panels

## CVM Video Output

For the MVS-8120 frame grabber, image output from the CVM occurs through the frame grabber's PCI bus to the host's PC's display adapter.

### Bus-Based Video Output

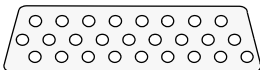
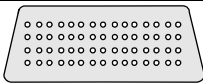
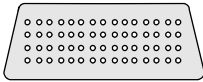
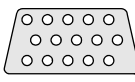
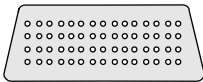
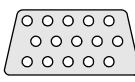
All MVS-8120 models can pass image output through the PCI bus to a PCI or AGP video display adapter, under the control of the host PC's operating system.

For bus-based image output, the video display adapter and PCI bus must meet certain minimum criteria to allow the frame grabber to transfer video images at its maximum frame rate for live video. See the section *Requirements for Maximum Frame Rate* in the *Installation* chapter for a further discussion of these minimum criteria.

# CVM Descriptions

This section includes separate descriptions of each Cognex Video Module.

## CVM1 Description

CVM1 has four independent acquisition channels, and allows the connection of up to four analog cameras. Image acquisitions can occur on all four camera channels simultaneously.

### CVM1 Camera Support

The cameras and camera cables supported on this CVM by your Cognex software package are listed in the Supported Cameras table for your software release, found in the Cognex menu of the Windows Start -> Programs list.

**Caution** *Cable 300-0316 and adapter 300-0313 are for use only with newer cameras introduced since 2000, including the Sony XC-ST/ES family and the JAI CV-A1-14.4. Do not connect these cables to the Sony XC-55 or you may damage your CVM module, your camera, or both.*

**Note** For the Teli CS8531 camera in single-tap mode, use the standard CVM1 breakout box or cable, and one to four 300-0208 camera cables, one per camera. For dual-tap mode, cable 300-0344 plugs directly into CVM1's 26-pin camera port and supports one CS8531 camera in dual-tap mode. If your application requires two CS8531's in dual-tap mode, contact Cognex Technical Support.

### CVM1 Analog Camera Port

Analog cameras are attached to CVM1 through its DB-26F connector. To connect camera cables, you must first connect a breakout box or breakout cable. For more information, see *Attaching Cameras to the CVM Breakout Box* on page 112 or *Attaching the Camera Breakout Cable* on page 114.

Figure 41 shows how the pins are numbered on the CVM's DB-26F connector.

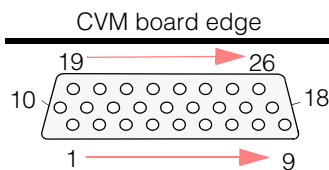

Figure 41. CVM1's DB-26F analog camera connector

Table 34 shows the pinout for the analog camera connector on CVM1.

Pin	Signal Name	Pin	Signal Name	Pin	Signal Name
1	VIDEO-Cam3	10	VDrive-Cam4	19	CTRL1-Cam4
2	GND	11	HDrive-Cam4	20	CTRL2-Cam4
3	CTRL2-Cam3	12	CTRL1-Cam3	21	+12V
4	HDrive-Cam3	13	VDrive-Cam3	22	VIDEO-Cam4
5	VIDEO-Cam2	14	GND	23	+12V
6	GND	15	CTRL1-Cam2	24	CTRL2-Cam1
7	VDrive-Cam2	16	CTRL2-Cam2	25	HDrive-Cam1
8	GND	17	HDrive-Cam2	26	VDrive-Cam1
9	VIDEO-Cam1	18	CTRL1-Cam1		

Table 34. CVM1's pinout for analog camera connector

## CVM1 Line Numbering

When using Cognex vision processing software, address the cameras as 0, 1, 2, and 3. Camera 0 is connected to breakout box (or breakout cable) port 1; camera 1 is connected to port 2; and so on.

For purposes of hooking up hardware trigger signals to a parallel I/O board, CVM1 cameras have logical positions as expected from 1 to 4. That is, to hardware trigger an image acquisition on the camera connected to breakout box (or breakout cable) port 1, connect your trigger input signal to the TTL\_IN\_5 line of the parallel I/O board. To trigger an acquisition on the camera connected to port 2, use the TTL\_IN\_6 line, and so on. Refer to *Parallel I/O Boards* on page 43 for the cable number and cable pinout for your I/O board configuration.

A strobe pair is the single logical unit formed by the plus and minus strobe signal lines with the same logical number. That is, strobe pair 1 consists of signal lines OPTO\_OUT1+ and OPTO\_OUT1-.

The four pairs of strobe signals on the parallel I/O board have logical positions 1 to 4. For CVM1, strobe pairs 1 to 4 correspond to camera ports 1 to 4. Thus, if enabled in software, a hardware image acquisition on camera port 1 simultaneously fires the strobe connected to strobe pair 1, an acquisition on camera port 2 fires the strobe on strobe pair 2, and so on.

**Note** If you use hardware triggering, the corresponding strobe line is not available under software control for any other use, even if a strobe is not connected.

CVM1's line numbering scheme is summarized in Table 35.

Camera port on breakout box or cable	Associated trigger line on parallel I/O board	Associated strobe pair on parallel I/O board	Cognex software address
1	Trigger 1 (TTL_IN_5)	Strobe pair 1 (OPTO_OUT1+ and 1-)	0
2	Trigger 2 (TTL_IN_6)	Strobe pair 2 (OPTO_OUT2+ and 2-)	1
3	Trigger 3 (TTL_IN_7)	Strobe pair 3 (OPTO_OUT3+ and 3-)	2
4	Trigger 4 (TTL_IN_8)	Strobe pair 4 (OPTO_OUT4+ and 4-)	3

*Table 35. CVM1 line numbering*

The cameras and camera cables supported on this CVM by your Cognex software package are listed in the Supported Cameras table for your software release, found in the Cognex menu of the Windows Start -> Programs list.

**Note** For the Teli CS8531 camera in single-tap mode, use the standard CVM1 breakout box or cable, and one to four 300-0208 camera cables, one per camera. For dual-tap mode, cable 300-0344 plugs directly into CVM1's 26-pin camera port and supports one CS8531 camera in dual-tap mode. To use two CS8531's in dual-tap mode, contact Cognex Technical Support.

## CVM4 Description

CVM4 is a camera control unit for the Cognex CVC-1000 camera. The CVC-1000 is a high-speed, lightweight camera head unit that requires the camera control functions resident in a separate CVM module. Thus, the CVC-1000 camera can only be used with a CVM4 module.

CVM4 can support simultaneous image acquisitions on up to four CVC-1000 cameras.

## CVM4 Camera Support

CVM4 supports a single camera, the Cognex CVC-1000. CVC-1000 cameras are connected using the Cognex cables shown in Table 36.

**Caution**

*Cameras must be connected using the Cognex cables shown in this table. Using non-Cognex camera cables could damage your vision processor, your camera, or both.*

Camera	Cognex Breakout Cable Part Number	Cognex Camera Cable Part Number
Cognex CVC-1000	Four-camera breakout cable, 300-0220	300-0223
	One-camera breakout cable, 300-0224	

Table 36. CVM4 camera cable part numbers

**Note**

CVC-1000 cameras must be connected in camera port order. See *CVC-1000 Usage Notes* on page 124 for important information on connecting CVC-1000 cameras.

## CVM4 Camera Port

CVM4's camera input port is a high-density Molex 60-pin LFH-60 female connector. This port's pin numbering is shown in Table 42.

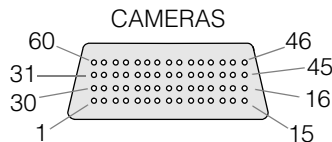

Figure 42. Pin numbering of CVM4's camera port

The pinout of the CVM4 camera port is shown in Table 37.

Pin	Signal Name	Pin	Signal Name	Pin	Signal Name
1	Chu1Video	21	Chu3Shutter+	41	Chu2Shutter-
2	Chu1VideoReturn	22	Chu3DataValid-	42	Chu2Readout+
3	Chu1SVR(0)	23	Chu3DataValid+	43	Chu2Readout-
4	Chu1SVR(1)	24	Chu3PCLK-	44	Chu2 +12 Return
5	Chu1SVR(2)	25	Chu3PCLK+	45	Chu2 +12VDC
6	Chu1PCLK+	26	Chu3SVR(2)	46	Chu4 +12VDC
7	Chu1PCLK-	27	Chu3SVR(1)	47	Chu4 +12 Return
8	Chu1DataValid+	28	Chu3SVR(0)	48	Chu4Readout-
9	Chu1DataValid-	29	Chu3VideoReturn	49	Chu4Readout+
10	Chu1Shutter+	30	Chu3Video	50	Chu4Shutter-
11	Chu1Shutter-	31	Chu2Video	51	Chu4Shutter+
12	Chu1Readout+	32	Chu2VideoReturn	52	Chu4ataValid-
13	Chu1Readout-	33	Chu2SVR(0)	53	Chu4DataValid+
14	Chu1 +12 Return	34	Chu2SVR(1)	54	Chu4PCLK-
15	Chu1 +12VDC	35	Chu2SVR(2)	55	Chu4PCLK+
16	Chu3 +12VDC	36	Chu2PCLK+	56	Chu4SVR(2)
17	Chu3 +12 Return	37	Chu2PCLK-	57	Chu4SVR(1)
18	Chu3Readout-	38	Chu2DataValid+	58	Chu4SVR(0)
19	Chu3Readout+	39	Chu2DataValid-	59	Chu4VideoReturn
20	Chu3Shutter-	40	Chu2Shutter+	60	Chu4Video

Table 37. Pinout for CVM4 camera input port

## CVM4 Line Numbering

CVM4 line numbering is identical to CVM1 line numbering, described in *CVM1 Line Numbering* on page 94.

## CVM6 and CVM9 Description

CVM6 and CVM9 have two independent acquisition channels for digital cameras and one independent acquisition channel for an analog camera.

CVM6 and CVM9 are identical, except that CVM6 supports the RS-422 standard for digital cameras, while CVM9 supports the RS-644 standard.

## CVM6 and CVM9 Camera Support

The cameras and camera cables supported on CVM6 and CVM9 by your Cognex software package are listed in the Supported Cameras table for your software release, found in the Cognex menu of the Windows Start -> Programs list.

**Caution**

*Cable 300-0318 and adapter 300-0313 are for use only with newer cameras introduced since 2000, including the Sony XC-ST/ES family and the JAI CV-A1-14.4. Do not connect these cables to the Sony XC-55 or you may damage your CVM module, your camera, or both.*

## CVM6 and CVM9 Analog Camera Port

The analog camera input port on CVM6 and CVM9 is an HD-15F D-sub connector. Pin numbering for this port is shown in Figure 43.

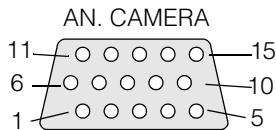

Figure 43. Pin numbering of CVM6/CVM9's analog camera port

The pinout for CVM6/CVM9's analog camera port is shown in Table 38.

Pin	Signal Name	Pin	Signal Name	Pin	Signal Name
1	No connect	6	No connect	11	GND, shield
2	Analog video	7	GND, video	12	H-DRIVE GND
3	No connect	8	CTRL2	13	H-DRIVE signal
4	+12 VDC, camera	9	+12 VDC, camera	14	V-DRIVE signal
5	GND, +12 VDC return	10	CTRL1	15	V-DRIVE GND

Table 38. Pinout of CVM6/CVM9's analog camera port

**Caution**

The analog camera connector on CVM6 and CVM9 resembles the industry-standard VGA monitor connector, but the pins are wired differently. Do not connect a monitor to the CVM or you may damage your CVM, your vision board, or your monitor.

Connect analog cameras to the HD-15 connector using one of the Cognex camera cables listed in the Supported Cameras table for your Cognex software release (See the Cognex menu of the Windows Start -> Programs menu).

## CVM6 and CVM9 Digital Camera Port

The digital video input port on CVM6 and CVM9 is a high-density 60-pin Molex LFH-60 female connector carrying signals for the connection of two digital cameras. Pin numbering for the digital video port is shown in Figure 44; its pinout is shown in Table 39.

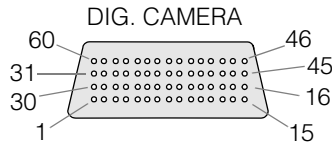

Figure 44. Pin numbering of CVM6 and CVM9 digital camera port

The digital video port must be connected to Cognex cable part number 300-0214. This Y-cable splits the signals from the CVM6/CVM9's digital video port into two AIA 68-pin digital camera ports.

Pin	Signal Name	Pin	Signal Name	Pin	Signal Name
1	CAM0_D7+(MSB+)	21	CTRL0D	41	NC
2	CAM0_D6+	22	CTRL0B	42	CAM1_VD+
3	CAM0_D5+	23	CAM0_D0-	43	CAM1_HD+
4	CAM0_D4+	24	CAM0_D1-	44	CAM1_PCLK+
5	CAM0_D3+	25	CAM0_D2-	45	GND
6	CAM0_D2+	26	CAM0_D3-	46	GND
7	CAM0_D1+	27	CAM0_D4-	47	CAM1_PCLK-
8	CAM0_D0+	28	CAM0_D5-	48	CAM1_HD-
9	CTRL0A	29	CAM0_D6-	49	CAM1_VD-
10	CTRL0C	30	CAM0_D7- (MSB-)	50	NC

Table 39. Pinout of CVM6/CVM9's digital video port

Pin	Signal Name	Pin	Signal Name	Pin	Signal Name
11	NC	31	CAM1_D7+ (MSB+)	51	CTRL1D
12	CAM0_VD+	32	CAM1_D6+	52	CTRL1B
13	CAM0_HD+	33	CAM1_D5+	53	CAM1_D0-
14	CAM0_PCLK+	34	CAM1_D4+	54	CAM1_D1-
15	GND	35	CAM1_D3+	55	CAM1_D2-
16	GND	36	CAM1_D2+	56	CAM1_D3-
17	CAM0_PCLK-	37	CAM1_D1+	57	CAM1_D4-
18	CAM0_HD-	38	CAM1_D0+	58	CAM1_D5-
19	CAM0_VD-	39	CTRL1A	59	CAM1_D6-
20	NC	40	CTRL1C	60	CAM1_D7- (MSB-)

Table 39. Pinout of CVM6/CVM9's digital video port

Connect one or two Hitachi KP-F100 digital cameras to CVM6 or CVM9 as described in *Connecting Hitachi KP-F100 Digital Cameras* on page 127. To connect Basler A113P digital cameras to CVM6 or CVM9, see *Configuring Basler A101/A101P/A113P Cameras* on page 119.

## CVM 6 and CVM9 Line Numbering

When using Cognex vision processing software, address the analog camera as camera 0. Address the digital camera attached to the cable branch labeled “Camera 1” as software camera 0, while the camera attached to cable branch “Camera 2” is software camera 1.

There is no conflict between an analog camera 0 and a digital camera 0 because you must use different video format descriptors for the different types of cameras. Think of the software camera addresses as zero-based instance numbers: there's a 0th and 1st instance of the digital camera video format descriptor and a 0th instance of the analog camera video format descriptor.

For purposes of hooking up trigger signals to a parallel I/O board, CVM6 and CVM9 cameras are have logical positions 2, 3, and 4. That is, to trigger an acquisition on the camera connected to the analog port, connect your trigger input signal to the pin that delivers signal TTL\_IN\_6. To trigger an acquisition on the first digital camera, use the pin that delivers signal TTL\_IN\_7. For the second digital camera, use the pin that delivers

signal TTL\_IN\_8. Refer to *Parallel I/O Boards* on page 43 to determine the correspondence between signal names and pin numbers for the parallel I/O board configuration you are using.

A strobe pair is the single logical unit formed by the plus and minus strobe signal lines with the same logical number. That is, strobe pair 1 consists of signal lines OPTO\_OUT1+ and OPTO\_OUT1-.

For purposes of hooking up strobes to CVM6 or CVM9, the strobe pairs have logical positions 2, 3, and 4. That is, strobe pair 2 corresponds to the analog camera port, while strobe pairs 3 and 4 correspond to digital camera ports 0 and 1. Thus, if enabled in software, an image acquisition on the analog camera port simultaneously fires the strobe connected to strobe pair 2, while an acquisition on digital camera port 0 fires the strobe connected to strobe pair 3.

**Note** When you are using the external option of the universal parallel I/O board to strobe digital cameras connected to CVM6 or CVM9, the output line TTL\_OUT\_3 does not respond unless a camera is physically plugged into digital camera port 1. Likewise, output line TTL\_OUT\_4 does not respond unless a camera is plugged into digital camera port 2. See your Cognex software documentation for the correspondence between logical line numbers and physical pins.

CVM6/9's line numbering scheme is summarized in Table 40.

<b>Camera port</b>	<b>Associated trigger line on parallel I/O board</b>	<b>Associated strobe lines on parallel I/O board</b>	<b>Cognex software address</b>
Analog	Trigger 2 (TTL_IN_6)	Strobe pair 2 (OPTO_OUT2+ and 2-)	0
Digital 1	Trigger 3 (TTL_IN_7)	Strobe pair 3 (OPTO_OUT3+ and 3-)	0
Digital 2	Trigger 4 (TTL_IN_8)	Strobe pair 4 (OPTO_OUT4+ and 4-)	1

Table 40. CVM6 and CVM9 line numbering

## CVM11 Description

CVM11 supports one or two digital line scan cameras on two acquisition channels. CVM11 also provides support for one or two incremental encoders. CVM11 supports two simultaneous image acquisitions.

CVM11 requires a minimum of 64 Mbytes of RAM on the hosting frame grabber or vision processor. When using two cameras, a minimum of 128 Mbytes of RAM is recommended.

## CVM11 Camera Support

The cameras and camera cables supported on this CVM by your Cognex software package are listed in the Supported Cameras table for your software release, found in the Cognex menu of the Windows Start -> Programs list.

**Note** The two branches of camera cables 300-0258 and 300-0323 are labeled P2 and P3. Those branches correspond to CVM11's camera channels as follows:

- P2: camera channel 0 (CAM0)
- P3: camera channel 1 (CAM1)

**Note** CVM11 does *not* supply power for connected cameras because of constraints on the amount of power that can be pulled from the PCI bus. You *must* supply external power for your line scan cameras.

## CVM11 Camera Port

CVM11's digital video input port is a high-density 60-pin Molex LFH-60 female connector carrying signals for the connection of two digital line scan cameras. The pin numbering of the camera port is shown in Figure 45.

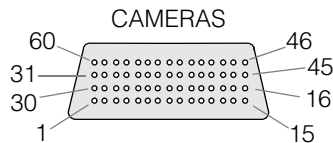

Figure 45. Pin numbering of CVM11's camera port

The pinout for the digital camera port is shown in Table 41. The signals for the two digital cameras are named beginning with CAM0 and CAM1. CVM11's camera port must be connected to a cable that splits the signals from the CVM11 into two 36-pin camera connectors, one each for CAM0 and CAM1.

Pin	Signal Name	Pin	Signal Name	Pin	Signal Name
1	CAM0_D7+ (MSB+)	21	CAM0_PRIN-	41	CAM1_GP_OUT+
2	CAM0_D6+	22	CAM0_MCLK-	42	CAM1_EXSYNC+
3	CAM0_D5+	23	CAM0_D0-	43	CAM1_LVAL+
4	CAM0_D4+	24	CAM0_D1-	44	CAM1_PCLK+
5	CAM0_D3+	25	CAM0_D2-	45	GND
6	CAM0_D2+	26	CAM0_D3-	46	GND
7	CAM0_D1+	27	CAM0_D4-	47	CAM1_PCLK-
8	CAM0_D0+	28	CAM0_D5-	48	CAM1_LVAL-
9	CAM0_MCLK+	29	CAM0_D6-	49	CAM1_EXSYNC-
10	CAM0_PRIN+	30	CAM0_D7- (MSB-)	50	CAM1_GP_OUT-
11	CAM0_GP_OUT+	31	CAM1_D7+ (MSB+)	51	CAM1_PRIN-
12	CAM0_EXSYNC+	32	CAM1_D6+	52	CAM1_MCLK-
13	CAM0_LVAL+	33	CAM1_D5+	53	CAM1_D0-
14	CAM0_PCLK+	34	CAM1_D4+	54	CAM1_D1-
15	GND	35	CAM1_D3+	55	CAM1_D2-
16	GND	36	CAM1_D2+	56	CAM1_D3-
17	CAM0_PCLK-	37	CAM1_D1+	57	CAM1_D4-
18	CAM0_LVAL-	38	CAM1_D0+	58	CAM1_D5-
19	CAM0_EXSYNC-	39	CAM1_MCLK+	59	CAM1_D6-
20	CAM0_GP_OUT-	40	CAM1_PRIN+	60	CAM1_D7- (MSB-)

Table 41. Pinout of CVM11 camera port

## CVM11 LEDs

CVM11 includes six amber LEDs along the top edge of the CVM daughtercard that light according to the conditions described in Table 42. Note that the first five LEDs show only the state of camera and encoder channel 0. Channel 1's state is not reflected in the LEDs.

LED Label	Reports on	Meaning															
MOVE	Channel 0	Illuminated when the encoder detects motion.															
DIR	Channel 0	The direction of the detected motion. Illuminated means motion in the positive (+X) direction.															
CCLK	Channel 0	Illuminated when a camera is detected on channel 0.															
ACQ1	Channel 0	These two LEDs together show the state of the image acquisition sequence.															
ACQ0	Channel 0																
		<table border="1"> <thead> <tr> <th>ACQ1</th> <th>ACQ0</th> <th>Acquisition State</th> </tr> </thead> <tbody> <tr> <td>Off</td> <td>Off</td> <td>Idle</td> </tr> <tr> <td>Off</td> <td>On</td> <td>Armed</td> </tr> <tr> <td>On</td> <td>Off</td> <td>Triggered (waiting for encoder trip count)</td> </tr> <tr> <td>On</td> <td>On</td> <td>Acquiring</td> </tr> </tbody> </table>	ACQ1	ACQ0	Acquisition State	Off	Off	Idle	Off	On	Armed	On	Off	Triggered (waiting for encoder trip count)	On	On	Acquiring
ACQ1	ACQ0	Acquisition State															
Off	Off	Idle															
Off	On	Armed															
On	Off	Triggered (waiting for encoder trip count)															
On	On	Acquiring															
DONE	Entire CVM	If illuminated, the video timing chip on CVM11 did not complete its configuration. Power cycle the hosting frame grabber or vision processor. If the condition persists, contact Cognex Technical Support.															

Table 42. CVM11 LED meanings

## CVM11 Line Numbering

When using Cognex vision processing software, address the camera connected to the cable branch labeled P2 as camera 0 (CAM0); address the camera connected to the cable branch labeled P3 as 1 (CAM1).

Image acquisition on line scan cameras is usually triggered by CVM11 in conjunction with encoder input. Encoder triggering is enabled in software.

Traditional hardware triggers and strobes are still available on CVM11, by connecting TTL signals to a parallel I/O board. A traditional hardware trigger will initiate an image acquisition, as on other CVMs, but encoder input must be supplied. Your Cognex software package supplies a software test encoder that can be used to simulate encoder input in lieu of encoder hardware.

For purposes of connecting traditional hardware trigger signals to a parallel I/O board, CVM11 cameras have logical positions 3 and 4. That is, to trigger an acquisition on the first camera (CAM0), connect your trigger input signal to the pin that delivers the trigger 3 signal (TTL\_IN\_7). To trigger an acquisition on the second camera (CAM1), use the pin that delivers the trigger 4 signal (TTL\_IN\_8). Refer to *Parallel I/O Boards* on page 43 to determine the correspondence between signal names and pin numbers for the parallel I/O board configuration you are using.

A strobe light can be used with line scan cameras, but will not be useful unless the period of the strobe pulse is wide enough, and timed to remain on during all the individual line acquisitions that make up a line scan camera's image.

A strobe pair is the single logical unit formed by the plus and minus strobe signal lines with the same logical number. That is, strobe pair 1 consists of signal lines OPTO\_OUT1+ and OPTO\_OUT1-.

For purposes of hooking up strobes to CVM11, the pairs of strobe signals on the parallel I/O board have logical positions 3 and 4. That is, the strobe pair in logical position 3 corresponds to the CAM0 camera, while strobe pair 4 corresponds to the CAM1 camera. Thus, if strobing has been enabled in software, an image acquisition on the CAM0 camera simultaneously fires the strobe connected to strobe pair 3, while an acquisition on the CAM1 camera fires the strobe connected to strobe pair 4.

CVM11's line numbering scheme is summarized in Table 43.

<b>Camera</b>	<b>Associated trigger line on parallel I/O board</b>	<b>Associated strobe lines on parallel I/O board</b>	<b>Cognex software address</b>
CAM0	Trigger 3 (TTL_IN_7)	Strobe pair 3 (OPTO_OUT3+ and 3-)	0
CAM1	Trigger 4 (TTL_IN_8)	Strobe pair 4 (OPTO_OUT4+ and 4-)	1

*Table 43. CVM11 Camera Numbering*

## Using Encoders

An encoder is an electro-mechanical transducer that converts rotary or linear motion into electrical signals. Encoders are used to determine speed, velocity, distance, position, or direction. Examples of encoder types vary widely, and include equipment as different as an airplane's altimeter or a computer's trackball.

When used with a line scan camera, an encoder provides a mechanism to keep track of the position and direction of the scene under the camera lens. Line scan cameras capture one row of pixels at a time, and build up an image by combining hundreds of rows into an image. To insure that the image is uniform and not stretched or compressed, the motion of the scene under the lens must be uniform, and must occur at a known rate.

## Encoders and CVM11

CVM11 uses encoder input to:

- Count the number of lines that have passed under the camera lens, so that it knows when to start and stop image acquisition. This is encoder-triggered image acquisition.
- Monitor the uniformity of motion of the scene under the lens.
- Detect motion changes (a direction change, or a halt).

CVM11 cannot acquire an image from a line scan camera without encoder input. It is the encoder input that CVM11 uses to calculate the number of lines that comprise a single image.

Cognex software provides a software-based test encoder that can be used to simulate encoder input for testing and setup, in lieu of a hardware encoder.

## Encoder Characteristics

The design of your vision system will determine the most appropriate encoder type for your system. In general, the encoder type most useful for the machine vision component of a factory automation system is likely to be a *dual-channel quadrature incremental rotary encoder*. The important characteristics of this encoder type are described in the following points:

- A rotary encoder measures the number of revolutions of a spinning shaft or tube. You can attach a measuring wheel to the shaft, and place the wheel against a conveyor system to translate the conveyor's linear motion into the encoder's rotary measurements. A rotary encoder's output is specified in cycles per revolution (CPR).
- An incremental encoder produces a series of cyclically repeating pulses. One full revolution of a rotary incremental encoder produces the same number of pulses every time. An incremental encoder's important output is the number of cycles produced, not the position of the encoder shaft. (By contrast, an absolute encoder produces a unique x-y value (perhaps a voltage or a binary count) for each mechanical position.)

- A dual-channel encoder supplies two sets of incremental output data. One of the two encoder channels generally leads the other by 90 degrees, which puts the two channels in quadrature relationship to each other. By convention, two encoder channels are referred to as channel A and B.
- A quadrature dual-channel encoder is used for measuring bidirectional motion. Because the two channels are in quadrature relationship (90 degree phase offset), the system can monitor the phase relationship between the two channels to determine the direction of motion.
- Another advantage of quadrature encoders is that the resolution of the measurement is four times the actual shaft revolution. For example, a quadrature encoder with a CPR of 250 provides a resolution of 1,000 counts per shaft revolution.
- Incremental encoders might provide an index pulse in addition to their A and B channel output. The index pulse provides an absolute reference point for the encoder's spin, referred to as a the center, home, or reset position of the encoder. By convention, the index pulse is referred to as the Z channel.

## Matching Encoders to CVM11

The CVM11 encoder input circuitry is RS-422 differential and conforms to the following standards: ANSI EIA/TIA-422-B, EIA/TIA-423-B, ITU V.10, and ITU V.11. To match this input type, specify an encoder with line driver output circuitry and differential ABZC output wiring layout. If your application does not use the index (Z) channel, then ABC output wiring will also work.

You can connect the output of your encoder to the CVM11 encoder port by constructing your own cable, or by using one of the Cognex encoder cables described in *CVM11 Encoder Cables* on page 109. This manual uses the symbols + and – to distinguish the two halves of an encoder channel's differential signal pair. Your encoder manufacturer may use a different notation, as shown in Table 44.

<b>CVM11 Encoder Port</b>	<b>Corresponds to encoder vendor documentation ...</b>		
<b>A+</b>	A	A	A
<b>A–</b>	$\bar{A}$	A'	A <sub>ret</sub>
<b>B+</b>	B	B	B
<b>B–</b>	$\bar{B}$	B'	B <sub>ret</sub>
<b>Z+</b>	Z	Z	Z
<b>Z–</b>	$\bar{Z}$	Z'	Z <sub>ret</sub>

Table 44. Encoder channel notation

If your encoder is a single channel type, connect its output to the A+ and A– pins of the CVM11 encoder port.

If your application will use encoder-triggered image acquisitions, then you must set up your Cognex software package to be aware of the characteristics of your encoder hardware. Your encoder vendor’s documentation will provide your encoder’s basic characteristics, such as the number of encoder cycles per revolution. Your software package’s documentation includes formulas and examples for translating the encoder’s cycles per revolution into the number of encoder steps for each line of image acquired by the line scan camera.

### Relationship Between Encoder and Camera Channels

You can use one encoder to supply input to two line scan cameras, or one encoder per camera. An encoder connected to encoder channel EN\_0 can supply input to camera channel CAM0 or CAM1, or both. An encoder connected to channel EN\_1 can supply input only to camera channel CAM1.

When powered on, CVM11 defaults to using encoder channel EN\_0 for encoder input for both camera channels. To use a second encoder on channel EN\_1, you must associate EN\_1 with CAM1 using software commands.

The relationship between encoder channels and camera channels is summarized in Table 45.

Encoder channel	Can supply input to CAM0	Can supply input to CAM1
EN_0	Yes (default)	Yes (default)
EN_1	No	Yes (switched in software)

Table 45. Encoder and camera channel relationships

### CVM11 Encoder Port

CVM11 includes a port for connecting one or two incremental encoders. Image acquisition can be triggered by encoder input at a user-specified trip point. The encoder port is an HD-15F; pin numbering for the encoder port is shown in Figure 46.

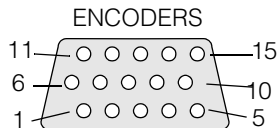

Figure 46. Pin numbering for CVM11’s encoder port

**Caution**

*The HD-15F encoder port on CVM11 resembles an industry-standard VGA monitor connector, but the pins are wired differently. Do not connect this port to a monitor or you may damage your CVM or your monitor.*

There are two independent encoder sections in CVM11. You can use one encoder or two, as described in *Relationship Between Encoder and Camera Channels* on page 108. Each encoder section accepts up to three differential RS-422 signals, which are the channel A, B, and index (Z) signals, as described in *Using Encoders* on page 105.

Connect your encoder equipment to CVM11 through the encoder port, using the pinout in Table 46 as a guide. The EN\_0 signals correspond to the encoder associated with camera port 0; EN\_1 signals are for the encoder associated with camera port 1.

Pin	Signal Name	Pin	Signal Name	Pin	Signal Name
1	EN_0_CHA+	6	EN_0_CHA-	11	GND
2	EN_0_CHB+	7	EN_0_CHB-	12	GND
3	EN_0_CHZ+	8	EN_0_CHZ-	13	NC (Reserved VCC)
4	EN_1_CHA+	9	EN_1_CHA-	14	EN_1_CHZ+
5	EN_1_CHB+	10	EN_1_CHB-	15	EN_1_CHZ-

Table 46. Pinout of CVM11 encoder port

## CVM11 Encoder Cables

Cognex provides two cables for connecting your encoder equipment to the encoder port on CVM11, as described in Table 47.

Encoders	Encoder channels	Cognex cable part number
One encoder channel	EN_0 only	300-0332
Two encoder channels	EN_0 and EN_1	300-0333

Table 47. Cognex encoder cables

Both encoder cables have an HD-15M connector on one end; connect this end to the encoder port on CVM11.

Encoder equipment varies greatly, so the encoder cables are not intended to match a particular brand or model of encoder. Instead, the cables terminate in one or two 6-pin, two-row Molex Mini-Fit connectors (Molex 5557d series). This connector mates to matching connectors from several vendors, including the following examples. Consult vendor catalogs for the latest information.

- Molex 5559d series receptacle housing (for example, Molex P/N 39-01-3063) with six 5558 series pins
- AMP P/N 794954-6 receptacle housing with six P/N 794955 pins
- AMP P/N 1586019-6 receptacle housing with six P/N 794955 pins

Construct cables to go from your encoder equipment to the Cognex encoder cable (300-0332), using one of the mating connectors, and using the pin numbering in Figure 47 and the pinout in Table 48 as guides.

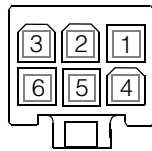

Molex 5557d connector, Cognex cable 300-0332  
Front view, showing female pin numbering

Figure 47. Pin numbering of Cognex encoder cable (300-0332) Molex connector

Table 48 shows the encoder signals on the Molex connector shown above, where *n* is encoder channel 0 or 1.

Pin	Signal Name	Pin	Signal Name	Pin	Signal Name
1	EN_ <i>n</i> _CHA+	2	EN_ <i>n</i> _CHZ+	3	EN_ <i>n</i> _CHB+
4	EN_ <i>n</i> _CHA-	5	EN_ <i>n</i> _CHZ-	6	EN_ <i>n</i> _CHB-

Table 48. Pinout of Molex 5557d connector

The cameras and camera cables supported on this CVM by your Cognex software package are listed in the Supported Cameras table for your software release, found in the Cognex menu of the Windows Start -> Programs list.

## Connecting Cameras

This section discusses how to connect cameras to Cognex frame grabbers. Instructions are included for cameras that require special handling.

You may purchase cameras through Cognex, or you may use your own approved cameras. Failing to use a Cognex-approved camera may affect the warranty coverage on your frame grabber.

For most CVMs, monochrome analog cameras are not connected directly to the CVM. Instead, a required camera breakout box or camera breakout cable must be connected to the CVM. The breakout box or cable splits the CVM's camera connector into one or more camera ports, usually using a Hirose connector. You then connect your camera cable to one of the camera ports on the breakout box or cable.

## Cognex Camera Cables

Your Cognex software package includes a Supported Cameras table as part of the documentation for each software release. The Supported Cameras table also documents the Cognex camera cable and part number for each supported camera.

Find the Supported Cameras table in the Cognex menu of the Windows Start -> Programs menu.

**Note** You must use Cognex camera cables to connect your camera to the CVM's breakout box or breakout cable. Using non-Cognex camera cables could damage your vision system, your camera, or both.

## Optional Camera Lenses

Cognex offers a lens kit (P/N 800-1000), which includes five lenses (8.5 mm, 12.5 mm, 16 mm, 25 mm, and 50 mm F2.8 macro), a C-mount adapter, and an extension tube set.

Cognex also offers a variety of camera lenses that you can order individually, including all the lenses in the lens kit, plus 50 mm, 75 mm, and 135 mm lenses. You can also separately order the C-mount adapter, a 2X extender lens, or an extension tube set.

## Attaching Cameras to the CVM Breakout Box

The camera breakout box is used with CVM1. It attaches to the DB-26F connector on the front panel of the CVM, and provides four Hirose HR10A receptacles for analog video cameras. The breakout box attaches securely to the CVM's back panel connector using captive screws on the breakout box. Figure 48 shows the camera breakout box.

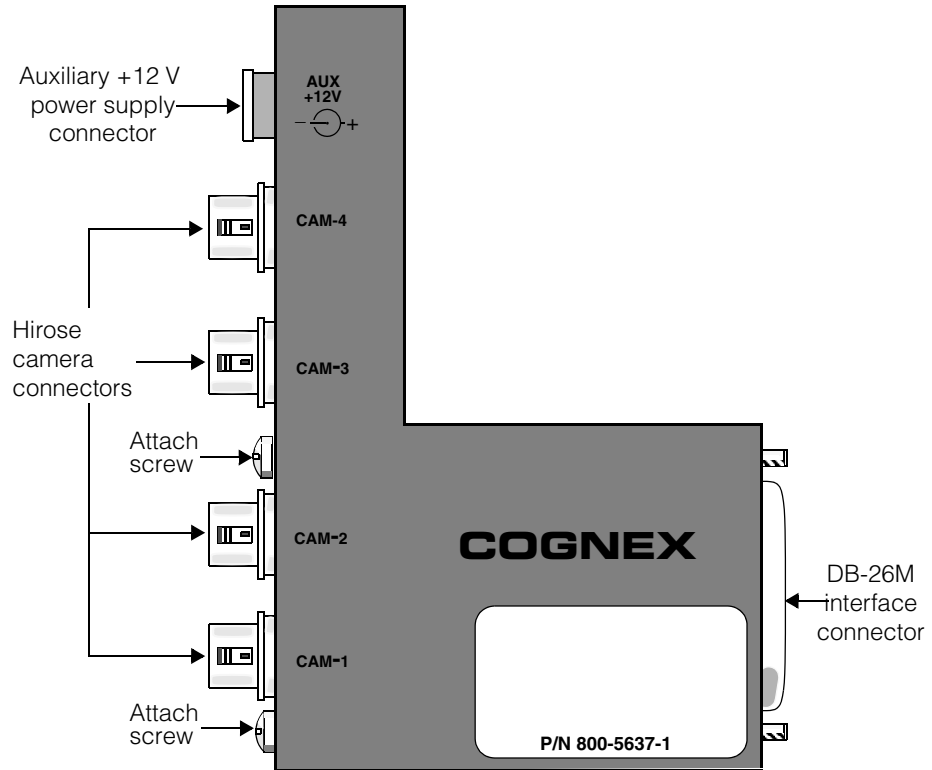

Figure 48. Breakout box for use with CVM1

**Caution**

*Cognex breakout boxes are not interchangeable. The camera breakout box you use must have the 800-5637-n part number, where n is 1, 2, or 3. Using an earlier model breakout box could damage your cameras, your vision system, or both.*

To attach the camera breakout box, follow these steps:

1. With power off to your PC and camera(s), plug the camera breakout box into the DB-26F connector on the back of the CVM. Secure the breakout box to the connector using a slotted screwdriver. The connection should be snug; do not overtighten.
2. For the first camera, use the appropriate Hirose camera cable to connect the DC IN/SYNC connector on the camera to the CAM 1 connector on the camera breakout box. Camera cable part numbers are listed in the CVM description section of this chapter.
3. To connect additional cameras, use the appropriate Hirose camera cable to connect the DC IN/SYNC connector on each camera to one of the open connectors on the camera breakout box.

## Auxiliary Power Supply for Breakout Box

The total +12 V power draw from cameras attached to CVMs must not exceed 750 mA. If your application requires more power, you must use a +12 V power adapter to supply the additional power. The adapter plugs into the auxiliary power supply socket at the top of the camera breakout box.

For example, the Pulnix TM-9701 camera draws 500 mA. If your application requires two TM-9701 cameras, the total current draw would be 1 A, which exceeds the 750 mA maximum. In this case, use the +12 V power adapter.

Use the optional Cognex power adapter (P/N 158-0015) or use an adapter that has the characteristics described in this section. Figure 49 shows the optional power adapter.

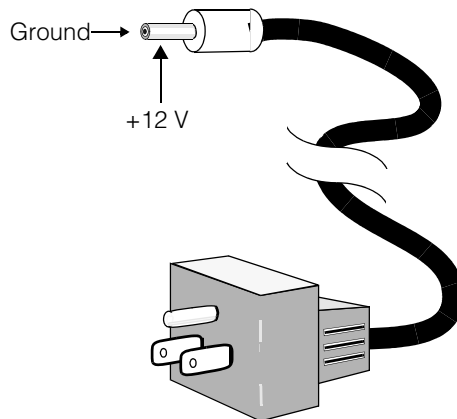

Figure 49. External power supply for breakout box

The Cognex breakout box external power adaptor (P/N 158-0015) has the following characteristics.

- 2.1 mm x 5.5 mm coaxial male jack that is center-negative (center ground)
- +12 VDC  $\pm$ 5% regulated output, 2.5 A
- Accepts 90 to 240 VAC input from a grounded wall plug (American or European)

**Caution**

*Always plug this power adaptor into the breakout box first and then into an AC wall plug. Because the 2.5 mm jack has positive voltage on the outside of the connector, if you plug the adapter into an AC wall plug first, you may contact a metal surface with the positive voltage on the outside of the 2.5 mm jack, causing a spark.*

## Attaching the Camera Breakout Cable

As an alternative to the camera breakout box, you can use a four-camera breakout cable, P/N 300-0232.

To attach the camera breakout cable, follow these steps:

1. With power off to your PC and camera(s), plug the camera breakout cable into the DB-26F connector on the back of the CVM. Secure the breakout cable to the connector.
2. For the first camera, use the appropriate Hirose camera cable to connect the DC IN/SYNC connector on the camera to the breakout cable branch labeled CAM 1. Camera cable part numbers are listed in the CVM description section of this chapter.
3. To connect additional cameras, use the appropriate Hirose camera cable to connect the DC IN/SYNC connector on each camera to one of the open connectors on the camera breakout cable.

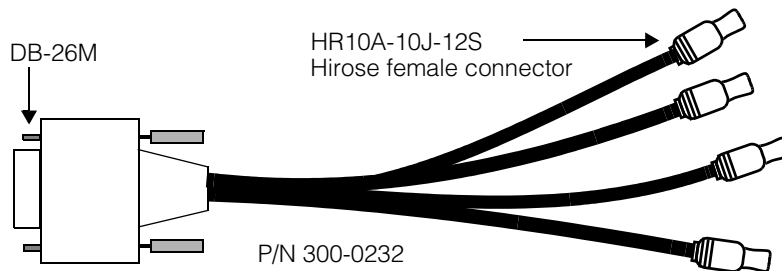

Figure 50. Camera breakout cable, P/N 300-0232

## Auxiliary Power Supply for Breakout Cable

If your application uses two or more cameras with large current requirements (such as the Pulnix TM-9701 camera), then you must supply external +12 V power to make sure the current draw on the CVM does not exceed 750 mA. This requirement is described in *Auxiliary Power Supply for Breakout Box* on page 113.

In this case, use the alternative breakout cable, P/N 300-0230. This version of the breakout cable has four Hirose connector branches plus a fifth cable branch with a 5-pin DIN female connector to connect an external power supply to provide the extra +12 V power.

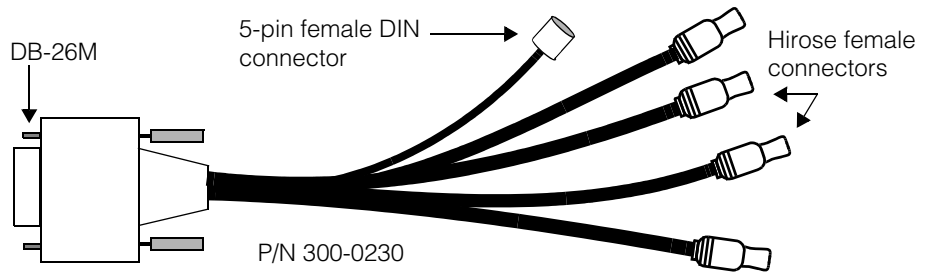

Figure 51. Camera breakout cable with power input, P/N 300-0230

**Note**

Unlike the 800-5637-1 breakout box (where using a power supply is optional), you *must* connect a power supply when using this breakout cable.

Use the Cognex power adapter for this cable (P/N 800-5728-1), or use an adapter that has the characteristics described in this section. The pin numbering for the 5-pin female DIN connector is shown in Figure 52, while the pinout for this connector is shown in Table 49.

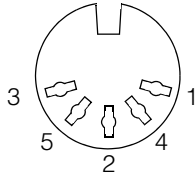

Figure 52. Pin numbering for DIN power connector on cable 300-0230

Pin on DIN connector	Signal
1	GND
2	NC
3	NC
4	NC
5	+12V

Table 49. Pinout for power input DIN connector on cable 300-0230

## Hirose Connector Pinout

The Cognex breakout box and breakout cables use Hirose HR10A 12-pin connectors, which may also be used by analog cameras and camera cables. Hirose HR10A connectors are either plugs, jacks, or receptacles. Jacks and receptacles both receive plugs. Receptacles, plugs, and jacks can all be male or female. The pinout of an HR10A connector does not depend on its gender, but on whether it is a plug on the one hand or a receptacle or jack on the other.

Hirose 12-pin HR10A connectors have part numbers of the form HR10A-10x-12y, where:

- x is R for receptacle, P for plug, or J for jack
- y is P for male or S for female

Figure 53 shows the pin numbering for HR10A-10R-12y receptacles and HR10A-10J-12y jacks, whether male or female. The DC IN/SYNC port on the back of most supported analog cameras is an example of an HR10A-10R-12P male receptacle.

The connector on the Cognex camera breakout box is an HR10A-10R-12S female receptacle, while the connectors at the end of the Cognex camera breakout cables are HR10A-10J-12S female jacks.

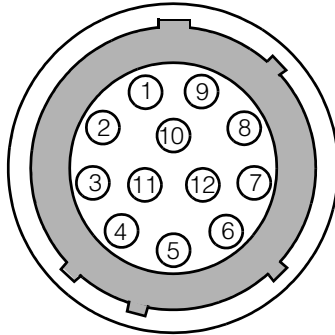

Figure 53. Hirose HR10A receptacle or jack pin numbering

Figure 54 shows the pin numbering for HR10A-10P-12y plugs, whether male or female:

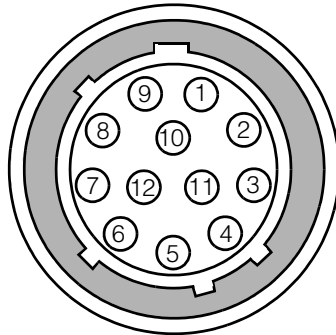

Figure 54. Hirose HR10A plug pin numbering

Table 50 shows the pinout for all Hirose HR10A 12-pin connectors, whether receptacle, plug, or jack.

Pin	Signal	Notes
1	Ground	
2	+12 VDC	
3	Video ground	
4	Video signal	

Table 50. Hirose HR10A 12-pin connector pinout

Pin	Signal	Notes
5	HD ground	
6	HD (horizontal drive) signal	
7	VD (vertical drive) signal	
8	Camera control 2	Pins 8, 9, 10, and 11 might be used by different cameras for different purposes. The Cognex cable for each camera maps these pins correctly for that camera.
9	No connection	
10	Camera control 1	
11	No connection	Pin 11 is defined as a second +12V line in some implementations, but the Cognex breakout box and breakout cables do not pass +12V on this line.
12	VD ground	

*Table 50. Hirose HR10A 12-pin connector pinout*

# Configuring Cameras

Some supported cameras need switch settings or special cable configurations when used with Cognex software, as described in the following sections.

## Configuring Basler A101/A101P/A113P Cameras

Cognex vision boards with CVM9 support the Basler A101 or A101P digital camera, whose former designation was the A113P.

The Basler A101/A101P camera is configured by means of a serial port at the back of the camera. You can obtain the Basler Classic Camera Configuration Tool from the CD-ROM provided by Basler or from <http://www.baslerweb.com>. Install the tool and use a serial cable to connect the host PC to the camera.

To run the Basler configuration tool, invoke **Start -> Programs -> Basler -> Camera Config Tool**. As the application starts, it displays “Responding” in the lower right part of its window to indicate that it is communicating with the camera. The initial display for the A101P/A113P camera is shown in Figure 55.



Figure 55. Start screen for A101 in Basler camera configuration tool

You need to modify only two factory settings to ensure that the camera works correctly with Cognex software.

1. Select the **Exposure** tab and set the mode to **Level**.

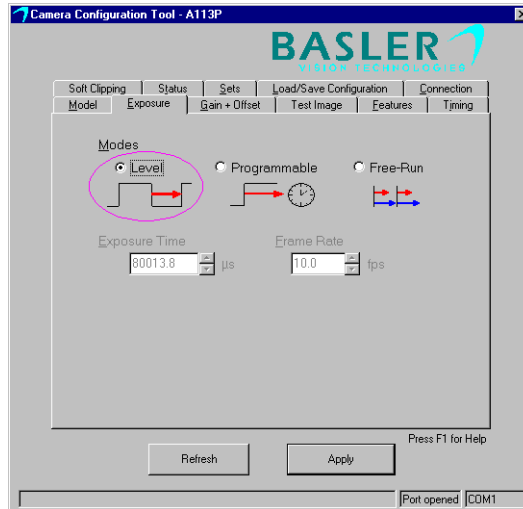

2. Click **Apply**.
3. Select the **Timing** tab and select **Fixed Timing**.



4. Click **Apply**.
5. To save your changes to the camera, select the **Sets** tab.

- Click the down-pointing arrow between the **Work set** and **User set**.
- Click **Apply**

## Configuring Basler L103-2k Cameras

Cognex vision boards with CVM11 may support the Basler L103-2k line scan camera.

The L103-2k is configured by means of a serial port at the back of the camera. Obtain the Basler Classic Camera Configuration Tool from the CD-ROM provided by Basler or from <http://www.basler-vc.com>. Install the tool and use a null-modem serial cable to connect the host PC to the camera as described in Basler's documentation.

To run the Basler configuration tool, invoke **Start -> Programs -> Basler -> Camera Config Tool**. As the application starts, it displays "Responding" in the lower right part of its window to indicate that it is communicating with the camera. The initial display for the L103-2k camera is shown in Figure 56.



Figure 56. Start screen for L103-2k in Basler camera configuration tool

You need to modify only one factory setting to ensure that the L103-2k camera works correctly with Cognex software.

1. Select the **Exposure** tab and set the mode to **Level-controlled**.

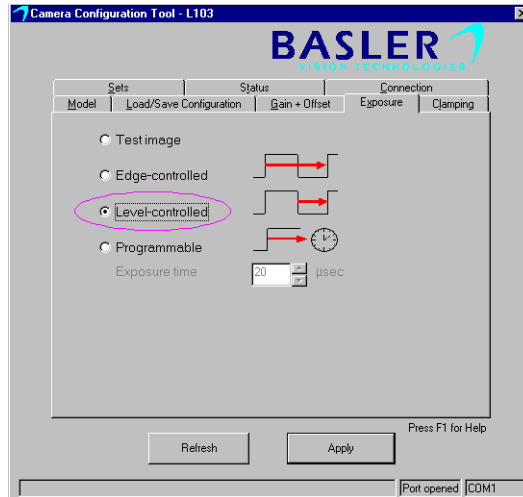

2. Click **Apply**.
3. To save your changes to the camera, select the **Sets** tab.
  - Click the down-pointing arrow between the **Work set** and **User set**.
  - Click **Apply**

## Connecting and Configuring Basler L401k Cameras

The Basler L401k line scan camera uses the Camera Link protocol, so you must use the Basler k-BIC camera interface box to connect an L401k to CVM11. The k-BIC converts the camera's Camera Link LVDS signals to the RS-644 LVDS signals expected by CVM11.

Use a standard Camera Link cable to connect the L401k to the k-BIC. The Camera Link cable has a 26-pin MDR connector on each end. Connect either end of the cable to the L401k's MDR port, and the other end to the k-BIC's MDR port.

The Basler L401k is configured by means of a serial port on the k-BIC interface box. Obtain the Basler Camera Configuration Tool Plus (CCT+) from the CD-ROM provided by Basler or from <http://www.basler-vc.com>. Install the tool and use a null-modem serial cable to connect the host PC to the k-BIC as described in Basler's documentation.

To run the Basler CCT+ configuration tool, invoke **Start -> Programs -> Basler Vision Technologies-> CCT+ -> CCT+**.

The factory default settings are sufficient for use with CVM11, with two exceptions. Follow these steps:

1. Start CCT+. From the drop down list just below the menu bar, select the PC serial port that you connected to the k-BIC.
2. Open the + sign next to **Output Mode**. In the **Video Data Output Mode** field, select “Single 8 Bit”.
3. Open the + sign next to **Exposure**. In the **Exposure Time Control Mode** field, select “ExSync, level-controlled”.
4. Open the + sign next to **User Set Files**. Select one of the user set file names provided in the **File Name Select** drop down list, then use the **Create** and **Activate** features as described in the CCT+ **Parameter Description** window.

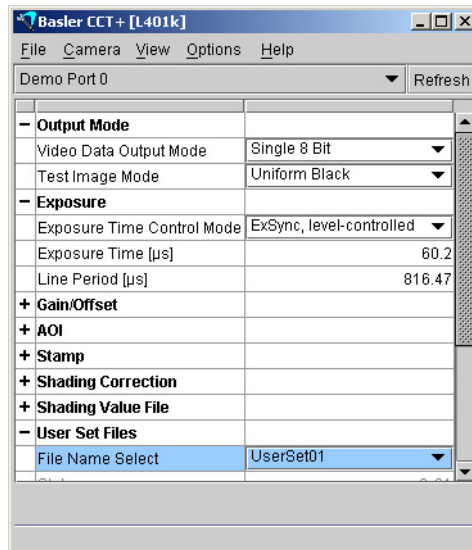

## Connecting Cognex CVC-1000 Cameras

The Cognex CVC-1000 high-performance camera connects to a CVM4 module. The CVC-1000 has no switches or jumpers; all configuration is controlled by software. The CVC-1000 always operates with electronic shutter control.

There are two breakout cables available for CVM4: the single-camera breakout cable (Cognex P/N 300-0224) and the four-camera breakout cable (Cognex P/N 300-0220). Connect the 60-pin end of your breakout cable to CVM4; connect the breakout cable's HD-15F connector to a CVC-1000 camera cable.

The CVC-1000 has a single 16-pin male Hirose connector on its back panel. The Cognex camera cable for the CVC-1000 is part number 300-0223, and has an HD-15M connector on one end and a female 16-pin Hirose connector on the camera end. Connect the cable's Hirose connector to the CVC-1000 camera; connect the cable's HD-15M end to a breakout cable.

**Caution**

*The HD-15M connector on the CVC-1000 camera cable resembles the industry-standard VGA monitor connector, but the pins are wired differently. Do not connect this cable to a monitor or you may damage your CVC-1000 or your monitor.*

The CVC-1000 camera connects lenses with a standard C-mount interface. You can use the lenses described in *Optional Camera Lenses* on page 111.

## CVC-1000 Usage Notes

Keep in mind the following points when using a CVC-1000 camera with CVM4:

- An attempt to acquire a camera image may hang your application unless a CVC-1000 camera is physically connected to the CVM4. The CVC-1000 camera provides signal and timing information to the CVM4. In the absence of a CVC-1000 camera, the CVM4 cannot resolve certain timing issues and hangs, waiting for input from the camera.
- When connecting more than one CVC-1000 camera, you must add cameras in numerical order as shown on the branch labels of the four-camera breakout cable. That is, connect the first camera to the branch labeled "Camera 1," then connect the second camera to the branch labeled "Camera 2." Do not skip a camera number branch when connecting cameras.

## CVC-1000 Specifications

Table 51 lists the design specifications for the Cognex CVC-1000 camera.

Function	Parameter	Specification
Sensor	Type	1/3 inch Interline Transfer Progressive Scan CCD
	Total elements	659 (H) x 494 (V)
	Cell size	7.4 x 7.4 $\mu\text{m}$
	Horizontal frequency	24.5454 MHz
	Active elements	640 (H) x 480 (V)
Optical	Horizontal resolution	500 TV lines
	IR Filter	None (dummy glass)
	Gamma	Y = 1 (none)
	Sensitivity	400 lux (f4.0)
	Minimum illumination	1.0 lux (f1.4)
Mechanical	Lens mount	C-Mount
	Flange back	17.526 mm
	Package size	38 x 29 x 77 mm
	Weight	130 grams
Reliability	Operating temperature	-5 to +45 degrees Centigrade
	Storage temperature	-25 to +60 degrees Centigrade
	Operating humidity	20% to 80% non-condensing
	Storage humidity	20% to 95% non-condensing
	Vibration resistance	10 G in X, Y and Z directions
	Shock resistance	70 G

Table 51. CVC-1000 specifications

Function	Parameter	Specification
Regulations	FCC	Class B
	CE	EN50081-2, EN50082-1
	UL	UL1492
Power	Requirements	12 VDC $\pm$ 5%
	Consumption	2.0 Watts $\pm$ 0.2

Table 51. CVC-1000 specifications

## CVC-1000 Video Signal Timing

CVM4 supports video acquisition signal timings appropriate for the Cognex CVC-1000 camera. The CVC-1000 camera follows neither the RS-170 nor CCIR video timing standards, instead offering its own high-speed video signal timing format. Table 52 shows the video signal specifications for the Cognex CVC-1000 camera when used with CVM4.

Parameter	Specification
Format	Cognex proprietary
Digital control and clock	RS-644 (Low voltage differential signaling)
Video	1.0 Vp-p DC-coupled into 75 Ohms
Electronic shutter	50 $\mu$ s to 65 ms
S/N ratio	55 dB minimum
Gain	0 dB fixed
Jitter	Not measurable. (A/D converter clock derived directly from CCD clock)
Vertical frequency	60 Hz

Table 52. CVC-1000 video signal timing

## Connecting Dalsa Spyder Line Scan Cameras

The Dalsa Spyder series of digital line scan cameras includes the SP-13 and SP-14 models, both of which can be used with the Cognex CVM11 video module. Both camera models have the same LVDS video signal connector and accept the same signal cables. The two models differ in the voltage requirements of the power supplied to the camera.

**Note** You must supply camera power and the appropriate camera power cable for your Dalsa Spyder camera. Cognex cables for these cameras contains video signals only.

The Dalsa Spyder SP-13 requires you to supply +5 V, -5 V, and +15 V power. The Spyder SP-14 requires you to supply +12 V power.

## Connecting Hitachi KP-F100 Digital Cameras

This section describes how to connect a member of the Hitachi KP-F100 family of digital cameras to CVM6 or CVM9. In this section, the term KP-F100 applies to all members of the camera family, except when discussing particular models in the family.

**Note** Hitachi KP-F100 cameras with serial numbers below 8100395 may require a fix by Hitachi to correct possible flaws in the trigger logic. Contact your Hitachi representative for details.

### Required Switch Settings for Hitachi KP-F100

When using a Hitachi KP-F100 digital camera, the switches on the back of the camera body must be set as shown in Table 53. After making any switch setting changes on the KP-F100, turn the camera's power off and back on.

Switch	Setting
Shutter Data - A0	Off (left)
Shutter Data - A1	Off (left)
Shutter Data - A2	Off (left)
Shutter Data - RM	On (right)
Mode	2
FD	ON

Table 53. Switch settings for Hitachi KP-F100

Figure 57 shows the supported switch settings for the Hitachi KP-F100 family.

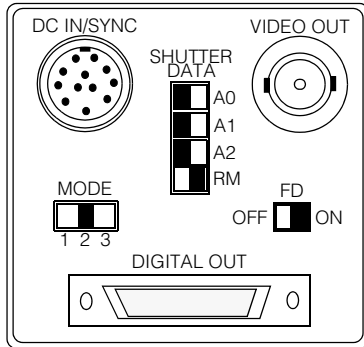

Figure 57. Switch settings diagram for Hitachi KP-F100

## Hitachi KP-F100 Usage Notes

Keep in mind the following point when using a member of the Hitachi KP-F100 digital camera family with CVM6 or CVM9.

- The KP-F100A is an updated version of the original KP-F100. The physical hookup and switch settings are identical, but the KP-F100A requires a different camera configuration format when using Cognex CVL software.
- The KP-F100B is another update to the KP-F100 family. Again, the physical hookup and switch settings are identical, but the KP-F100B requires a different camera configuration format.
- Different models of the KP-F100 family support different digital camera standards, as shown in Table 54.

Model	Digital camera standard	Supported on
KP-F100	RS-422	CVM6 only
KP-F100A	RS-644	CVM6 for existing installations, CVM9 for new installations
KP-F100B	RS-644	CVM9 only

Table 54. Models of KP-F100 family and supported CVMs

- An attempt to acquire a camera image may hang your application unless a KP-F100 camera is physically connected to the CVM. The KP-F100 camera provides signal and timing information to the CVM. In the absence of a KP-F100 camera, the CVM cannot resolve certain timing issues and hangs, waiting for input from the camera.

## Cable Connections for Hitachi KP-F100

Connecting a KP-F100 camera to CVM6 or CVM9 requires the following parts:

- Cognex CVM6/9 to HD-68F cable, Cognex P/N 300-0214
- Hitachi HD-68M to KP-F100 cable with power input, Hitachi P/N C-CG-100 (or Cognex P/N 300-0266)
- Hitachi +12V power supply, Hitachi P/N 45752C1 (or Cognex P/N 158-0020)

Cognex cable 300-0214 is a Y-cable that splits the signals from the CVM's HD-60F connector into two AIA standard HD-68F digital camera connectors, to allow the connection of one or two digital cameras to the CVM. The two HD-68F connectors are labeled Camera 1 and Camera 2.

Hitachi cable C-CG-100 has an AIA standard HD-68M digital camera connector on one end, and three cable branches on the camera end. (The AIA 68-pin connector is the same one used by wide SCSI-2 devices.) The camera end has a mini-Centronics connector, one 12-pin Hirose connector, and one three-pin power supply connector.

Follow these steps to connect the CVM to a KP-F100 camera, as illustrated in Figure 58 on page 130:

1. Connect the HD-60M connector of Cognex cable 300-0214 to the HD-60F connector on the CVM.
2. Connect the HD-68M connector of Hitachi cable C-CG-100 to one of the HD-68F connectors on cable 300-0214.
3. Connect the mini-Centronics connector on the camera end of cable C-CG-100 to the port labeled Digital Out on the back of the KP-F100 camera.
4. Connect the Hirose connector from the camera end of cable C-CG-100 into the connector labeled DC IN/SYNC on the back of the KP-F100 camera.
5. Connect the three-pin connector on the camera end of cable C-CG-100 into the three-pin cable coming from the Hitachi power supply.
6. Plug the power supply's AC adapter into an AC wall socket.

Figure 58 shows the connection between the CVM and the Hitachi KP-F100 digital camera.

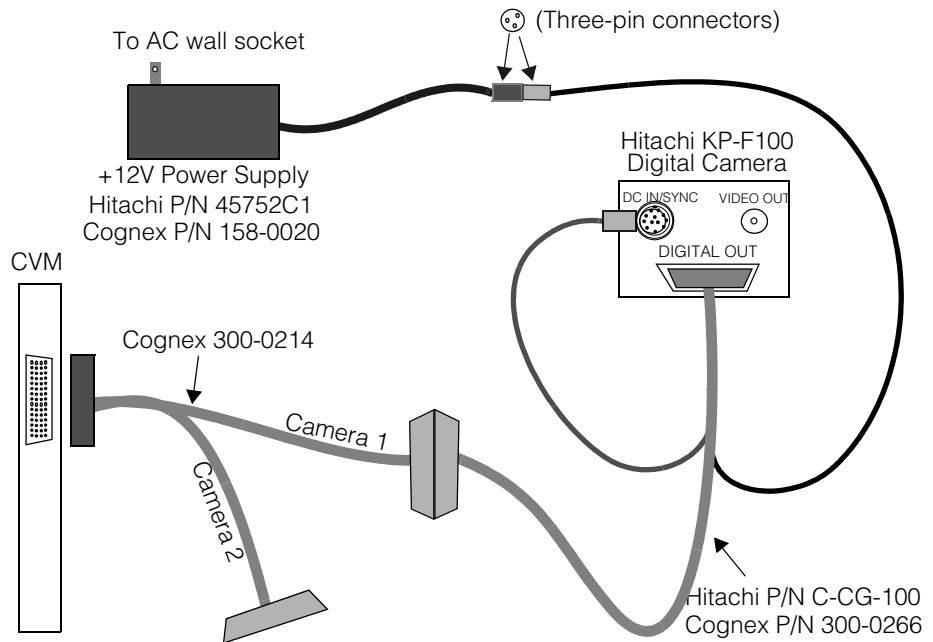

Figure 58. Connecting Hitachi KP-F100 camera to the CVM

## Power Supply for Hitachi KP-F100

The Hitachi KP-F100 digital camera requires a separate +12 V power supply. You can use Cognex P/N 158-0020, or a Hitachi power supply delivered with the camera, or you can supply your own +12 V power that meets the following specifications.

- Output voltage is +12 V DC  $\pm$  1 V
- The KP-F100 camera will use 500 mA or less
- Use a stable power supply with no ripple or noise

- The three-pin connector on Cognex cable P/N 300-0266 is a Tajimi Electronics P/N R03-JB3M. Your power supply should mate to this connector with Tajimi part number R03-P3F or R03-PB3F. Figure 59 shows the pinout for these connectors.

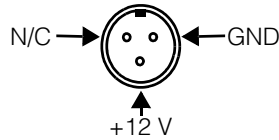

Figure 59. Pinout of Hitachi power supply connector

## Configuring JAI CV-A1-14.4 Cameras

The JAI CV-A1-14.4 is a large format, progressive scan camera. If you purchase your CV-A1-14.4 cameras from Cognex, they arrive ready to use. If you purchase your CV-A1-14.4 from a third party, you must configure the camera as described in this section.

Configure the JAI CV-A1-14.4 by connecting a serial cable between the camera and a PC running Windows. Then run JAI's Camera Control Tool (CCT), which is downloadable from JAI's web site, [www.jai.com](http://www.jai.com).

Construct a serial cable, or obtain one from JAI. One end of this cable must have a Hirose HR10A-7P-6S connector (7 mm plug, 6 pin female). This end connects to the 6-pin Hirose connector on the CV-A1-14.4. The other end of the cable should have a DB-9F or DB-25F connector, whichever matches the serial ports of the PC running the Camera Control Tool. You only need to connect TXD, RXD, and GND signal lines, using your JAI and PC documentation for pinout information. Map the CV-A1-14.4's TXD line to the RXD line on the PC's serial port, and map the camera's RXD to the PC's TXD.

1. Apply power to the CV-A1-14.4 camera.
2. Connect the serial cable to the CV-A1-14.4 camera and to an available serial port on the controlling PC.
3. Start the CV-A1 Control Tool; this displays a single toolbar with seven buttons.
4. Click the sixth button to display the **Communication** dialog.
  - a. In the **Communication Port** drop-down, select the serial port you selected in step 2, or click the **Auto** button.
  - b. Wait for the word *On-line* to show in the **Status** section.
  - c. The **Synchronize** section may show "Not Synchronized." Ignore this for now.

5. Click the first button, which opens the **Shutter and Sync Signals** dialog. Configure the fields of this dialog as follows:

Control	Setting
<b>Shutter Mode</b>	Normal
<b>Trigger Mode</b>	Pulse Width Control
<b>Trigger Polarity</b>	Active L
<b>HD Synchronous Accumulation</b>	Async
<b>Pixel Clock Out</b>	Off
<b>Partial Scan Mode</b>	Full Frame
<b>EEN/WEN</b>	WEN
<b>WEN Polarity</b>	Active L
<b>Sync Signal Output</b>	On
<b>Binning</b>	Binning OFF

6. Click the sixth button to reopen the **Communication** dialog.
  - a. Click the **Synchronize Camera** button and wait for the confirmation "Synchronized."
7. Click the fifth button to open the **Files and Camera** dialog.
  - a. Select the same *User n* setting for both **Factory and User Settings in Camera** and **Initial Data**. For example, select "User 1" for both fields.
  - b. Click the **Store Settings** button
  - c. Click the **Write to Camera** button.
  - d. Optionally, click the **Write to File** button to save the current camera settings to the file of your choice.
8. Disconnect the serial cable from the camera and PC.

The CV-A1-14.4 is now configured to work with Cognex frame grabbers. The camera will power up with these settings until you change them.

## Configuring Pulnix TM-9701 Cameras

Image acquisition using a Pulnix TM-9701 camera is only supported in non-interlaced, asynchronous, double-pulse mode. You must set the TM-9701 switches to **NON** (non-interlaced mode) and **ASY** (asynchronous mode), and you must set the rotary switch to **9** (double-pulse mode) as shown in Figure 60.

To control the TM-9701 shutter speed, you must configure the shutter speed using software controls in the Cognex software. Do not attempt to set the shutter speed using the rotary switch on the TM-9701; the rotary switch must be set to **9**.

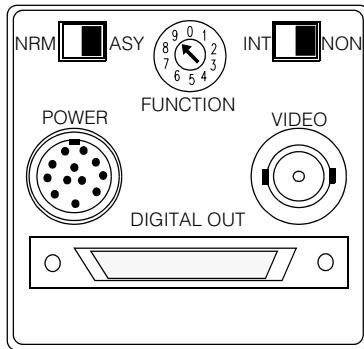

Figure 60. Pulnix TM-9701 back panel switches

## Configuring Sony XC-55 Cameras

Your Cognex software package may support the use of the Sony XC-55 and XC-55BB cameras. If you purchase your XC-55 cameras from Cognex, they arrive ready to use. If you purchase your XC-55 from a third party, you must configure the camera as shown in this section.

The XC-55/55BB, as shipped from Sony, is configured to emulate the Sony XC-75 camera. Cognex recommends instead using the XC-55/55BB in its E-DONPISHA II trigger shutter mode for best performance. Two switch settings convert the XC-55/55BB to trigger shutter mode; one switch is external, while the other is internal. Follow this procedure:

1. On the rear panel of the XC-55/55BB, locate the 1N/1I switch. Place this switch in the **1N** position.
2. Remove the cover of the camera control module. Inside the camera control module, locate the SG-257 circuit board.

On the SG-257 circuit board, locate rotary switch S2, which is in the upper right of a set of four rotary switches as you hold the camera with its top cover up and the lens mount on the right. Set this switch to the **E** position.

## Configuring Sony XC-ES50 Cameras

Your Cognex software package may support the use of the Sony XC-ES50 family of cameras, including the XC-ES50 and XC-ES50CE. If you purchase your XC-ES50 cameras from Cognex, they arrive ready to use. If you purchase your XC-ES50 from a third party, you must configure the camera as shown in this section.

Figure 61 shows the back panel of the Sony XC-ES50 camera with the switches in their factory default and rapid reset modes.

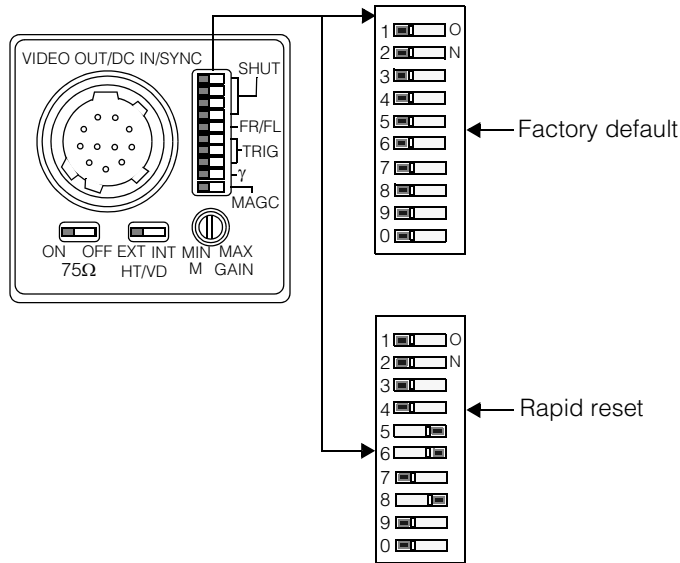

Figure 61. Sony XC-ES50 camera back panel

To configure the switches for the Sony XC-ES50 camera:

1. Configure the 10-position DIP switch as shown in Figure 61.

**Note** You can set switch 5 to ON in factory default mode to use field integration rather than frame integration (single field and half-resolution video formats only).

2. Set the manual gain switch in the fully vertical position.
3. Set the HD/VD switch to external (EXT).

- Set the 75Ω switch to ON.

## Configuring Sony XC-ST50 Cameras

Your Cognex software package may support the use of the Sony XC-ST50 family of cameras, including the XC-ST50 and XC-ST50CE. If you purchase your XC-ST50 cameras from Cognex, they arrive ready to use. If you purchase your XC-ST50 from a third party, you must configure the camera as shown in this section.

Figure 62 shows the back panel of the Sony XC-ST50 camera with the switches in their factory default and rapid reset modes.

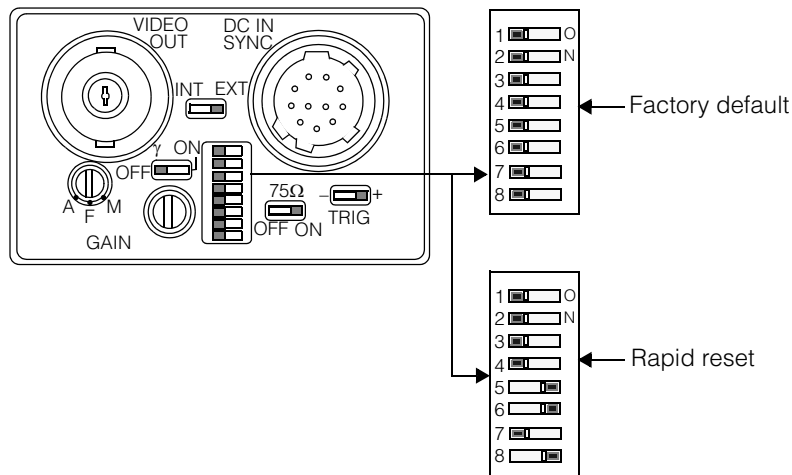

Figure 62. Sony XC-ST50 camera back panel

To configure the switch for the Sony XC-ST50 camera:

- Configure the 8-position DIP switch as shown in Figure 62.

**Note** Set switch 5 to ON in factory default mode to use field integration rather than frame integration (single field and half-resolution video formats only).

- Set gain to the “F” position.
- Set the INT EXT switch to external (EXT).
- Set TRIG to +.
- Set gamma ( $\gamma$ ) to off.
- Set the 75Ω switch to ON.

## Configuring Teli CS8531 Cameras

To use the CS8531 with CVL, two switches must be set as described in this section. One switch is on the camera's back panel, while the other is inside the camera's cover.

The Teli CS8531 camera can be connected in single-tap or dual-tap modes. Follow these steps to make the same internal switch setting for either mode.

1. Remove the cover of the camera control unit.
2. Locate the six-position switch on the topmost circuit board.
3. Place switch 3 in the ON position.
4. Place the remaining five switches in the OFF position.
5. Replace the cover.

Change the back panel's Mode switch according to the connection mode:

- Set the Mode switch to the 1/30 position when connecting in single-tap mode
- Set the Mode switch to the 1/60 position when connecting in dual-tap mode

# Camera I/O Electrical Specifications

This section describes the CVM input circuitry and signal timing that supports video input from cameras.

## Analog Video Input Circuit

The information in this section applies to CVM modules that support analog video cameras.

CAM VIDEO, the video input signal, is approximately 1 V peak to peak and is terminated with a  $75\ \Omega$  resistor to ground. Each of the analog video signals connects to the CVM as shown in Figure 63.

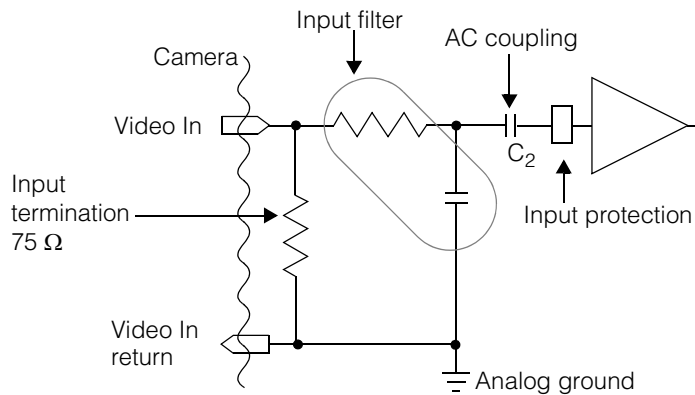

Figure 63. CVM analog video input circuit

The input filter provides noise rejection for switching and random noise above the CAM VIDEO rate. The video signal is terminated with a  $75\ \Omega$  load and is AC-coupled into the video input section. The video signal is DC-restored internally. Digitization of the input signal is relative to the black level during the blanking interval and is not affected by any DC offset that the camera may generate.

The input protection device provides over- and under-voltage protection to the A/D converter.

Figure 64 shows the totem-pole or push-pull circuit used to drive the horizontal and vertical drive signals of the CVM:

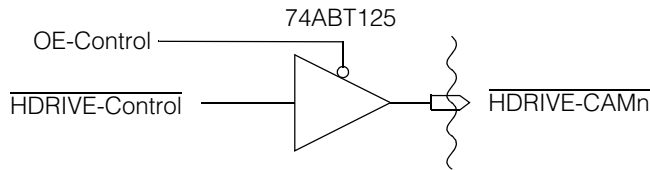

Figure 64. CVM analog camera control circuit

High-level and low-level outputs have the following TTL level characteristics:

- The guaranteed high-level output is greater than or equal to 2.7 V if the user load requirement for a TTL high level is less than or equal to 32 mA.
- The guaranteed low-level output is less than or equal to 0.8 V if the user load requirement for a TTL low level is less than or equal to 64 mA.

## Analog Video Signal Timing

CVMs support analog video acquisition signal timings for a number of different image resolutions and standards.

Table 55 shows the video timing for both RS-170 (NTSC) and CCIR (ITU-R or PAL) formats. Notice that some parameters vary slightly, depending on the width and height of the video format you use.

Signal	RS-170 (NTSC)	CCIR (PAL)
Horizontal frequency	15.75 KHz	15.625 KHz
Period	63.5 $\mu$ s	64 $\mu$ s
Active scan	41.4 $\mu$ s	51.5 $\mu$ s
Blanking	22.6 $\mu$ s	12.5 $\mu$ s
Front porch	7 $\mu$ s	2.2 $\mu$ s
Sync	4.6 $\mu$ s	4.9 $\mu$ s
Back porch	11.0 $\mu$ s	5.4 $\mu$ s
Equalizing	2.5 $\mu$ s	2.8 $\mu$ s
Horizontal drive	6.4 $\mu$ s	6.4 $\mu$ s
Vertical frequency	60 Hz	50 Hz
Period	16.7 ms	20 ms
Active	15.0 ms	16.3 ms
Equalizing	0.18 ms	0.18 ms
Sync	0.18 ms	0.18 ms
Blanking	1.7 ms	3.7 ms
Vertical drive	0.57 ms	0.57 ms
Pixel clock	12.348 MHz	14.75 MHz

Vary slightly depending on width of format

Vary slightly depending on number of rows in format

Table 55. RS-170 and CCIR video timings

## Digital Camera I/O Circuit

The information in this section applies to the CVM modules that support digital video cameras, including CVM6 and CVM9. CVMs support digital cameras in different configurations, as described in Table 32 on page 90.

For CVM6, each RS-422 digital video input signal connects to the CVM as shown in Figure 65.

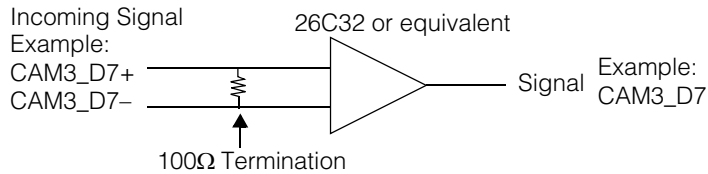

Figure 65. CVM6 digital video input circuit

For CVM9, each RS-644 digital video input signal connects to the CVM as shown in Figure 66.

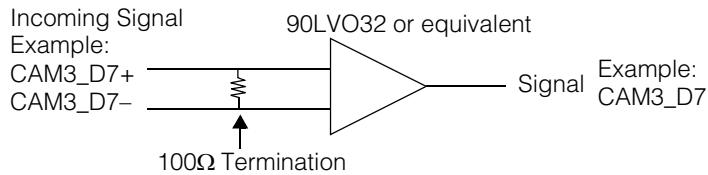

Figure 66. CVM9 digital video input circuit

Figure 67 shows the totem-pole or push-pull circuit used to drive the control signals of CVM6 and CVM9:

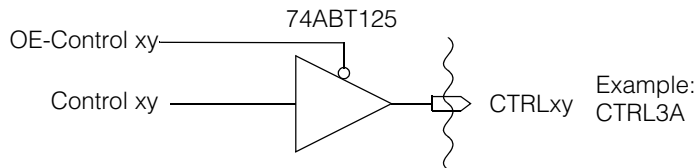

Figure 67. CVM digital camera control circuit

# Index

---

## Numerics

158-0015 113  
158-0020 129  
300-0175 21, 51  
300-0208 93, 95  
300-0214 99, 129  
300-0220 29, 96, 124  
300-0223 96, 124  
300-0224 96, 124  
300-0230 115, 116  
300-0232 114  
300-0266 129, 131  
300-0274 24, 49, 53, 54, 73, 77  
300-0287 49, 53, 54, 57, 58, 64, 65, 66,  
74, 75  
300-0288 49, 55, 57, 59, 72, 74, 75  
300-0289 49, 55, 56, 64, 67  
300-0313 93, 98  
300-0316 93, 98  
300-0332 109  
300-0333 109  
300-0344 93, 95  
800-0002-01 44  
800-0003-01 44  
800-1000 111  
800-5637 112  
800-5637-1 112, 115  
800-5712-2 76  
800-5726-1 44  
800-5726-3 45, 76, 77

800-5728-1 116

## A

A101 119  
A101P 119  
A113P  
    see Basler A101  
acquisition channels 42

## B

Basler  
    A101 119  
    A101P 119  
    A113P  
        see Basler A101  
    Camera Configuration Tool Plus 122  
    Classic Camera Configuration  
        Tool 121  
    k-BIC 122  
    L103-2k 121  
    web site 119, 121, 122  
bidirectional lines 37  
boldface  
    how used in this manual 10  
breakout box 93, 111, 112, 113  
    attaching cameras 112  
    auxiliary power supply 36  
    for monochrome cameras 28, 36  
breakout cable 29, 96, 114, 124  
bus-based video output 92

## C

camera

- auxiliary power supply 28
- Basler A101 119
- Basler A101P 119
- Basler L103-2k 121
- Cognex CVC-1000 90, 96, 123, 124, 125, 126
- Dalsa Spyder SP-14 127
- Hitachi KP-F100 127, 128, 129, 130
- Hitachi KP-F100A 128
- input signals 37
- JAI CV-A1-14.4 131
- lenses 111
- powering 28
- Pulnix TM-9701 113, 133
- Sony XC-55 133
- Sony XC-75 133
- Sony XC-ES50 134
- Sony XC-ST50 135
- camera breakout box
  - see breakout box
- Camera Configuration Tool
  - Classic 121
  - Plus 122
- camera control tool
  - JAI, for CV-A1-14.4 131
- camera numbering
  - based on CVM 42, 47
  - for CVM1 94
  - for CVM11 104
  - for CVM4, same as CVM1 97
  - for CVM6 100
  - for CVM9 100
- CameraLink LVDS 122
- cameras supported
  - on CVM11 102
  - on CVM4 96
- caution
  - 5 volt only 36
  - analog camera port resembles VGA port 99
  - breakout boxes not interchangeable 112
  - cables for use with newer cameras only 93, 98
  - CVC-1000 cable connector resembles VGA 124
  - encoder port resembles VGA port 109
  - ESD warning 18
  - must use Cognex cables 96
  - power adapter has live voltage 114
  - same ground potential with external I/O module 77
- CCIR camera
  - and hardware triggering 41
- CCT 131
- CCT+ 122
- Cognex offices 11
- Cognex video module
  - defined 32
- compliance
  - PCI 2.1 15
- connecting
  - analog cameras 111
  - CVC-1000 Camera 123
  - digital camera 127
  - Pulnix TM-9701 camera 133
  - Sony XC-55 camera 133
  - Sony XC-ES50 camera family 134
  - Sony XC-ST50 camera family 135
- connector
  - 15-pin on cable 300-0288 55
  - 15-pin on parallel I/O board 50, 54
  - 2.5 mm on cable power supply 114
  - 26-pin on cable 300-0274 54, 77
  - 26-pin on external I/O module 24
  - 26-pin on parallel I/O board 22, 23, 24, 50, 52, 77
  - 40-pin input on ISA I/O board 24
  - 40-pin on parallel I/O board 21, 50, 52
  - 40-pin parallel I/O on MVS-8120 21, 25, 37
  - camera, on CVM1 93

CAMn on breakout box 113  
 DB-26F camera, on CVM 112, 113, 114  
 DB-26F camera, on CVM1 28, 93, 94  
 DB-26M on breakout box 112  
 DC IN/SYNC 113, 114  
 DIN-5 on breakout cable 115, 116  
 external power on parallel I/O board 21, 50, 51  
 figure showing placement of 17  
 Hirose 111, 115, 116, 117  
 on faceplate of OPTO/TTL I/O board 88  
 on faceplate of TTL I/O board 87  
 screw terminal 22, 23, 25, 30  
 CV-A1-14.4 131  
 CVC-1000 camera 90, 96, 123, 124, 125, 126  
 CVL 128  
 CVM  
   defined 32, 90  
 CVM descriptions  
   CVM1 93  
   CVM11 102  
   CVM4 96  
   CVM6 98  
   CVM9 98  
 CVM11  
   encoder cables 109

## D

Dalsa Spyder  
   SP-14 127  
 DB-26F connector 93  
 DC IN/SYNC connector 113, 114  
 digital camera  
   connecting 127  
 DirectX 15

disable PCI slot 28  
 display adapters  
   recommended 15  
 DMA transfers  
   over PCI bus 14

## E

E-DONPISHA mode 133  
 electromagnetic  
   compatibility standard 35  
   emissions standard 35  
 encoder cables 109  
 Encoder port  
   on CVM11 108

## F

factory default  
   settings for Sony XC-ES50 134  
   settings for Sony XC-ST50 135  
 fuse  
   for light control lines 63

## G

general I/O lines 37

## H

hardware triggering 41  
 Hirose 112, 117  
   connector for JAI CV-A1-14.4 serial control 131  
   pin numbering 116, 117  
 Hitachi

KP-F100 127, 128, 129, 130  
KP-F100A 128

## I

input video  
    provided by CVM 32

inputs  
    TTL 32

ISA-based board  
    potential placement conflict with 20,  
    51

italics  
    how used in this manual 10

## J

JAI  
    camera control tool 131  
    CV-A1-14.4 131

## K

k-BIC 122

KP-F100 127, 128, 129, 130

KP-F100A 128

## L

L103-2k 121

LEDs 63  
    on CVM11 104

lenses and lens kits 111

line numbering  
    based on CVM 42, 47  
    determining 46

for CVM1 94  
for CVM11 104  
for CVM4, same as CVM1 97  
for CVM6 100  
for CVM9 100

low profile PC 20, 51

LVDS  
    CameraLink 122  
    RS-644 122

## M

maximum frame rate  
    requirements 14

Molex  
    5557D 110  
    LFH-60 96, 99, 102

MVS-8120  
    hardware description 31

## O

OPTO/TTL trigger selection 64

opto-isolated outputs 32  
    example of use 40

output  
    opto-isolated 32  
    TTL 32  
    video 33

## P

parallel I/O boards 16, 30, 37  
    installing double board 26

parallel I/O port pinout 37

part numbers  
    158-0015 113

- 158-0020 129
- 300-00208 93, 95
- 300-0175 21, 51
- 300-0214 99, 129
- 300-0220 29, 96, 124
- 300-0223 96, 124
- 300-0224 96, 124
- 300-0230 115, 116
- 300-0232 114
- 300-0266 129, 131
- 300-0274 24, 49, 53, 54, 73, 77
- 300-0287 49, 53, 54, 57, 58, 64, 65, 66, 74, 75
- 300-0288 49, 55, 57, 59, 72, 74, 75
- 300-0289 49, 55, 56, 64, 67
- 300-0313 93, 98
- 300-0316 93, 98
- 300-0332 109
- 300-0333 109
- 300-0344 93, 95
- 800-0002-01 44
- 800-0003-01 44
- 800-1000 111
- 800-5637 112
- 800-5637-1 112, 115
- 800-5712-2 76
- 800-5726-1 44
- 800-5726-3 45, 76, 77
- 800-5728-1 116
- PCI bus
  - 2.1 compliance 15
  - DMA transfers 14
  - interface 32
- PCI form factor 51
- PCI slot
  - disabled 28
- phone numbers 11
- pin numbering
  - 15-pin auxiliary I/O, parallel I/O board 54
  - 26-pin main I/O, parallel I/O board 52
  - 40-pin input on parallel I/O board 52
  - 40-pin parallel I/O connector on MVS-8120 37
  - breakout cable's power connector 116
  - CVM1 camera port 93
  - CVM11 camera port 102
  - CVM11 encoder port 108
  - CVM4 camera port 96
  - CVM6 analog camera port 98
  - CVM6 digital camera port 99
  - Hirose connector 116, 117
  - input block on external I/O module 80
  - Molex end of encoder cables 110
  - output block on external I/O module 81
- pinout
  - 40-pin parallel I/O port on MVS-8120 37
  - breakout cable's power connector 116
  - cable 300-0288 67
  - CVM1 camera port 94
  - CVM11 camera port 103
  - CVM4 camera port 97
  - CVM6 digital camera port 99
  - digital camera input port on CVM6 99
  - external power connector, parallel I/O board 51
  - Hirose connector 117
  - Hitachi KP-F100's power supply connector 131
  - Molex end of encoder cables 110
- PIO
  - stands for parallel I/O
- Plug and Play 15
- PolySwitch 63
- power indicator LEDs 63
- power requirements 36
  - for external cameras 28
- power supply

- +12 V adapter 113
- 158-0020 129
- auxiliary +12V adapter 28
- powering multiple cameras 28
- Pulnix
  - TM-9701 113, 133

## R

- recommended
  - video display adapters 15
- requirements
  - for DMA transfers 15
  - for maximum frame rate 14
  - power 36
- riser card 20, 51
- RJ-11 56
- RS-170 camera
  - and hardware triggering 41
- RS-422 140
  - supported by CVM6 98
- RS-644 140
  - supported by CVM9 98
- RS-644 LVDS 122

## S

- screw terminal connectors 74
- serial cable 131
- signal names, standardized 46, 47
- Sony
  - XC-55 133
  - XC-75 133
  - XC-ES50 134
  - XC-ST50 135
- SP-13/SP-14 127

- standard
  - electromagnetic compatibility 35
  - electromagnetic emissions 35
  - signal names 46, 47
  - Underwriters Laboratories 35
- strobe
  - numbering based on CVM 42, 47
  - numbering for CVM1 94
  - numbering for CVM11 104
  - numbering for CVM4, same as CVM1 97
  - numbering for CVM6 100
  - numbering for CVM9 100
- support phone numbers 11
- supported cameras
  - on CVM11 102
  - on CVM4 96
- switch settings
  - for Hitachi KP-F100 128
  - for Pulnix TM-9701 133
  - for Sony XC-55 133
  - for Sony XC-ST50 camera family 135

## T

- Tajimi Electronics 131
- technical support phone numbers 11
- timing
  - video 126, 138
- TM-9701 113, 133
- trigger
  - numbering based on CVM 42, 47
  - numbering for CVM1 94
  - numbering for CVM11 104
  - numbering for CVM4, same as CVM1 97
  - numbering for CVM6 100
  - numbering for CVM9 100
- TTL inputs 32

TTL lines 37

TTL outputs 32

## **U**

Underwriters Laboratories 35

universal parallel I/O board 20

UPIO

stands for universal parallel I/O

## **V**

video

bus-based output 92

timing 126, 138

video display adapters  
recommended 15

video module  
CVM overview 90

video output 33

video trigger feature 41

## **X**

XC-55 133

XC-75 133

## ■ Index

---