

PCI-DIO24/S

24-bit, TTL-compatible, digital I/O board
Onboard surge suppression/protection

User's Guide

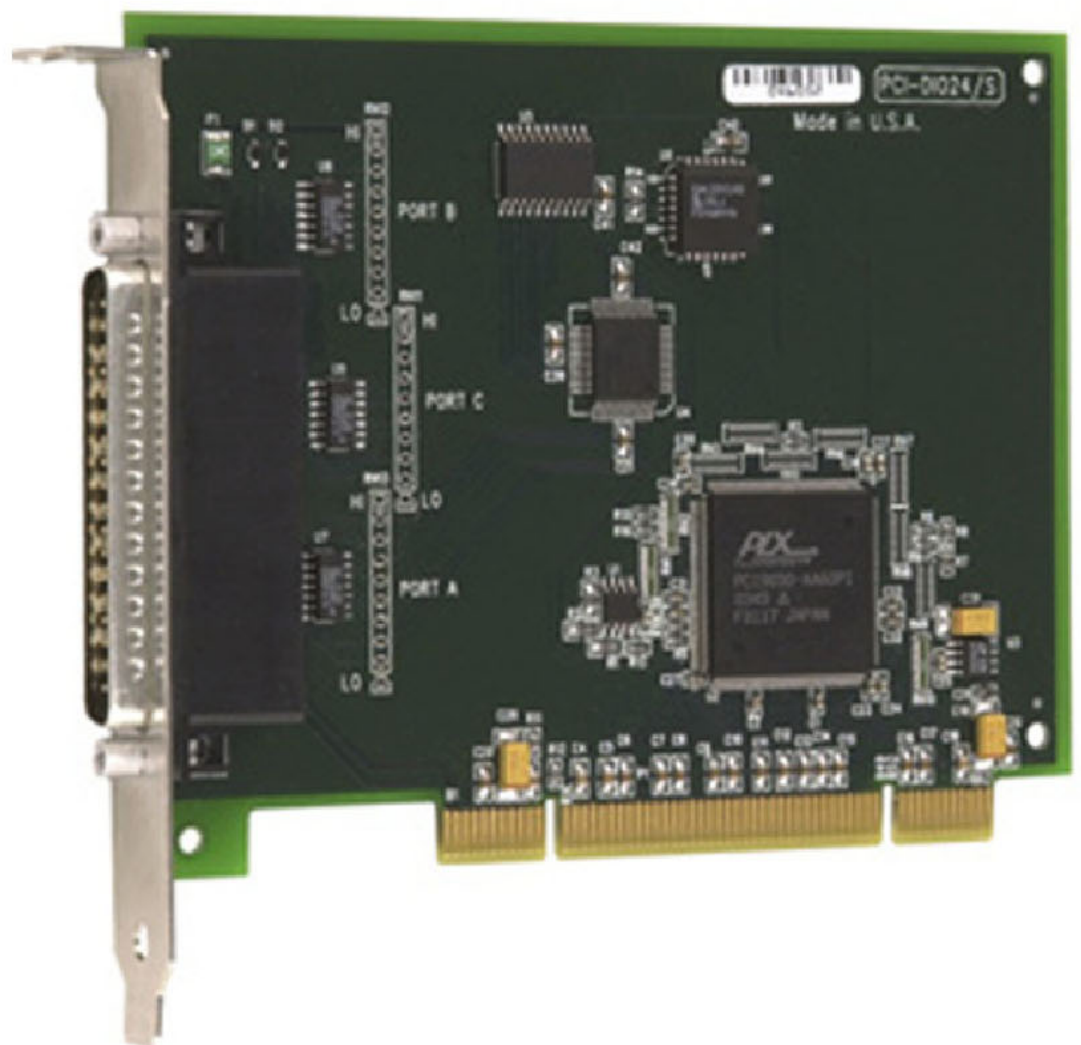

PCI-DIO24/S

Digital Input/Output

User's Guide

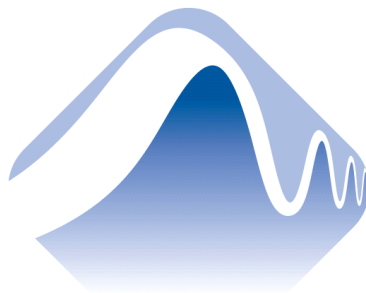

**MEASUREMENT
COMPUTING™**

Document Revision 2, May, 2006

© Copyright 2006, Measurement Computing Corporation

Your new Measurement Computing product comes with a fantastic extra —

Management committed to your satisfaction!

Refer to www.mccdaq.com/execteam.html for the names, titles, and contact information of each key executive at Measurement Computing.

Thank you for choosing a Measurement Computing product—and congratulations! You own the finest, and you can now enjoy the protection of the most comprehensive warranties and unmatched phone tech support. It's the embodiment of our two missions:

- To offer the highest-quality, computer-based data acquisition, control, and GPIB hardware and software available—at the best possible price.
- To offer our customers superior post-sale support—FREE. Whether providing unrivaled telephone technical and sales support on our latest product offerings, or continuing that same first-rate support on older products and operating systems, we're committed to you!

Lifetime warranty: Every hardware product manufactured by Measurement Computing Corporation is warranted against defects in materials or workmanship for the life of the product. Products found defective are repaired or replaced promptly.

Lifetime Harsh Environment Warranty®: We will replace any product manufactured by Measurement Computing Corporation that is damaged (even due to misuse) for only 50% of the current list price. I/O boards face some tough operating conditions—some more severe than the boards are designed to withstand. When a board becomes damaged, just return the unit with an order for its replacement at only 50% of the current list price. We don't need to profit from your misfortune. By the way, we honor this warranty for any manufacturer's board that we have a replacement for.

30 Day Money Back Guarantee: You may return any Measurement Computing Corporation product within 30 days of purchase for a full refund of the price paid for the product being returned. If you are not satisfied, or chose the wrong product by mistake, you do not have to keep it. Please call for an RMA number first. No credits or returns accepted without a copy of the original invoice. Some software products are subject to a repackaging fee.

These warranties are in lieu of all other warranties, expressed or implied, including any implied warranty of merchantability or fitness for a particular application. The remedies provided herein are the buyer's sole and exclusive remedies. Neither Measurement Computing Corporation, nor its employees shall be liable for any direct or indirect, special, incidental or consequential damage arising from the use of its products, even if Measurement Computing Corporation has been notified in advance of the possibility of such damages.

Trademark and Copyright Information

TracerDAQ, Universal Library, *InstaCal*, Harsh Environment Warranty, Measurement Computing Corporation, and the Measurement Computing logo are either trademarks or registered trademarks of Measurement Computing Corporation.

Windows, Microsoft, and Visual Studio are either trademarks or registered trademarks of Microsoft Corporation

LabVIEW is a trademark of National Instruments.

CompactFlash is a registered trademark of SanDisk Corporation.

All other trademarks are the property of their respective owners.

Information furnished by Measurement Computing Corporation is believed to be accurate and reliable. However, no responsibility is assumed by Measurement Computing Corporation neither for its use; nor for any infringements of patents or other rights of third parties, which may result from its use. No license is granted by implication or otherwise under any patent or copyrights of Measurement Computing Corporation.

All rights reserved. No part of this publication may be reproduced, stored in a retrieval system, or transmitted, in any form by any means, electronic, mechanical, by photocopying, recording, or otherwise without the prior written permission of Measurement Computing Corporation.

Notice

Measurement Computing Corporation does not authorize any Measurement Computing Corporation product for use in life support systems and/or devices without prior written consent from Measurement Computing Corporation. Life support devices/systems are devices or systems which, a) are intended for surgical implantation into the body, or b) support or sustain life and whose failure to perform can be reasonably expected to result in injury. Measurement Computing Corporation products are not designed with the components required, and are not subject to the testing required to ensure a level of reliability suitable for the treatment and diagnosis of people.

Table of Contents

About this User's Guide	v
What you will learn from this user's guide	v
Conventions in this user's guide	v
Where to find more information	v
Chapter 1	
Introducing the PCI-DIO24/S	1-1
Overview: PCI-DIO24/S features	1-1
Software features	1-1
Chapter 2	
Installing the PCI-DIO24/S	2-1
What comes with your PCI-DIO24/S shipment?	2-1
Hardware	2-1
Additional documentation	2-1
Unpacking the hardware	2-2
Installing the software	2-2
Installing the hardware	2-2
Connecting the board for I/O operations	2-3
Connectors, cables – main I/O connector	2-3
Pin out – main I/O connector	2-3
Cables	2-4
Field wiring, signal termination and conditioning	2-4
Chapter 3	
Programming and Developing Applications	3-1
Programming languages	3-1
Packaged applications programs	3-1
Register-level programming	3-1
Chapter 4	
Functional Details	4-1
Signal level control	4-2
Chapter 5	
Specifications	5-1
Digital input/output	5-1
Interrupts	5-1
Power consumption	5-1
Environmental	5-1
Mechanical	5-2
I/O pins protection	5-2
Connector and pin out	5-2

About this User's Guide

What you will learn from this user's guide

This user's guide explains how to install, configure and use the PCI-DIO24/S digital I/O board. This user's guide also refers you to related documents available on our web site and to technical support resources.

Conventions in this user's guide

For more information on ...

Text presented in a box signifies additional information and helpful hints related to the subject matter you are reading.

Caution! Shaded caution statements present information to help you avoid injuring yourself and others, damaging your hardware, or losing your data.

<#:#> Angle brackets that enclose numbers separated by a colon signify a range of numbers, such as those assigned to registers, bit settings, etc.

bold text **Bold** text is used for the names of objects on the screen, such as buttons, text boxes, and check boxes. For example:
1. Insert the disk or CD and click the **OK** button.

italic text *Italic* text is used for the names of manuals and help topic titles, and to emphasize a word or phrase. For example:
The *InstaCal*® installation procedure is explained in the *Quick Start Guide*.
Never touch the exposed pins or circuit connections on the board

Where to find more information

- MCC's *Specifications: PCI-DIO24/S* (the PDF version of the Electrical Specification Chapter in this guide) is available on our web site at www.mccdaq.com/pdfs/PCI-DIO24S.pdf.
- MCC's *Quick Start Guide* is available on our web site at www.mccdaq.com/PDFmanuals/DAQ-Software-Quick-Start.pdf.
- MCC's *Guide to Signal Connections* is available on our web site at www.mccdaq.com/signals/signals.pdf.
- MCC's *Universal Library User's Guide* is available on our web site at www.mccdaq.com/PDFmanuals/sm-ul-user-guide.pdf.
- MCC's *Universal Library Function Reference* is available on our web site at www.mccdaq.com/PDFmanuals/sm-ul-functions.pdf.
- MCC's *Universal Library for LabVIEW™ User's Guide* is available on our web site at www.mccdaq.com/PDFmanuals/SM-UL-LabVIEW.pdf.

PCI-DIO24/S User's Guide (this document) is also available on our web site at www.mccdaq.com/PDFmanuals/PCI-DIO24-S.pdf.

Introducing the PCI-DIO24/S

Overview: PCI-DIO24/S features

This manual explains how to install, configure and use the PCI-DIO24/S digital I/O board. You can use this board in a variety of digital applications to control logic devices such as switches, gauges, relays, pumps, and sensors.

The PCI-DIO24/S is a 24-bit, TTL-compatible digital I/O board. Digital I/O lines are accessed through a 37-pin connector. Digital I/O and interrupt pins are protected from electrostatic discharges of up to ± 15 kV (air) and ± 8 kV (contact).

An on-board, industry standard 82C55 programmable peripheral interface chip provides the 24 discrete digital I/O lines in three eight-bit ports (Port A, Port B, and Port C) for each board. Port C can be further divided into two four-bit ports (Port C-HI and Port C-LO). You can configure each port independently for either input or output. The PCI-DIO24/S supports 5V or 3.3V TTL/CMOS I/O signaling.

The PCI-DIO24/S has open locations where you can install a pull-up or pull-down resistor for each port. All I/O bits are set to input mode on power up and reset.

The PCI-DIO24/S board is completely plug-and-play, with no jumpers or switches to set. All board addresses are set by your system's plug-and-play software.

Software features

For information on the features of *InstaCal* and the other software included with your PCI-DIO24/S, refer to the *Quick Start Guide* that shipped with your device. The *Quick Start Guide* is also available in PDF at www.mccdaq.com/PDFmanuals/DAQ-Software-Quick-Start.pdf.

Check <http://www.mccdaq.com/download.htm> for the latest software version or versions of the software supported under less commonly used operating systems.

Installing the PCI-DIO24/S

What comes with your PCI-DIO24/S shipment?

As you unpack your board, make sure each of the items shown below is included.

Hardware

- PCI-DIO24/S

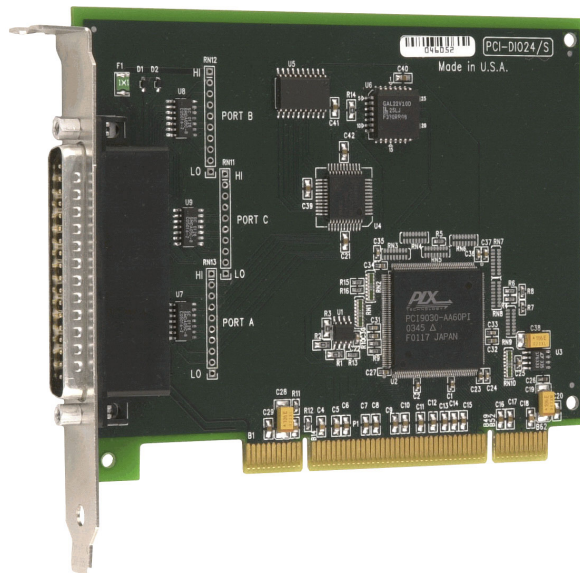

- Cables



C37FFS-x

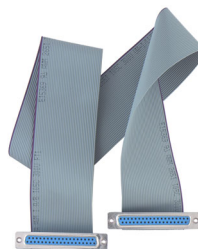

C37FF-x

- Signal termination and conditioning accessories

MCC provides signal termination and conditioning boards that you can use with the PCI-DIO24/S. Refer to the "[Field wiring, signal termination and conditioning](#)" section on page 2-4 for a complete list of compatible accessory products.

Additional documentation

In addition to this hardware user's guide, you should also receive the *Quick Start Guide* (available in PDF at www.mccdaq.com/PDFmanuals/DAQ-Software-Quick-Start.pdf). This booklet supplies a brief description of the software you received with your PCI-DIO24/S and information regarding installation of that software. Please read this booklet completely before installing any software or hardware.

Unpacking the hardware

As with any electronic device, you should take care while handling to avoid damage from static electricity. Before removing the PCI-DIO24/S from its packaging, ground yourself using a wrist strap or by simply touching the computer chassis or other grounded object to eliminate any stored static charge.

If any components are missing or damaged, notify Measurement Computing Corporation immediately by phone, fax, or e-mail:

- Phone: 508-946-5100 and follow the instructions for reaching Tech Support.
- Fax: 508-946-9500 to the attention of Tech Support
- Email: techsupport@mccdaq.com

Installing the software

Install the software included with your board *before* you install the hardware. Installing the software first ensures that the information required for proper board detection is installed and available at boot up.

Refer to the *Quick Start Guide* for instructions on installing the software on the *Measurement Computing Data Acquisition Software CD*. This booklet is available in PDF at www.mccdaq.com/PDFmanuals/DAQ-Software-Quick-Start.pdf.

Installing the hardware

The PCI-DIO24/S is completely plug-and-play, with no switches or jumpers to set. Configuration is controlled by your system's plug-and-play software. To install your board, follow the steps below.

Install the MCC DAQ software before you install your board

The driver needed to run your board is installed with the MCC DAQ software. Therefore, you need to install the MCC DAQ software before you install your board. Refer to the *Quick Start Guide* for instructions on installing the software.

1. Turn your computer off, open it up, and insert your board into an available PCI slot.
2. Close your computer and turn it on.

If you are using an operating system with support for plug-and-play (such as Windows 2000 or Windows XP), a dialog box pops up as the system loads indicating that new hardware has been detected. If the information file for this board is not already loaded onto your PC, you will be prompted for the disk containing this file. The MCC DAQ software contains this file. If required, insert the *Measurement Computing Data Acquisition Software CD* and click **OK**.

3. To test your installation and configure your board, run the *InstaCal* utility you installed in the previous section. Refer to the *Quick Start Guide* that came with your board for information on how to initially set up and load *InstaCal*.

Connecting the board for I/O operations

Connectors, cables – main I/O connector

Table 2-1 lists the board connectors, compatible cables, and compatible accessory products for the PCI-DIO24/S.

Table 2-1. Board connectors, cables, and accessory equipment

I/O connector type	CONN37DR male
Compatible cable	C37FFS- <i>x</i> , where <i>x</i> =5 or 10 feet (Figure 2-2) C37FF- <i>x</i> , where <i>x</i> = length in feet (Figure 2-3)
Compatible accessory products (with the C37FFS- <i>x</i> and C37FF- <i>x</i> cables)	CIO-MINI37, CIO-MINI37/DST SCB-37 CIO-ERB24 CIO-ERB08 SSR-RACK24 SSR-RACK08

Pin out – main I/O connector

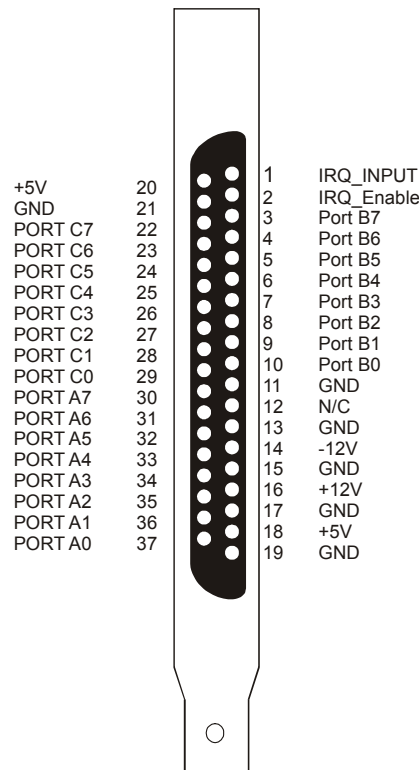

Figure 2-1. PCI-DIO24/S I/O connector pin out

Cables

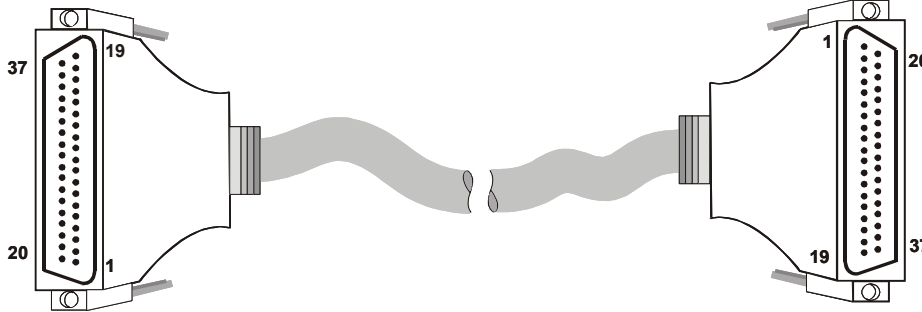

Figure 2-2. C37FFS-x cable

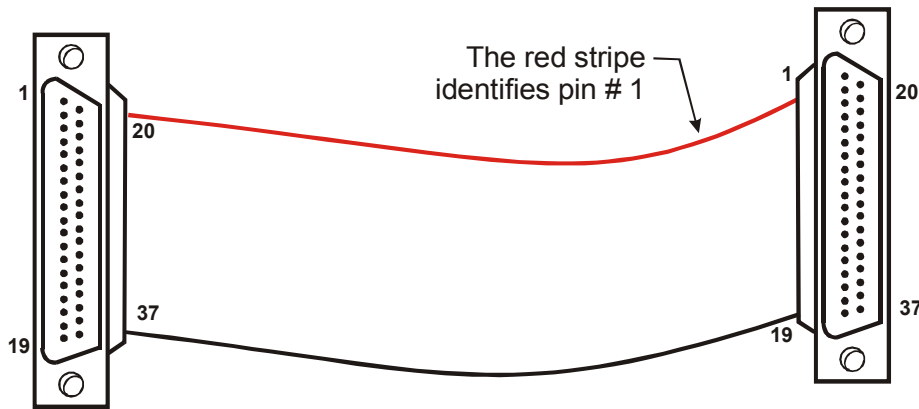

Figure 2-3. C37FF-x cable

Field wiring, signal termination and conditioning

You can connect the PCI-DIO24/S to the following accessory boards using the C37FF-x or C37FFS-x cable.

- CIO-MINI37 – 37-pin screw terminal board. Details on this product are available on our web site at www.mccdaq.com/cbicatalog/cbiproduct.asp?dept_id=102&pf_id=1543.
- SCB-37 – 37-conductor, shielded signal connection/screw terminal box. Details on this product are available on our web site at www.mccdaq.com/cbicatalog/cbiproduct.asp?dept_id=196&pf_id=1166.
- CIO-ERB24 – 24 Form C, 6A relays. Details on this product are available on our web site at www.mccdaq.com/cbicatalog/cbiproduct.asp?dept_id=123&pf_id=241.
- CIO-ERB08 – Eight Form C, 6A relays. Details on this product are available on our web site at www.mccdaq.com/cbicatalog/cbiproduct.asp?dept_id=123&pf_id=240.
- SSR-RACK24 – 24-channel solid state I/O module rack. Details on this product are available on our web site at www.mccdaq.com/cbicatalog/cbiproduct.asp?dept_id=122&pf_id=1193.
- SSR-RACK08 – 24-channel solid state I/O module rack. Details on this product are available on our web site at www.mccdaq.com/cbicatalog/cbiproduct.asp?dept_id=122&pf_id=620.

Programming and Developing Applications

After following the installation instructions in Chapter 2, your board should now be installed and ready for use.

Programming languages

Measurement Computing's Universal Library provides access to board functions from a variety of Windows programming languages. If you are planning to write programs, or would like to run the example programs for Visual Basic® or any other language, please refer to the *Universal Library User's Guide* (available on our web site at www.mccdaq.com/PDFmanuals/sm-ul-user-guide.pdf).

Packaged applications programs

Many packaged application programs, such as SoftWIRE®, Labtech Notebook™ and HP-VEE™ now have drivers for your board. If the package you own does not have drivers for the board, please fax or e-mail the package name and the revision number from the install disks. We will research the package for you and advise how to obtain drivers.

Some application drivers are included with the Universal Library package, but not with the application package. If you have purchased an application package directly from the software vendor, you may need to purchase our Universal Library and drivers. Please contact us by phone, fax or e-mail:

- Phone: 508-946-5100 and follow the instructions for reaching Tech Support.
- Fax: 508-946-9500 to the attention of Tech Support
- Email: techsupport@mccdaq.com

Register-level programming

You should use the Universal Library or one of the packaged application programs mentioned above to control your board. Only experienced programmers should try register-level programming.

If you need to program at the register level in your application, refer to the *Register Map for the PCI-DIO24, PCI-DIO24H, PCI-DIO24/S, and PCI-DIO24/LP*. This document is available on our website at www.mccdaq.com/registermaps/RegMapPCI-DIO24X.pdf.

Functional Details

The PCI-DIO24/S board features the following:

- 82C55 digital I/O chip interfaced to the PCI bus. The I/O pins of an 82C55 are bi-directional CMOS TTL level.
- 24-bits of digital I/O
- 37-pin I/O connector
- Digital I/O and interrupt pins are protected from electrostatic discharges of up to ± 15 kV (air) and ± 8 kV (contact).

The 82C55 provides the 24-bit digital I/O channels into three eight-bit ports labeled **Port A**, **Port B** and **Port C**. Port C is further divided into two four-bit ports. You can program each port for input or output.

PCI-DIO24/S functions are illustrated in the block diagram shown here.

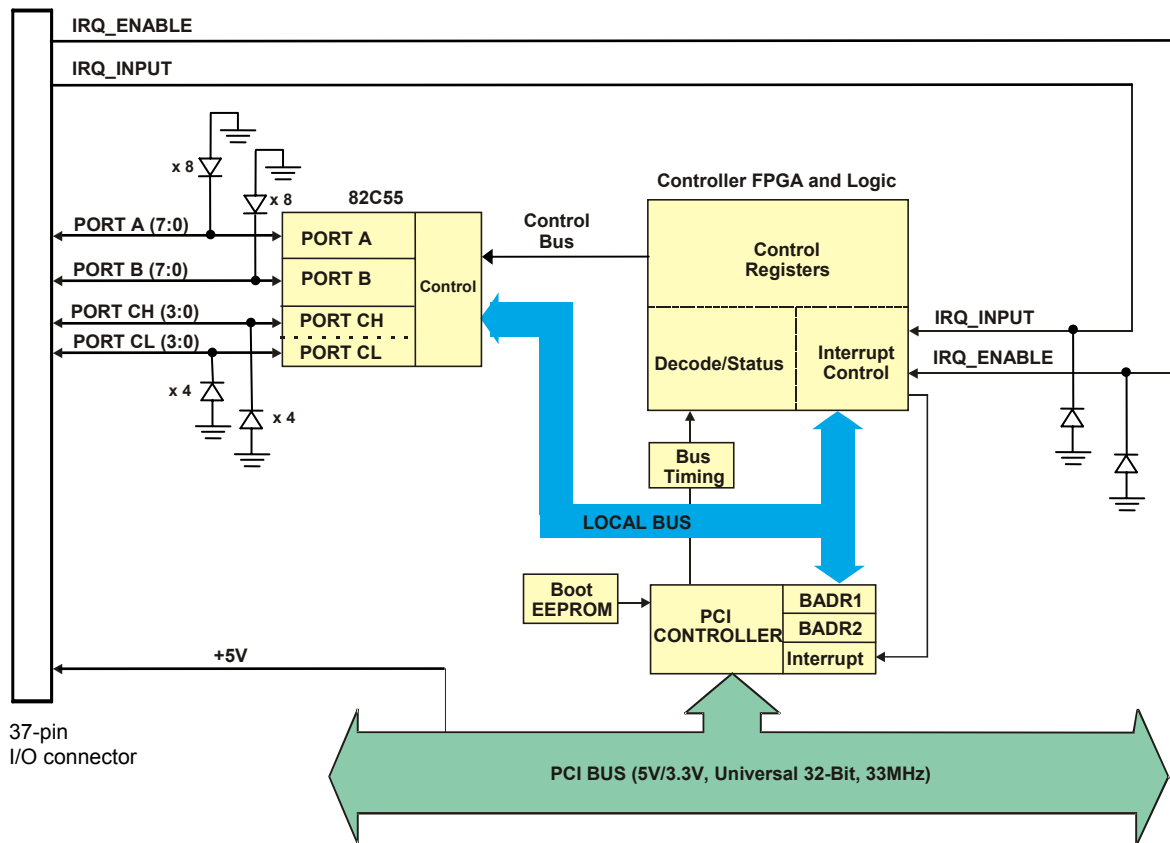

Figure 4-1. PCI-DIO24/S functional block diagram

For more information on digital signal connections

For general information about digital signal connections and digital I/O techniques, refer to the *Guide to Signal Connections* (available on our web site at www.mccdaq.com/signals/signals.pdf).

Caution! Do not connect high current/voltage devices directly to the PCI-DIO24/S or you may damage the board.

Signal level control

All I/O bits are set to a high impedance input mode on power up and reset. To prevent unwanted signal levels, and to drive all outputs on the device you are controlling to a known state after power up or reset, install pull-up or pull-down resistors.

A pull-up resistor pulls all digital pins up to +5 V (high logic level). A pull-down resistor pulls all digital pins down to 0 V (low logic level).

Each board has open locations where you can install a 2.2 K Ω , eight-resistor single inline package (SIP) resistor network for each port. The SIP is made up of eight 2.2 K resistors. One side of each resistor is connected to a single common point and brought out to a pin. The common line is marked with a dot or line at one end of the SIP. The remaining resistor ends are brought out to the other eight pins (see Figure 4-2).

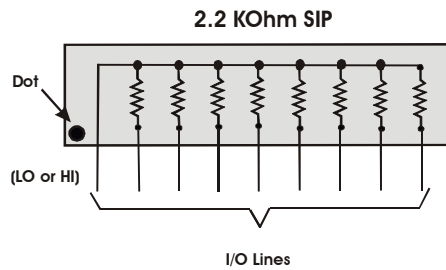

Figure 4-2. Eight-Resistor SIP Schematic

Each port provides 10 holes. Install an SIP on the board at the locations labeled **Port A**, **Port B** and **Port C** (see Figure 4-3).

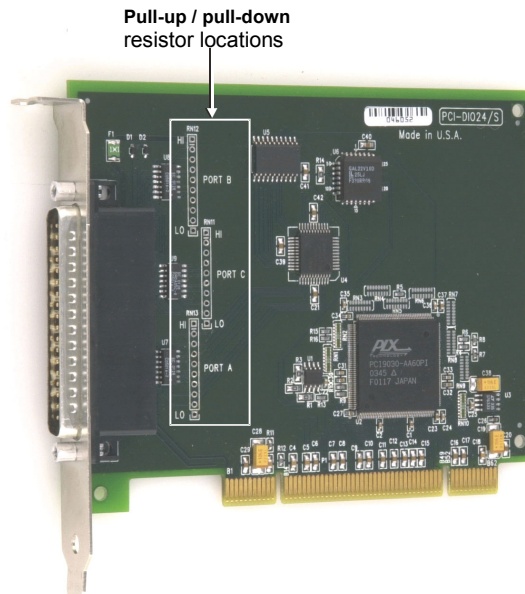

Figure 4-3. Pull-up/down resistor locations

The end labeled **HI** connects to +5 V. The end labeled **LO** connects to GND. The eight holes in the middle (n0 – n7) connect to the eight lines of the port (Port A, B, or C). Figure 4-4 shows an SIP resistor network installed in both pull-up and pull-down positions.

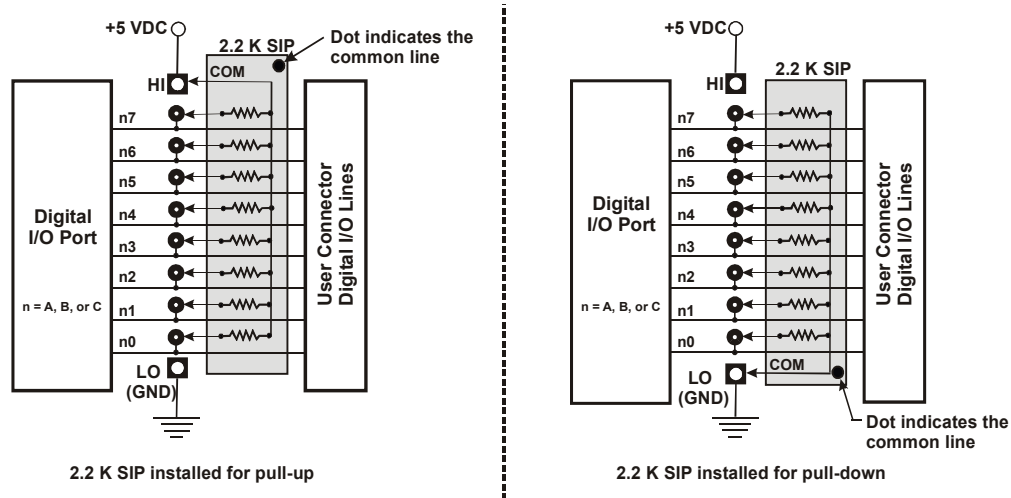

Figure 4-4. Pull-up and pull-down resistor SIP schematic

To pull up the digital lines for a particular port, install the resistor with the common pin at the **HI** end. To pull down the digital lines for a particular port, install the resistor with the common pin at the **LO** end. When installed, the SIP resistors establish either a high or low logic level for each port when the board is in input mode.

Install MCC SIP packs

When installing pull-up and pull-down resistor SIP packs, we recommend using a 2.2 K, eight-resistor SIP (MCC part number SP-K2.29C).

Specifications

Typical for 25 °C unless otherwise specified.

Specifications in *italic text* are guaranteed by design.

Digital input/output

Table 1. Digital I/O specifications

Digital type	82C55
Number of I/O	24 (Port A0 through Port C7)
Configuration	2 banks of 8 and 2 banks of 4 or
	3 banks of 8 or
	2 banks of 8 with handshake
<i>Input low voltage</i>	<i>0.8 V max</i>
<i>Input high voltage</i>	<i>2.2 V min</i>
<i>Output low voltage (IOL = 2.5 mA)</i>	<i>0.5 V max</i>
<i>Output high voltage (IOH = -2.5 mA)</i>	<i>2.4 V min</i>
<i>Absolute maximum input voltage</i>	<i>-0.5 V, +6 V</i>
<i>Power-up / reset state</i>	<i>Input mode (high impedance)</i>
Pull-up/pull-down resistors	Dual footprint allows pull-up or pull-down configuration.

Interrupts

Table 2. Interrupt specifications

Interrupts	INTA# - mapped to IRQn via PCI BIOS at boot-time
Interrupt enable	External (IRQ_ENABLE) active low, disabled by default through internal resistor to TTL high and programmable through PLX9030
Interrupt sources	External source (IRQ_INPUT) Polarity programmable through PLX9030 Edge or level triggered programmable through PLX9030 Assertion time: 40 ns min

Power consumption

Table 3. Power consumption specifications

+5 V operating	240 mA typical, 350 mA max. Does not include power consumed through the I/O connector.
+5 V available at I/O connector	300 mA max, protected with a resettable fuse
Resettable fuse	Raychem type <i>miniSMDC110</i> . Hold current: 1.1 A max Series resistance 0.21 Ohms max.

Environmental

Table 4. Environmental specifications

Operating temperature range	0 to 70°C
Storage temperature range	-40 to 100°C
Humidity	0 to 95% non-condensing

Mechanical

Table 5. Mechanical specifications

Card dimensions	PCI length: 131.8 mm (L) x 106.7 mm (W) x 18.4 mm (H)
Form factor	Universal PCI keying. Compatible with either 3.3 V or 5 V PCI signaling environments.

I/O pins protection

Table 6. Static discharge protection specifications

DIO lines protected	Port A[7:0], Port B[7:0], Port C[7:0], IRQIN, IRQEN
On board chip	SEMTECH SMDA05C-8, SD05
ESD protection level	± 15 kV (air), ± 8 kV (contact)
DIO maximum voltage	6V

Connector and pin out

Table 7. Connector specifications

I/O connector type	CONN37DR male
Compatible cables	C37FF-x, C37FFS-x, x = Length in feet.
Compatible accessories	CIO-MINI37, CIO-MINI37/DST SCB-37 CIO-ERB24 CIO-ERB08 SSR-RACK24 SSR-RACK08

Table 8. Connector pin out

Pin	Signal Name	Pin	Signal Name
1	IRQ_INPUT	20	+5V
2	IRQ_ENABLE	21	GND
3	Port B7	22	Port C7
4	Port B6	23	Port C6
5	Port B5	24	Port C5
6	Port B4	25	Port C4
7	Port B3	26	Port C3
8	Port B2	27	Port C2
9	Port B1	28	Port C1
10	Port B0	29	Port C0
11	GND	30	Port A7
12	N/C	31	Port A6
13	GND	32	Port A5
14	-12V	33	Port A4
15	GND	34	Port A3
16	+12V	35	Port A2
17	GND	36	Port A1
18	+5V	37	Port A0
19	GND		

Measurement Computing Corporation
10 Commerce Way
Suite 1008
Norton, Massachusetts 02766
(508) 946-5100
Fax: (508) 946-9500
E-mail: info@mccdaq.com
www.mccdaq.com