

COGNEX

CC24 Communication Card

Hardware Manual

Legal Notices

The software described in this document is furnished under license, and may be used or copied only in accordance with the terms of such license and with the inclusion of the copyright notice shown on this page. Neither the software, this document, nor any copies thereof may be provided to, or otherwise made available to, anyone other than the licensee. Title to, and ownership of, this software remains with Cognex Corporation or its licensor. Cognex Corporation assumes no responsibility for the use or reliability of its software on equipment that is not supplied by Cognex Corporation. Cognex Corporation makes no warranties, either express or implied, regarding the described software, its merchantability, non-infringement or its fitness for any particular purpose.

The information in this document is subject to change without notice and should not be construed as a commitment by Cognex Corporation. Cognex Corporation is not responsible for any errors that may be present in either this document or the associated software.

Companies, names, and data used in examples herein are fictitious unless otherwise noted. No part of this document may be reproduced or transmitted in any form or by any means, electronic or mechanical, for any purpose, nor transferred to any other media or language without the written permission of Cognex Corporation.

Cognex P/N INS-597-0064-01 Rev. B

Copyright © 2014. Cognex Corporation. All Rights Reserved.

Portions of the hardware and software provided by Cognex may be covered by one or more U.S. and foreign patents, as well as pending U.S. and foreign patents listed on the Cognex web site at: <http://www.cognex.com/patents>.

The following are registered trademarks of Cognex Corporation:

Cognex, 2DMAX, Advantage, Alignplus, Assemblyplus, Check it with Checker, Checker, Cognex Vision for Industry, Cognex VSOC, CVL, DataMan, DisplayInspect, DVT, EasyBuilder, Hotbars, IDMax, In-Sight, Laser Killer, MVS-8000, OmniView, PatFind, PatFlex, PatInspect, PatMax, PatQuick, SensorView, SmartView, SmartAdvisor, SmartLearn, UltraLight, Vision Solutions, VisionPro, VisionView

The following are trademarks of Cognex Corporation:

The Cognex logo, 1DMax, 3D-Locate, 3DMax, BGAll, CheckPoint, Cognex VSoC, CVC-1000, FFD, iLearn, In-Sight (design insignia with cross-hairs), In-Sight 2000, InspectEdge, Inspection Designer, MVS, NotchMax, OCRMax, ProofRead, SmartSync, ProfilePlus, SmartDisplay, SmartSystem, SMD4, VisiFlex, Xpand

Other product and company trademarks identified herein are the trademarks of their respective owners.

Symbols

The following symbols indicate safety precautions and supplemental information.

 **WARNING:** This symbol indicates the presence of a hazard that could result in death, serious personal injury or electrical shock.



 **CAUTION:** This symbol indicates the presence of a hazard that could result in property damage.

 **Note:** Notes provide supplemental information about a subject.

 **Tip:** Tips provide helpful suggestions and shortcuts that may not otherwise be apparent.

Regulations/Conformity

i Note: For the most up-to-date regulations and conformity information, please refer to the Cognex online support site: <http://www.cognex.com/Support>.

Safety and Regulatory	
	Cognex Communication Card: Regulatory Model 1AAR
FCC	FCC Part 15, Class A This device complies with Part 15 of the FCC Rules. Operation is subject to the following two conditions: (1) this device may not cause harmful interference; and (2) this device must accept any interference received, including interference that may cause undesired operation. This equipment generates, uses, and can radiate radio frequency energy and, if not installed and used in accordance with the instruction manual, may cause harmful interference to radio communications. Operation of this equipment in a residential area is likely to cause harmful interference in which case the user will be required to correct the interference at their own expense.
KCC 	Regulatory Model MSIP-REM-CGX-1AAR
RoHS	Compliant to the latest applicable Directive.

Precautions

Observe these precautions when installing the Cognex Communication card to reduce the risk of injury or equipment damage:

- To reduce the risk of damage or malfunction due to over-voltage, line noise, electrostatic discharge (ESD), power surges, or other irregularities in the power supply, route all cables and wires away from high-voltage power sources.
- Do not install the Communication card in areas directly exposed to environmental hazards such as excessive heat, dust, moisture, humidity, impact, vibration, corrosive substances, flammable substances, or static electricity.
- The Communication card does not contain user-serviceable parts. Do not make electrical or mechanical modifications to the components. Unauthorized modifications may void your warranty.
- Service loops should be included with all cable connections.
- Cable shielding can be degraded or cables can be damaged or wear out more quickly if a service loop or bend radius is tighter than 10X the cable diameter. The bend radius must be at least six inches from the connector.
- Changes or modifications not expressly approved by the party responsible for regulatory compliance could void the user's authority to operate the equipment.
- Class A Equipment (broadcasting and communication equipment for office work): Seller and user shall be notified that this equipment is suitable for electromagnetic equipment for office work (Class A) and can be used outside the home.
- This device should be used in accordance with the instructions in this manual.
- All specifications are for reference purpose only and may be changed without notice.

Table of Contents

Legal Notices	2
Symbols	3
Regulations/Conformity	4
Precautions	5
Table of Contents	6
Introduction	7
Support	7
Accessories	7
Connectors and Indicators	8
Installation	9
Host PC Requirements	9
Select a PCI Express Slot	9
Install the Communication Card to the PC	10
Connect I/O Devices (Optional)	10
Connect the Breakout Cable	10
Connect the I/O Terminal Block Cable and Terminal Block	11
Connect to an Industrial Ethernet Device (Optional)	12
Specifications	13
Communication Card Specifications	13
Inputs	14
Outputs	15
Encoder Inputs	16
I-ENET Port	17
Mini Delta Ribbon Connector	18
Breakout Cable Specifications	20
I/O Terminal Block Cable Specifications	22
Terminal Block Assignments	24
Terminal Block LEDs	25
Communication Card Dimensions	26
Wire Inputs and Outputs	27
Input from PLC - Current Sinking	27
Input from PLC - Current Sourcing	28
Output to PLC - Current Sinking	29
Output to PLC - Current Sourcing	30
Output to Pilot Light - Current Sinking	31
Output to Pilot Light - Current Sourcing	32
Differential Encoder Configuration	33
Single-Ended Encoder Configuration	34

Introduction

The Cognex Communication card is a PCI Express x1 card that can be installed to a standard PC, and is designed for easy integration with Cognex's industry-leading software applications. The Communication card also provides:

- 8 inputs, optically isolated.
- 16 outputs, optically isolated.
- Support for current sinking (NPN) and current sourcing (PNP) devices.
- Encoder inputs, for connecting a single-ended or differential encoder.
- Industrial Ethernet protocol support.
- Software security.

Support

Several resources are available to assist you in using the Communication card:

- The *Cognex VisionPro* help file, included with VisionPro software.
- VisionPro online support: <http://www.cognex.com/Support/VisionPro>.

Accessories

The following optional components can be purchased separately. For a complete list of options and accessories, contact your local Cognex sales representative.

Component	Description
Breakout Cable	Provides access to the Communication card's input, output and encoder lines. The Breakout cable is not terminated. For more information, refer to Breakout Cable Specifications on page 20 .
Terminal Block and I/O Terminal Block Cable	A DIN rail-mountable terminal block and I/O Terminal Block cable (MDR36 to DB37) that provides access to the Communication card's input, output and encoder lines. For more information, refer to Terminal Block Assignments on page 24 and I/O Terminal Block Cable Specifications on page 22 .

Connectors and Indicators



Connector/Indicator		Function
1	Mini Delta Ribbon Connector	The Mini Delta Ribbon (MDR) connector is a 36-pin connector that provides access to inputs, output and encoder lines via the Breakout cable or I/O Terminal Block cable. For more information, refer to Mini Delta Ribbon Connector on page 18 .
2	I-ENET Port and LEDs	The I-ENET port is a 10/100 RJ-45 Ethernet port that can be connected to a network that is dedicated to industrial Ethernet devices (for example, PLCs or robots) to communicate with the devices using supported industrial Ethernet protocols. The green LED blinks when a network connection is detected. The yellow LED blinks when network activity is detected. For more information, refer to I-ENET Port on page 17 .

Installation

This section describes the connection of the Communication card to its standard and optional components. For a complete list of options and accessories, contact your Cognex sales representative.

Note: Cables are sold separately.

CAUTION: All cable connectors are “keyed” to fit the connectors on the Communication card; do not force the connections or damage may occur.

Host PC Requirements

To install the Communication card, the host PC should meet the following minimum requirements:

- The PC's motherboard's chip set must be fully compliant with the PCI Express Revision 1.0a, 1.1, or 2.0 specifications.
- One available PCI Express card slot.
- One available CD-ROM or DVD-ROM drive (or access to one over a network) to install the Cognex software.

Additional requirements may be imposed by your Cognex software package. Check the Cognex software's release notes for the software's requirements, if any, on:

- Minimum recommended CPU speed.
- Host operating system, including the supported service pack level.
- Supported video cards.
- Desktop color depth (the number of colors displayable).
- Desktop size (the number of pixels displayable in width and height on your screen).
- The presence of a mouse or other pointing device.

Select a PCI Express Slot

PCI Express card slots come in four sizes: x1, x4, x8 and x16. The Communication card has an x1 bus interface and can be placed in any x1, x4, x8, or x16 PCI Express slot.

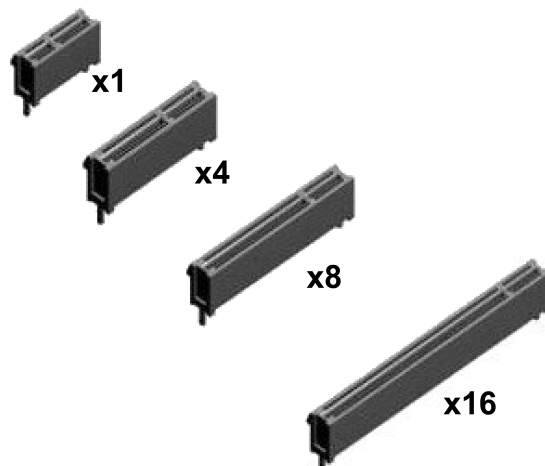

Install the Communication Card to the PC

⚠ CAUTION: Electrostatic discharge (ESD) can damage the electronic components of the Cognex hardware; wear a grounded, static-dissipating wrist strap for ESD protection.

1. Power off the PC and remove its cover.
2. Select a PCI Express x1 slot. Remove the slot cover and store it for future use.
3. Press the board into the slot until it is firmly seated.
4. Replace the PC's cover.

⚠ CAUTION: Do not power on the PC until you have connected any I/O devices to the Communication card.

Connect I/O Devices (Optional)

The Communication card supports the connection of PLCs and photoelectric sensors, as well as general use I/O devices, such as relays, indicator lights and reject mechanisms. The Communication card also supports connection to either a single-ended or differential encoder. For more information, refer to [Inputs on page 14](#), [Outputs on page 15](#) and [Encoder Inputs on page 16](#).

There are two options for connecting I/O devices: using the accessory Breakout cable; or the I/O Terminal Block cable and DIN-rail mountable Terminal Block accessories.

- If connecting the Breakout cable to the Communication card, the cable's flying lead wires can be connected directly to the applicable I/O device.
- If connecting the I/O Terminal Block cable to the Communication card, the cable is connected to the Terminal Block, which can be connected directly to the applicable I/O device.

Connect the Breakout Cable

1. Determine how I/O devices will be connected to the Communication card's inputs and outputs. Refer to [Wire Inputs and Outputs on page 27](#) for common wiring configurations.
2. Make sure all I/O devices and the PC hosting the Communication card are powered off.
3. Connect the Breakout cable's MDR connector to the MDR connector on the Communication card.

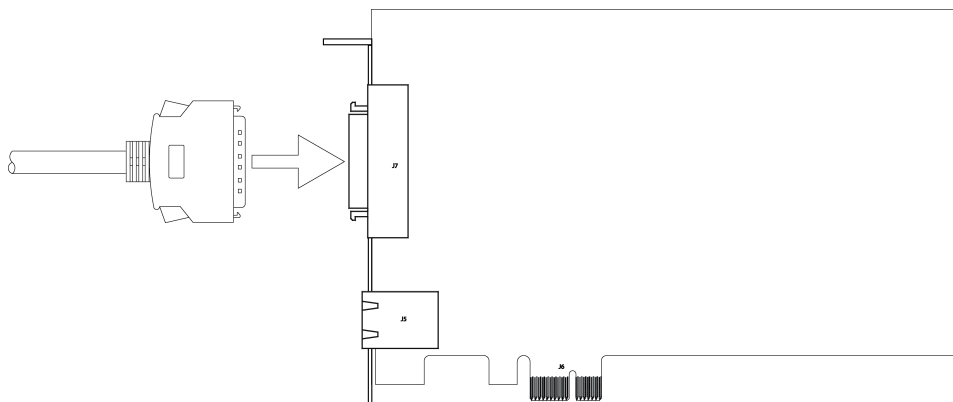

4. Connect the Breakout cable's flying lead wires to the applicable I/O device. Refer to [Breakout Cable Specifications on page 20](#) for cable pin-outs.

Connect the I/O Terminal Block Cable and Terminal Block

1. Determine how I/O devices will be connected to the Communication card's inputs and outputs. Refer to [Wire Inputs and Outputs on page 27](#) for common wiring configurations.
2. Make sure all I/O devices and the PC hosting the Communication card are powered off.
3. Connect the I/O Terminal Block cable's MDR connector to the MDR connector on the Communication card.

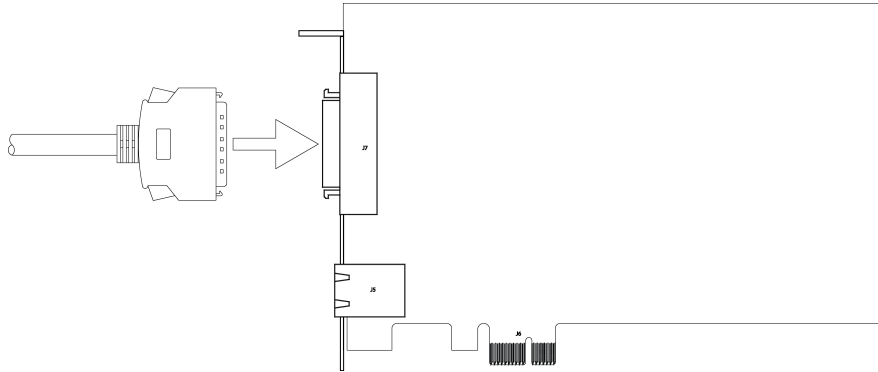

4. Connect the I/O Terminal Block cable's DB37 connector to the DB37 connector on the Terminal Block.

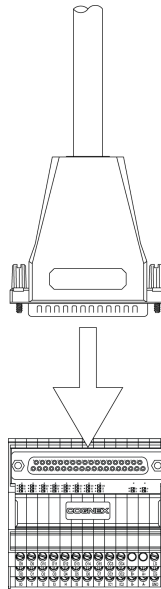

5. Attach the Terminal Block to a convenient surface. It is configured for NS 35 DIN rail mounting.
6. Use a screwdriver to loosen the M3 wire retention screws on the Terminal Block. Refer to [Terminal Block Assignments on page 24](#) for terminal block pin assignments.
7. Insert the input, output and encoder wires (12- 24 AWG, solid or stranded wire) into the terminals.
8. Tighten the wire retention screws to secure the wire leads in the Terminal Block; the maximum torque is 0.5 Nm to 0.6 Nm (4.4 in-lb to 5.3 in-lb).
9. Connect the other end of the input, output and encoder wires to the applicable I/O device.

Connect to an Industrial Ethernet Device (Optional)

The Communication card can be connected to a network that is dedicated to industrial Ethernet devices (for example, PLCs or robots) to communicate with the devices using supported industrial Ethernet protocols. Connect one end of a 10/100 RJ-45 Ethernet cable to the Communication card's I-ENET port and connect the other end of the cable to a network switch/router.

Note:

- To avoid electromagnetic interference, the Ethernet cable must be shielded. Cognex strongly recommends Cat 5e or Cat 6 Ethernet cables with S/STP shielding.
- The I-ENET port is dedicated to industrial Ethernet communications and cannot be used to connect to Cognex industrial devices or a Gigabit Ethernet network.

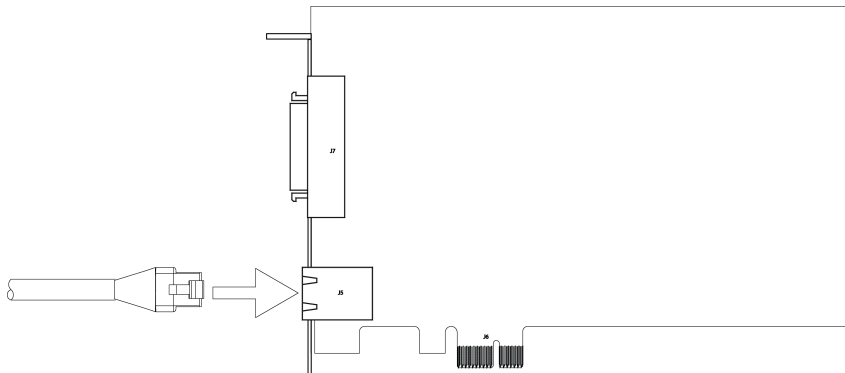

Specifications

The following sections list general specifications for the Communication card.

Communication Card Specifications

Specifications	Description
Bus Interface	PCI Express, x1 Gen2
Bus Interface Options	Any PCIe slot.
Inputs	8 optically isolated discrete inputs.
Outputs	16 optically isolated discrete outputs.
Encoder Inputs	4 non-isolated encoder inputs.
I-ENET Port	1 RJ-45 Ethernet port, 10/100 BaseT with auto MDIX. IEEE 802.3 TCP/IP Protocol. Dedicated port for Ethernet-based industrial protocol communications.
Dimensions	168.0mm (6.6in) x 110.0mm (4.3in)
Power Requirements	170 mA from PCIe bus +3.3VDC 240 mA from PCIe bus +12VDC
Power Consumption	3.5W (maximum)
Power Dissipation¹	9W (maximum)
Operating Temperature	0°C to 50°C (32°F to 122°F)
Storage Temperature	-40°C to 65°C (-40°F to 65°F)
Humidity	10% - 90%, non-condensing (Operating and Storage)
Regulatory Compliance	CE, FCC, KCC, RoHS

¹ Current flow through optically-isolated I/O will dissipate additional power.

Inputs

The Communication card features eight independent inputs (INPUTS 0 - 7), which can be used to trigger events. The inputs are optically isolated and typically connected (directly or indirectly) to a PLC or photoelectric sensor. The Communication card will respond to an event when the voltage difference between the INPUT and INPUT COMMON exceeds 10VDC. Refer to [Wire Inputs and Outputs on page 27](#) for common wiring configurations.

Note:



- There are two sets of inputs: INPUTS 0 - 3 share the INPUT COMMON 1 connection and INPUTS 4 - 7 share the INPUT COMMON 2 connection. Therefore the input devices for each set of inputs must be the same; either current sinking or current sourcing.
- To maintain optical isolation of the I/O lines, the devices connected to these lines must not be connected to the same power supply as the PC. If they are connected to, or share a ground with, the same power supply, they may still function but will no longer be optically isolated.

Specification	Description
Input Voltage Limit	24VDC
Voltage	Input ON: >10VDC Input OFF: < 2VDC
Current	Input ON: > 6mA Input OFF: < 1.5mA Each line is optically isolated and polarity-independent.

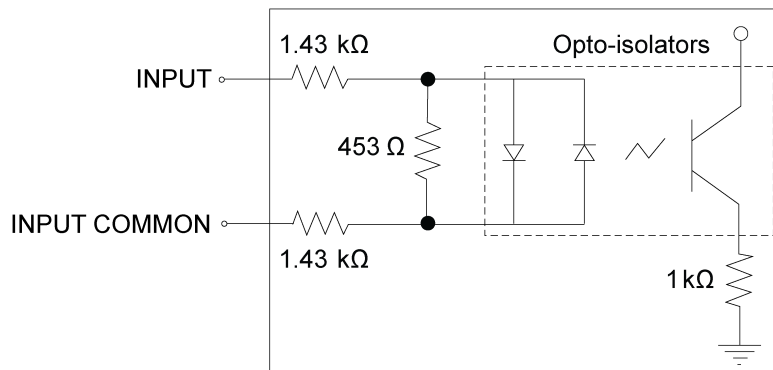

24VDC Max. across input pins - transition approx. 10VDC (Nom.)

Outputs

The Communication card features sixteen independent outputs (OUTPUTS 0 -15), which are optically isolated.

- OUTPUTS 0 - 7 provide up to 50mA current (maximum). These outputs are typically connected (directly or indirectly) to an input, such as a trigger input or PLC input.
- OUTPUTS 8 - 15 provide up to 100mA of current (maximum). These outputs are typically connected (directly or indirectly) to a load, such as a relay, indicator light or reject mechanism.

Refer to [Wire Inputs and Outputs on page 27](#) for common wiring configurations.

Note:



- There are four sets of outputs: OUTPUTS 0 - 3 share the OUTPUT COMMON 1 connection; OUTPUTS 4 - 7 share the OUTPUT COMMON 2 connection; OUTPUTS 8 - 11 share the OUTPUT COMMON 3 connection; and OUTPUTS 12 - 15 share the OUTPUT COMMON 4 connection. Therefore the output devices for each set of outputs must be the same; either current sinking or current sourcing.
- To maintain optical isolation of the I/O lines, the devices connected to these lines must not be connected to the same power supply as the PC. If they are connected to, or share a ground with, the same power supply, they may still function but will no longer be optically isolated.

OUTPUTS 0 - 7 Specifications:

Specification	Description
Voltage	24VDC maximum between an output and output common.
Current	50mA maximum. Each line protected against over-current, short circuit and reverse polarity.
Maximum Voltage Drop	3VDC @ 50mA
Delay ¹	25µs (maximum due to opto-isolators turning ON)

OUTPUTS 8 - 15 Specifications:

Specification	Description
Voltage	24VDC maximum between an output and output common.
Current	100mA maximum. Each line protected against over-current, short circuit and reverse polarity.
Maximum Voltage Drop	3.5VDC @ 100mA
Delay ²	25µs (maximum due to opto-isolators turning ON)

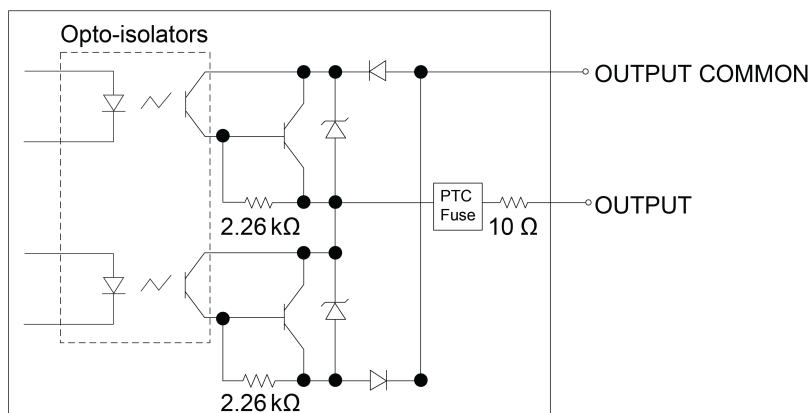

¹ Delay when opto-isolators turn OFF depends on the load to which the output is connected. With a 1K load, the maximum delay will be 500 µs.

² Delay when opto-isolators turn OFF depends on the load to which the output is connected. With a 1K load, the maximum delay will be 500 µs.

Encoder Inputs

The Communication card features four encoder inputs that can be used to connect to either a single-ended or differential encoder. Using an encoder allows you to specify input and output delay values in pulse counts instead of real time units. Refer to [Wire Inputs and Outputs on page 27](#) for common wiring configurations.

Note:

- Non-quadrature, single-channel encoders are not supported.
- The frequency of encoder pulses must not exceed 50 kHz.

Specification	Description
Differential Encoder	A+/B+: 5 to 24VDC A-/B-: Inverted (A+/B+)
Single-Ended Encoder	A+/B+: 5 to 24VDC A-/B-: VDC = 1/2 (A+/B+)
Maximum Encoder Frequency	50 kHz (maximum)

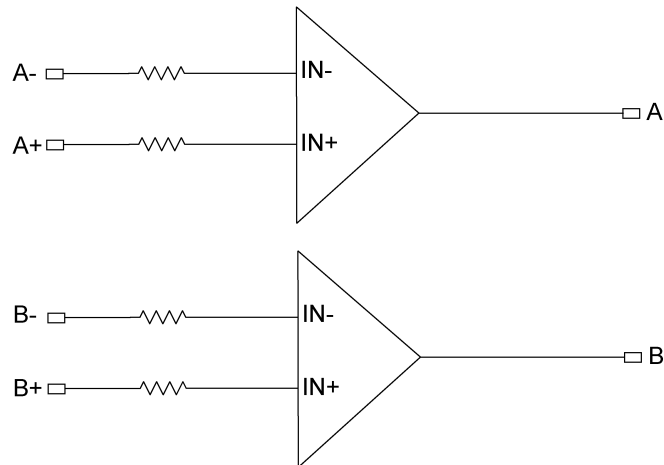

Channel A and B Inputs (5 to 24VDC, Non-differential or Differential)

I-ENET Port

The I-ENET port is a 10/100 RJ-45 Ethernet port that can be connected to a network that is dedicated to industrial Ethernet devices (for example, PLCs or robots) to communicate with the devices using supported industrial Ethernet protocols.

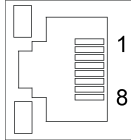

Pin Number	Signal Name
1	TRANSMIT+
2	TRANSMIT-
3	RECEIVE+
4	N/A
5	N/A
6	RECEIVE-
7	N/A
8	N/A

Mini Delta Ribbon Connector

The Mini Delta Ribbon (MDR) connector is a 36-pin connector that provides access to inputs, output and encoder lines via the Breakout cable or I/O Terminal Block cable.

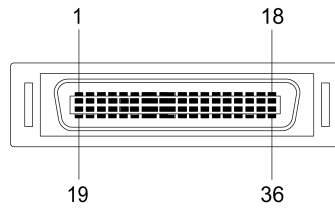

Pin Number	Signal Name
1	ENCODER A+
2	ENCODER A-
3	ENCODER GROUND
4	OUTPUT COMMON 4
5	OUTPUT 15
6	OUTPUT 14
7	OUTPUT 13
8	OUTPUT 12
9	OUTPUT 11
10	OUTPUT 10
11	OUTPUT 9
12	OUTPUT 8
13	OUTPUT COMMON 3
14	INPUT COMMON 2
15	INPUT 7
16	INPUT 6
17	INPUT 5
18	INPUT 4
19	ENCODER B+
20	ENCODER B-
21	NOT USED
22	OUTPUT COMMON 2
23	OUTPUT 7
24	OUTPUT 6
25	OUTPUT 5
26	OUTPUT 4
27	OUTPUT 3
28	OUTPUT 2
29	OUTPUT 1
30	OUTPUT 0
31	OUTPUT COMMON 1
32	INPUT COMMON 1

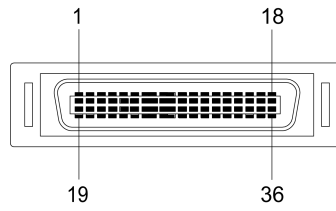

Pin Number	Signal Name
33	INPUT 3
34	INPUT 2
35	INPUT 1
36	INPUT 0

Breakout Cable Specifications

The Breakout cable provides access to the Communication card's input, output and encoder lines. The Breakout cable is not terminated.

Note:



- Cables are sold separately.
- Unused bare wires can be clipped short or tied back using a tie made of non-conductive material.

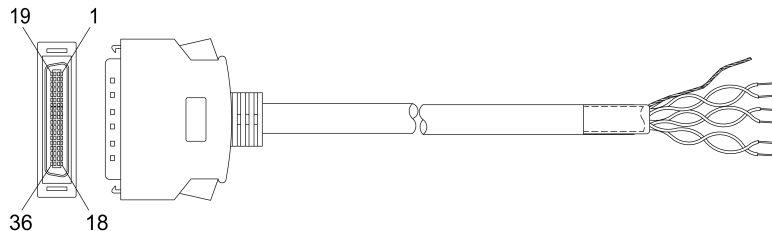

Pin Number	Signal Name	Wire Color
1	ENCODER A+	Black/Brown
2	ENCODER A-	Brown/Black
3	ENCODER GROUND	Black/Red
4	OUTPUT COMMON 4	Black/White
5	OUTPUT 15	Black/Green
6	OUTPUT 14	Black/Blue
7	OUTPUT 13	Black/Orange
8	OUTPUT 12	Red/White
9	OUTPUT 11	Red/Green
10	OUTPUT 10	Red/Blue
11	OUTPUT 9	Red/Yellow
12	OUTPUT 8	Red/Brown
13	OUTPUT COMMON 3	Red/Orange
14	INPUT COMMON 2	Green/White
15	INPUT 7	Green/Blue
16	INPUT 6	Green/Yellow
17	INPUT 5	Green/Brown
18	INPUT 4	Green/Orange
19	ENCODER B+	Black/Yellow
20	ENCODER B-	Yellow/Black
21	NOT USED	NOT USED
22	OUTPUT COMMON 2	White/Black
23	OUTPUT 7	Green/Black
24	OUTPUT 6	Blue/Black
25	OUTPUT 5	Orange/Black
26	OUTPUT 4	White/Red
27	OUTPUT 3	Green/Red

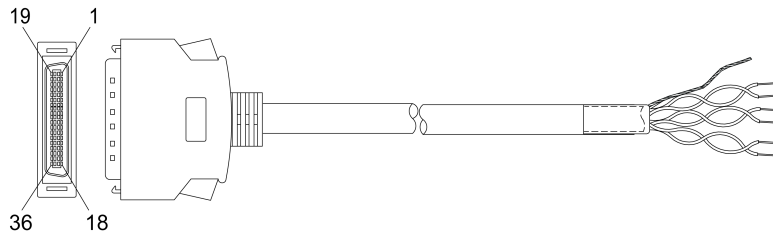

Pin Number	Signal Name	Wire Color
28	OUTPUT 2	Blue/Red
29	OUTPUT 1	Yellow/Red
30	OUTPUT 0	Brown/Red
31	OUTPUT COMMON 1	Orange/Red
32	INPUT COMMON 1	White/Green
33	INPUT 3	Blue/Green
34	INPUT 2	Yellow/Green
35	INPUT 1	Brown/Green
36	INPUT 0	Orange/Green
Shell	Shield	Bare Wire

I/O Terminal Block Cable Specifications

The I/O Terminal Block cable connects the Communication card directly to the Terminal Block accessory via the DB37 connector. When the Terminal Block accessory is used, all inputs, outputs and encoder lines used by the Communication card are connected using the I/O Terminal Block cable.

Note: Cables are sold separately.

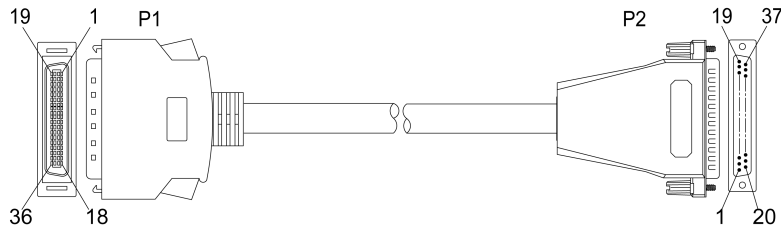

P1 Pin Number	Signal Name	P2 Pin Number
1	ENCODER A+	25
2	ENCODER A-	12
3	ENCODER GROUND	13
4	OUTPUT COMMON 4	35
5	OUTPUT 15	33
6	OUTPUT 14	32
7	OUTPUT 13	31
8	OUTPUT 12	30
9	OUTPUT 11	29
10	OUTPUT 10	28
11	OUTPUT 9	27
12	OUTPUT 8	26
13	OUTPUT COMMON 3	34
14	INPUT COMMON 2	10
15	INPUT 7	8
16	INPUT 6	7
17	INPUT 5	6
18	INPUT 4	5
19	ENCODER B+	24
20	ENCODER B-	11
21	NOT USED	36
22	OUTPUT COMMON 2	23
23	OUTPUT 7	21
24	OUTPUT 6	20
25	OUTPUT 5	19
26	OUTPUT 4	18
27	OUTPUT 3	17
28	OUTPUT 2	16
29	OUTPUT 1	15

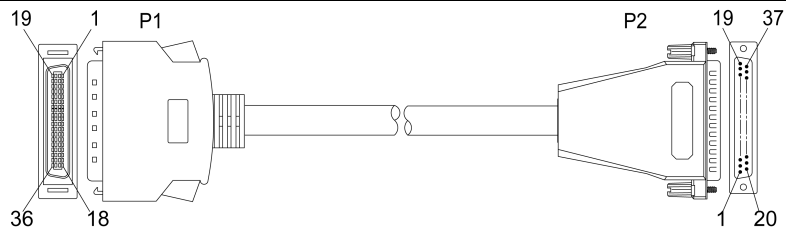

P1 Pin Number	Signal Name	P2 Pin Number
30	OUTPUT 0	14
31	OUTPUT COMMON 1	22
32	INPUT COMMON 1	9
33	INPUT 3	4
34	INPUT 2	3
35	INPUT 1	2
36	INPUT 0	1
N/A	NOT USED	37

Terminal Block Assignments

The DIN-rail mountable Terminal Block provides access to the Communication card's input, output and encoder lines. Recommended wiring is 12 - 24 AWG, solid or stranded wire.

CAUTION: The maximum torque that can be applied to the I/O terminal connectors is 0.5 Nm to 0.6 Nm (4.4 in-lb to 5.3 in-lb). Applying torque above this limit can damage the connectors.

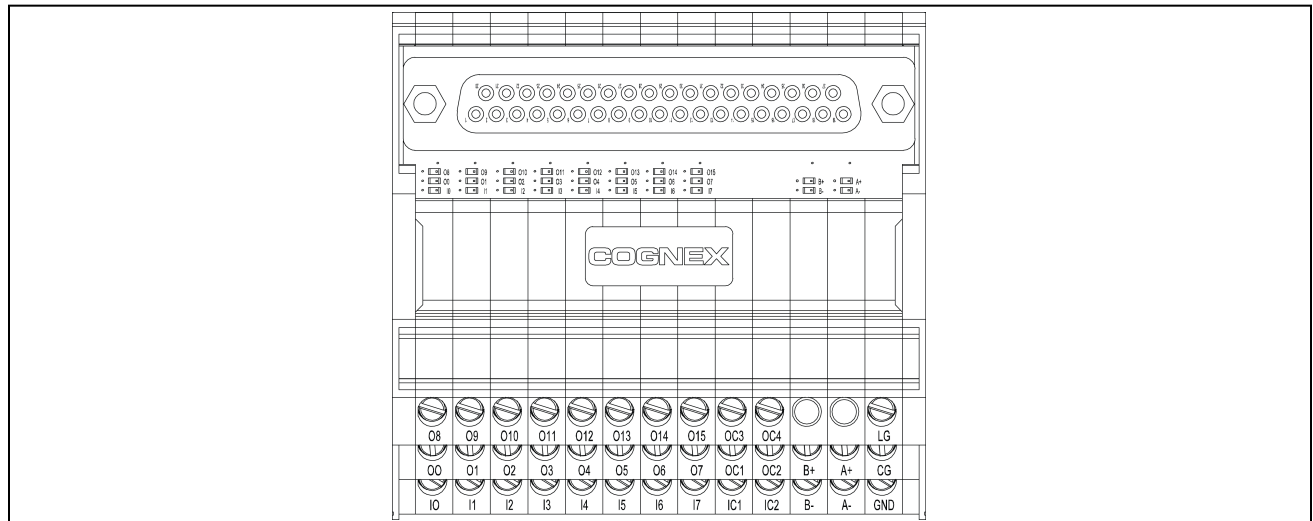

Pin Label	Signal Name	Pin Label	Signal Name	Pin Label	Signal Name
I0	INPUT 0	O0	OUTPUT 0	O8	OUTPUT 8
I1	INPUT 1	O1	OUTPUT 1	O9	OUTPUT 9
I2	INPUT 2	O2	OUTPUT 2	O10	OUTPUT 10
I3	INPUT 3	O3	OUTPUT 3	O11	OUTPUT 11
I4	INPUT 4	O4	OUTPUT 4	O12	OUTPUT 12
I5	INPUT 5	O5	OUTPUT 5	O13	OUTPUT 13
I6	INPUT 6	O6	OUTPUT 6	O14	OUTPUT 14
I7	INPUT 7	O7	OUTPUT 7	O15	OUTPUT 15
IC1	INPUT COMMON 1	OC1	OUTPUT COMMON 1	OC3	OUTPUT COMMON 3
IC2	INPUT COMMON 2	OC2	OUTPUT COMMON 2	OC4	OUTPUT COMMON 4
B-	ENCODER B-	B+	ENCODER B+	N/A	UNUSED
A-	ENCODER A-	A+	ENCODER A+	N/A	UNUSED
GND	ENCODER GROUND	CG	CHASSIS GROUND	LG	LED GROUND

Terminal Block LEDs

Each terminal pin has a corresponding LED. To use the LED indicators, the LED GROUND terminal must be connected to the ground (current sink) associated with the INPUT or OUTPUT lines. Each LED will light when 5VDC - 24VDC is present on the associated terminal pin.

CAUTION:



- If connecting the LED GROUND terminal, the OUTPUT COMMON pin(s) must be configured to source current (i.e., connected to +VDC) and the INPUT COMMON pin(s) must be configured to sink current (i.e., connected to -VDC).
- If any OUTPUT COMMON pin is connected to -VDC or any INPUT COMMON pin is tied to +VDC, the LED GROUND terminal should not be connected. Connecting the LED GROUND in these situations could lead to unexpected behavior on the INPUT and OUTPUT lines.

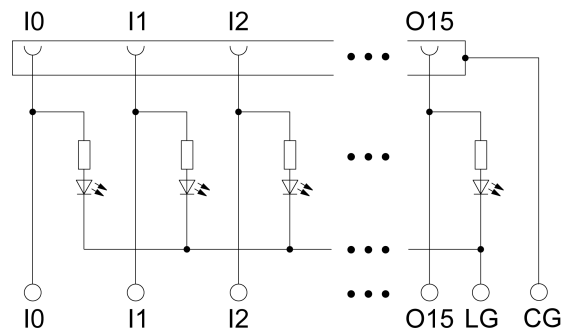

Communication Card Dimensions

The Communication card is a short length PCIe card, occupying a single x1 PCIe bus slot.

Note:

- All dimensions are in millimeters [inches] and are for reference purposes only.
- All specifications are for reference purpose only and may be changed without notice.

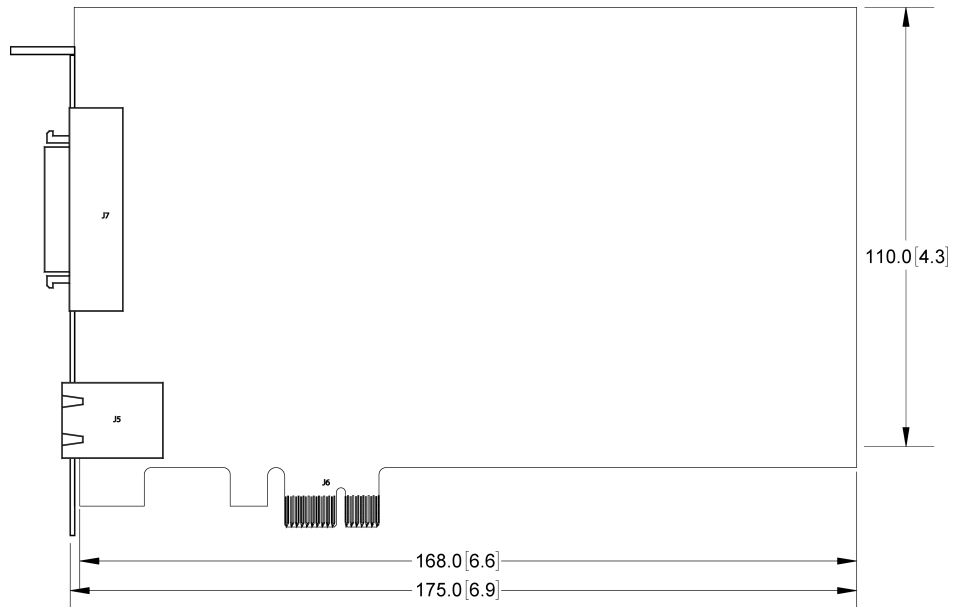

Wire Inputs and Outputs

The following figures show basic wiring for some of the more common I/O configurations.

Input from PLC - Current Sinking

To configure the input as a sinking input, connect INPUT COMMON (for example, INPUT COMMON 1) to the high voltage reference (+24VDC) and connect one of the INPUTS (for example, INPUT 0) to the OUTPUT of the photoelectric sensor or PLC. When the PLC output turns ON, the INPUT is pulled down to a low voltage level.

Note:

- The inputs are typically connected (directly or indirectly) to a PLC or photoelectric sensor.
- There are two sets of inputs: INPUTS 0 - 3 share the INPUT COMMON 1 connection and INPUTS 4 - 7 share the INPUT COMMON 2 connection. Therefore the input devices for each set of inputs must be the same; either current sinking or current sourcing.
- To maintain optical isolation of the I/O lines, the devices connected to these lines must not be connected to the same power supply as the PC. If they are connected to, or share a ground with, the same power supply, they may still function but will no longer be optically isolated.

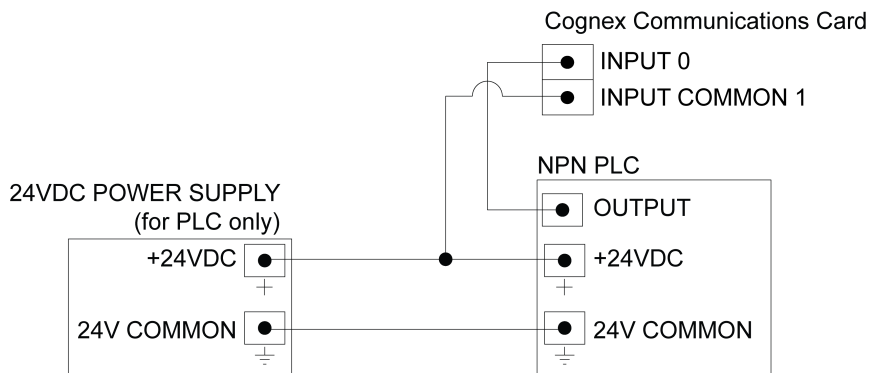

Input from PLC - Current Sourcing

To configure the input as sourcing input, connect INPUT COMMON (for example, INPUT COMMON 1) to the low voltage reference (24V COMMON) and one of the INPUTS (for example, INPUT 0) to the OUTPUT of the photoelectric sensor or PLC. When the PLC output turns ON, the INPUT is pulled up to a positive voltage level.

Note:

- The inputs are typically connected (directly or indirectly) to a PLC or photoelectric sensor.
- There are two sets of inputs: INPUTS 0 - 3 share the INPUT COMMON 1 connection and INPUTS 4 - 7 share the INPUT COMMON 2 connection. Therefore the input devices for each set of inputs must be the same; either current sinking or current sourcing.
- To maintain optical isolation of the I/O lines, the devices connected to these lines must not be connected to the same power supply as the PC. If they are connected to, or share a ground with, the same power supply, they may still function but will no longer be optically isolated.

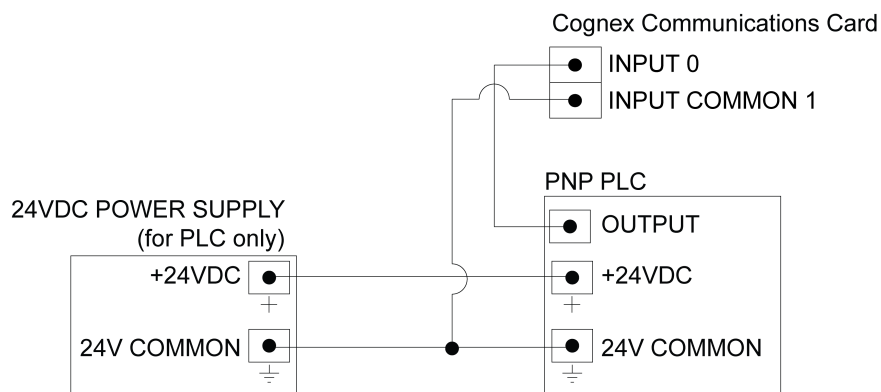

Output to PLC - Current Sinking

To configure the output as a sinking output, connect OUTPUT COMMON (for example, OUTPUT COMMON 2) to the low voltage reference (24V COMMON) and connect one of the OUTPUTS (for example, OUTPUT 4) to the INPUT of the photoelectric sensor or PLC. When the output turns ON, the PLC input is pulled down to a low voltage level.

Note:

- OUTPUTS 0 - 7 provide up to 50mA current (maximum). These outputs are typically connected (directly or indirectly) to an input, such as a trigger input or PLC input.
- There are four sets of outputs: OUTPUTS 0 - 3 share the OUTPUT COMMON 1 connection; OUTPUTS 4 - 7 share the OUTPUT COMMON 2 connection; OUTPUTS 8 - 11 share the OUTPUT COMMON 3 connection; and OUTPUTS 12 - 15 share the OUTPUT COMMON 4 connection. Therefore the output devices for each set of outputs must be the same; either current sinking or current sourcing.
- To maintain optical isolation of the I/O lines, the devices connected to these lines must not be connected to the same power supply as the PC. If they are connected to, or share a ground with, the same power supply, they may still function but will no longer be optically isolated.

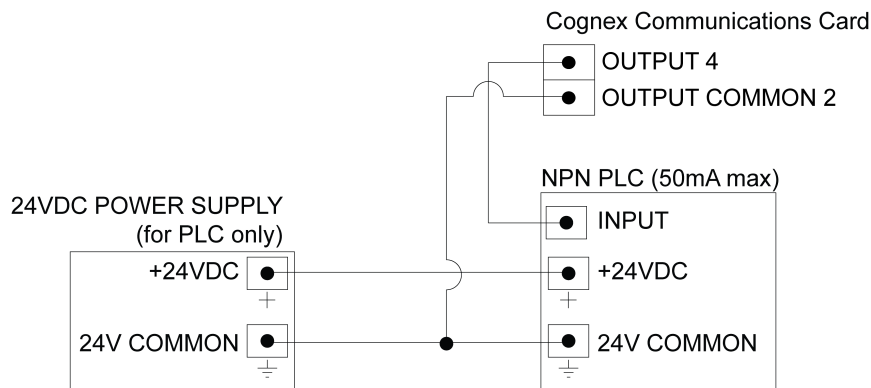

Output to PLC - Current Sourcing

To configure the output as a sourcing output, connect OUTPUT COMMON (for example, OUTPUT COMMON 2) to the high voltage reference (+24VDC) and connect one of the OUTPUTS (for example, OUTPUT 4) to the INPUT of the photoelectric sensor or PLC. When the output turns ON, the PLC input is pulled up to a high voltage level.

Note:

- OUTPUTS 0 - 7 provide up to 50mA current (maximum). These outputs are typically connected (directly or indirectly) to an input, such as a trigger input or PLC input.
- There are four sets of outputs: OUTPUTS 0 - 3 share the OUTPUT COMMON 1 connection; OUTPUTS 4 - 7 share the OUTPUT COMMON 2 connection; OUTPUTS 8 - 11 share the OUTPUT COMMON 3 connection; and OUTPUTS 12 - 15 share the OUTPUT COMMON 4 connection. Therefore the output devices for each set of outputs must be the same; either current sinking or current sourcing.
- To maintain optical isolation of the I/O lines, the devices connected to these lines must not be connected to the same power supply as the PC. If they are connected to, or share a ground with, the same power supply, they may still function but will no longer be optically isolated.

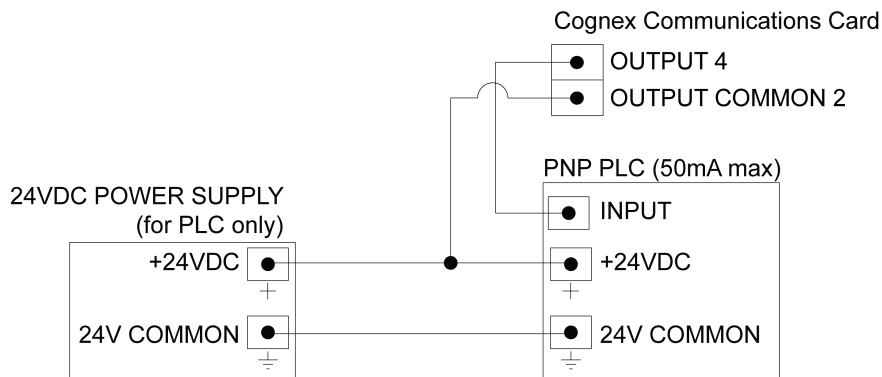

Output to Pilot Light - Current Sinking

To configure the output as a sinking output, connect OUTPUT COMMON (for example, OUTPUT COMMON 4) to the power supply's low voltage reference (24V COMMON) and connect one of the OUTPUTS (for example, OUTPUT 12) to the pilot light's low voltage reference (24V COMMON).

Note:

- OUTPUTS 8 - 15 provide up to 100mA of current (maximum). These outputs are typically connected (directly or indirectly) to a load, such as a relay, indicator light or reject mechanism.
- There are four sets of outputs: OUTPUTS 0 - 3 share the OUTPUT COMMON 1 connection; OUTPUTS 4 - 7 share the OUTPUT COMMON 2 connection; OUTPUTS 8 - 11 share the OUTPUT COMMON 3 connection; and OUTPUTS 12 - 15 share the OUTPUT COMMON 4 connection. Therefore the output devices for each set of outputs must be the same; either current sinking or current sourcing.
- To maintain optical isolation of the I/O lines, the devices connected to these lines must not be connected to the same power supply as the PC. If they are connected to, or share a ground with, the same power supply, they may still function but will no longer be optically isolated.

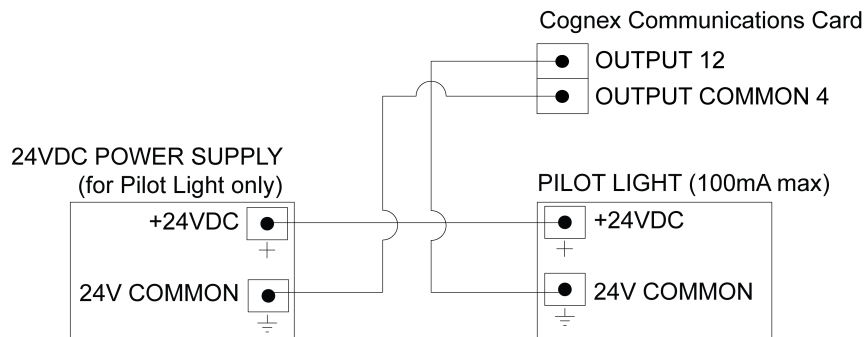

Output to Pilot Light - Current Sourcing

To configure the output as a sourcing output, connect OUTPUT COMMON (for example, OUTPUT COMMON 4) to the power supply's high voltage reference (+24VDC) and connect one of the OUTPUTS (for example, OUTPUT 12) to the pilot light's high voltage reference (+24VDC).

Note:

- OUTPUTS 8 - 15 provide up to 100mA of current (maximum). These outputs are typically connected (directly or indirectly) to a load, such as a relay, indicator light or reject mechanism.
- There are four sets of outputs: OUTPUTS 0 - 3 share the OUTPUT COMMON 1 connection; OUTPUTS 4 - 7 share the OUTPUT COMMON 2 connection; OUTPUTS 8 - 11 share the OUTPUT COMMON 3 connection; and OUTPUTS 12 - 15 share the OUTPUT COMMON 4 connection. Therefore the output devices for each set of outputs must be the same; either current sinking or current sourcing.
- To maintain optical isolation of the I/O lines, the devices connected to these lines must not be connected to the same power supply as the PC. If they are connected to, or share a ground with, the same power supply, they may still function but will no longer be optically isolated.

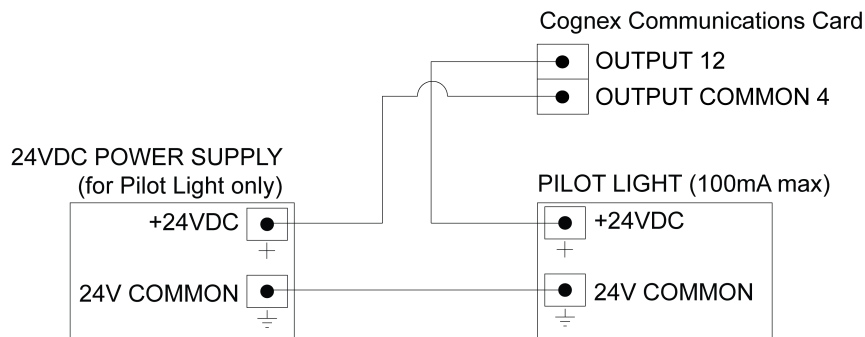

Differential Encoder Configuration

For a differential encoder, connect A+, B+, A- and B- to the corresponding encoder outputs. Connect the encoder's ground wire to ENCODER GROUND.

Note:

- Non-quadrature, single-channel encoders are not supported.
- The frequency of encoder pulses must not exceed 50 kHz.

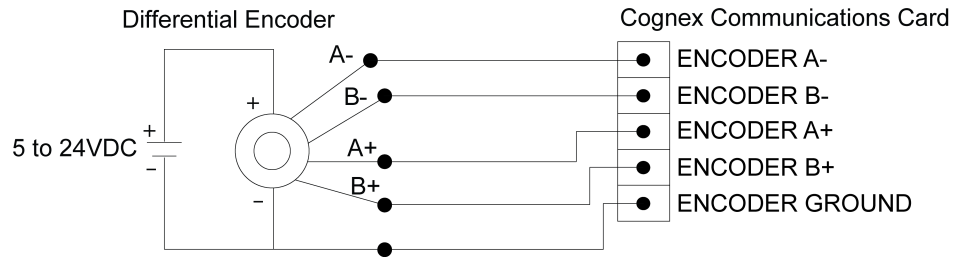

Single-Ended Encoder Configuration

For a single-ended encoder, connect A+ and B+ to the corresponding encoder outputs. Derive A- and B- from the encoder voltage source and make them equal to 50% of the encoder reference voltage (for example, if the encoder is connected to 24VDC, set A- and B- to 12VDC). Connect the encoder's ground wire to ENCODER GROUND.

Note:



- Non-quadrature, single-channel encoders are not supported.
- The frequency of encoder pulses must not exceed 50 kHz.

