

# **VisionPro<sup>®</sup>** **Trevista CI Dome** **Installation and Operation**

2024 October 31

Revision: 9.22.0-SR1.4



# Legal Notices

The software described in this document is furnished under license, and may be used or copied only in accordance with the terms of such license and with the inclusion of the copyright notice shown on this page. Neither the software, this document, nor any copies thereof may be provided to, or otherwise made available to, anyone other than the licensee. Title to, and ownership of, this software remains with Cognex Corporation or its licensor. Cognex Corporation assumes no responsibility for the use or reliability of its software on equipment that is not supplied by Cognex Corporation. Cognex Corporation makes no warranties, either express or implied, regarding the described software, its merchantability, non-infringement or its fitness for any particular purpose.

The information in this document is subject to change without notice and should not be construed as a commitment by Cognex Corporation. Cognex Corporation is not responsible for any errors that may be present in either this document or the associated software.

Companies, names, and data used in examples herein are fictitious unless otherwise noted. No part of this document may be reproduced or transmitted in any form or by any means, electronic or mechanical, for any purpose, nor transferred to any other media or language without the written permission of Cognex Corporation.

Copyright © 2023. Cognex Corporation. All Rights Reserved.

Portions of the hardware and software provided by Cognex may be covered by one or more U.S. and foreign patents, as well as pending U.S. and foreign patents listed on the Cognex web site at: [cognex.com/patents](https://cognex.com/patents).

---

The following are registered trademarks of Cognex Corporation:

Cognex, 2DMAX, Advantage, AlignPlus, Assemblyplus, Check it with Checker, Checker, Cognex Vision for Industry, Cognex VSOC, CVL, DataMan, DisplayInspect, DVT, EasyBuilder, Hotbars, IDMax, In-Sight, Laser Killer, MVS-8000, OmniView, PatFind, PatFlex, PatInspect, PatMax, PatQuick, SensorView, SmartView, SmartAdvisor, SmartLearn, UltraLight, Vision Solutions, VisionPro, VisionView

The following are trademarks of Cognex Corporation:

The Cognex logo, 1DMax, 3D-Locate, 3DMax, BGAll, CheckPoint, Cognex VSoC, CVC-1000, FFD, iLearn, In-Sight (design insignia with cross-hairs), In-Sight 2000, InspectEdge, Inspection Designer, MVS, NotchMax, OCRMax, PatMax RedLine, ProofRead, SmartSync, ProfilePlus, SmartDisplay, SmartSystem, SMD4, VisiFlex, Xpand

Portions copyright © Microsoft Corporation. All rights reserved.

Portions copyright © MadCap Software, Inc. All rights reserved.

Other product and company trademarks identified herein are the trademarks of their respective owners.

# Precautions

To reduce the risk of injury or equipment damage, observe the following precautions when you install the Cognex product:

- Trevista Controller requires power supply connection from a supply network that meets the following requirements:  
100-240 V AC +/- 1-%, 50-60 Hz, 550 VA
- This product is intended for industrial use in automated manufacturing or similar applications.
- The safety of any system incorporating this product is the responsibility of the assembler of the system.
- Do not install Cognex products where they are exposed to environmental hazards such as excessive heat, dust, moisture, humidity, impact, vibration, corrosive substances, flammable substances, or static electricity.
- Route cables and wires away from high-current wiring or high-voltage power sources to reduce the risk of damage or malfunction from the following causes: over-voltage, line noise, electrostatic discharge (ESD), power surges, or other irregularities in the power supply.
- Do not expose the image sensor to laser light. Image sensors can be damaged by direct, or reflected, laser light. If your application requires laser light that might strike the image sensor, use a lens filter at the corresponding laser wavelength. For suggestions, contact your local integrator or application engineer.
- This product does not contain user-serviceable parts. Do not make electrical or mechanical modifications to product components. Unauthorized modifications can void your warranty.
- Changes or modifications not expressly approved by the party responsible for regulatory compliance could void the user's authority to operate the equipment.
- Include service loops with cable connections.
- Ensure that the cable bend radius begins at least six inches from the connector. Cable shielding can be degraded or cables can be damaged or wear out faster if a service loop or bend radius is tighter than 10X the cable diameter.
- This device should be used in accordance with the instructions in this manual.
- All specifications are for reference purposes only and can change without notice.

# Symbols

The following symbols indicate safety precautions and supplemental information:

---

 **WARNING:** This symbol indicates a hazard that could cause death, serious personal injury or electrical shock.

---

---

 **CAUTION:** This symbol indicates a hazard that could result in property damage.

---

---

 **Note:** This symbol indicates additional information about a subject.

---

---

 **Tip:** This symbol indicates suggestions and shortcuts that might not otherwise be apparent.

---

# Table of Contents

<b>Legal Notices</b> .....	<b>3</b>
<b>Precautions</b> .....	<b>4</b>
<b>Symbols</b> .....	<b>5</b>
<b>Table of Contents</b> .....	<b>6</b>
<b>About the Trevista Controller and Dome Light</b> .....	<b>9</b>
Important Notes .....	9
Components .....	9
Trevista Dome Lights .....	10
Accessories .....	11
Spare Parts .....	12
<b>Safety</b> .....	<b>13</b>
Intended Use .....	13
Residual Risks .....	13
Residual Risks During Installation .....	13
Residual Risks During Operation .....	13
<b>Technical Data</b> .....	<b>14</b>
General Data .....	14
Mechanical Data .....	14
Operating Environment .....	14
Optical Radiation .....	15
Supply of External Devices .....	15
Maximum Temperature .....	15
Cable Bending Radii .....	15
Dimensional Drawings .....	15
Trevista CI Dome S .....	16
Trevista CI Dome M .....	16
Trevista CI Dome L .....	17
Controller .....	18
Camera Adapter Plate .....	18
Camera Angle .....	20
Timing Diagrams .....	21
Trevista CI Dome .....	21
Trevista CI Dome Scan .....	22
Direction of Illumination Progression .....	23
Trevista CI Dome/Trevista CI Dome Scan .....	23
Trevista CI Dome/Trevista CI Dome Scan Multiline .....	24
<b>Layouts</b> .....	<b>26</b>
Trevista CI Dome Layouts .....	26
Trevista CI Dome S .....	26
Trevista CI Dome M .....	27
Trevista CI Dome L .....	28
Controller Layouts .....	29

Front Panel .....	29
Rear Panel .....	29
<b>Installation .....</b>	<b>31</b>
Mounting .....	31
Mounting the Controller .....	31
Mounting the Dome .....	31
Mounting the Camera .....	32
Camera Orientation .....	32
Cabling .....	33
Cabling Variants .....	33
Power Supply .....	35
<b>Device Mode and Functional Groups .....</b>	<b>37</b>
Device Mode .....	37
Area Scan .....	37
Line Scan .....	39
Functional Groups .....	40
Light/Camera I/O 1 + 2 .....	40
Sequencer .....	40
<b>Controller Interfaces .....</b>	<b>42</b>
Ethernet .....	42
Camera I/O .....	42
Basic Circuit .....	42
Pin Assignment .....	43
Connection Example .....	44
Sequencer Control .....	44
Camera Trigger .....	44
Electrical Data .....	45
Aux I/O .....	46
Basic Circuit .....	46
Pin Assignment .....	47
Connection Example .....	49
Electrical Data .....	50
Digital I/O .....	51
Basic Circuit .....	52
Pin Assignment .....	53
Connection Example .....	54
Electrical Data .....	56
Encoder .....	57
Basic Circuit .....	57
Pin Assignment .....	58
Connection Example .....	58
Electrical Data .....	59
Light .....	60
Light 0 .....	60
Light 1 and Light 2 .....	60
Training Sequence .....	61

Current and Voltage Monitoring .....	62
Basic Circuit .....	62
Pin Assignment .....	63
Connection Example .....	65
<b>Operation .....</b>	<b>66</b>
Block Diagram .....	66
Power On/Off .....	66
Manual Operation of the Dome .....	67
LEDs .....	67
Display .....	69
Standard Display .....	70
Error and Warning Notifications .....	70
Menu .....	71
Notification Types .....	71
Network Operation of the Dome .....	77
Image-Processing Software SAC VisionPro® .....	78
SAC Device Configurator .....	78
<b>Care and Maintenance .....</b>	<b>80</b>
Cleaning .....	80
Replacing the Fuses .....	80
<b>Regulations and Conformity .....</b>	<b>82</b>
中国大陆 RoHS (Information for China RoHS Compliance) .....	82
For European Community Users .....	83

# About the Trevista Controller and Dome Light

This installation and operation manual is intended to make it easier for you to use and operate the Trevista Controller and Dome Light.

The Trevista CI Dome system is constantly improved and developed further. These product changes are also reflected in the product documentation.

This Operation and Installation Manual applies to the following device version of the Dome controller

- Hardware version: 2
- Mainboard version: 1
- Firmware version: V2.36

The current hardware, mainboard, and firmware versions of the Dome controller can be found in the device display.

**i Note:** The image processing system must only be mounted (installed) by an electrician or by instructed personnel.

## Important Notes

- This installation and operation manual must always be available to the personnel in charge of the installation and to future operators.
- This installation and operation manual is intended to make it easier for you to
  - get to know Trevista CI Dome,
  - use Trevista CI Dome as intended,
  - operate Trevista CI Dome.
- Read this installation and operation manual carefully. It contains important notes on how to use Trevista CI Dome
  - safely and
  - properly.
- Compliance with the warning notices and special notes is mandatory to guarantee
  - the safety of the operating personnel,
  - the prevention of dangerous conditions (work accidents),
  - the proper operation of Trevista CI Dome.
- We do not accept any liability for damage or operating failures resulting from non-compliance with this original installation and operation manual.

## Components

Acquiring an image with the Trevista CI Dome and passing it to VisionPro software requires you have all of the following:

- Trevista CI Dome  
Cognex offers small, medium and large versions of the Dome Light.

- Camera mount

The camera mount allows you to secure the camera over the center of the Dome Light.

- Trevista controller

A Dome Light requires a controller as the interface between the light, the camera, and VisionPro software.

- Area scan camera or line scan camera

VisionPro supports a set cameras for use with a Trevista CI Dome. Choose a lens with a focal length to match the working distance and desired field of view.

Contact your Cognex sales representative for the best area scan camera for your applications.

- VisionPro software

VisionPro supports an acquisition module for acquiring images and the vision tool necessary to select which output images you want to pass along to your application.

## Trevista Dome Lights

Contact your Cognex sales representative for more information on any Trevista CI Dome:

- Accessory Model 50237: S-dome 20.4

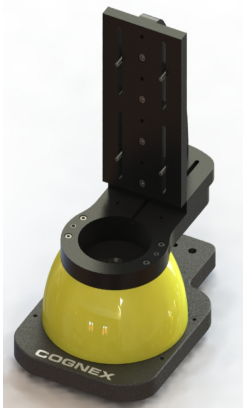

- Accessory Model 50238: M-dome 50.4



- Accessory Model 50239: L-dome 200.4

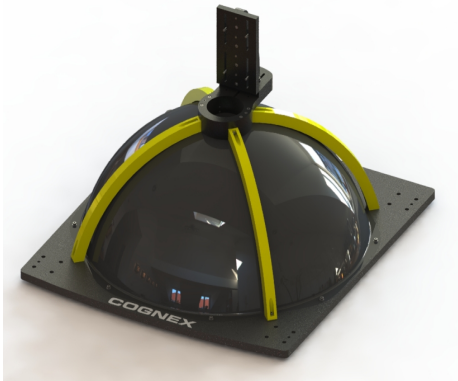

## Accessories

You can purchase the following components separately. For a list of options and accessories, contact your local Cognex sales representative.

Accessory	Length	Trevista CI Dome Area Scan	Trevista CI Dome Line Scan
Cable "trevista® Camera AV1" (trevista® controller <-> camera), For Allied Vision Prosilica GT, Prosilica GX, Pike, and Stingray.	5 m 10 m	x	
Cable "trevista® Camera AV2" (trevista® controller <-> camera), For Allied Vision Mako.	5 m 10 m	x	
Cable "trevista® Camera Baumer 1" (trevista® controller <-> camera), For Baumer SXG and VCXG.	5 m 10 m	x	
Cable "trevista® Camera Baumer 2" (trevista® controller <-> camera), For Baumer TXG, TXD, and TXF.	5 m 10 m	x	
Cable "trevista® Camera Baumer 3" (trevista® controller <-> camera), For Baumer VLG.	5 m 10 m	x	
Cable "trevista® Camera Baumer 3Y" (trevista® controller <-> 2x camera), For 2x Baumer VLG (Y-cable).	5 m	x	
Cable "trevista® Camera Baumer 4" (trevista® controller <-> camera), For Baumer VLXT.	5 m 10 m	x	
Cable "trevista® Camera Dalsa" (trevista® controller <-> camera, power supply) For Dalsa Piranha, Piranha 2, Piranha 3, Piranha 4, Piranha HS, Spyder 3, Spyder 3 SG, and Linea CL.	5 m 10 m		x
Cable "trevista® Camera Dalsa 2" (trevista® controller <-> camera) For Dalsa Linea GigE.	5 m 10 m		x
Cable "trevista® Camera Hikrobot 1" (trevista® controller <-> camera) For Hikrobot MV-CL022-91GM, MV-CL042-90GM, MV-CL042-91GM, MV-CL084-91GM, MV-CL042-91CM, and MV-CL084-90CM.	5 m		x
Cable "trevista® Camera", open cable end (trevista® controller <-> camera)	10 m	x	x

Cable "trevista® Aux I/O Siso" (trevista® controller <-> framegrabber "Silicon Software TTL Trigger 4")	1 m	x	x
Cable "trevista® Aux I/O Euresys 1" (trevista® controller <-> framegrabber "Euresys Grablink Full / FullXR")	1 m	x	x
Cable "trevista® Aux I/O", open cable end (trevista® controller <-> framegrabber)	1 m	x	x
Cable "trevista® Digital I/O", open cable end (trevista® controller <-> control cabinet/PLC)	10 m	x	x
Cable "trevista® Digital I/O", ICPDAS (trevista® controller <-> I/O card from ICPDAS)	1 m	x	x
Cable "trevista® Sync" (trevista® controller <-> trevista® controller)	0.5 m	x	x
Cable "trevista® Camera I/O Sync" (trevista® controller <-> trevista® controller)	1 m	x	x

**Spare Parts**

Accessory	SAC Article Number
Air filter	GEH-00338
Fuse T 5A H 250 V (two pieces required)	EIM-00076

# Safety

## Intended Use

- The image-processing system Trevista CI Dome is intended for the optical control of the surface quality of industrial components. Any other use shall be deemed inappropriate. The manufacturer/supplier is not liable for damage caused by such inappropriate use. The risk is borne solely by the user.
- The intended use includes compliance with the original installation and operation manual.
- The image-processing system Trevista CI Dome must only be installed and operated by qualified and trained personnel.

## Residual Risks

The image-processing system Trevista CI Dome has been built using state-of-the-art technology in accordance with recognized safety regulations. Compliance with the relevant occupational safety and accident prevention regulations is assumed. However, there are the following residual risks:

### Residual Risks During Installation

---

**⚠ WARNING:** Personal injuries and damage to property through residual voltages! Prior to working on the electrical system, make sure that the device has been disconnected from the power supply.

---

**⚠ WARNING:** Personal injury through optical radiation! Prior to installation and maintenance work, make sure that the device has been disconnected from the power supply. Do not look directly into the inside of the dome or into the LEDs.

---

**⚠ WARNING:** Personal injury through heat! Prior to installation and maintenance work, make sure that the device has cooled down.

---

### Residual Risks During Operation

---

**⚠ WARNING:** Personal injury through optical radiation! Prior to installation and maintenance work, make sure that the device has been disconnected from the power supply. Do not look directly into the inside of the dome or into the LEDs.

---

**⚠ WARNING:** Personal injury through heat! Before touching the lighting, make sure that the device has cooled down.

---

# Technical Data

Refer to the following sections for technical data regarding the Trevista CI Dome.

## General Data

Dimensions for Image Processing			
	Trevista CI Dome S	Trevista CI Dome M	Trevista CI Dome L
Working distance between lens and inspection plane	Typical 72 mm (2.83 in)	Typical 158 mm (6.22 in)	Typical. 300 mm (11.81 in)
Working distance between bottom edge and inspection plane	Typical 2 mm (0.08 in)	Typical 10 mm (0.39 in)	Typical 47 mm (1.85 in)
Diameter of measuring field/scan width <sup>1</sup>	Up to 30 mm (1.18 in)	Up to 75 mm (2.95 in)	Up to 300 mm (11.81 in)

<sup>1</sup> Depending on the camera, optics, and the surface properties of the inspection part.

## Mechanical Data

Dimensions Width × Depth × Height (Without Plugs and Cables)			
	Trevista CI Dome S	Trevista CI Dome M	Trevista CI Dome L
Dome	246 mm x 160 mm x typical 259 mm (9.69 in x 6.30 in x typical 10.20 in)	388 mm x 330 mm x typical 348 mm (15.26 in x 13.00 in x typical 13.70 in)	669 mm x 610 mm x typical 453 mm (26.33 in x 24.02 in x typical 17.83 in)
Controller	484 mm x 44 mm x 370 mm		
Weight			
Dome	4.1 kg (9.04 lb)	6.9 kg (15.21 lb)	16.2 kg (35.71 lb)
Controller	6.4 kg (14.11 lb)		
Material			
Dome	Aluminum/plastic		
Controller	Aluminum-zinc		

## Operating Environment

Electrical Power Supply	100-240 V AC +/- 10%, 50-60 Hz, 550 VA
Installation Site	Dry interiors
Ambient Temperature	+5 °C ... +40 °C (41 °F ... 104 °F)
Relative Humidity	40 ... 70 %
Height	maximum 2000 m (6561.68 ft)
Degree of Contamination	2
Overvoltage Category	2

## Optical Radiation

Light Source	
Risk Group	1 (low risk)

## Supply of External Devices

You can power external devices through the following connectors:

- Camera I/O 0..2
- Digital I/O
- Encoder

For more information about pin assignment and current-carrying capacity of the individual connections, see [Controller Interfaces on page 42](#). The maximum current-carrying capacity of all connections together exceeds the maximum possible capacity of the controller.

The following table shows the maximum power through all supply rails and the maximum current of the individual supply rails.

5/12/24 V Supply Rail	
Max. power over all supply rails	75 W
Max. current 24 V supply rail	3 A
Max. current 12 V supply rail	4 A
Max. current 5 V supply rail	1 A

## Maximum Temperature

Maximum Surface Temperature During Operation	
Controller	70 °C (158 °F)
Dome	70 °C (158 °F)

## Cable Bending Radii

Trevista CI Dome Type	Unmoved	Moved
Connection Cable Trevista CI Dome S	≥ 36 mm (1.41 in)	≥ 67.5 mm (2.66 in)
Connection Cable Trevista CI Dome M	≥ 66 mm (2.60 in)	≥ 132 mm (5.20 in)
Connection Cable Trevista CI Dome L	≥ 66 mm (2.60 in)	≥ 132 mm (5.20 in)

## Dimensional Drawings

The following sections list dimensions of the Trevista CI Dome and accessories.

## Trevista CI Dome S

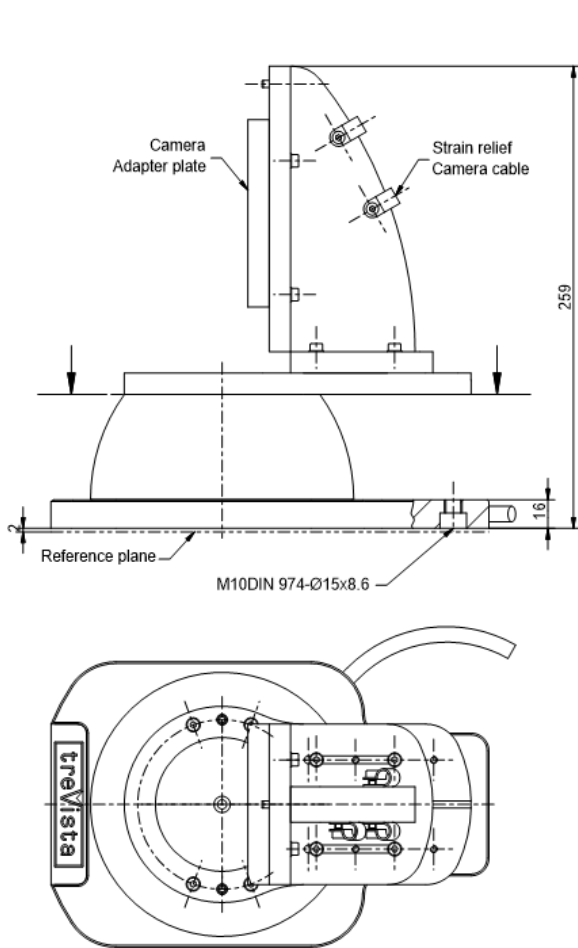

X1 (View without camera mount)

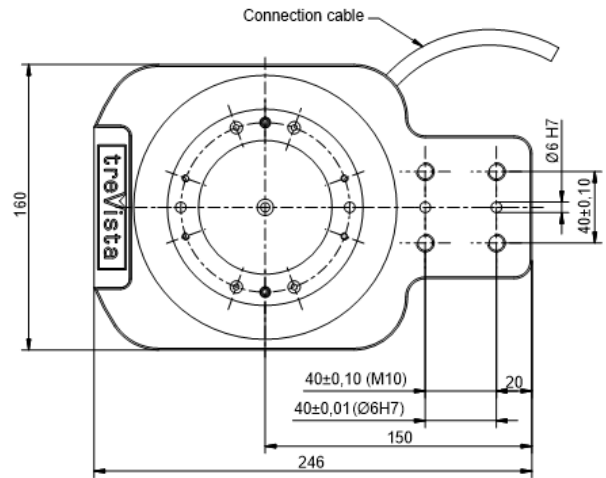

X2 (View with rotated camera mount)

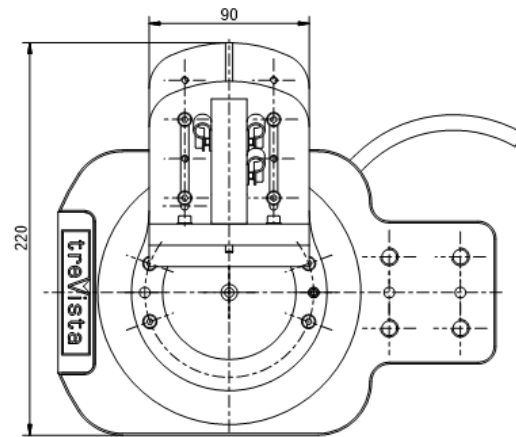

## Trevista CI Dome M

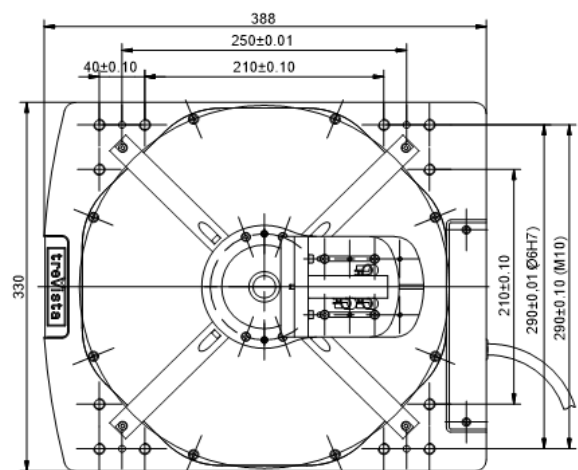
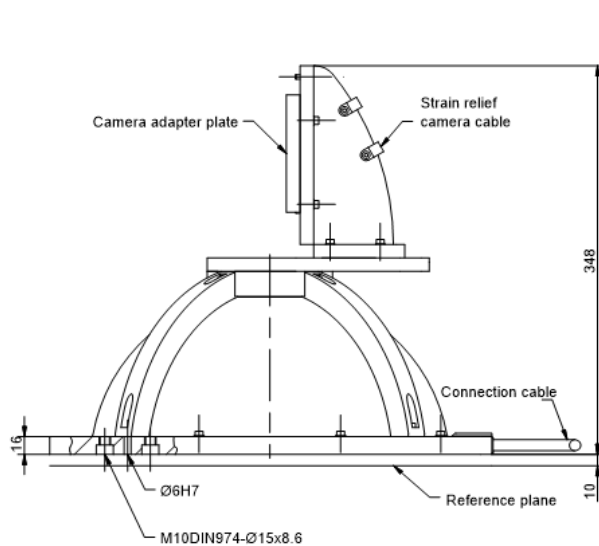

# Trevista CI Dome L

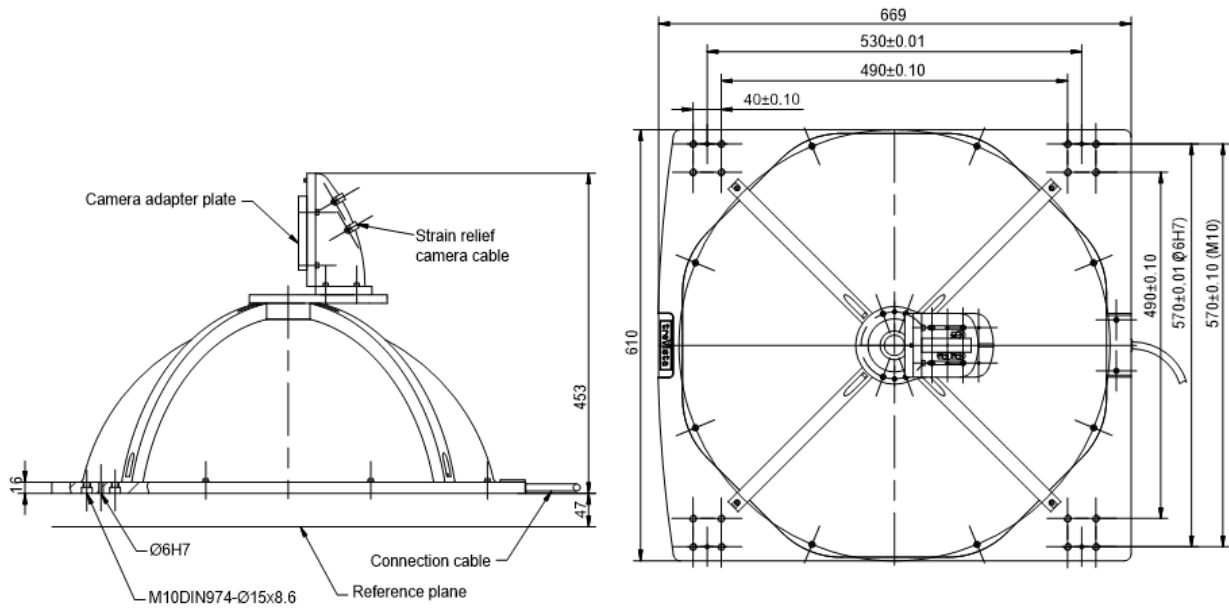

## Controller

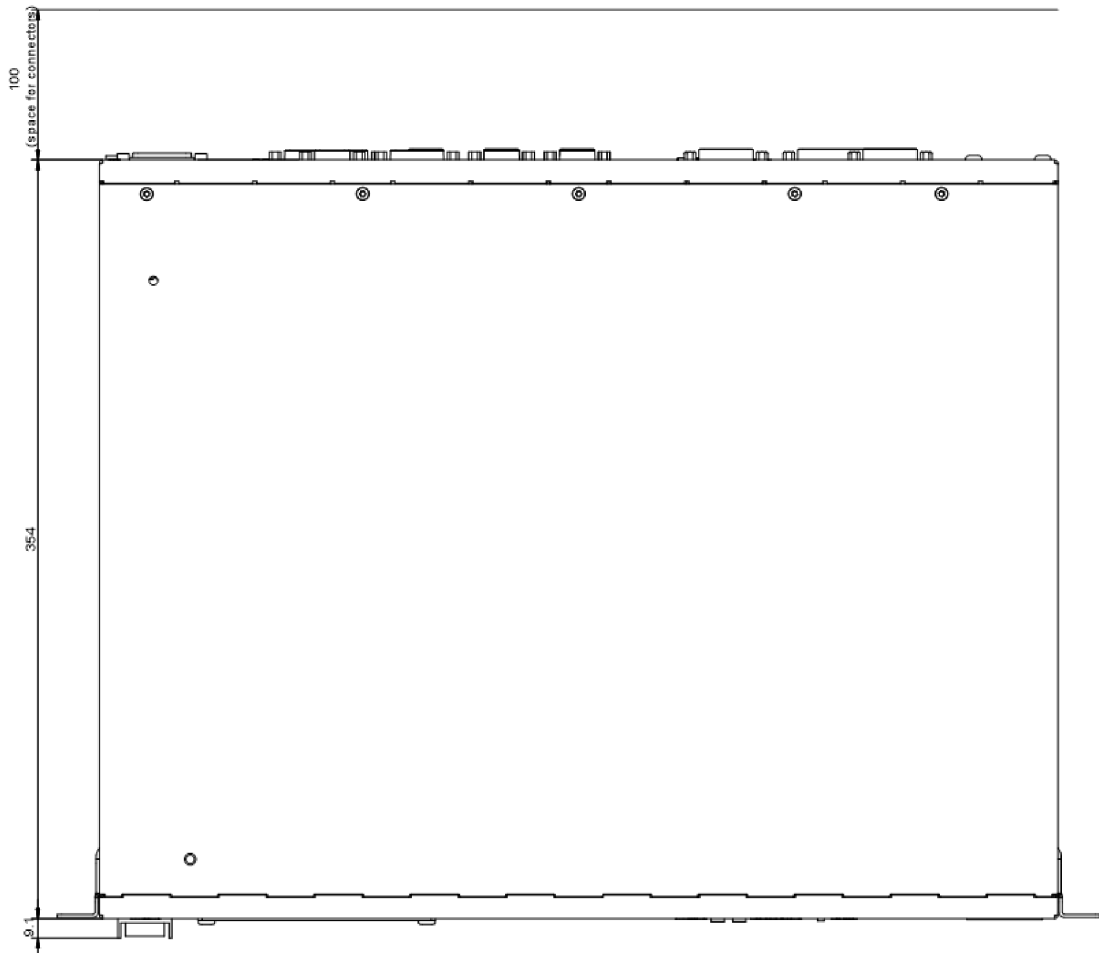
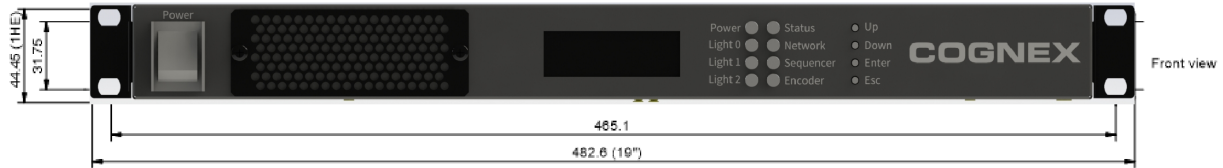

## Camera Adapter Plate

The camera adapter plate forms the mechanical connection piece between the camera and the camera mount. The standard camera adapter plate is suitable for mounting many cameras available on the market (mainly matrix cameras).

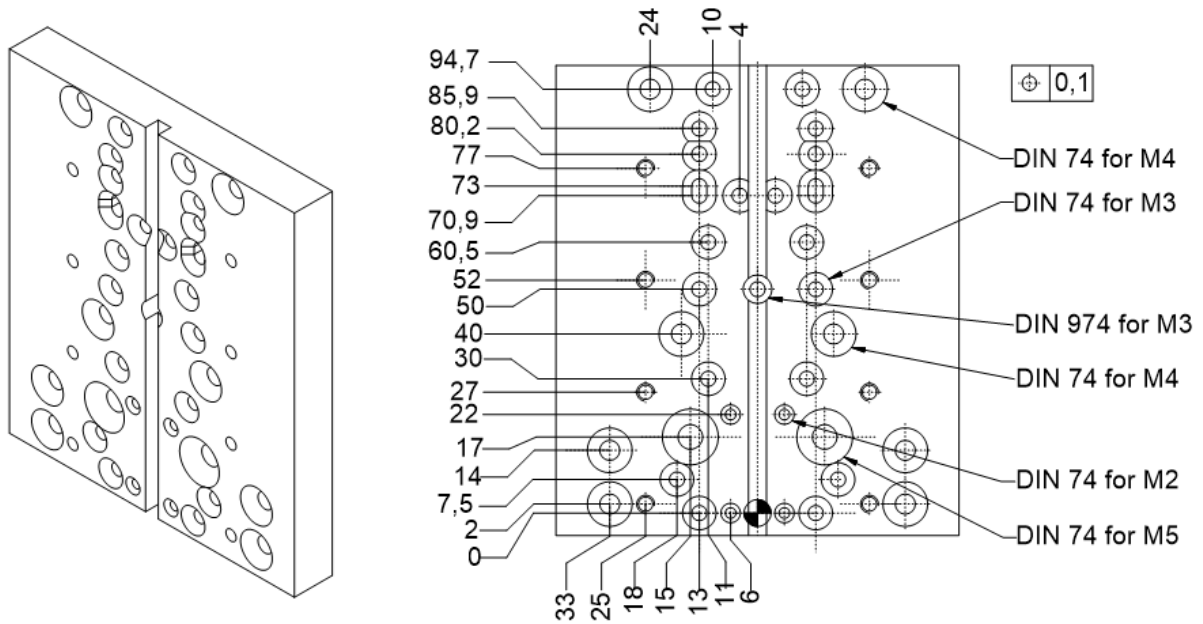

The adaptable camera types are the following:

Adaptable Camera Types	
Manufacturer	Camera Type/Series
Allied Vision	PIKE Guppy Guppy Pro STINGRAY Prosilica GT (1660, 1910, 1920, 2300, 2750) Prosilica GX (1050)
Basler	ACE ACA AVA (Aviator) PIA (Pilot)
Baumer	LXG (80, 120, 200) TXG (08, 12, 20, 50) SXG (40, 80) VLG (12, 20, 23, 24, 40)
Dalsa	Genie TS Genie Nano
Point Grey	Grasshopper Grasshopper2 Grasshopper3 Grasshopper Express Blackfly

**Note:** The list above serves only as an example. The adaptability depends on the optics you use.

## Camera Angle

The camera angle forms the mechanical connection piece between the camera and the camera mount. The camera angle is mainly used for mounting line scan cameras.

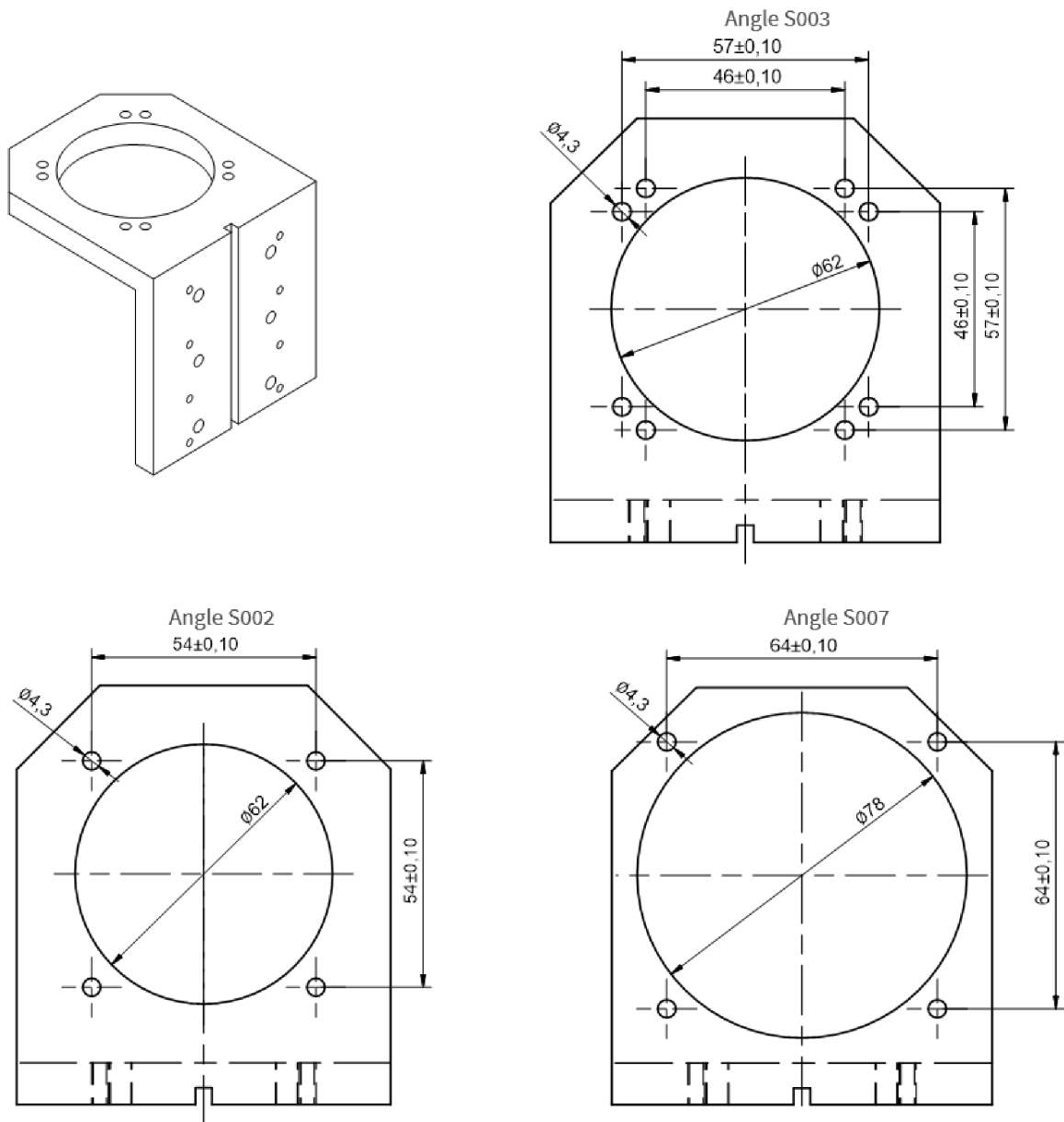

**Note:** The following list serves only as an example. The adaptability depends on the optics you use.

Adaptable Camera Types Angle S003	
Manufacturer	Camera Type/Series
Dalsa	Spyder 3

Adaptable Camera Types Angle S002	
Manufacturer	Camera Type/Series
Dalsa	Piranha 4 - 2k/4k (P4-CM-[02/04]K...)
Dalsa	Linea - 2k/4k (LA-[CM/CC/GM/GC]-[02/04]K...)

Adaptable Camera Types Angle S007	
Manufacturer	Camera Type/Series
Dalsa	Piranha 4 - 8k (P4-CM-08K...)
Dalsa	Linea - 8k/16k (LA-[CM/CC/GM/GC]-[08/16]K...)

## Timing Diagrams

The following sections list the timing diagrams of Trevista CI Dome.

### Trevista CI Dome

The timing diagram is the following:

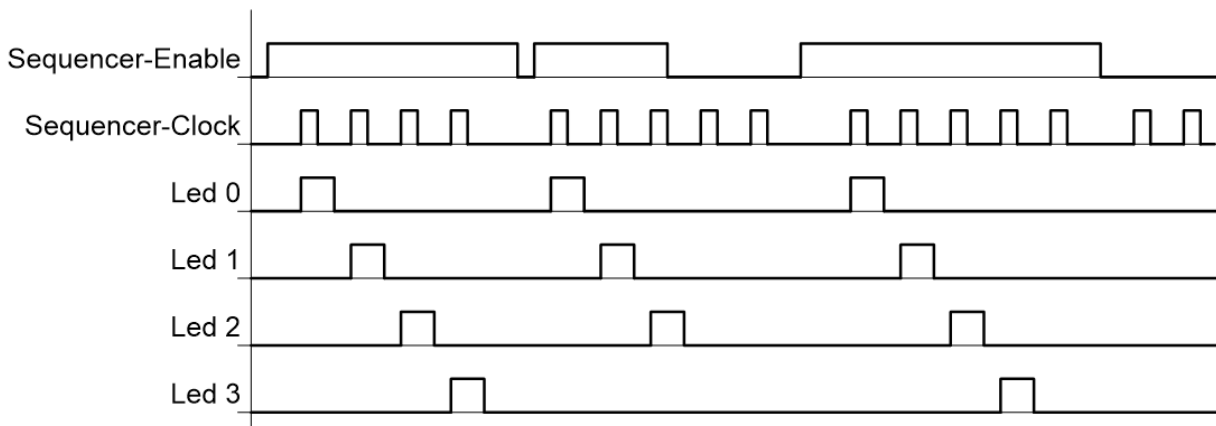

Signal Sources		
Signal	Default	Alternative
Sequencer enable	Software	Digital I/O, Input 0 Camera I/O 0, Input 1 Aux I/O, Input 1

Signal Sources		
Signal	Default	Alternative
Sequencer clock	Camera I/O 0, Input 0	Frequency generator Encoder Aux I/O, Input 0/2 Digital I/O, Input 6 Camera I/O 1, Input 0 Camera I/O 2, Input 0 Camera I/O 0, Input 1 Camera I/O 1, Input 1 Camera I/O 2, Input 1 High-Level

## Trevista CI Dome Scan

The timing diagram is the following:

Cycle repeat count = 2

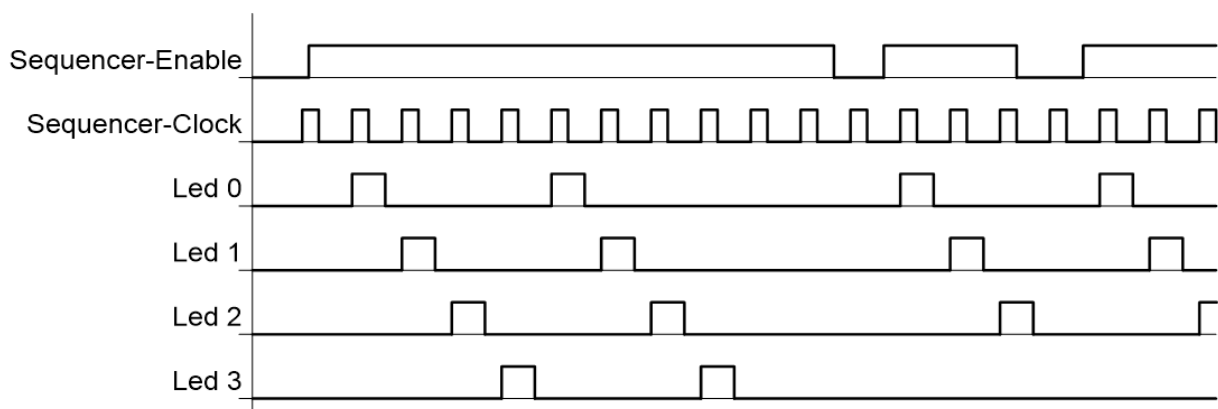

Signal Sources		
Signal	Default	Alternative
Sequencer enable	Software	Digital I/O, Input 0 Camera I/O 0, Input 1 Aux I/O Input 1
Sequencer clock	Encoder	Frequency generator Aux I/O Input 0/2 Digital I/O Input 6 Camera I/O 0, Input 0 Camera I/O 1, Input 0 Camera I/O 2, Input 0 Camera I/O 0, Input 1 Camera I/O 1, Input 1 Camera I/O 2, Input 1 High-Level

## Direction of Illumination Progression

The Trevista CI Dome has four separately accessible LED groups. By switching on these LED groups individually, you can generate different illumination processes. The following table shows the illumination processes for Trevista CI Dome:

Direction of the Illumination (from Bright to Dark)								
Number of Direction	0	1	2	3	4	5	6	7
Angle of Direction	0°	45°	90°	135°	180°	225°	270°	315°
Value for sequencer light sequence	0A	02	03	01	05	04	0C	08
Illumination process								

Trevista CI Dome image acquisition needs four different directions of the illumination processes. You can choose between axial and diagonal directions:

- Trevista CI Dome-diagonal uses the 1, 3, 5, and 7 directions.
- Trevista CI Dome-axial uses the 0, 2, 4, and 6 directions.

## Trevista CI Dome/Trevista CI Dome Scan

With Trevista CI Dome, the sequence ends after the third sequence step. With Trevista CI Dome Scan, the sequence is passed multiple times.

Trevista CI Dome/Trevista CI Dome Scan Diagonal				
Sequence Step	0	1	2	3
Number of Direction	3	1	5	7
Angle of Direction	135°	45°	225°	315°
Value for sequencer light sequence	01	02	04	08

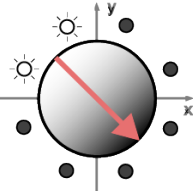
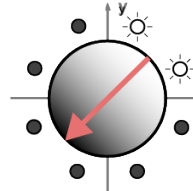
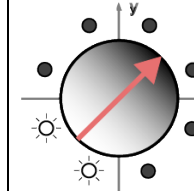
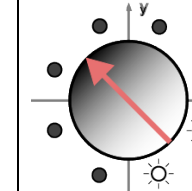
Trevista CI Dome/Trevista CI Dome Scan Diagonal				
Illumination process				
Name of the respective Trevista CI Dome input image in VisionPro	Shading 3	Shading 1	Shading 5	Shading 7

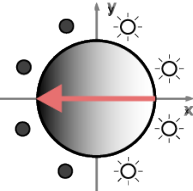
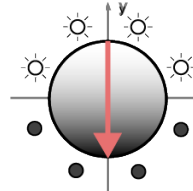
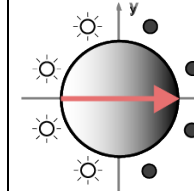
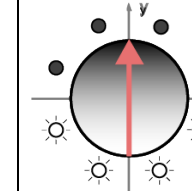
Trevista CI Dome/Trevista CI Dome Scan Axial				
Sequence Step	0	1	2	3
Number of Direction	3	2	4	6
Angle of Direction	0°	90°	180°	270°
Value for sequencer light sequence	0A	03	05	0C
Illumination process				
Name of the respective Trevista CI Dome input image in VisionPro	Shading 0	Shading 2	Shading 4	Shading 6

## Trevista CI Dome/Trevista CI Dome Scan Multiline

In Multiline mode, the sequence is passed multiple times.

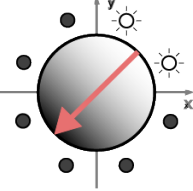
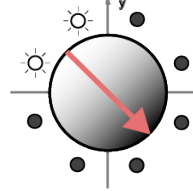
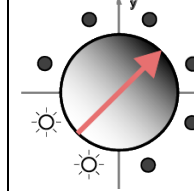
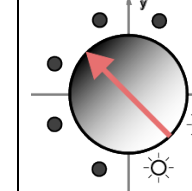
Trevista CI Dome/Trevista CI Dome Scan Multiline Diagonal				
Sequence Step	0	1	2	3
Number of Direction	1	3	5	7
Angle of Direction	45°	135°	225°	315°
Value for sequencer light sequence	02	01	04	08
Illumination process				
Name of the respective Trevista CI Dome input image in VisionPro	Shading 1	Shading 3	Shading 5	Shading 7

Trevista CI Dome/Trevista CI Dome Scan Multiline Axial				
Sequence Step	0	1	2	3
Number of Direction	0	2	4	6
Angle of Direction	0°	90°	180°	270°
Value for sequencer light sequence	0A	03	05	0C
Illumination process				
Name of the respective Trevista CI Dome input image in VisionPro	Shading 0	Shading 2	Shading 4	Shading 6

# Layouts

The following sections show the elements of the Trevista CI Dome and Dome Controller.

## Trevista CI Dome Layouts

Cognex supports three sizes of the Trevista CI Dome: S, M, and L.

### Trevista CI Dome S

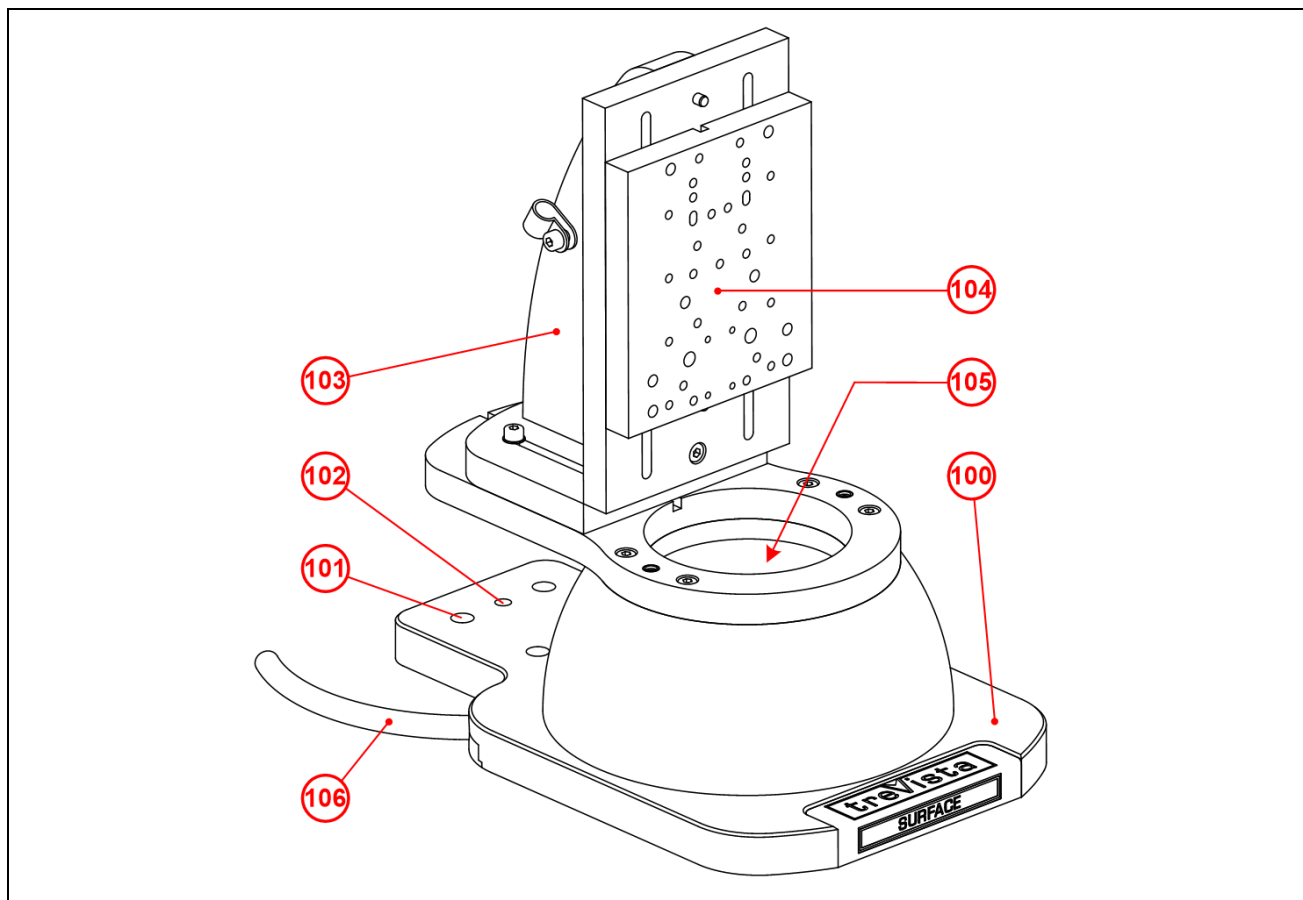

100	System carrier
101	Mounting holes
102	Fitting holes
103	Camera mount
104	Camera adapter plate
105	Dome aperture
106	Dome cable

## Trevista CI Dome M

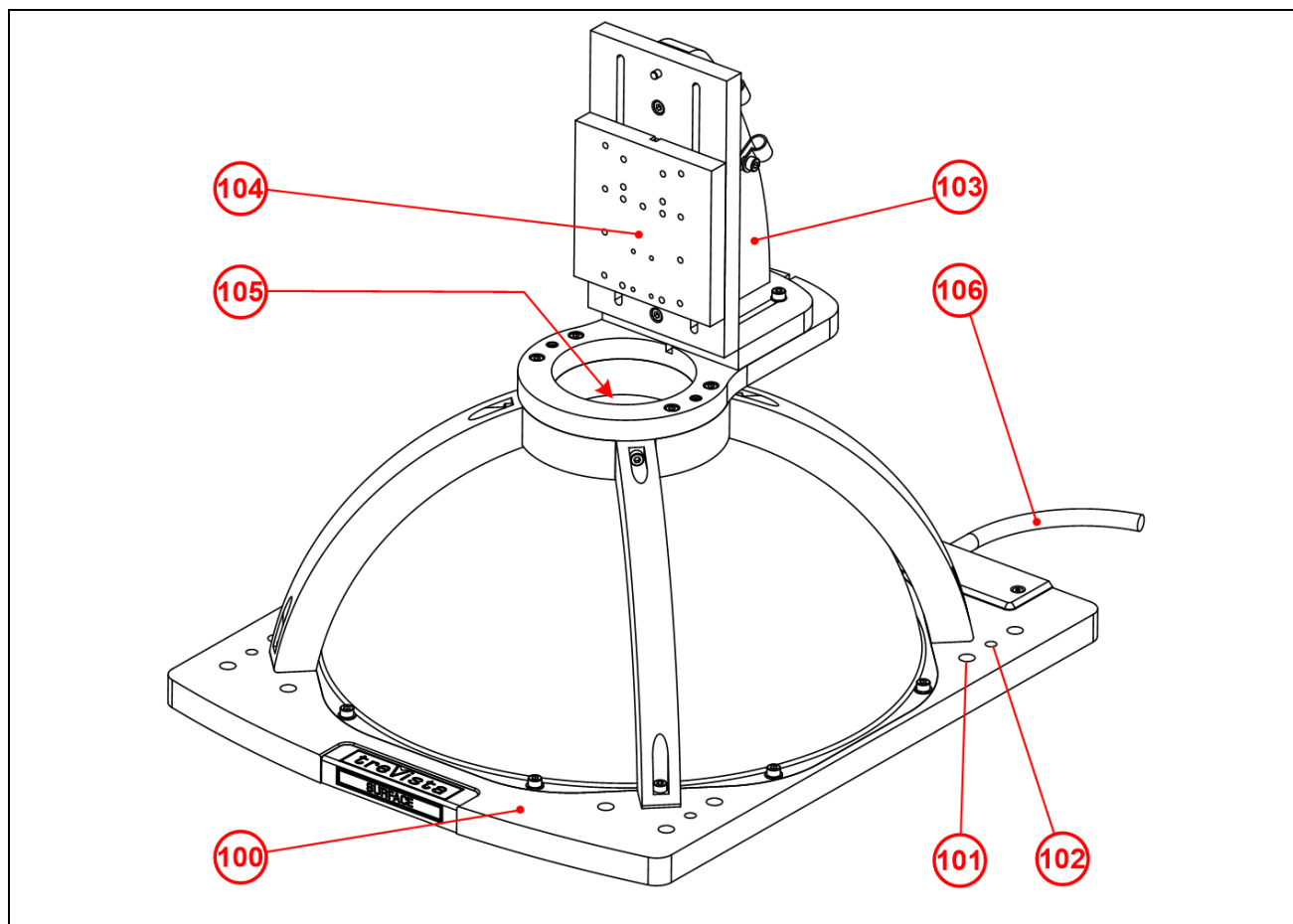

100	System carrier
101	Mounting holes
102	Fitting holes
103	Camera mount
104	Camera adapter plate
105	Dome aperture
106	Dome cable

## Trevista CI Dome L

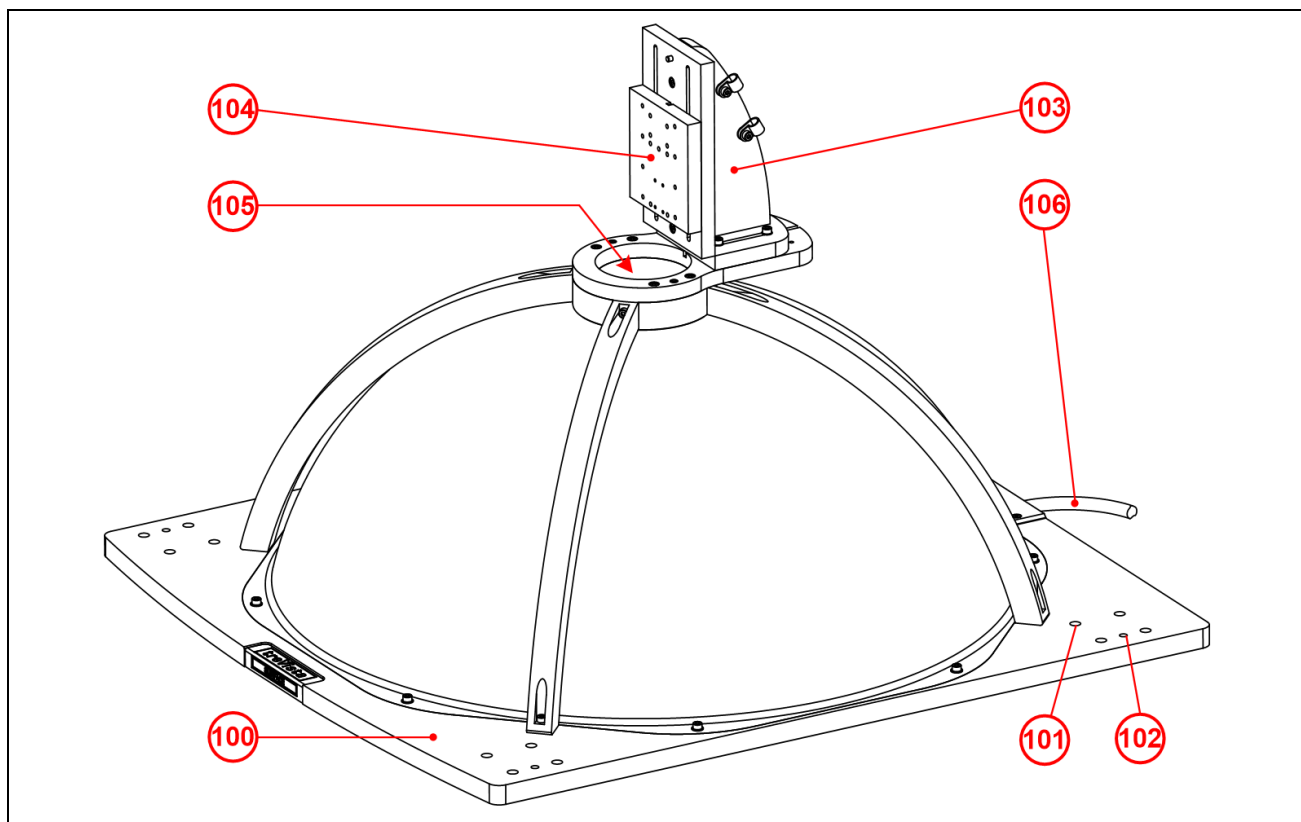

100	System carrier
101	Mounting holes
102	Fitting holes
103	Camera mount
104	Camera adapter plate
105	Dome aperture
106	Dome cable

## Controller Layouts

The Dome controller supports connections on the front and rear panels.

### Front Panel

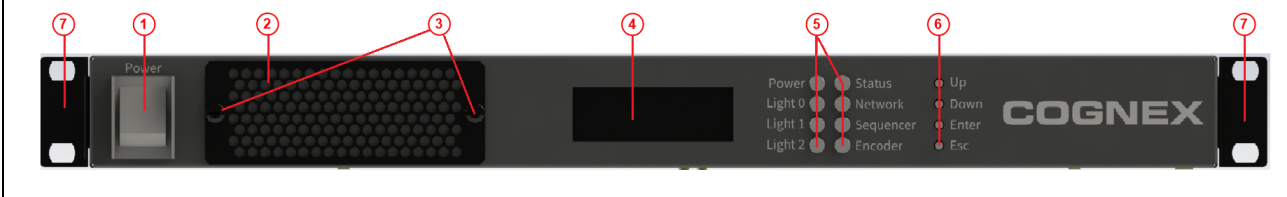

1	Power switch
2	Air inlet/filter
3	Phillips screws for replacing the air filter
4	Device display
5	LEDs
6	Menu buttons
7	Ears for securing the controller on the 19 inch rack

### Rear Panel

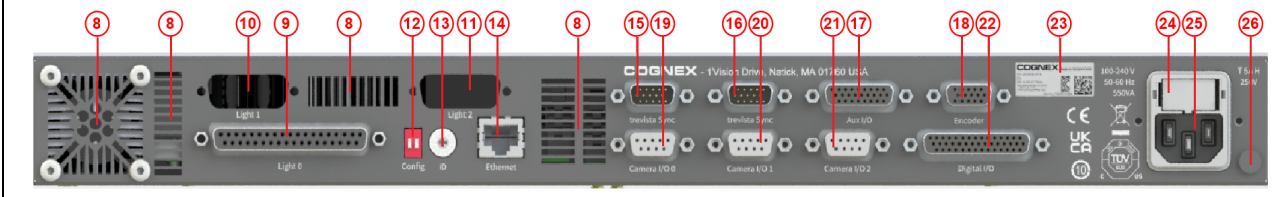

8	Air outlets
9	Light 0 connector
10	Light 1 connector
11	Light 2 connector
12	Config DIP switch
13	ID rotary coding switch
14	Ethernet connector
15	Trevista CI Dome Sync connector
16	Trevista CI Dome Sync connector
17	Aux I/O connector
18	Encoder connector
19	Camera I/O 0 connector
20	Camera I/O 1 connector
21	Camera I/O 2 connector
22	Digital I/O
23	Power input
24	Power input
25	Power input
26	Power input

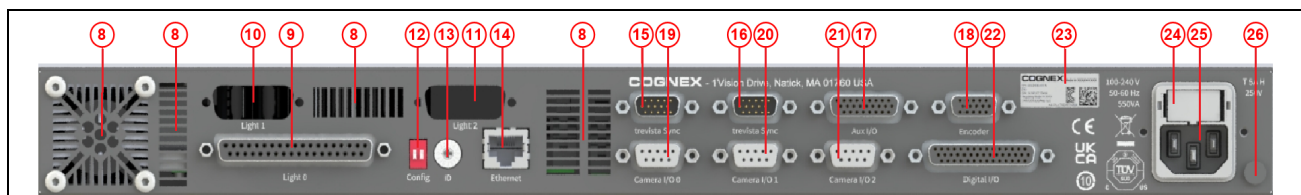

22	Digital I/O connector
23	Name plate/serial number
24	Fuses
25	IEC socket for main supply line
26	Ground connection

# Installation

## Mounting

The following section provides an overview about controller, dome, and camera mounting options.

### Mounting the Controller

The controller comes with a 19 inch housing, which you can mount on a 19 inch rack.

1. Secure the housing to the rack.
2. Screw the rails on the mounting ears of the controller.
3. Slide the controller into the housing.

---

**CAUTION:** Do not block the airflow of the device.

---

**CAUTION:** Room temperature cannot exceed 40 degrees. For more information, see [Operating Environment on page 14](#).

---

**CAUTION:** You can only mount the controller horizontally.

---

### Mounting the Dome

Mount the Dome using the M10 tapped holes.

A larger mounting surface leads to better heat dissipation. This prevents the dome from overheating.

Make sure that no dirt or dust gets into the inside of the dome during mounting or during operation. Under no circumstances may an electroconductive contamination occur (metal dust, metal shavings).

You can freely select the dome orientation of standard Dome systems and Dome systems with round dome aperture.

With Scan systems or with domes that have a slit aperture, the orientation of the dome depends on the direction of movement of the inspection object. Orient the slit aperture perpendicularly (90°) to the direction of movement.

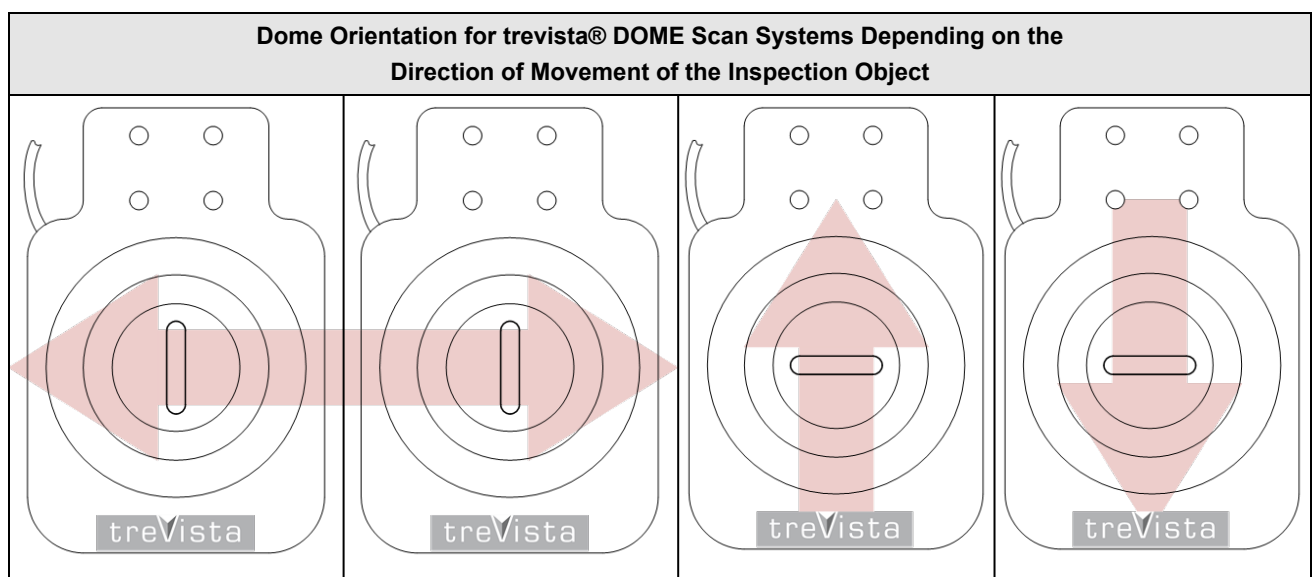

## Mounting the Camera

In most cases, you can mount the camera with the camera mount and the camera adapter plate. You can secure the camera mount to the dome in four orientations.

The camera mount is fastened to the dome with four screws. Two dowel pins ensure the exact adjustment of the dome and the camera mount.

**Note:** Since the dowel pins are hard to fit, we recommend stating the correct orientation of the camera mount already when the order is placed. Then the system will be delivered already correctly mounted.

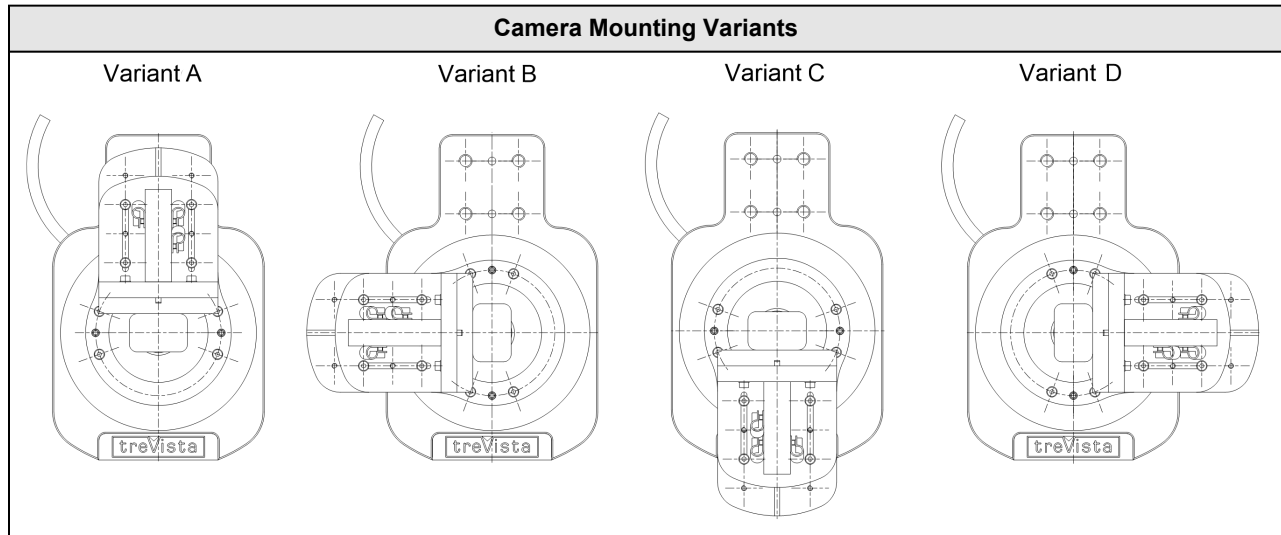

With some cameras, predominantly line-scan cameras, the adapter plate is replaced by a camera-specific adaption. Please contact us if you want to use a camera that cannot be mounted with the standard adapter plate.

## Camera Orientation

You can freely select the orientation of standard Dome systems.

With Scan systems, the camera orientation depends on the direction of movement of the inspection part. The sensor line is oriented perpendicularly ( $90^\circ$ ) to the direction of movement. The first pixel must be on the left in the direction of movement.

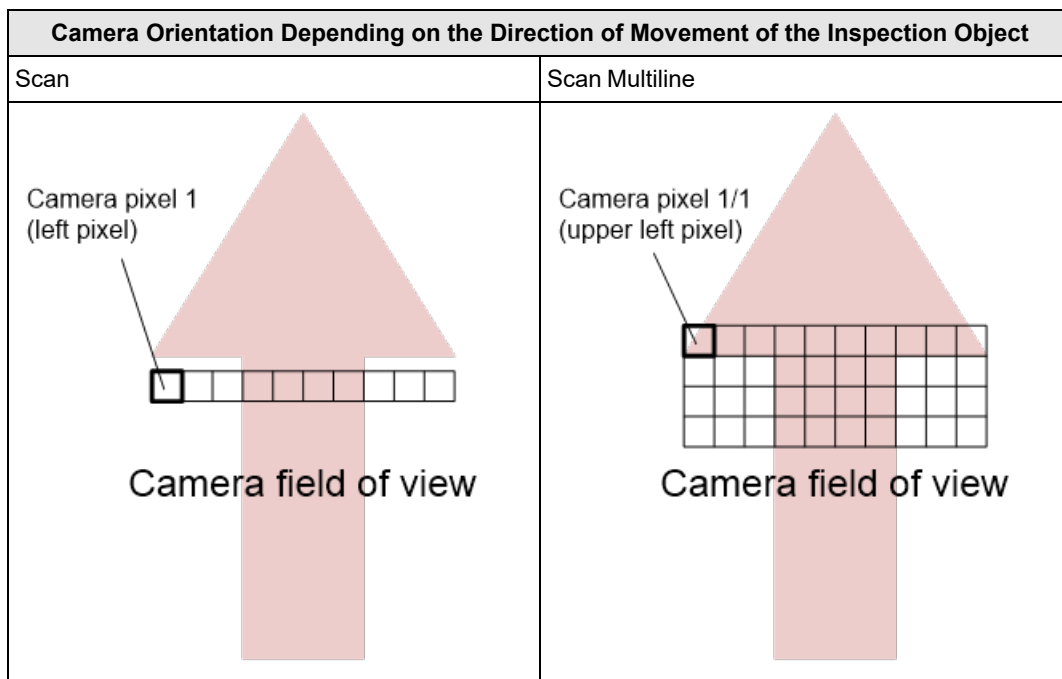

The orientation of the camera with reference to the dome system carrier depends on the orientation of both dome and camera. The controller must be informed about the orientation of the camera with reference to the dome system carrier when it is set up in order to ensure the correct lighting direction. This can be done with the sequencer parameter “Orientation”.

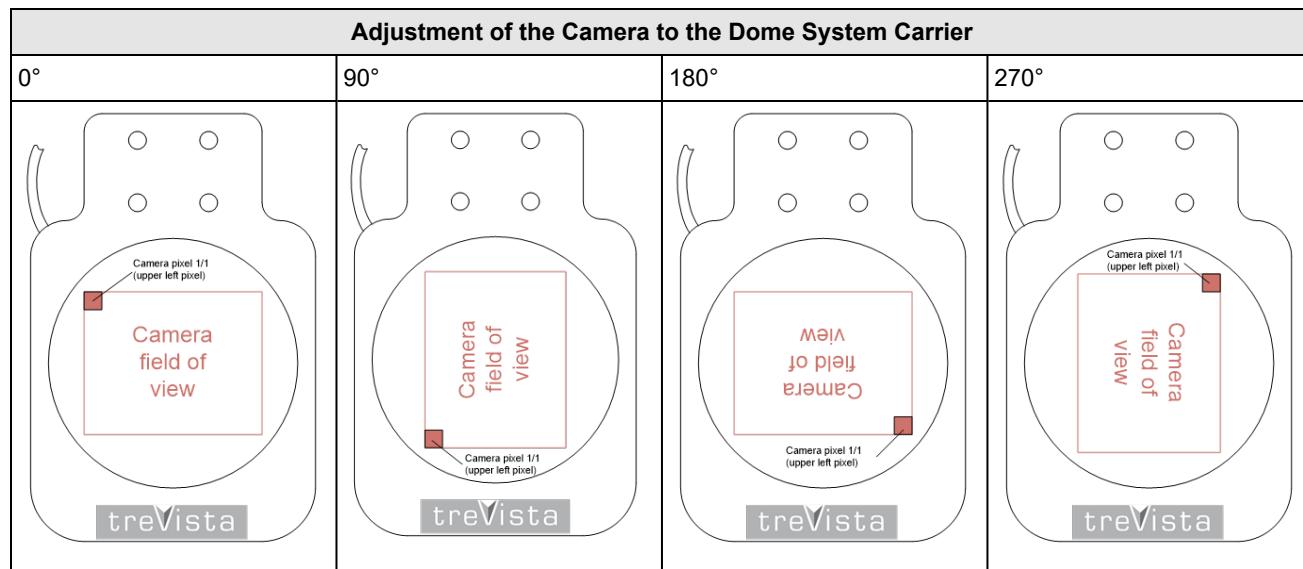

## Cabling

### Cabling Variants

**Note:** This chapter illustrates cabling variants schematically. The power connection is not shown.

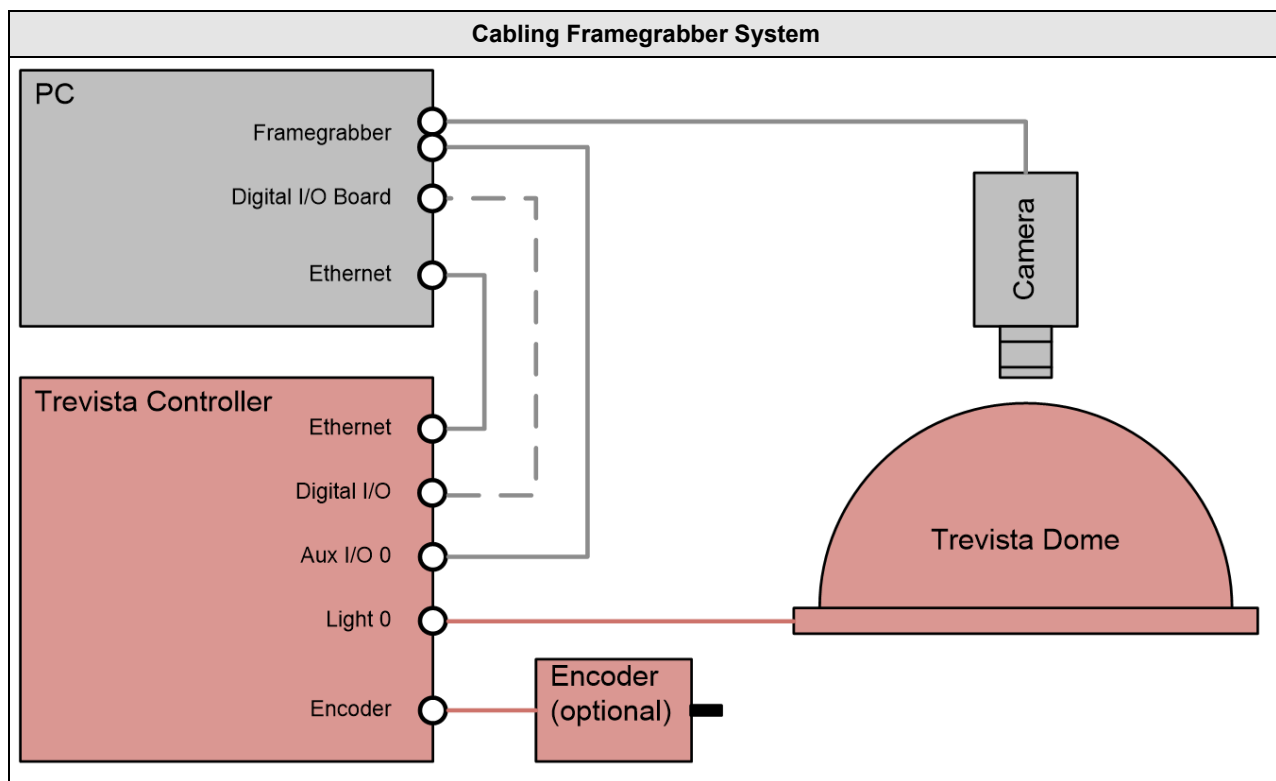
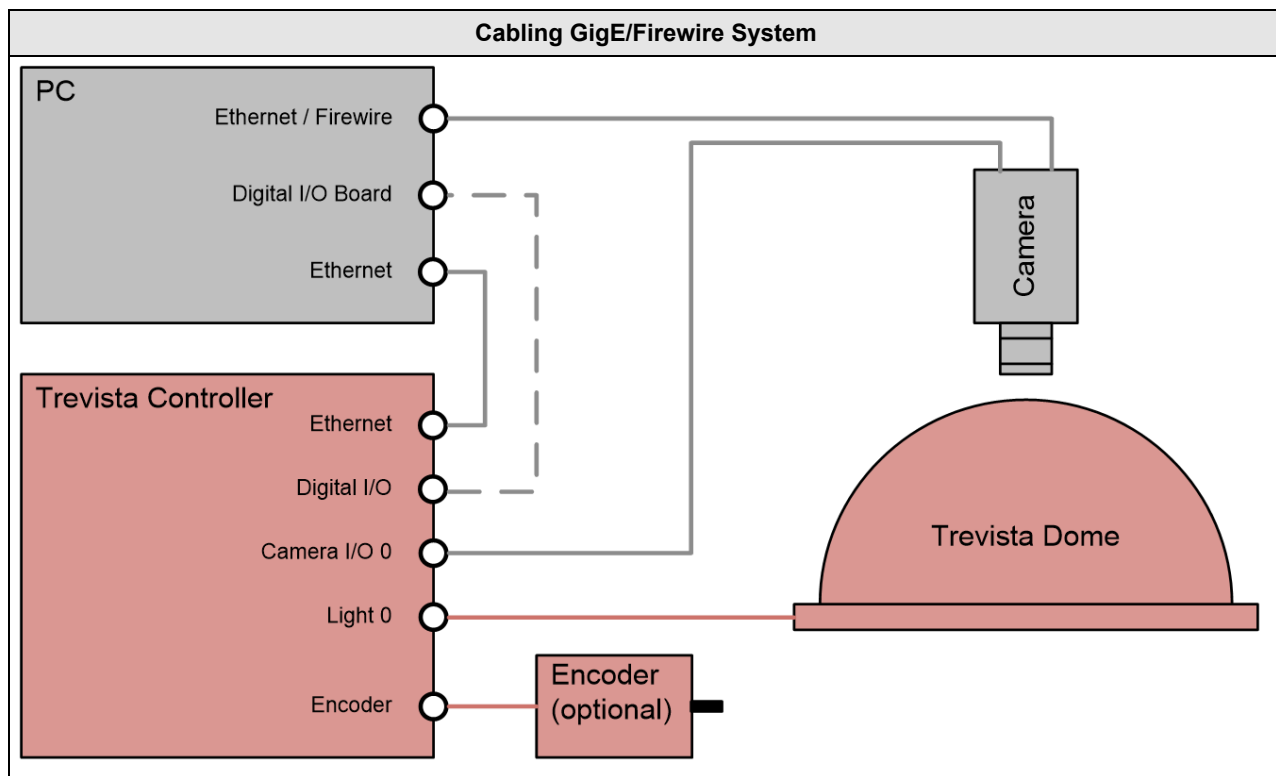

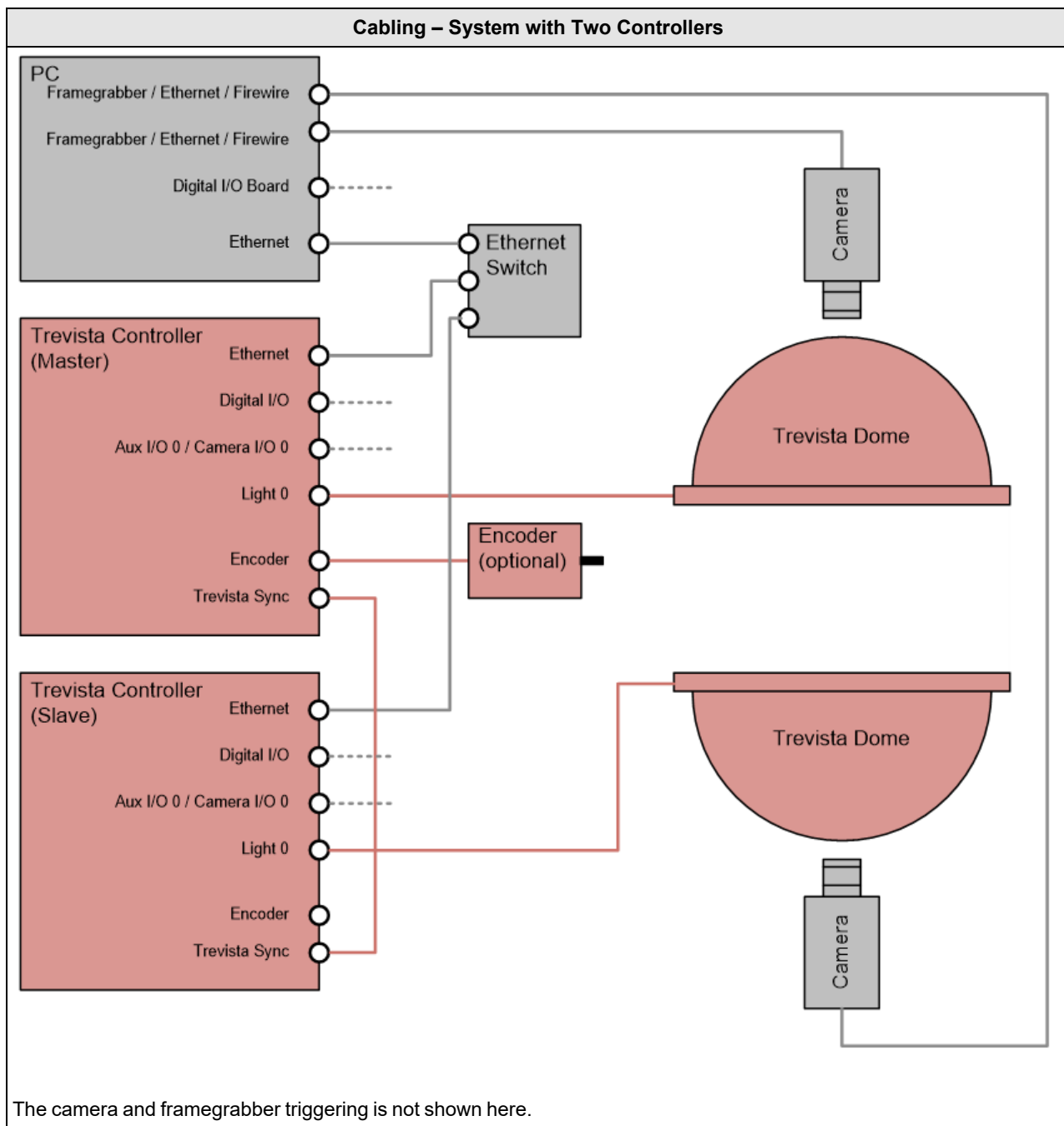

## Power Supply

Before connecting to the power supply, make sure that the controller is switched off.

**⚠ WARNING:** Use only the power supply cable provided by Cognex. Other power supply cables are not compatible.

**CAUTION:**

Before establishing the power supply connection, make sure that the supply network meets the following requirements:



- 100-240 V AC +/- 10%
- 50-60 Hz
- 550 VA

For more info, see [Operating Environment on page 14](#).

---

In order to connect to the power supply, connect the cold device plug of the power supply cable to the IEC socket (24) of the controller. Now connect the other plug of the power supply cable to your supply network.

# Device Mode and Functional Groups

The Trevista CI Dome controller arrives with one of the following factory-set device modes that cannot be changed:

- Area Scan
- Line Scan

The device mode determines the range of functions available to the controller. For example, a Trevista CI Dome setup using a controller in Area Scan mode does not support a rotary encoder.

Parameters not required for the current mode cannot be accessed and use default parameters set at the factory.

The following table provides an overview of the functionality any Trevista CI Dome controller supports depending on the configured device mode.

Functionality	Device Mode	
	Area Scan	Line Scan
Light 0 (Dome)	x	x
Light 1 + 2		
Camera I/O 0	x	x
Camera I/O 1+2		
Additional I/O (for camera/frame grabber)	x	x
Digital I/O	x	x
Sequencer basic functionality	x	x
Sequencer additional functionality		
Encoder		x

Activating optional functional groups enhances the standard range of functions of the two device modes. For example, by activating the functional group Sequencer additional functionality, you can access further sequencer features, such as setting a user-defined light sequence.

The following table provides an overview of optional functional groups.

Functionality	Functional Group	
	Light / camera I/O 1 + 2	Sequencer Additional Functionality
Light 1 + 2	x	
Camera I/O 1+2	x	
Sequencer additional functionality		x

## Device Mode

Trevista CI Dome has two device modes, Area Scan and Line Scan.

### Area Scan

Trevista CI Dome Area Scan mode produces slope, curvature, and texture images, of a stationary object.

The schematic layout of the Area Scan device mode:

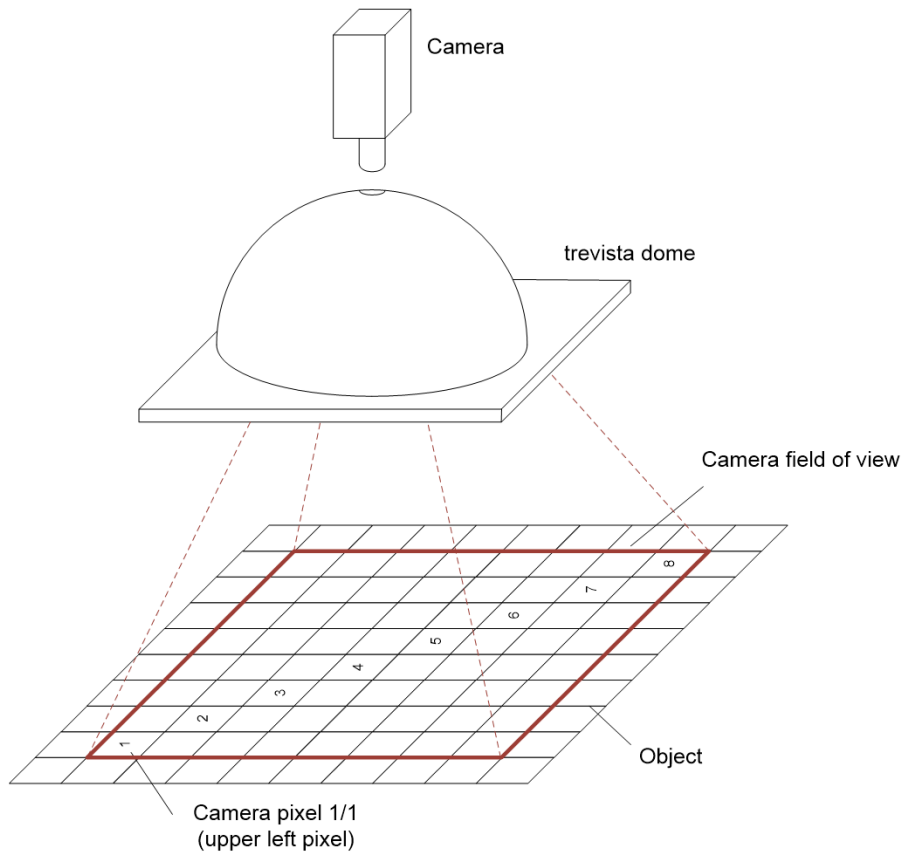

The camera captures four images and for each image, the object is illuminated from a different direction. Trevista CI Dome uses these input images to calculate the following output images:

- Slope in X direction
- Slope in Y direction
- Texture image
- Curvature image

Image acquisition and processing in Area Scan mode:

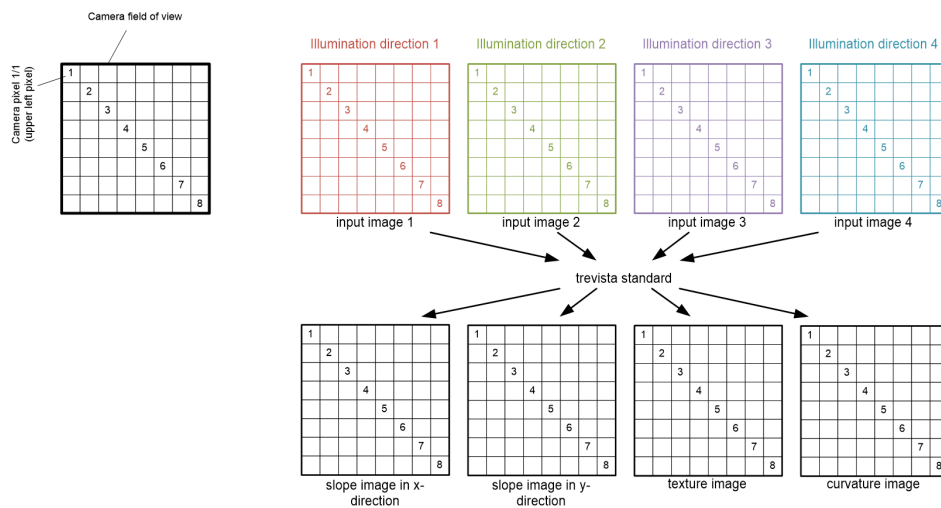

## Line Scan

Trevista CI Dome Line Scan mode produces slope, curvature, and texture images, of a rotating or moving object.

The schematic layout of the Line Scan device mode:

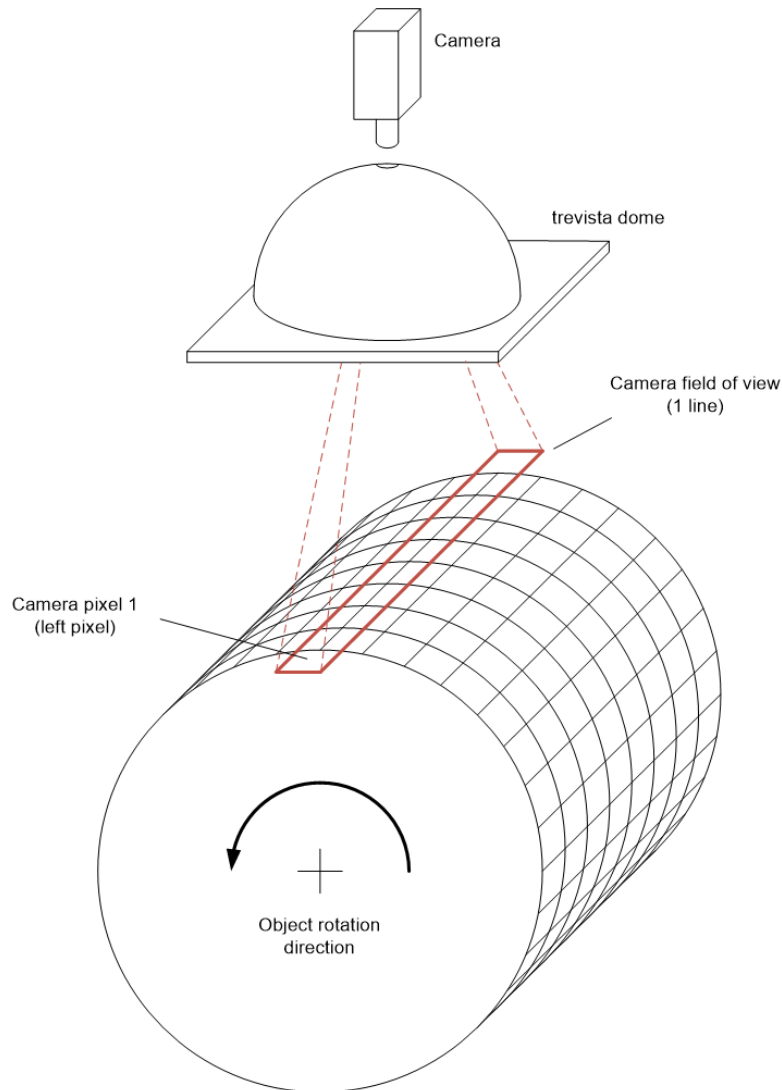

A line-scan camera captures images where the width corresponds to the desired width of the measuring field. The object feed rate between two image acquisitions must be exactly one fourth of one line height. Lines are then captured continuously. Four subsequent lines are always lighted from different directions.

The Line Scan algorithm calculates the four input images from the single images taken. The algorithm uses the input images to calculate the output images of slope, curvature, and texture.

Image acquisition and processing in Line Scan mode:

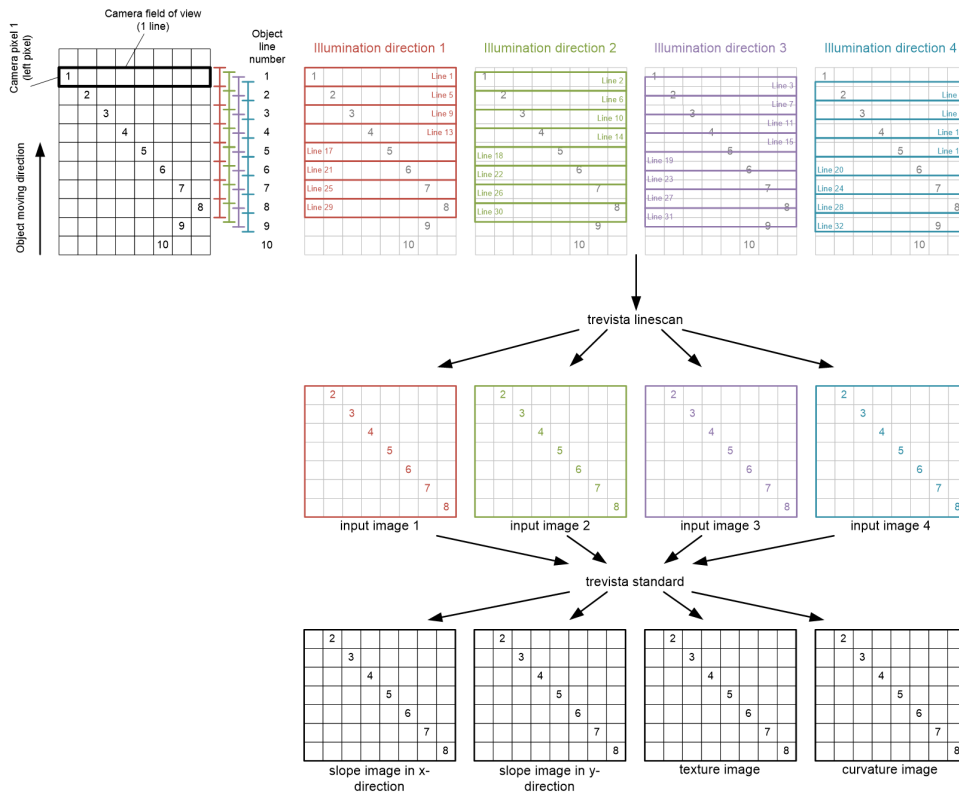

## Functional Groups

You can extend the default range of functions of the device modes Area Scan and Line Scan by activating optional functional groups. You must specify the desired additional functionality before placing an order for the controller.

## Light/Camera I/O 1 + 2

The functional group Light/Camera I/O 1 + 2 lets you use and parameterize the Light 1 + 2 and Camera I/O 1 + 2 interfaces.

Connect further single-channel lighting through the Light 1 + 2 interface.

**WARNING:** The output drivers of the Light 1 + 2 interfaces are pure sources of electricity. Operating light that requires constant voltage or light with an electrical ballast can lead to the destruction of the controller or the light.

**!** Connecting lighting with a capacitive or an inductive impedance can lead to the destruction of the controller or the lighting.

The forward voltage of the light cannot exceed 35 V with the desired operating current, measured at the controller connector. The controller may limit the operating current so the maximum permissible power dissipation is not exceeded at the controller end. The higher the forward voltage of the light, the higher the maximum possible operating current.

The interfaces Camera IO 1 + 2 and Camera IO 0 are identical in design and can support up to two additional cameras that work together with lights 1 and 2.

## Sequencer

The functional group Sequencer Additional Functionality allows you to alter the lighting sequence extensively. Depending on the device mode, you can alter the following parameters:

- Sequence length
- Switch-on time of the individual channels of light 0, 1, and 2
- Trigger time of cameras 0, 1, and 2
- Number of sequence repeats
- Number of step repeats

# Controller Interfaces

The following sections describe the interfaces between the Dome controller and connected devices of a Trevista CI Dome.

**Note:**

- Only use shielded cables for the external cabling of the Dome controller. The cable shielding must be applied on both sides.
- Cables connected to the Dome controller must not exceed a length of 10 m (32.81 ft).
- You can only connect and disconnect Dome controller connectors when the Dome controller is switched off. Connecting or disconnecting connectors during operation may lead to the destruction of the components.
- You must connect the ground connection (26) of the Dome controller to the surrounding machine or control cabinet ground. The ground cable must not exceed a length of 1 m (3.28 ft) and must have a wire cross section of at least 2.5 mm<sup>2</sup> (0.039 in<sup>2</sup>). Cognex recommends to use an HF band with copper braiding to enhance interference immunity.

## Ethernet

You control and parametrize the Dome controller through the Ethernet interface. Alternatively, you can save the parametrization in the device. In this case, using the Ethernet interface is optional when you control the illumination unit through the sequencer release digital I/O line.

## Camera I/O

You can supply the camera with 12 V or 24 V voltage through the Camera I/O interface. Additionally, you can connect up to two signals from the camera to the Dome controller through inputs 0 and 1, for example “Integration Enable” or “Exposure”. The two inputs are galvanically isolated. You can use outputs 0 and 1 as TTL or open-drain outputs.

## Basic Circuit

The following image shows the basic internal circuit of the Camera I/O interface:

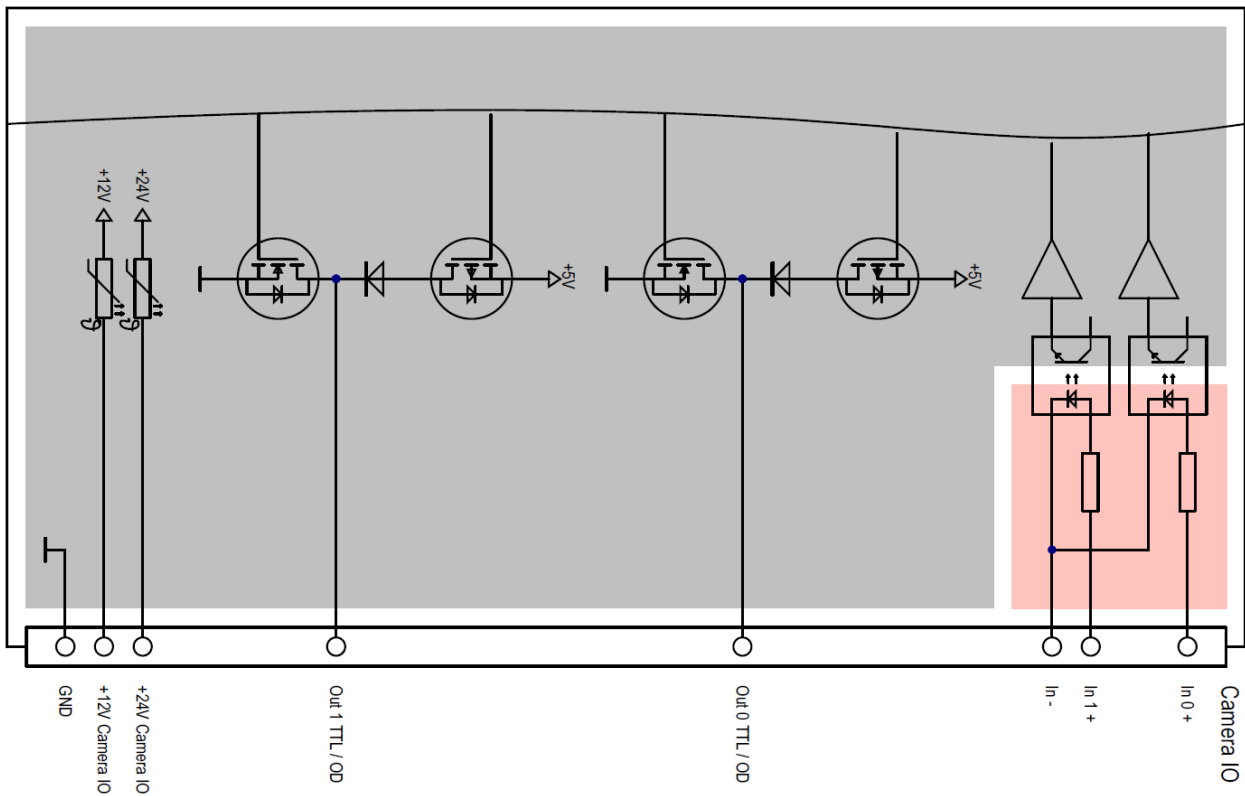

## Pin Assignment

The following image shows the pin assignment of the Camera I/O interface:

D-Sub 9-Pin Female Connector (viewed from the front)

Pin Number	Name	Description	Type	Level
1	Out 0 TTL/OD	Output 0 can be used in push/pull version with TTL level or as an open drain.	O	TTL: 5 V OD: max. 24 V
6	Out 1 TTL/OD	Output 1 can be used in push/pull version with TTL level or as an open drain.	O	TTL: 5 V OD: max. 24 V
4	In 0 +	Input 0.	I	5-24 V
3	In 1+	Input 1.	I	5-24 V
8	In -	Reference potential for the inputs	I	
2 7	GND	Mass/reference potential for the power supply outputs and the digital outputs.	O	



D-Sub 9-Pin Female Connector (viewed from the front)

Pin Number	Name	Description	Type	Level
5	+24 V Camera IO	24 V output for the camera supply (max. 1 A).	O	24 V
9	+12 V Camera I/O	12 V output for the camera supply (max. 2 A).	O	12 V

<sup>1</sup> With hardware versions 0 and 1, pin 1 is only a TTL output. A connection as an open-drain output is not possible.

<sup>2</sup> In hardware versions 0 and 1, pin 6 is supplied with the signal Out 0 and is only designed as an open-drain output. A connection as a TTL output is not possible.

## Connection Example

### Sequencer Control

The following illustration shows the signal path from the camera to the Dome controller. This enables you, for example, to control the sequencer clock or the sequencer enabling.

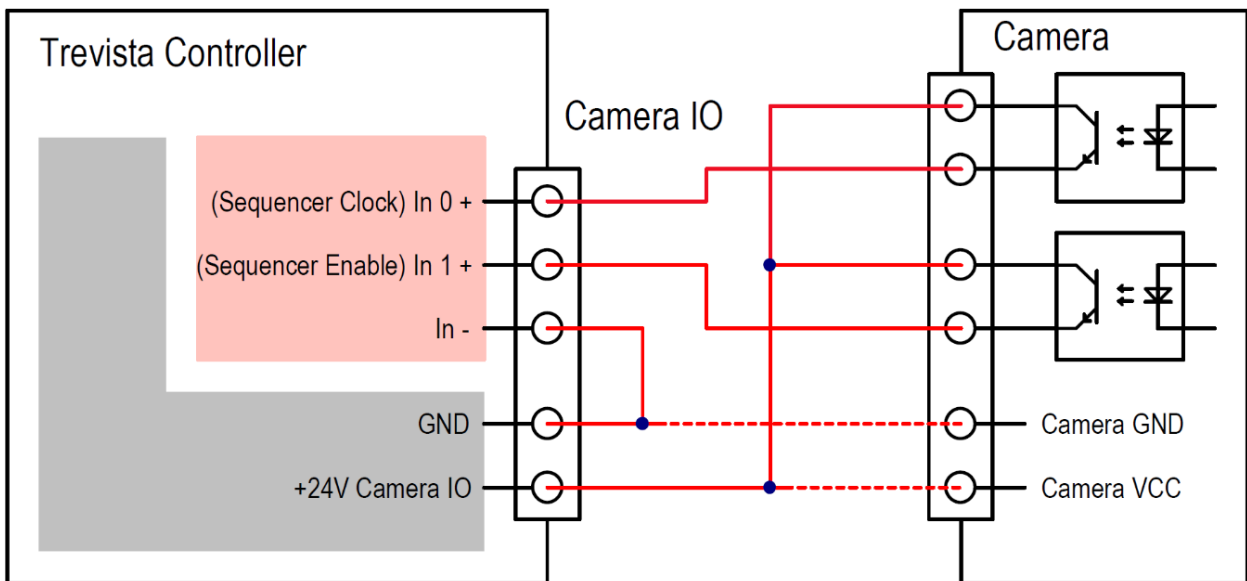

Input 0 is the sequencer clock, usually used with matrix cameras in standard device mode. You can select the logic signal assigned to the camera output for most cameras. For this example, the output signals that the camera is exposing (Integration-Enable, Exposure, ...).

By wiring Input 1 (sequencer release), you can control the sequencer if you do not want to control it through the software.

### Camera Trigger

The following two illustrations show the signal path from the Dome controller to the camera. This wiring is only required in special cases as it enables, for example, the Dome controller to trigger the camera. You can use outputs 0 and 1 as TTL or open-drain outputs.

The following image shows output 0 or 1 used as a TTL output.

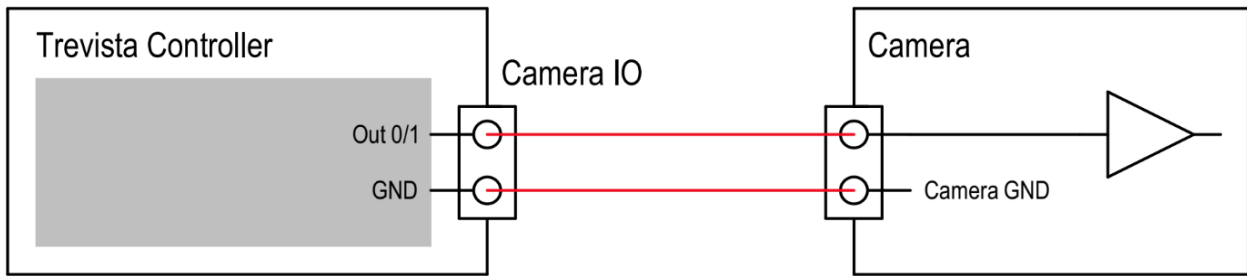

The following image shows output 0 or 1 used as an open-drain output.

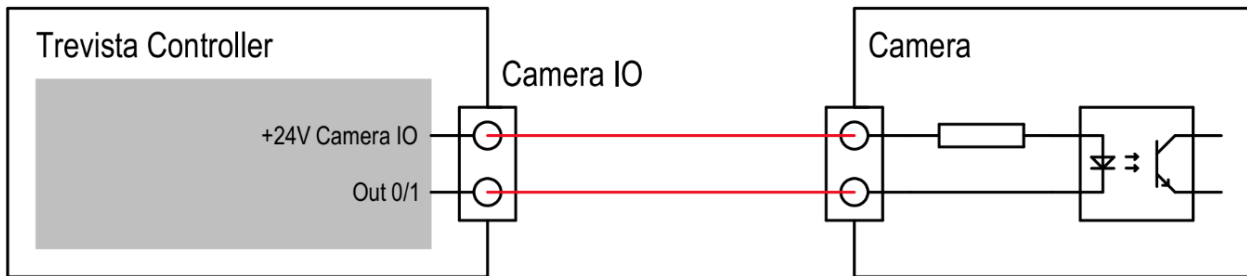

## Electrical Data

TTL/open-drain outputs (Out 0/1 TTL/OD)

Parameter	Test Condition	Minimum	Typical	Maximum	Unit
Output impedance			10		$\Omega$
Output current				30	mA
High-level output voltage (TTL)	$I_{Out} = 100 \mu A$	4.9		5.5	V
	$I_{Out} = 30 \text{ mA}$	4.2		5.1	
Low-level output voltage	$I_{Out} = 100 \mu A$			0.2	V
	$I_{Out} = 30 \text{ mA}$			0.5	
Permitted voltage range (OD)		-0.3		25	V

Input (In 0/1)

Parameter	Test Condition	Minimum	Typical	Maximum	Unit
Input voltage for low level		-0.5		1	V
Input voltage for high level		4.5		25	V
Input current	$U_{Input} = 0 \text{ V}$		0		mA
	$U_{Input} = 5 \text{ V}$		5		
	$U_{Input} = 12 \text{ V}$		5		
	$U_{Input} = 24 \text{ V}$		6		

+12 V supply output (+12 V Camera I/O)

Parameter	Test Condition	Minimum	Typical	Maximum	Unit
Output voltage	$I_{Out} = 0 \text{ A}$	11.5	12	12.5	V
	$I_{Out} = 2 \text{ A}$	11.2		12.3	

Output current				2	A
----------------	--	--	--	---	---

+24 V supply output (+24 V Camera I/O)

Parameter	Test Condition	Minimum	Typical	Maximum	Unit
Output voltage	$I_{Out} = 0 \text{ A}$	23.2	24	24.8	V
	$I_{Out} = 1 \text{ A}$	23		24.6	
Output current				1	A

## Aux I/O

The Aux I/O interface is a universal interface that you can use, for example, to trigger a frame grabber.

The two outputs are available as TTL, LDVS, and RS-422 variants. The voltage at the pin “Out TTL VCC” determines the output voltage of the TTL outputs. Connect the pin “Out TTL VCC” to either the pin “+5 V Aux IO” or to the pin “+3.3 V Aux IO” to set the high level at the TTL outputs at 3.3 V or 5 V, respectively. You must only use the pins “+5 V Aux IO” and “+3.3 V Aux IO” for this purpose.

The interface has two inputs. Two inputs are designed as a TTL variant, and two as an LVDS variant.

**Note:** Never interconnect the pins “+5 V Aux IO” and “+3.3 V Aux IO”. Please use the pins “+5 V Aux IO” and “+3.3 V Aux IO” exclusively for supplying the TTL output drivers.

## Basic Circuit

The following image shows the basic internal circuit of the Aux I/O interface:

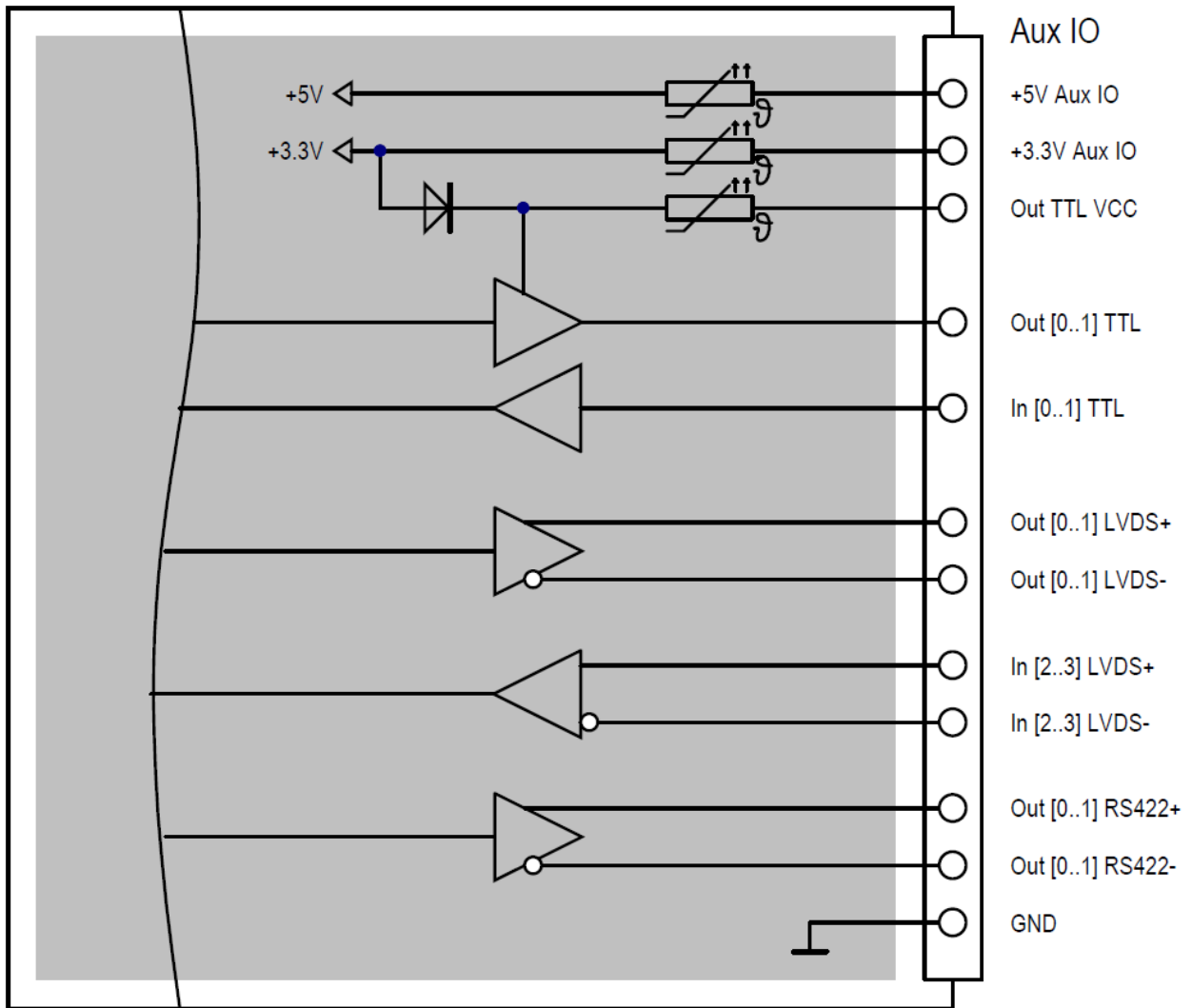

## Pin Assignment

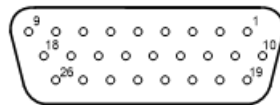

D-Sub HD 26-Pin Female Connector (viewed from the front)

Pin Number	Name	Description	Type	Level
20	Out 0 TTL	Output 0, TTL	O	Out TTL VCC
2	Out 1 TTL	Output 1, TTL	O	Out TTL VCC
11	Out TTL VCC	Supply voltage for the TTL outputs. You can determine the level of the TTL outputs with this input.	I	3.3-5 V

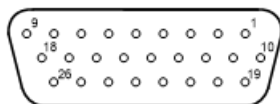

D-Sub HD 26-Pin Female Connector (viewed from the front)

Pin Number	Name	Description	Type	Level
19	+3.3 V Aux IO	3.3 V output for supplying the TTL outputs.	O	3.3 V
1	+5 V Aux IO	5 V output for supplying the TTL outputs.	O	5 V
12	In 0 TTL	Input 0, TTL	I	3.3-5 V
21	In 1 TTL	Input 1, TTL	I	3.3-5 V
17	In 2 LVDS+	Input 2, LVDS+	I	LVDS
7	In 2 LVDS-	Input 2, LVDS-	I	LVDS
18	In 3 LVDS+	Input 3, LVDS+	I	LVDS
8	In 3 LVDS-	Input 3, LVDS-	I	LVDS
15	Out 0 LVDS+	Output 0, LVDS+	O	LVDS
5	Out 0 LVDS-	Output 0, LVDS-	O	LVDS
16	Out of 1 LVDS+	Output 1, LVDS+	O	LVDS
6	Out of 1 LVDS-	Output 1, LVDS-	O	LVDS
13	Out 0 RS-422+	Output 0, RS-422+	O	RS-422
22	Out 0 RS-422-	Output 0, RS-422-	O	RS-422
4	Out 1 RS-422+	Output 1, RS-422+	O	RS-422
14	Out 1 RS-422-	Output 1, RS-422-	O	RS-422

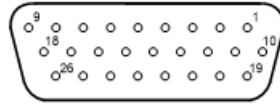

D-Sub HD 26-Pin Female Connector (viewed from the front)

Pin Number	Name	Description	Type	Level
3 9 10 23 24 25 26	GND	Mass/reference potential for all signals.	P	

**Note:**

ⓘ All signals have a reference to the signal ground (GND). You must connect signal ground (GND) between the devices regardless of the input or output type you use (TTL, LVDS, RS-422).

### Connection Example

The following image shows an example of connecting the 5 V TTL outputs of the Dome controller:

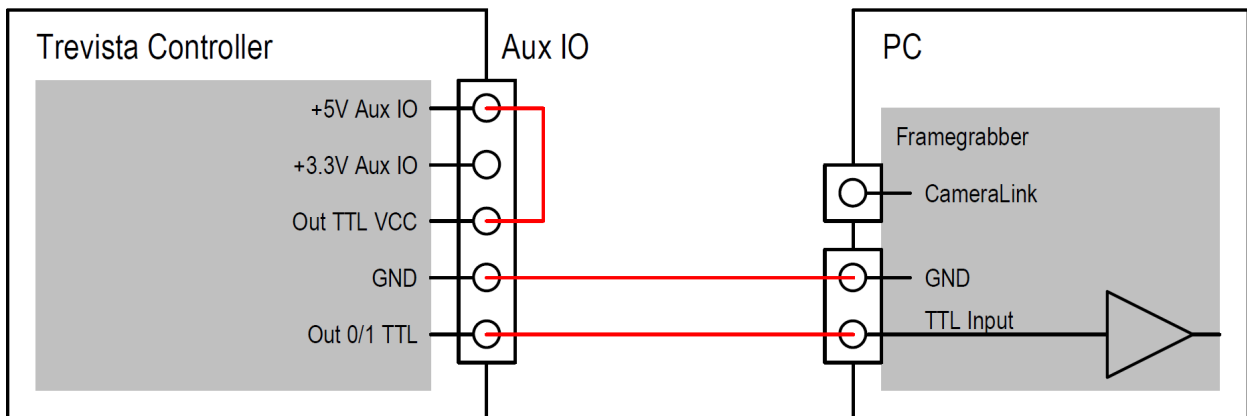

The following image shows an example of connecting the LVDS outputs of the Dome controller:

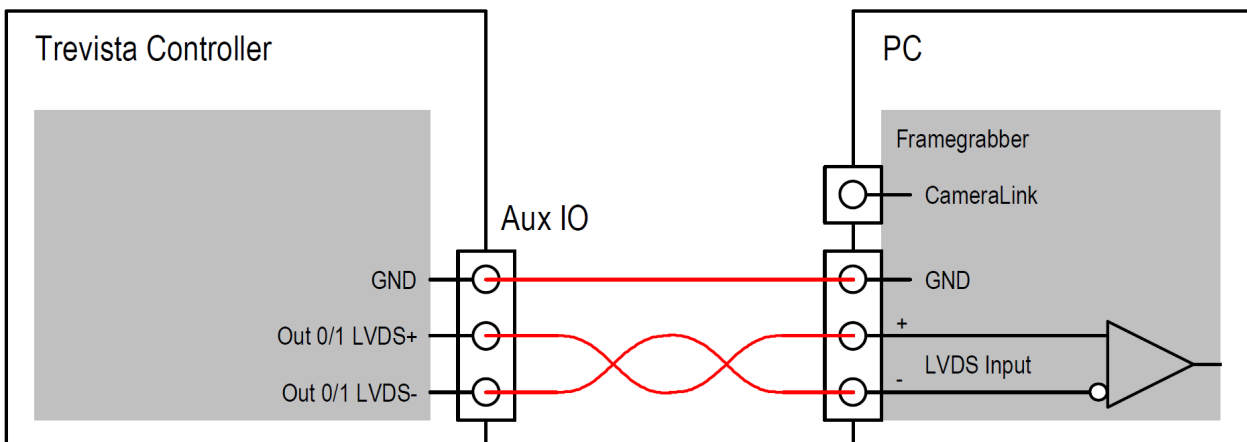

The following image shows an example of connecting the TTL inputs of the Dome controller:

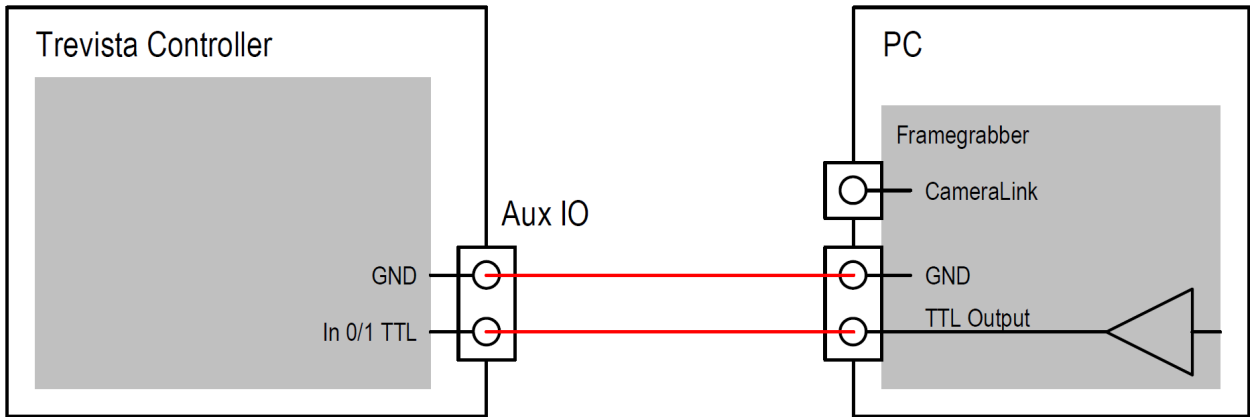

The following image shows an example of connecting the LVDS inputs of the Dome controller:

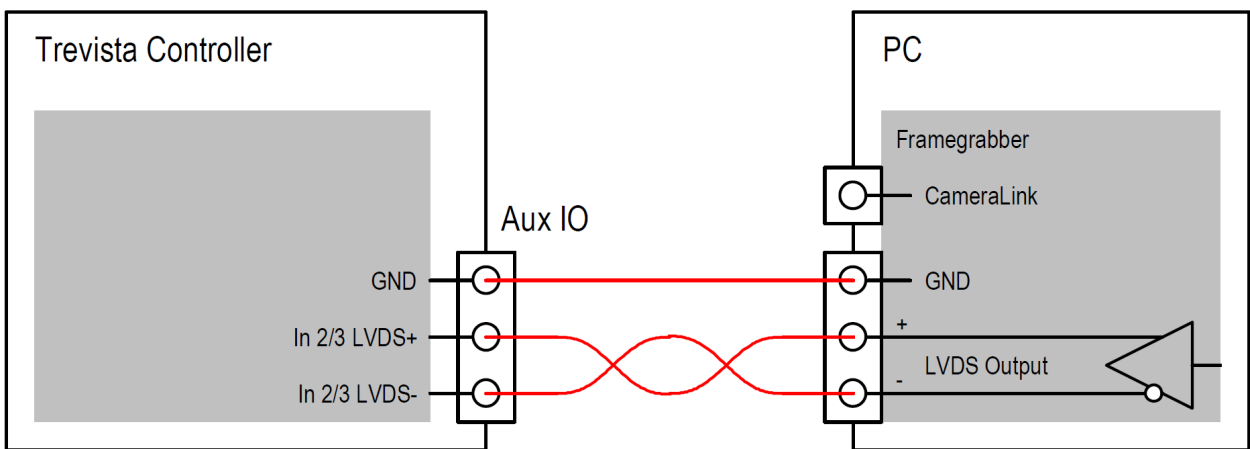

## Electrical Data

TTL output (Out 0/1 TTL)

Parameter	Test Condition	Minimum	Typical	Maximum	Unit
Output impedance			10		$\Omega$
Input voltage at Out TTL VCC				5.1	V
High-level output voltage	Out TTL VCC unconnected				V
	$I_{Out} = 100 \mu A$	2.9		3.0	
	$I_{Out} = 16 \text{ mA}$	2.7		2.8	
	Out TTL VCC = 3.3 V				
	$I_{Out} = 100 \mu A$	3.1		3.3	
	$I_{Out} = 16 \text{ mA}$	2.9		3.15	
	Out TTL VCC = 5 V				
	$I_{Out} = 16 \text{ mA}$	4.6		4.85	
Low-level output voltage	$I_{Out} = 100 \mu A$		0.2		V
	$I_{Out} = 16 \text{ mA}$	0.3	0.6		

## TTL input (In 0/1 TTL)

Parameter	Test Condition	Minimum	Typical	Maximum	Unit
Input impedance	$U_{IN} = 3.3 \text{ V}$		4.7		k $\Omega$
Input voltage for low level				0.6	V
Input voltage for high level		2.5			V
Input current	$U_{IN} = 3.3 \text{ V}$			1	mA
	$U_{IN} = 5 \text{ V}$			3	

## LVDS output (Out 0/1 LVDS)

Parameter	Test Condition	Minimum	Typical	Maximum	Unit
Differential output voltage	$R_L = 100 \Omega$	$\pm 247$	$\pm 340$	$\pm 454$	mV
Common mode output voltage		1.125	1.2	1.375	V

## LVDS input (In 2/3 LVDS)

Parameter	Test Condition	Minimum	Typical	Maximum	Unit
Differential input impedance			100		$\Omega$
Differential input voltage		$\pm 100$		$\pm 600$	mV
Common mode input voltage		0.3		2.4	V

## RS-422 output (Out 0/1 RS-422)

Parameter	Test Condition	Minimum	Typical	Maximum	Unit
Differential output voltage	$R_L = 100 \Omega$	$\pm 2.0$	$\pm 3.25$		V
Common mode output voltage	$R_L = 100 \Omega$		1.6		V

## 3.3 V voltage output (+3.3 V Aux IO)

Parameter	Test Condition	Minimum	Typical	Maximum	Unit
Output voltage	$I_{Out} = 100 \mu\text{A}$	3.2	3.3	3.4	V
	$I_{Out} = 10 \text{ mA}$	3.1		3.3	
Output current				30	mA

## 5 V voltage output (+5 V Aux IO)

Parameter	Test Condition	Minimum	Typical	Maximum	Unit
Output voltage	$I_{Out} = 100 \mu\text{A}$	4.9	5	5.2	V
	$I_{Out} = 10 \text{ mA}$	4.8		5.1	
Output current				30	mA

## Digital I/O

The Digital I/O interface provides eight digital inputs and eight digital outputs as 24 V variants. The inputs and outputs are galvanically isolated.

**Note:** When the output drivers are supplied with an internal voltage, the galvanic isolation of the outputs is lost.

Optionally, you can apply an external sequencer enable signal to Input 0 if you cannot or do not want to enable the sequencer from software.

You must supply 12-24 V external voltage at the pin “Out VCC” to the digital output drivers. Alternatively, you can use the controller-internal voltages at the pins “+12 V Digital IO” or “+24 V Digital IO”. In this case, you must also interconnect the pins “GND” and “Out GND”.

**Note:** Each output can drive up to 700 mA of current. However, the sum of all output currents must not exceed 2 A.

## Basic Circuit

The following image shows the basic internal circuit of the Digital I/O interface:

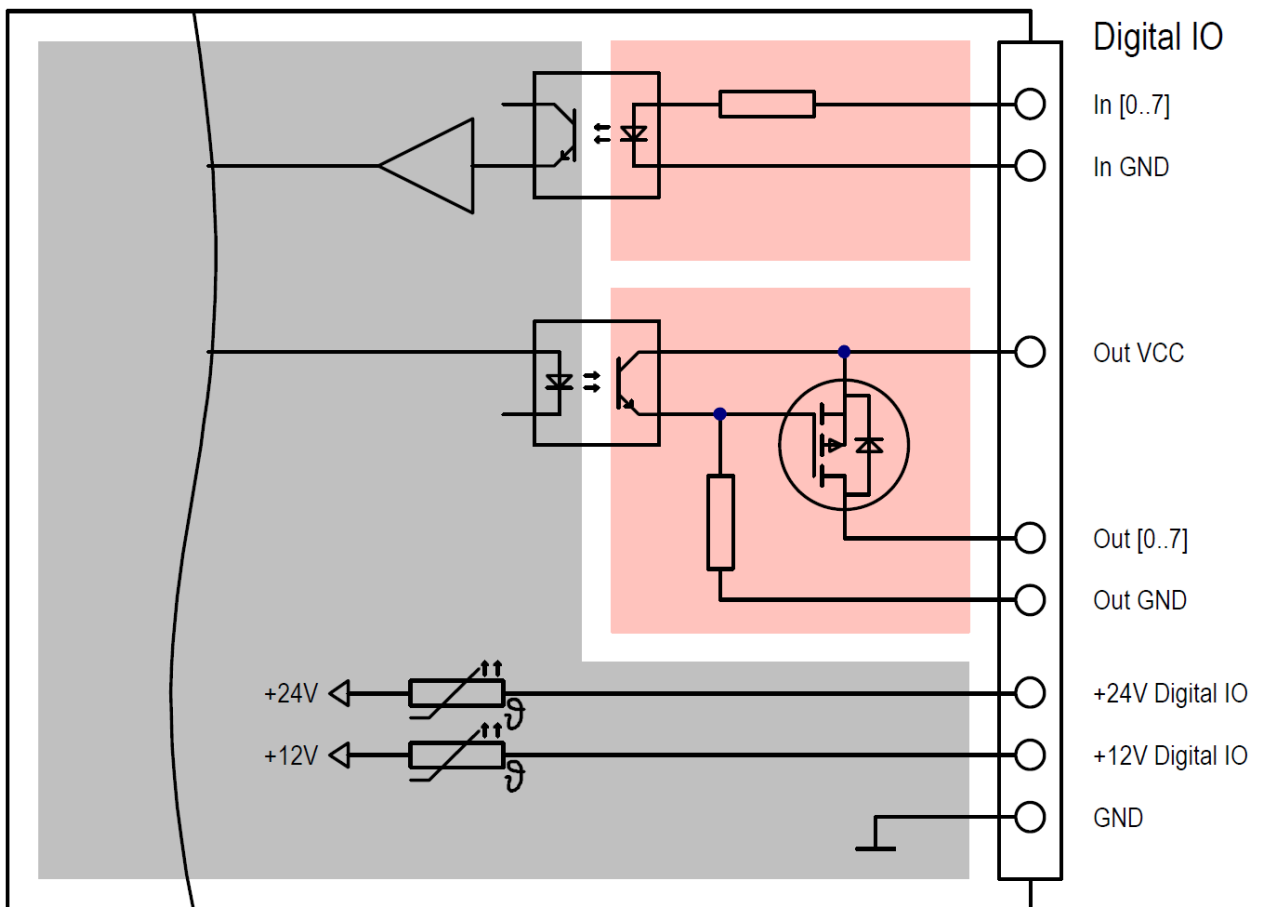

## Pin Assignment

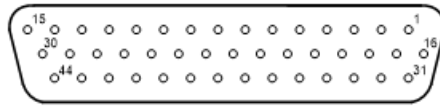

D-Sub HD 44-Pin Female Connector (viewed from the front)

Pin Number	Name	Description	Type	Level
16	In 0	Input 0	I	24 V
31	In 1	Input 1	I	24 V
1	In 2	Input 2	I	24 V
17	In 3	Input 3	I	24 V
32	In 4	Input 4	I	24 V
2	In 5	Input 5	I	24 V
18	In 6	Input 6	I	24 V
33	In 7	Input 7	I	24 V
3	In GND	Reference potential for the inputs	I	0 V
19	Out 0	Output 0	O	Out VCC
34	Out 1	Output 1	O	Out VCC
4	Out 2	Output 2	O	Out VCC
20	Out 3	Output 3	O	Out VCC
35	Out 4	Output 4	O	Out VCC
5	Out 5	Output 5	O	Out VCC
21	Out 6	Output 6	O	Out VCC
36	Out 7	Output 7	O	Out VCC
22	Out GND	Mass/reference potential for the 24 V outputs.	I	0 V
6	Out VCC	Supply voltage for the outputs.	I	12-24 V
39	+24 V Digital IO	24 V output (max. 1 A)	O	24 V
9	+12 V Digital IO	12 V output (max. 1 A)	O	12 V
15 37 41 42	GND	Reference potential for the power supply outputs.	O	
12	reserved	Do not wire this pin.	R	
28	reserved	Do not wire this pin.	R	
43	reserved	Do not wire this pin.	R	
13	reserved	Do not wire this pin.	R	

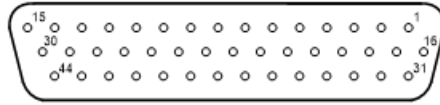

D-Sub HD 44-Pin Female Connector (viewed from the front)

Pin Number	Name	Description	Type	Level
29	reserved	Do not wire this pin.	R	
44	reserved	Do not wire this pin.	R	
14	reserved	Do not wire this pin.	R	
30	reserved	Do not wire this pin.	R	
26	reserved	Do not wire this pin.	R	
10	reserved	Do not wire this pin.	R	
27	reserved	Do not wire this pin.	R	
11	reserved	Do not wire this pin.	R	
7	-	Not connected.	NC	
8	-	Not connected.	NC	
23	-	Not connected.	NC	
24	-	Not connected.	NC	
25	-	Not connected.	NC	
38	-	Not connected.	NC	
40	-	Not connected.	NC	

### Connection Example

The following image shows an example of the connecting the inputs of the Digital I/O interface with an external supply.

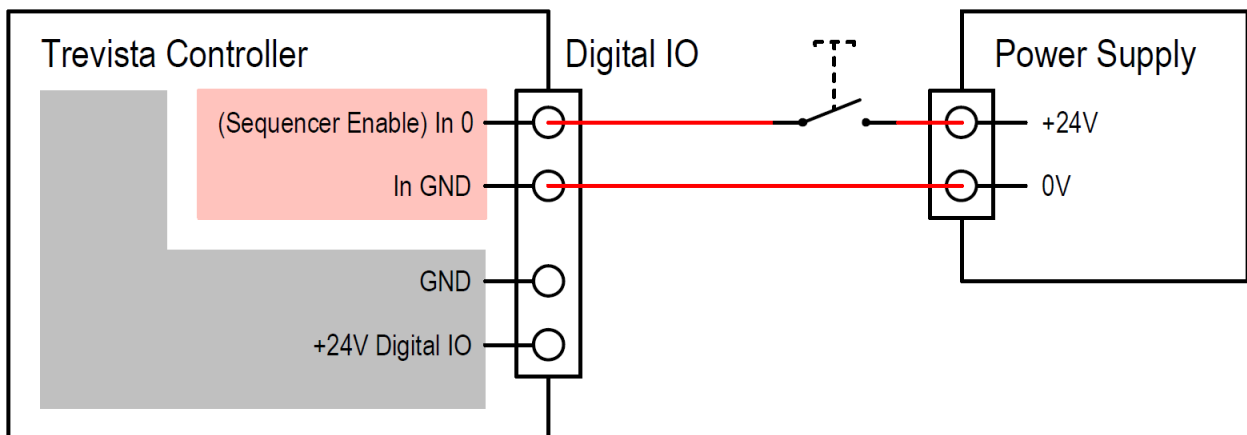

The following image shows an example of the connecting the inputs of the Digital I/O interface with the internal supply.

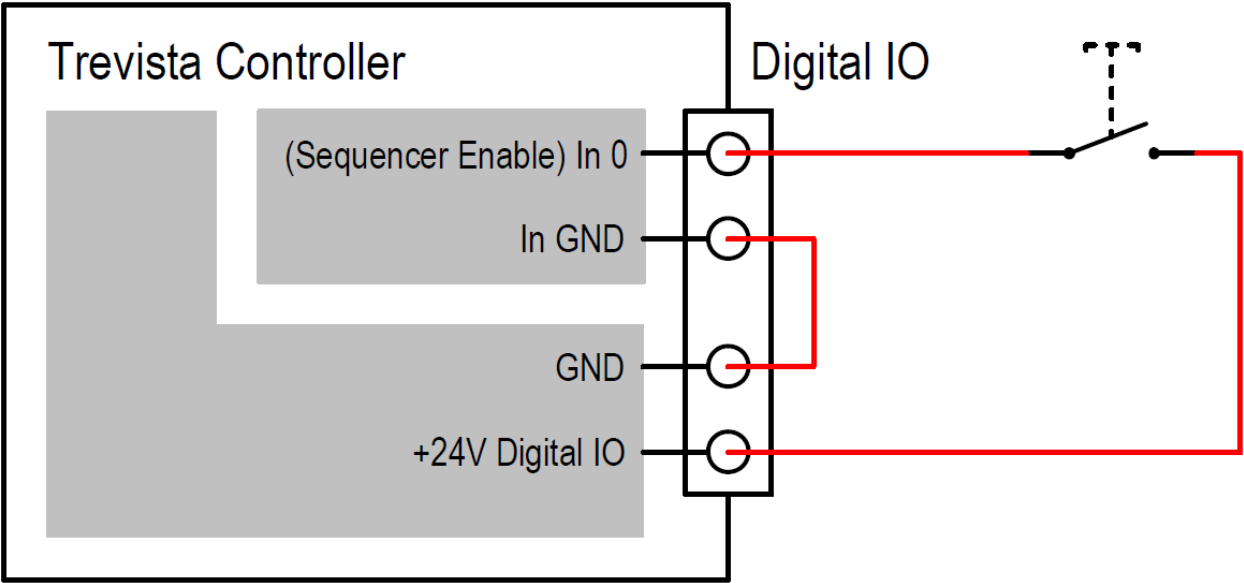

The following image shows an example of the connecting the outputs of the Digital I/O interface with an external supply.

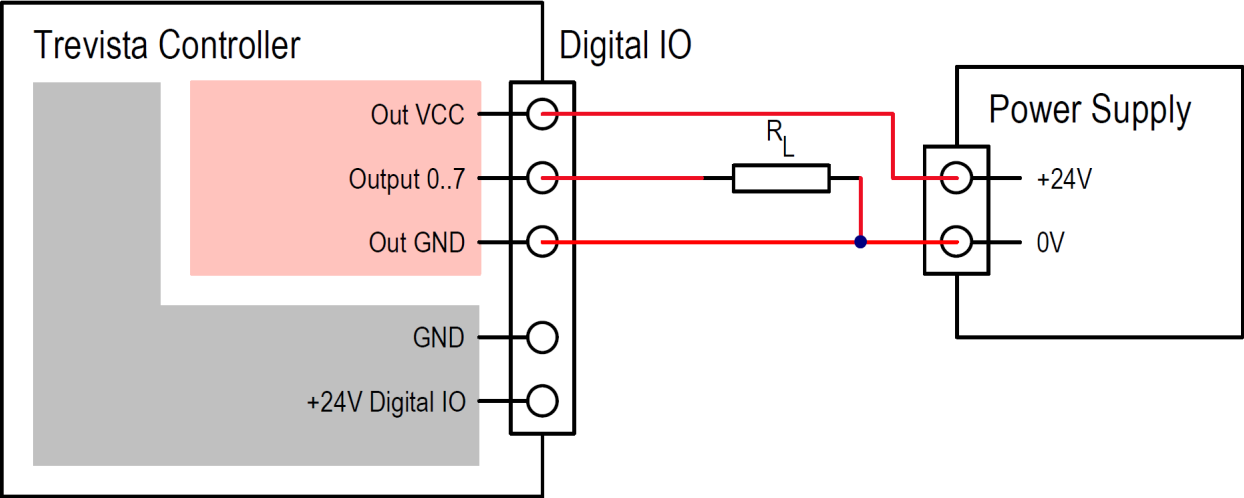

The following image shows an example of the connecting the outputs of the Digital I/O interface the internal supply.

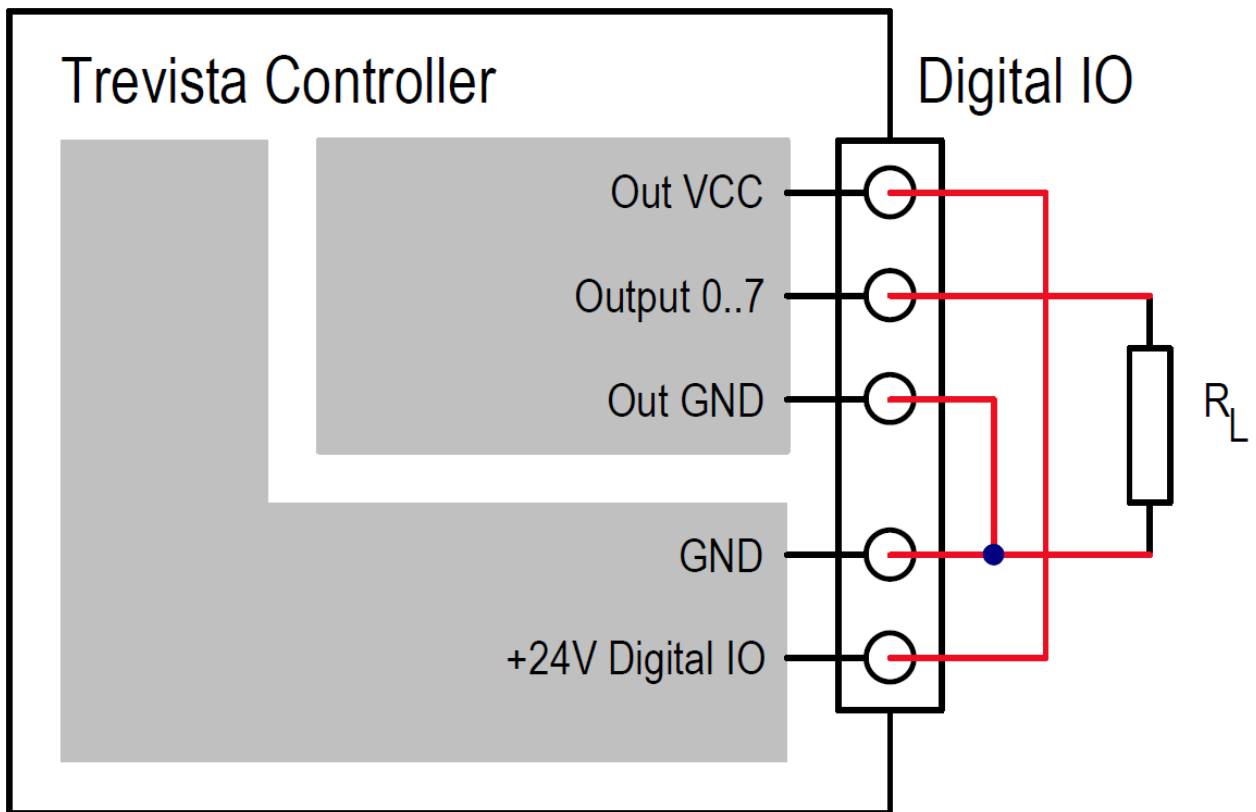

### Electrical Data

Output (Output 0..7)

Parameter	Test Condition	Minimum	Typical	Maximum	Unit
Output current per output				0.7	A
Sum of the currents across all outputs				2	A
Output voltage	Out VCC = 24V, I <sub>Out</sub> = 0.7 A	23.5	23.8		V
Input voltage at Out VCC		11		25	V

Input (Input 0..7)

Parameter	Test Condition	Minimum	Typical	Maximum	Unit
Input voltage for low level				4	V
Input voltage for high level		16		25	V
Input current	U <sub>Input</sub> = 24 V		4	10	mA

+12 V supply output (+12 V Digital IO)

Parameter	Test Condition	Minimum	Typical	Maximum	Unit
Output voltage	I <sub>Out</sub> = 0 A	11.5	12	12.5	V
	I <sub>Out</sub> = 1 A	11.3		12.4	
Output current				1	A

+24 V supply output (+24 V Digital IO)

Parameter	Test Condition	Minimum	Typical	Maximum	Unit
Output voltage	$I_{Out} = 0 \text{ A}$	23.2	24	24.8	V
	$I_{Out} = 1 \text{ A}$	23		24.6	
Output current				1	A

## Encoder

You can connect an incremental encoder (rotary encoder / glass scale) to the Dome controller through the encoder interface.

The interface provides 5 V and 24 V outputs for the voltage supply of the encoder.

**Note:** You must only use the power supply outputs to supply the encoder.

The encoder inputs (A+, A-, B+, B-) are galvanically isolated. When using encoders with ground-referenced A/B signals, this galvanic isolation is lost.

**Note:** Cognex recommends using our programmable encoders, with which you can set the number of pulses per revolution through the Dome controller.

## Basic Circuit

The following image shows the basic internal circuit of the encoder interface:

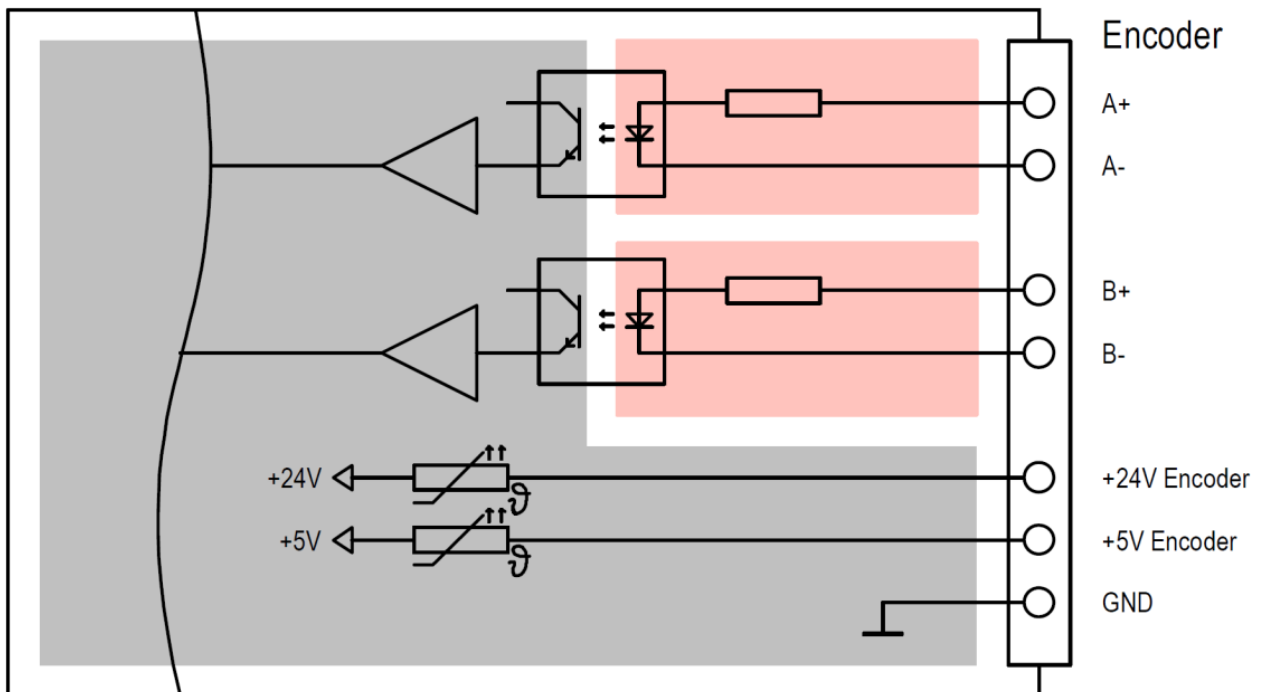

## Pin Assignment

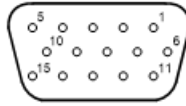

D-Sub 15-Pin Female Connector (viewed from the front)

Pin Number	Name	Description	Type	Level
12	A+	Encoder input A+	I	5-24 V
2	A-	Encoder input A-	I	5-24 V
8	B+	Encoder input B+	I	5-24 V
13	B-	Encoder input B-	I	5-24 V
7	GND	Mass/reference potential for the power supply outputs, encoder inputs, and RS-485.	O	
5	+24 V Encoder	24 V output for the encoder power supply (max. 0.5 A).	O	24 V
15	+5 V Encoder	5 V output for encoder power supply (max. 1 A).	O	5 V
6	reserved	Do not wire this pin.	R	
11	reserved	Do not wire this pin.	R	
1	-			
3	-			
4	reserved	Do not wire this pin.	R	
9	reserved	Do not wire this pin.	R	
10	-			
14	-			

## Connection Example

The following image shows an example of a differential connection to the encoder interface.

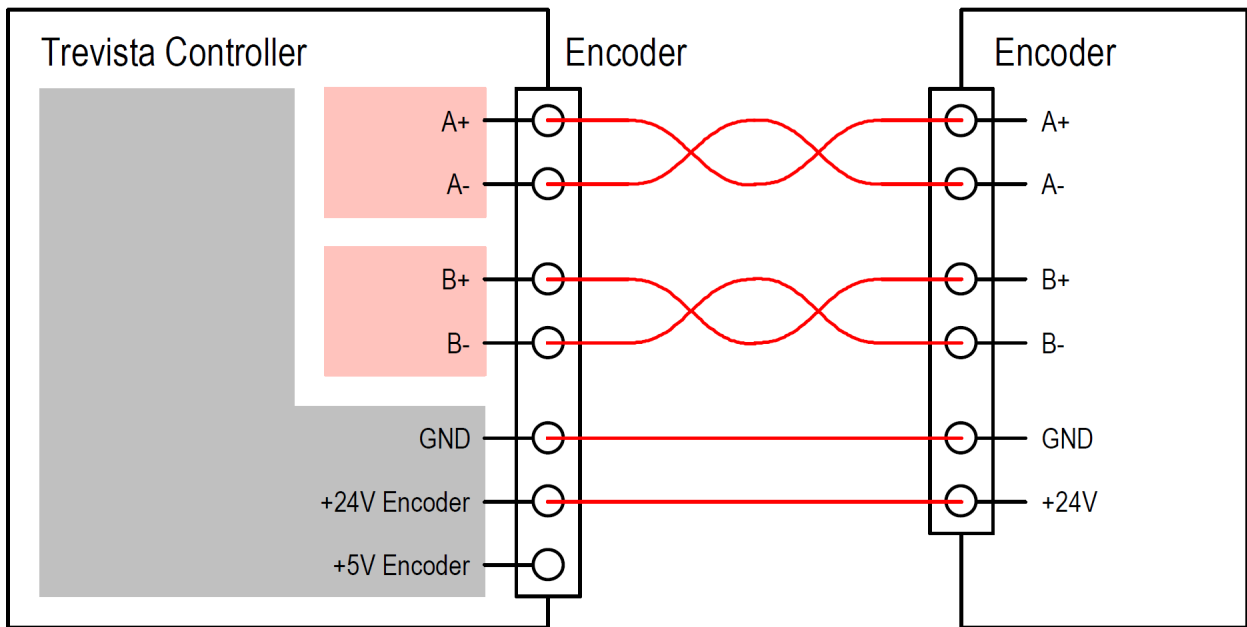

The following image shows an example of a ground-referenced connection to the encoder interface.

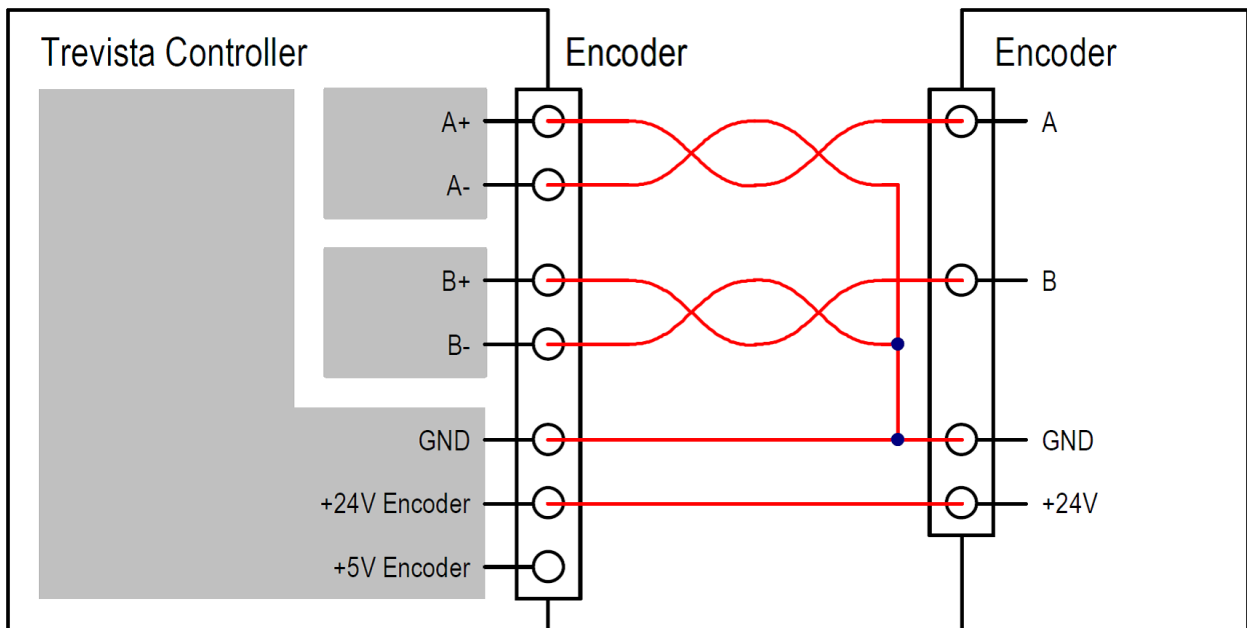

## Electrical Data

Encoder input (A/B +/-)

Parameter	Test Condition	Minimum	Typical	Maximum	Unit
Differential input voltage for low level	A+ - A- or B+ - B-	-25		1	V
Differential input voltage for high level	A+ - A- or B+ - B-	4.5		25	V

Input current	$U_{Diff} \leq 1 \text{ V}$		0	0	mA
	$U_{Diff} = 5 \text{ V}$		6	10	
	$U_{Diff} = 12 \text{ V}$		7	10	
	$U_{Diff} = 24 \text{ V}$		7	10	

+5 V supply output (+5 V Encoder)

Parameter	Test Condition	Minimum	Typical	Maximum	Unit
Output voltage	$I_{Out} = 0 \text{ A}$	4.7	5	5.3	V
	$I_{Out} = 1 \text{ A}$	4.6		5.2	
Output current				1	A

+24 V supply output (+24 V Encoder)

Parameter	Test Condition	Minimum	Typical	Maximum	Unit
Output voltage	$I_{Out} = 0 \text{ A}$	23.2	24	24.8	V
	$I_{Out} = 0.5 \text{ A}$	23.1		24.7	
Output current				0.5	A

## Light

You can connect the lights to the Dome controller through the Light interfaces.

### Light 0

Make sure to only connect Cognex trevista® lights to the “Light 0” interface. The light transmits the light data to the Dome controller after you switch on the Dome controller.

The automatic light data of Cognex lights contain the following parameters, among others:

- Nominal current at 100% brightness and 100% calibration
- Maximum current
- Forward voltages with different currents
- Maximum duty cycle and maximum activation time of the light with different currents
- Position of the light channel inside the Trevista CI Dome
- Temperature sensor type and position inside the light

### Light 1 and Light 2

**Note:** The “Light 1” and “Light 2” interfaces are only available with hardware version 1 or later.

You can connect any LED lights that meet the following criteria to the “Light 1” and “Light 2” interfaces:

- The light must provide the LED connections directly and must not contain a ballast.

**Note:** The output drivers of the “Light 1” and “Light 2” interfaces are pure sources of electricity. Operating a light that requires constant voltage or a light with an electrical ballast can lead to the destruction of the Dome controller or the light.

- The operating voltage of the light including cable (measured at the Dome controller connector) at maximum current is less than 35 V.
- The operating current of the light is between 200 mA and 10 A.

**Note:** Connecting lighting with a capacitive or an inductive impedance can lead to the destruction of the Dome controller or the lighting.

For *trevista*® lights not manufactured by Cognex, you must enter the light parameters manually. These are limited to the following parameters:

- Nominal current at 100% brightness and 100% calibration
- Maximum current

To connect a light to the “Light 1” or “Light 2” interface:

1. Configure the Dome controller before connecting a light, using the Cognex device configurator.
  - a. Set the **Light data** parameter to **manual**. For more information, see chapter 10.5.2 Light (XREF NEEDED).
  - b. Enter the maximum current with which the lighting can permanently operate in the **Maximum current** parameter. The maximum current must be greater than or equal to the nominal current. For more information, see chapter 10.5.2 Light (XREF NEEDED).
  - c. Enter the nominal current of the lighting in the **Nominal current** parameter. The nominal current must be less than or equal to the maximum current and refers to a brightness setting of 100%. For more information, see chapter 10.5.2 Light (XREF NEEDED).
  - d. Save the settings as initial state in the device.
2. Turn off the Dome controller.
3. Connect the light.
4. Turn on the Dome controller.

## Training Sequence

After switching on, the Dome controller automatically runs a training sequence for every light channel to determine the lighting voltages at nominal current and at maximum current. If necessary, the Dome controller reduces the maximum brightness and consequently the maximum current if the maximum current cannot be reached.

**Note:** Make sure to determine the correct values for the **Light data**, **Maximum current**, and **Nominal current** parameters, and save them as initial state with the Cognex device configurator before you turn on the Dome controller

If you want to operate a light with manual light data, you make sure to determine the light data (especially **Maximum current**) correctly and save as initial state before connecting the light to the controller. Otherwise, the light could be destroyed.

### CAUTION:



It is your responsibility to enter correct light data when configuring the device manually. Cognex does not assume liability for damages and operational disruptions.

**Note:** The Dome controller always uses the data of Cognex lights with light data can be read out digitally. The Dome controller ignores manual data even when the parameter **Light data** is set to **Manual**.

## Current and Voltage Monitoring

**Note:**

The Dome controller may perform a power limitation to prevent destruction from excessive power loss. This is accomplished by reducing the maximum pulse-break ratio from 100% to smaller values.

**Note:** You can monitor the maximum activation time and the maximum pulse-break ratio for the current configuration with the **Maximum activation time** and **Maximum duty cycle** parameters of each lighting channel. For more information, see chapter 10.5.2 Light (XREF NEEDED).

Higher operating voltages of the light (30-35 V) lead to less power dissipation of the Dome controller, especially in connection with higher currents. This also results in a higher maximum duty cycle and higher maximum activation time.

The Dome controller monitors the LED current and voltage both in the on and off state, separately for each light channel. The sampling interval is approximately 20  $\mu$ s. The Dome controller can only monitor states that last longer than the sampling interval.

If the determined current or voltage is not within the expected value range, it leads to errors or warnings.

In an error state, all light channels are switched off and the power supply of all LED drivers is deactivated in order to prevent damage to the Dome controller and to the light. You can only exit this state by restarting the Dome controller.

The following errors can occur during current and voltage monitoring:

- Overcurrent in switched-on state – the current is higher than the selected nominal value. The display shows an error notification, for example *Led driver 2: LOC2: Overcurrent*.
- Fault current in switched-off state – a current is present even though the lighting channel is switched off. The display shows an error notification, for example *Led driver 1: LOC1: Fault current*.
- Error in the LED driver – the voltage drop of the LED driver in switched-on state is too high, which could lead to the destruction of the driver. The display shows an error notification, for example *Led driver 6: L1C0: Mosfet voltage out of range*. This means that the LED voltage is too low, possibly indicating a short circuit.

The following warnings can occur during current and voltage monitoring:

- The current in switched-on state is too low. The display shows an error notification, for example *Led driver 0: LOC0: Current too low. I < Iset*.
- The voltage drop of the LED driver in switched-on state is too low; the current may not be regulated correctly. The display shows an error notification, for example *Led driver 0: LOC0: Low voltage reserve. I incorrect?*

**Note:** Current and voltage monitoring is inactive during activation and deactivation phases with a duration of less than 20  $\mu$ s. The Dome controller cannot detect error or warning states during these phases. Cognex recommends not to fall below an activation or deactivation time of 20  $\mu$ s.

## Basic Circuit

The following image shows the basic circuit of the Light 0 connection (6 LED channels). The connections for Light 1 and Light 2 both have only one LED channel each.

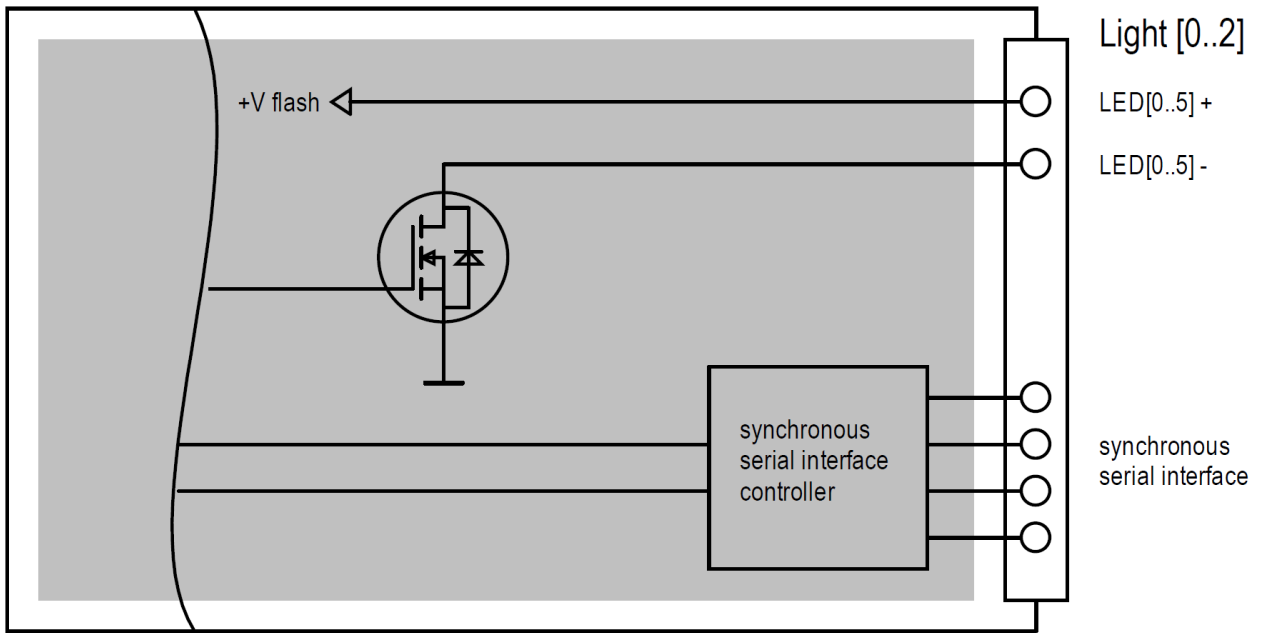

## Pin Assignment

The following table shows the pin assignment of the Light 0 connector:

Pin Number	Name	Description	Type	Level
18 + 19	LED0+	LED channel 0 connection + (to the anode)	O	38 V
36 + 37	LED0-	LED channel 0 connection - (to the cathode)	O	0..38 V
16 + 17	LED1+	LED channel 1 connection + (to the anode)	O	38 V
34 + 35	LED1-	LED channel 1 connection - (to the cathode)	O	0..38 V
14 + 15	LED2+	LED channel 2 connection + (to the anode)	O	38 V
32 + 33	LED2-	LED channel 2 connection - (to the cathode)	O	0..38 V
12 + 13	LED3+	LED channel 3 connection + (to the anode)	O	38 V
30 + 31	LED3-	LED channel 3 connection - (to the cathode)	O	0..38 V
10 + 11	LED4+	LED channel 4 connection + (to the anode)	O	38 V
28 + 29	LED4-	LED channel 4 connection - (to the cathode)	O	0..38 V
8 + 9	LED5+	LED channel 5 Connection + (to the anode)	O	38 V
26 + 27	LED5-	LED channel 5 Connection - (to the cathode)	O	0..38 V
1	reserved	Do not wire this pin.	R	
2	reserved	Do not wire this pin.	R	

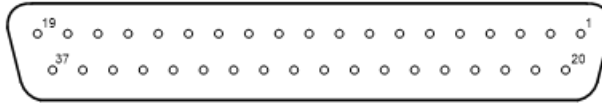

D-Sub 37-Pin Female Connector (viewed from front)

Pin Number	Name	Description	Type	Level
3	reserved	Do not wire this pin.	R	
4	reserved	Do not wire this pin.	R	
5	-			
6	-			
7	-			
20	-			
21	-			
22	-			
23	-			
24	-			
25	-			

The following table shows the pin assignment of the Light 1 and Light 2 connectors:

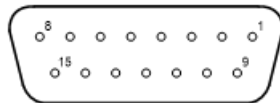

D-Sub 15-Pin Female Connector (viewed from the front)

Pin Number	Name	Description	Type	Level
6 + 7 + 8	LED0+	LED channel 0 connection + (to the anode)	O	38 V
13 + 14 + 15	LED0-	LED channel 0 connection – (to the cathode)	O	0..38 V
1	reserved	Do not wire this pin.	R	
2	reserved	Do not wire this pin.	R	
9	reserved	Do not wire this pin.	R	
10	reserved	Do not wire this pin.	R	
3	-			
4	-			
5	-			
11	-			
12	-			

**Note:** The positive and the negative connections of an LED channel are available through several plug pins. When you connect a light, interconnect these pins within the connector to ensure the equal distribution of current between several pins. For example, Light 1: LED0+: Pin 6 + 7 + 8, LED0-: Pin 13 + 14 + 15.

## Connection Example

The following image shows a connection example for the Light 1 connector:

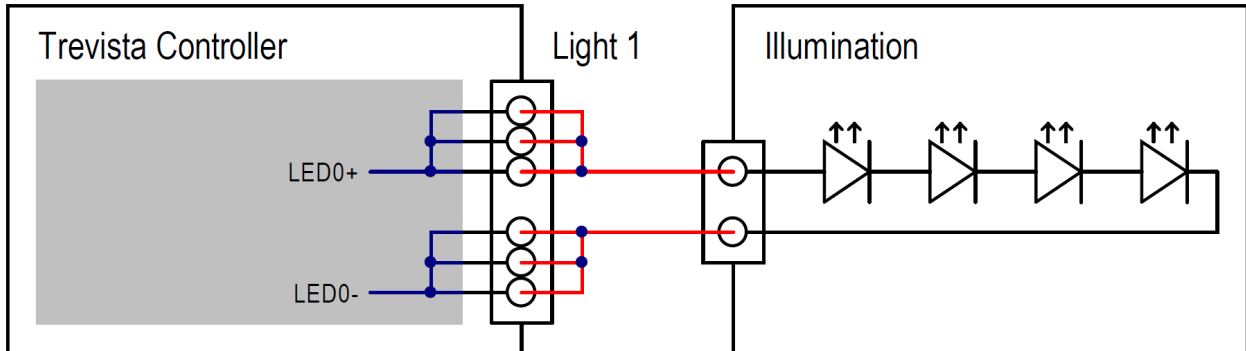

# Operation

## Block Diagram

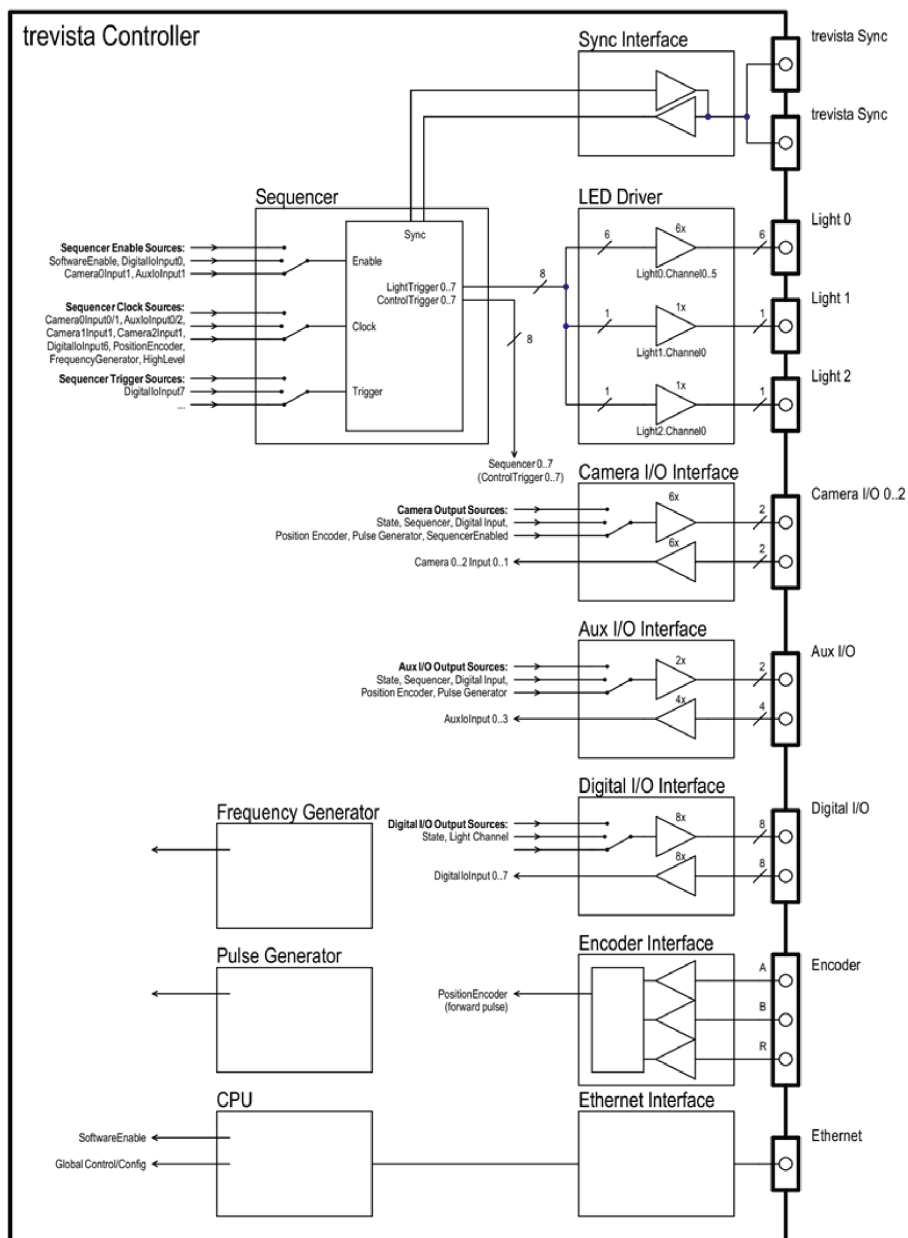

## Power On/Off

The controller is switched on and off with the power switch on the front panel.

After having been switched on, the controller needs some time for self-testing, device identification, and calibration. In this initialization phase, the controller cannot be accessed via software.

You can switch the controller off at any point during operation. Settings that have not been saved as initial state are lost.

## Manual Operation of the Dome

Display and retrieve the operation states and status information using the control elements display, LEDs, and buttons on the front panel.

It is not possible to parameterize the controller with these control elements. Parameterization must be performed with software in the Ethernet interface.

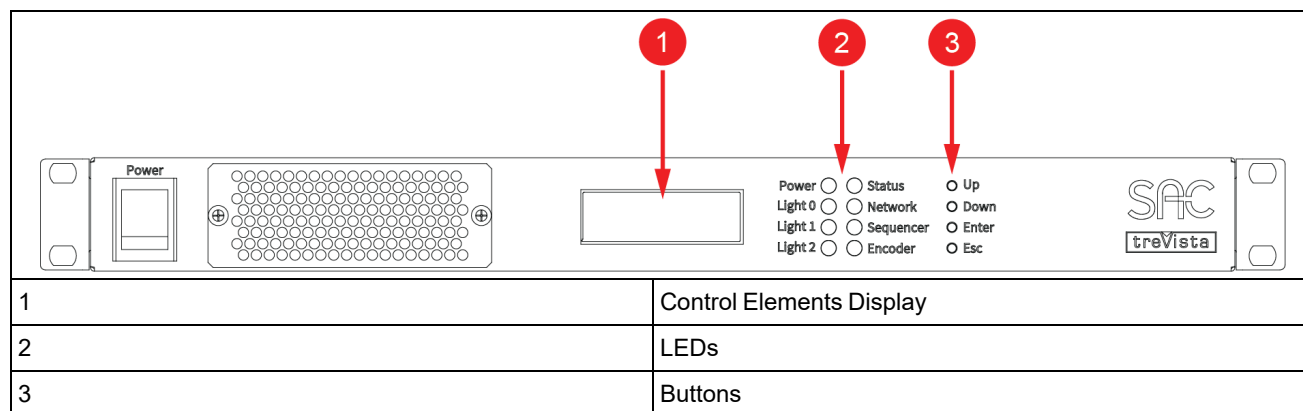

### LEDs

The LEDs on the front panel display current operating states of the controller. The LEDs are two-colored (red and green) and can assume the following states:

- Off
- Permanently green
- Flashing green
- Permanently red
- Flashing red

The following tables explain the individual LEDs and their states:

#### Power LED

State	Meaning
Off	The device is switched off.
Permanently green	The device is switched on.
Permanently red	The supply voltage of the LED drivers ( $\mu\text{F}$ ) is outside the allowable tolerance.

#### Light 0, Light 1, and Light 2 LEDs

State	Meaning
Off	No light is connected.
Permanently green	The light is connected; the training sequence was successful.
Flashing green	The light is switched on.

Permanently red	<p>Critical error.</p> <p>Error types:</p> <ul style="list-style-type: none"> <li>• Incorrect training sequence of an automatic SAC light</li> <li>• Overtemperature of the light (only with automatic SAC lights)</li> <li>• Disconnection of the data interface (with automatic SAC lights)</li> <li>• Overcurrent (in switched-on state)</li> <li>• Fault current (in switched-off state)</li> <li>• Errors in the LED driver</li> </ul>
Flashing red	<p>Uncritical error.</p> <p>Error types:</p> <ul style="list-style-type: none"> <li>• Duty cycle limit active</li> <li>• Lighting channel overtriggered LED current lower than nominal current</li> <li>• Voltage reserve in LED driver low, LED current possibly wrong</li> <li>• Power limitation active (The sum of currents of the switched-on lighting channels exceeds the maximum current that the controller can provide.)</li> </ul>

### Status LED

State	Meaning
Off	The device is starting; initialization phase
Flashing green (slow)	Normal state; no communication
Flashing green (fast)	Normal state; device communicates
Permanently red	Error during initialization

### Network LED

State	Meaning
Off	No network cable connected
Permanently green	Network cable connected
Flashing green	Data transfer via the network cable

### Sequencer LED

State	Meaning
Off	Sequencer not enabled
Permanently green	Sequencer enabled; waiting for sequencer trigger or sequence terminated
Flashing green	Sequencer enabled

Flashing red	<p>Error.</p> <p>Error types:</p> <ul style="list-style-type: none"> <li>• Camera I/O 0 Output 0 is overtriggered.</li> <li>• Camera I/O 1 Output 0 is overtriggered.</li> <li>• Camera I/O 2 Output 0 is overtriggered.</li> <li>• Aux I/O output 0 is overtriggered.</li> <li>• Aux I/O output 1 is overtriggered.</li> </ul>
--------------	---

### Encoder LED

State	Meaning
Off	No programmable encoder connected
Permanently green	Programmable encoder connected
Flashing green	Positive edge(s) at the encoder clock detected (after preprocessing and clock adjustment)
Permanently red	Disconnection of the data interface (cable disconnected, cable or encoder defective)





## Display

The display shows operating states and status information. Beside the standard display, error and warning notifications are also shown. You can open a menu to find further information with the buttons.

The following chapters explain the individual display elements. When the individual display rows (1-4) are referenced, the row with the number 1 is the top row, while the row with the number 4 is the bottom row.

### Symbols for Displaying States and Signal State Changes

In certain areas of the display, states and state changes of signals are shown.

Symbol	Meaning
	Signal state "Low"
	Signal state "High"
	Signal state change from "High" to "Low"
	Signal state change from "Low" to "High"
	Multiple signal state changes

## Standard Display

The standard display is active after the startup/initialization phase. You can return to this display anytime by pressing the “ESC” button (repeatedly).

Row	Content
2	<div data-bbox="509 302 1025 474" style="border: 2px solid black; padding: 5px; margin-bottom: 10px;"> <pre>trevista controller Sequencer: disabled f: 28.3 Hz ? Tc:27.8°C Tl:34.5°C</pre> </div> Sequencer state: <ul style="list-style-type: none"> <li>• “disabled” – The sequencer is disabled.</li> <li>• “trigger ?” – The sequencer is enabled and is waiting for a trigger.</li> <li>• “active” – The sequence is being processed.</li> <li>• “complete” – The sequencer has processed the last sequence step.</li> </ul>
3	Frequency of the sequencer clock. If there is a question mark at the end of the row, no frequency could be determined during the last sampling interval and the last determined frequency is displayed.
4	Temperatures of the controller (Tc) and the light (Tl). Since the controller has several temperature sensors, only the highest value is displayed here. Accordingly, only the highest temperature of all lights and light channels is displayed. You can find the measured values of all sensors via the menu with the menu items “Controller temp.” and “Light temp.”.

## Error and Warning Notifications

Error and warning notifications are always displayed in the foreground, regardless of the current display state. Warning notifications disappear again after 5 seconds. Error notifications are displayed until the error has ceased to exist (such as when the temperature has fallen again after an overtemperature error) or until the error has been acknowledged by pressing the “ESC” button.

After acknowledging the error, the display is set back to the last selected display mode. All error and warning notifications are also logged in the “event log” (see chapter “Menu item “Event log””).

Row	Content
1	<div data-bbox="243 1352 760 1524" style="border: 2px solid black; padding: 5px; display: inline-block; margin-right: 20px;"> <pre>- Warning - LedChannel2: Dutycycle limited</pre> </div> <div data-bbox="773 1352 1290 1524" style="border: 2px solid black; padding: 5px; display: inline-block;"> <pre>- Error - Light0: Ch2 training error!</pre> </div> Notification type: <ul style="list-style-type: none"> <li>• Warning</li> <li>• Error</li> </ul>

2	Module: <ul style="list-style-type: none"> <li>• LedDriver</li> <li>• LedPower</li> <li>• Fan</li> <li>• Light</li> <li>• Cameralo</li> <li>• Auxlo</li> <li>• Encoder</li> <li>• ...</li> </ul>
3 - 4	Notification text

## Menu

After pressing the “Up” or “Down” button, the menu opens. If no button is pressed for 10 seconds or the “ESC” button is pressed, the menu is closed, and the display is set back to the standard display.

The small arrow left of the menu entries shows the current selection. You can switch between the entries with the “Up” and “Down” buttons. Open the selected menu item by pressing the “Enter” button.

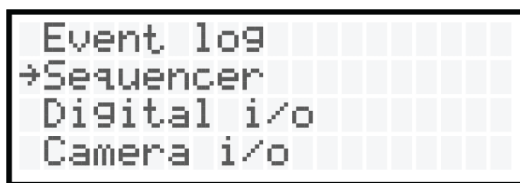

## Event Log

The controller saves all notifications in a permanent memory (this function is only available from hardware version 1.) The device can log a maximum of 8,000 notifications before the oldest notification is overwritten again. These notifications can be found in the menu item “Event Log”.

After opening the “Event Log”, the latest notification is displayed. With the “Down” button you can scroll to older notifications. With the “Up” button you can scroll to newer notifications.

## Notification Types

- Info - General information
- Warning - Warning notifications
- Error - Error notifications
- ErrorRelease - Withdrawn error messages

<pre> I 0191 T0000387022 Light0: Temperature: T0=24C T1=23C T2=24C T3=25C         </pre>	<pre> W 0192 T0000387024 Light0: Ch1 overtemperature T=92 C         </pre>
<pre> E 0193 T0000489042 Fan1: Low rotational speed         </pre>	<pre> ER 0194 T0000498402 Fan1: Low rotational speed         </pre>
Row	Content
2	Left - Notification type: <ul style="list-style-type: none"> <li>• I = Information</li> <li>• W = Warning (warning notification)</li> <li>• E = Error (error notification)</li> <li>• ER = ErrorRelease (withdrawn error message)</li> </ul> Center - Notification number (continuous, hexadecimal) Right - Time stamp in milliseconds; 0 = controller starting time. After 4,294,967,295 milliseconds, it is reset to 0.
2	Module
3 - 4	Notification text

### Sequencer

The menu item Sequencer shows the operating state of the sequencer. When the sequences are processed very fast, it is possible that the display is refreshed too slowly to display all state changes of the sequencer. However, this does not impair the functionality of the sequencer.

<pre> - Sequencer - Enable: ~ Trigger: _ Clk: \$ f: 18.9Hz ? State: complete         </pre>	
Row	Content
2	Left - State of the sequencer enable signal Right - State of the sequencer trigger signal (only relevant when the trigger is activated)
3	Left - State of the sequencer clock signal Right - Frequency of the sequencer clock signal. If there is a question mark at the end of the row, no frequency could be determined during the last sampling interval, and the last determined frequency is displayed.
4	Sequencer state: <ul style="list-style-type: none"> <li>• “disabled” – The sequencer is disabled.</li> <li>• “trigger ?” – The sequencer is enabled and is waiting for a trigger.</li> <li>• “step 0..N” – The sequence is being processed. The current sequence step is displayed.</li> <li>• “complete” – The sequencer has processed the last sequence step.</li> </ul>

### Digital I/O

The menu item “Digital i/o” shows the states of the input and output signals of the Digital I/O interface.

	
Row	Content
4	Left - State of the digital inputs 0 to 7 Right - Status of the digital outputs 0 to 7

### Camera I/O

The menu item “Camera i/o” shows the states of the input and output signals of the Camera I/O interface. You can switch between the three Camera I/O interfaces with the “Up” and “Down” buttons.

	
Row	Content
1	Selected interface – “Camera I/O” 0/1/2
2	State input 0 / output 0
3	State input 1 / output 1

### Aux I/O

The menu item “Aux i/o” shows the states of the input and output signals of the Aux I/O interface.

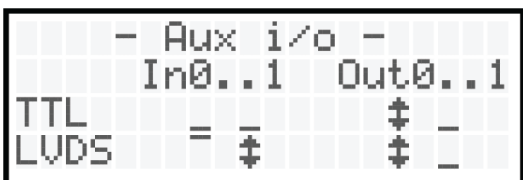
	
Row	Content
3	Left - States of the TTL inputs 0-1 Right - States of the TTL outputs 0-1
4	Left - States of the LVDS inputs 0-1. Right - States of the LVDS outputs 0-1.

### Encoder

In the menu item “Encoder”, you can find information on the signals of the incremental encoder and on the processing of these signals.

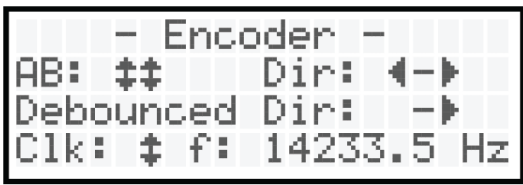
Row	Content
	
2	Left - States of the incremental encoder signals A and B Right - Direction of movement after the functional block "Preprocessing" (direction reversal, quarter increments / full increments, and divider). A left arrow means backward; a right arrow means forward.
3	Direction of movement after the functional block "Direction debounce". A left arrow means backward; a right arrow means forward.
4	State and frequency of the "Position encoder clock" signal after the functional block "Clock adjustment" (direction debounce and direction)

### Light Channels

This menu item shows information on the selected light channel. You can switch between the eight light channels (Light0 Channel 0..5, Light1 Channel 0, and Light2 Channel 0) with the "Up" and "Down" buttons.

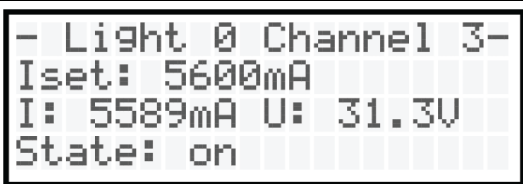
Row	Content
	
2	Nominal current
3	Actually measured current and measured voltage during the last sampling interval with switched-on light channel. When the activation time is very short (< approx. 20 μs), no values can be measured. In this case, a question mark is displayed instead of the value.
4	Light state (on/off)

### Controller Temperature

In the menu item "Controller temp.", you can find the measured values of the temperature sensors of the controller.

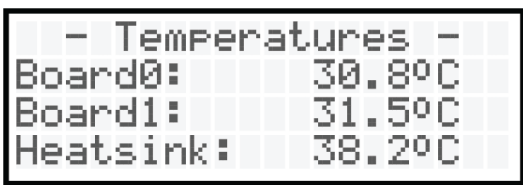
Row	Content
	
2	Board temperature of the LED drivers 0-3 (Light 0 channel 0..3)
3	Board temperature of the LED drivers 4-7 (Light 0 channel 4..5, Light 1 channel 0, Light 2 channel 0)
4	Temperature of the heat sink

### Light Temperature

In the menu item “Light temp.”, you can find the measured values of the temperature sensors of the lights, if available.

For each sensor, the following states can be displayed:

- Temperature (°C)
- “NA” – No sensor available
- “INV” – Measured value invalid
- “ERR” – Error while reading out the sensor

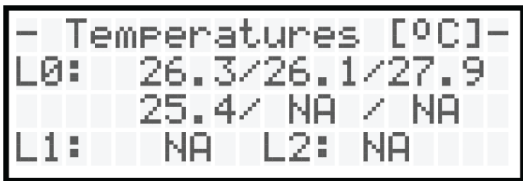
	
Row	Content
2	Measured values of the temperature sensors of light 0 channel 0..2
3	Measured values of the temperature sensors of light 0 channel 3..5
4	Measured values of the temperature sensors of light 1 channel 0 and light 2 channel 0

### Fans

The menu item “Fans” shows the current rotation speed of the fans in rounds per minute (rpm) and as a percentage of the maximum speed. The maximum rotation speed is approximately 17,000 rpm.

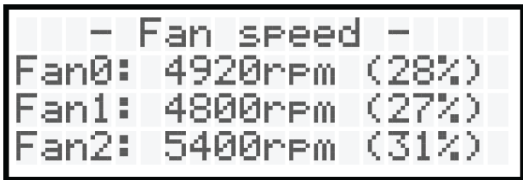
	
Row	Content
2	Rotation speed Fan 0 (rear side of the device / heat sink)
3	Rotation speed Fan 1 (front side of the device / air filter left)
4	Rotation speed Fan 2 (front side of the device / air filter right)

### Firmware Version

The menu item “Firmware version” shows information on the firmware version of the controller.

	
Row	Content
2	Firmware version
3	Device type – “trevista controller”

4	Device Mode: <ul style="list-style-type: none"> <li>• Surface (trevista® DOME Standard)</li> <li>    Cylinder (trevista® DOME Scan)</li> <li>    Multiline (trevista® DOME Scan Multiline)</li> </ul>
---	---

### Device Information

In the menu item “Device information”, you can find the IP address, the serial number, the device ID, the hardware version, and the supply voltage of the LED drivers. The information does not fit on one display page. You can switch between the entries with the “Up” and “Down” buttons.

	
Row	Content
1	Current IP address
2	Serial number of the controller
3	Device ID (adjustable via the rotary encoding switch at the rear side of the device)
4	Hardware version

After pressing the "Down" button:

	
Row	Content
1 - 2	See above (row 3-4)
3	Mainboard version
4	Supply voltage of the LED drivers

### Light Information

In the menu item “Light information”, you can view information on the connected lights. The information includes the name of the light, the serial number, and the number of channels used. Light 0 may have up to 6 channels. Lights 1 and 2 only have one channel each.

Using the “Up” and “Down” keys, you can switch between the three lights.

**Note:** “Light information” only displays data of automatic SAC lights. If no light or any other light is connected, the name of the light is displayed as “name not available”, while the serial and the channel number are both 0.

<pre> - Light 0 -   Dome 20.4 V1 3m SN:      40000155 Channel count: 4           </pre>	
Row	Content
2	Name of the light
3	Serial number
4	Number of channels

### Operating Time

In the menu item “Operating time”, you can find the operating times of the controller.

<pre> - Operating time - Total:      167d:17h PowerUp:    0h:20m:59s            1259s           </pre>	
Row	Content
2	Operating hours count (this count is not lost, even if the controller is switched off)
3	Time after the last switching-on in hours, minutes, and seconds. The count is reset after 1193 hours, 2 minutes, and 47 seconds.
4	Time after the last switching-on in seconds. The count is reset after 4,294,962 seconds. This time is used as the time stamp for the “Event log” notifications.

### Feature Groups

In the menu item “Feature Groups”, you can check which feature groups are enabled. Disabled feature groups are indicated by a 0. Enabled feature groups are indicated by a 1. If necessary, you can check for further enabled feature groups by pressing the “Down” key.

<pre> Light 0 custom: 0 Light/CameraIo 1/2:1 Advanced Sequencer:0 SAC:           0           </pre>	
Row	Content
1 - 4	Feature groups

## Network Operation of the Dome

The IP address of the controller depends on the rotary coding switch “ID” on the rear panel.

The following table shows the relationship between the position of the rotary coder switch and the static IP address of the controller:

Switch Position	IP Address
0 (default)	10.1.1.1

1	10.1.1.2
2	10.1.1.3
3	10.1.1.4
4	10.1.1.5
5	10.1.1.6
6	10.1.1.7
7	10.1.1.8
8	192.168.32.1
9	192.168.32.2
A	192.168.32.3
B	192.168.32.4
C	192.168.32.5
D	192.168.32.6
E	192.168.32.7
F	192.168.32.8

When more controllers are operated in a network, a different IP address must be set for each controller. Operating more than eight controllers in a network is not possible.

#### Required Network Settings on the Host (PC)

IP address: 10.1.0.1-254; 10.1.2-254.1-254 or 192.168.0-31.1-254; 192.168.33-254.1-254

Subnet mask: 255.255.0.0

Protocol: Internet protocol version 4 (TCP/IPv4)

## Image-Processing Software SAC VisionPro®

The image-processing software SAC VisionPro® fully integrates trevista® DOME. All device parameters can be accessed via the device manager. All settings can be saved in the environment of VisionPro®. Permanently saving settings in the device memory of the controller is not possible and not necessary. When VisionPro® is started, the illumination unit is automatically parameterized with the values saved in the environment.

Operating the controller in connection with VisionPro® is explained in the VisionPro® documentation.

## SAC Device Configurator

With the "SAC Device Configurator" software, the controller can be parameterized independently of the image-processing software in use.

Among other things, the SAC Device Configurator enables you to do the following:

- Accessing all controller parameters
- Saving the current settings in the device memory (These settings are loaded the next time the controller is started.)
- Saving the current settings in a file
- Loading settings from a file

- Loading the factory settings of the controller
- Updating the firmware of the trevista® controller

Operating the controller in connection with the SAC Device Configurator is explained in the SAC Device Configurator documentation.

# Care and Maintenance

Disconnect the power supply from the IEC socket of the Trevista controller before performing any care and maintenance work. Contact your Cognex sales representative for any maintenance not described in this section.

## Cleaning

Clean the surfaces of the Trevista CI Dome and controller with a moist cloth to remove dust and dirt.

**⚠ CAUTION:** Never use thinners, gasoline or other chemicals. Do not use compressed air to clean any components.

## Replacing the Fuses

A Trevista controller requires two miniature fuses of type "T 5A H 250V", located in the fuse drawer above the IEC socket on the rear panel. Refer to the section [Controller Layouts on page 29](#) for the location of the IEC socket.

**ⓘ Note:** Use only fuses of type "T 5A H 250V". Contact your Cognex sales representative for ordering information. In addition, Cognex recommends you always replace both fuses at the same time.

Perform the following steps to replace the fuses:

1. Disconnect the Trevista controller from the power supply.
2. Remove the fuse drawer from the base of the fuse holder by pressing the two locking tabs of the drawer from the outside inwards.



3. Replace the existing fuses with the new fuses:



4. Put the fuse drawer back into the base of the fuse holder. The two locking tabs of the drawer must engage audibly in the base.



# Regulations and Conformity

**Note:** For the most current CE and UKCA declaration and regulatory conformity information, see the Cognex support site: [cognex.com/support](http://cognex.com/support).

The Trevista Controller has a Regulatory Model number 50240 and meets or exceeds the requirements of all applicable standards organizations for safe operation. As with any electrical equipment, however, the best way to ensure safe operation is to operate them according to the agency guidelines that follow. Please read these guidelines carefully before using your device.

Safety and Regulatory	
Manufacturer	Cognex Corporation One Vision Drive Natick, MA 01760 USA
<b>CE</b>	Trevista Controller: Regulatory Model 50240 This is a class A product. In a domestic environment this product may cause radio interference in which case the user may be required to take immediate measures. This equipment complies with the essential requirements of the EU Directive 2014/30/EU. Declarations are available from your local representative.
EU RoHS	Compliant to the most recent applicable directive.
FCC	FCC Part 15, Class A This equipment has been tested and found to comply with the limits for a Class A digital device, pursuant to part 15 of the FCC Rules. These limits are designed to provide reasonable protection against harmful interference when the equipment is operated in a commercial environment. This equipment generates, uses, and can radiate radio frequency energy and, if not installed and used in accordance with the instruction manual, may cause harmful interference to radio communications. Operation of this equipment in a residential area is likely to cause harmful interference in which case the user will be required to correct the interference at his own expense.
Korea 	Trevista Controller, KC ID : R-R-CGX-TREVISTA2004 This device is certified for office use only and if used at home, there can be frequency interference problems.
TÜV	Trevista Controller: Regulatory Model 50240
	NRTL: TÜV SÜD SCC/NRTL OSHA Scheme for UL/CAN 61010-1.
	CB report available upon request. TÜV SÜD, IEC/EN 61010-1.
<b>UK CA</b>	Trevista Controller: Regulatory Model 50240 This is a class A product. In a domestic environment this product may cause radio interference in which case the user may be required to take immediate measures. This equipment complies with the essential requirements of the Electromagnetic Compatibility Regulations 2016. Declarations are available from your local representative.

## 中国大陆RoHS (Information for China RoHS Compliance)

根据中国大陆《电子信息产品污染控制管理办法》(也称为中国大陆RoHS), 以下部份列出了本产品中可能包含的有毒有害物质或元素的名称和含量。



	Hazardous Substances 有害物质					
Part Name 部件名称	Lead (Pb) 铅	Mercury (Hg) 汞	Cadmium (Cd) 镉	Hexavalent Chromium (Cr (VI)) 六价铬	Polybrominated biphenyls (PBB) 多溴联苯	Polybrominated diphenyl ethers (PBDE) 多溴二苯醚
Regulatory Model 50240	X	O	O	O	O	O
<p>This table is prepared in accordance with the provisions of SJ/T 11364. 这个标签是根据SJ/T 11364 的规定准备的。</p> <p>O: Indicates that said hazardous substance contained in all of the homogeneous materials for this part is below the limit requirement of GB / T26572 - 2011. 表示本部件所有均质材料中含有的有害物质低于GB / T26572 - 2011 的限量要求。</p> <p>X: Indicates that said hazardous substance contained in at least one of the homogeneous materials used for this part is above the limit requirement of GB / T26572 - 2011. 表示用于本部件的至少一种均质材料中所含的危害物质超过GB / T26572 - 2011 的限制要求。</p>						

## For European Community Users

Cognex complies with Directive 2012/19/EU OF THE EUROPEAN PARLIAMENT AND OF THE COUNCIL of 4 July 2012 on waste electrical and electronic equipment (WEEE).

This product has required the extraction and use of natural resources for its production. It may contain hazardous substances that could impact health and the environment, if not properly disposed.

In order to avoid the dissemination of those substances in our environment and to diminish the pressure on the natural resources, we encourage you to use the appropriate take-back systems for product disposal. Those systems will reuse or recycle most of the materials of the product you are disposing in a sound way.



The crossed out wheeled bin symbol informs you that the product should not be disposed of along with municipal waste and invites you to use the appropriate separate take-back systems for product disposal.

If you need more information on the collection, reuse, and recycling systems, please contact your local or regional waste administration.

You may also contact your supplier for more information on the environmental performance of this product.

