

VisionPro® 3D-L4000 Series Reference Guide



2024 February 27
Revision: 9.21.0.1

Legal Notices

The software described in this document is furnished under license, and may be used or copied only in accordance with the terms of such license and with the inclusion of the copyright notice shown on this page. Neither the software, this document, nor any copies thereof may be provided to, or otherwise made available to, anyone other than the licensee. Title to, and ownership of, this software remains with Cognex Corporation or its licensor. Cognex Corporation assumes no responsibility for the use or reliability of its software on equipment that is not supplied by Cognex Corporation. Cognex Corporation makes no warranties, either express or implied, regarding the described software, its merchantability, non-infringement or its fitness for any particular purpose.

The information in this document is subject to change without notice and should not be construed as a commitment by Cognex Corporation. Cognex Corporation is not responsible for any errors that may be present in either this document or the associated software.

Companies, names, and data used in examples herein are fictitious unless otherwise noted. No part of this document may be reproduced or transmitted in any form or by any means, electronic or mechanical, for any purpose, nor transferred to any other media or language without the written permission of Cognex Corporation.

Copyright © 2023. Cognex Corporation. All Rights Reserved.

Portions of the hardware and software provided by Cognex may be covered by one or more U.S. and foreign patents, as well as pending U.S. and foreign patents listed on the Cognex web site at: cognex.com/patents.

The following are registered trademarks of Cognex Corporation:

Cognex, 2DMAX, Advantage, AlignPlus, Assemblyplus, Check it with Checker, Checker, Cognex Vision for Industry, Cognex VSOC, CVL, DataMan, DisplayInspect, DVT, EasyBuilder, Hotbars, IDMax, In-Sight, Laser Killer, MVS-8000, OmniView, PatFind, PatFlex, PatInspect, PatMax, PatQuick, SensorView, SmartView, SmartAdvisor, SmartLearn, UltraLight, Vision Solutions, VisionPro, VisionView

The following are trademarks of Cognex Corporation:

The Cognex logo, 1DMax, 3D-Locate, 3DMax, BGAll, CheckPoint, Cognex VSoC, CVC-1000, FFD, iLearn, In-Sight (design insignia with cross-hairs), In-Sight 2000, InspectEdge, Inspection Designer, MVS, NotchMax, OCRMax, PatMax RedLine, ProofRead, SmartSync, ProfilePlus, SmartDisplay, SmartSystem, SMD4, VisiFlex, Xpand

Portions copyright © Microsoft Corporation. All rights reserved.

Portions copyright © MadCap Software, Inc. All rights reserved.

Other product and company trademarks identified herein are the trademarks of their respective owners.

Table of Contents

Legal Notices	2
Table of Contents	3
Precautions	5
Symbols	6
Introduction	7
About the VisionPro 3D-L4000	7
Support	7
Accessories	7
Cables	7
Calibration Targets	8
Connectors and Indicators	9
Working Distances and Fields of View	11
Theory of Operation	12
Operation of the Triangulation Sensor	12
Raw 2D Images	12
Compensation of Perspective	14
Field Correction	15
Installation	20
Mount the 3D Sensor	20
Mount the 3D Sensor: Top Housing	21
Mount the 3D Sensor: Rear Housing	22
Mount the 3D Sensor: Through-Body	22
Connect the Ethernet Cable	23
Connect the Breakout Cable	24
Powering the 3D Sensor	24
Upgrading the 3D-L4000 Firmware from VisionPro 9.X to In-Sight Vision Suite	25
Cleaning and maintenance	28
Clean the Housing	28
Window Maintenance	28
Vision System Specifications	29
Dimensions	30
Laser Specifications	30
Ethernet Cable	31
Breakout Cable	32
Encoder Specifications	32
Encoder Inputs	33
Encoder Wiring	34
Trigger and Laser Enable Inputs	35
Trigger and Laser Enable Wiring	36
Outputs	36
Laser Models	37
Laser Compliance	37

Laser Safety Warnings	39
Label Locations	39
Regulations and Conformity	40
China RoHS	41
For European Community Users	42
Product Service	42

Precautions

To reduce the risk of injury or equipment damage, observe the following precautions when you install the Cognex product:

- The 3D sensor requires a UL or NRTL listed power supply with a 24VDC output that meets the following rating requirements:
 - At least 1A continuous current.
 - A maximum short circuit current of less than 4A.
 - A maximum power of less than 50VA and marked as a Limited Power Source (LPS) or National Electrical Code (NEC) Class 2.

Any other voltage creates a risk of fire or shock and can damage the components. Applicable national and local wiring standards and rules must be followed.

- This product is intended for industrial use in automated manufacturing or similar applications.
- The safety of any system incorporating this product is the responsibility of the assembler of the system.
- Do not install Cognex products where they are exposed to environmental hazards such as excessive heat, dust, moisture, humidity, impact, vibration, corrosive substances, flammable substances, or static electricity.
- Route cables and wires away from high-current wiring or high-voltage power sources to reduce the risk of damage or malfunction from the following causes: over-voltage, line noise, electrostatic discharge (ESD), power surges, or other irregularities in the power supply.
- This product does not contain user-serviceable parts. Do not make electrical or mechanical modifications to product components. Unauthorized modifications can void your warranty.
- Changes or modifications not expressly approved by the party responsible for regulatory compliance could void the user's authority to operate the equipment.
- Include service loops with cable connections.
- Ensure that the cable bend radius begins at least six inches from the connector. Cable shielding can be degraded or cables can be damaged or wear out faster if a service loop or bend radius is tighter than 10X the cable diameter.
- The 3D sensor M/S connectors are not supported.
- This device should be used in accordance with the instructions in this manual.
- All specifications are for reference purposes only and can change without notice.

Symbols

The following symbols indicate safety precautions and supplemental information:

 **WARNING:** This symbol indicates a hazard that could cause death, serious personal injury or electrical shock.

 **CAUTION:** This symbol indicates a hazard that could result in property damage.

 **Note:** This symbol indicates additional information about a subject.

 **Tip:** This symbol indicates suggestions and shortcuts that might not otherwise be apparent.

Introduction

Use the VisionPro 3D-L4000 sensor series for automated inspection, measurement, identification and robot guidance applications on the factory floor.

About the VisionPro 3D-L4000

A VisionPro 3D-L4000 offers high-performance 2K resolution and speckle-free BLUE and RED laser optics.

Support

Several resources are available to assist you in using the sensor:

- Your installed VisionPro documentation
- VisionPro online support site: <https://support.cognex.com/en/downloads/visionpro>



Accessories

You can purchase the following components separately. For a list of options and accessories, contact your local Cognex sales representative.

Cables



Note: Cables are sold separately.

CAUTION: All cable connectors are keyed to fit the connectors on the 3D sensor. Do not force the connections or damage may occur.

Accessory	Product Number	Illustration
X-Coded Ethernet Cable, straight, xx (xx specifies length: 2m, 5m, 10m, 30m)	CCB-84901-2001-xx (straight, xx specifies length: 2m, 5m, 10m, 15m, 30m)	
X-Coded Ethernet Cable, Straight, xx (xx specifies length: 2m, 5m, 10m)	CCB-84901-2002-xx (right-angled, xx specifies length: 2m, 5m, 10m)	
M12 with 17 pins to Flying lead, Straight, xx (xx specifies length: 2m, 5m, 10m, 20m)	CCB-PWIO17-S-xx (xx specifies length: 2m, 5m, 10m, 20m)	
M12 with 17 pins to Flying lead, Right Angle, xx (xx specifies length: 2m, 5m, 10m, 20m)	CCB-PWIO17-R-xx (xx specifies length: 2m, 5m, 10m, 20m)	

Calibration Targets

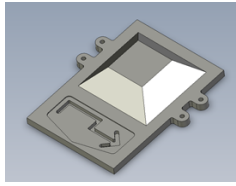
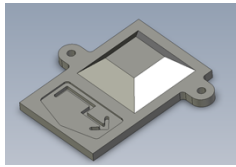
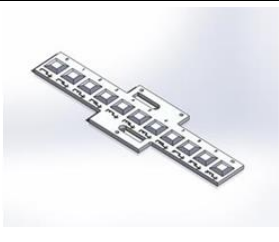



To perform a field calibration on a VisionPro 3D-L4000, you must use a Cognex-supplied calibration target. The target consists primarily of a frustum, a feature exhibiting six different planes with eight intersecting points.

Accessory	Correction Target	Illustration
40 mm 3D field calibration target	3DCAL40-2PK-00	
20 mm 3D field calibration target	3DCAL20-2PK-00	
10 mm 3D field calibration target	3DCAL10-KIT-00	
5 mm 3D field calibration target	3DCAL05-KIT-00	

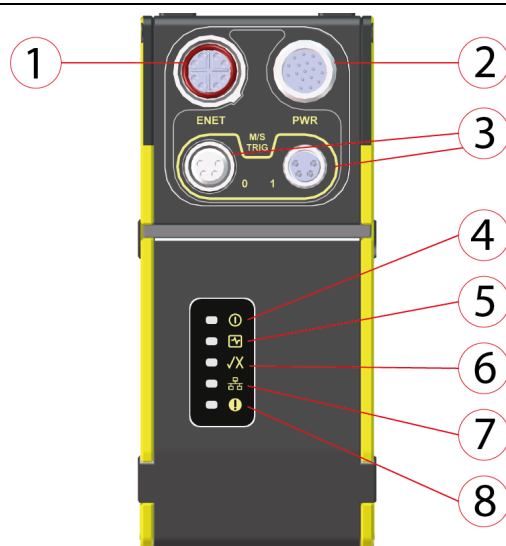
Contact your Cognex sales representative for choosing the right target for your application.

Connectors and Indicators



Number	Component	Description
1	ENET Connector	Connects the Ethernet cable, which provides 10/100/1000 Ethernet connectivity. For more information, refer to Ethernet Cable on page 31 .
2	PWR Connector	Connects the Breakout cable, which provides connections to an external power supply, the acquisition trigger input, and general-purpose inputs. For more information, see Breakout Cable on page 32 .
3	M/S TRIG Connectors	Not supported.
4		Power <ul style="list-style-type: none"> Hardware driven, this LED is always ON.
5		Laser Status <ul style="list-style-type: none"> ON: This LED is on when the 3D sensor performs acquisition, and stays on until the acquisition is complete and a final profile is acquired for a given image. OFF: No acquisition is in progress
6		Pass/Fail <ul style="list-style-type: none"> Reserved for In-Sight applications.
7		Ethernet status <ul style="list-style-type: none"> OFF: The 3D sensor does not detect Ethernet connection. ON: Ethernet connection was established. Blinking: Data transmission is in progress.

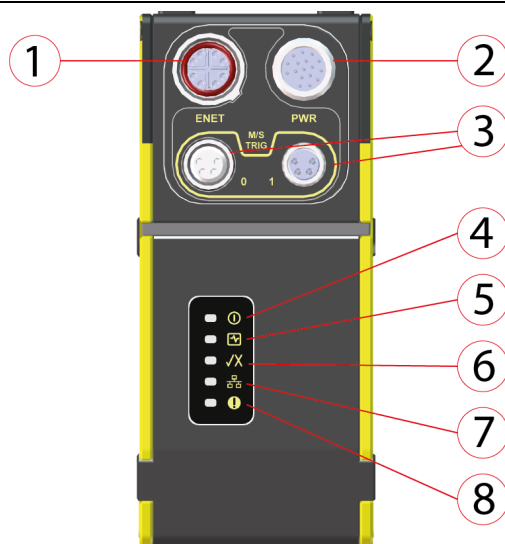

Number	Component	Description
8		<p>Status</p> <ul style="list-style-type: none"> • BLACK: GigE Vision firmware not loaded • YELLOW: GigE Vision firmware loading • GREEN: GigE Vision firmware loaded successfully • RED: GigE Vision firmware failure.

Working Distances and Fields of View

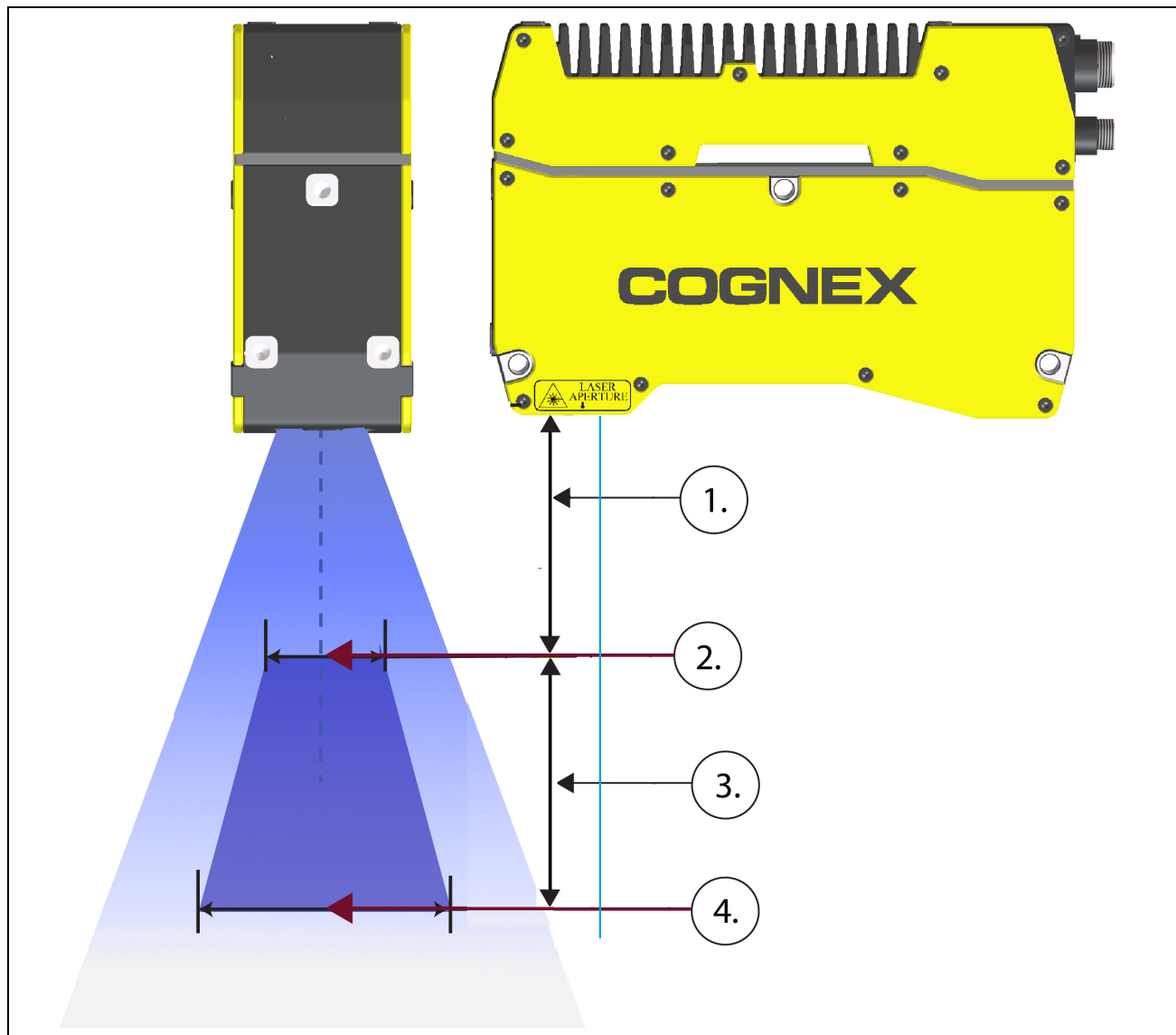

Number	Specification	3D-L4033	3D-L4050	3D-L4100	3D-L4300
1	Clearance Distance (mm)	93	92	130	180
2	Near Field of View (mm)	33	55	75	95
3	Measurement Range (mm)	44	106	235	745
4	Far Field of View (mm)	39	90	180	460

Theory of Operation

This section gives a brief overview about the theory of operation.

Operation of the Triangulation Sensor

A triangulation sensor measures objects by imaging the intersection of a uniform planar light source and an object. The sensor projects a sheet of light through a measurement area. The 3D sensor captures this area at an angle, out of the plane of the sheet. When an object passes through the sheet, a laser stripe appears on the object's visible surface, which is imaged onto the detector. The software reduces the image data to a representative profile. Profiles are combined into a range image which contains 3D information (height, volume, etc).

The properties of the major elements of the system determines the sensitivity and accuracy of the measurement. The light source is a laser with a large divergence in one axis (20 - 40 degrees) and minimal divergence and extent in the perpendicular axis. Since the object plane is angled relative to the camera, you have to position the camera sensor to achieve optimal focus across the field.

When the 3D sensor reads the image from the system, the image is then processed to

- Detect the line and determine its location
- Calibrate the line's position
- Assemble the calibrated profile data

Note: There are certain image distortions that derive from the fact that the 3D sensor has a fixed-point aspect, has a lens, and the object is moving under the unit. However, VisionPro uses the calibrated profile data from the 3D sensor (factory calibrated in manufacturing). As a result, the range image does not show unwanted optical effects.

Raw 2D Images

The following overview illustrates how the 3D sensor captures the raw 2D images, which is the first step in acquiring a range image.

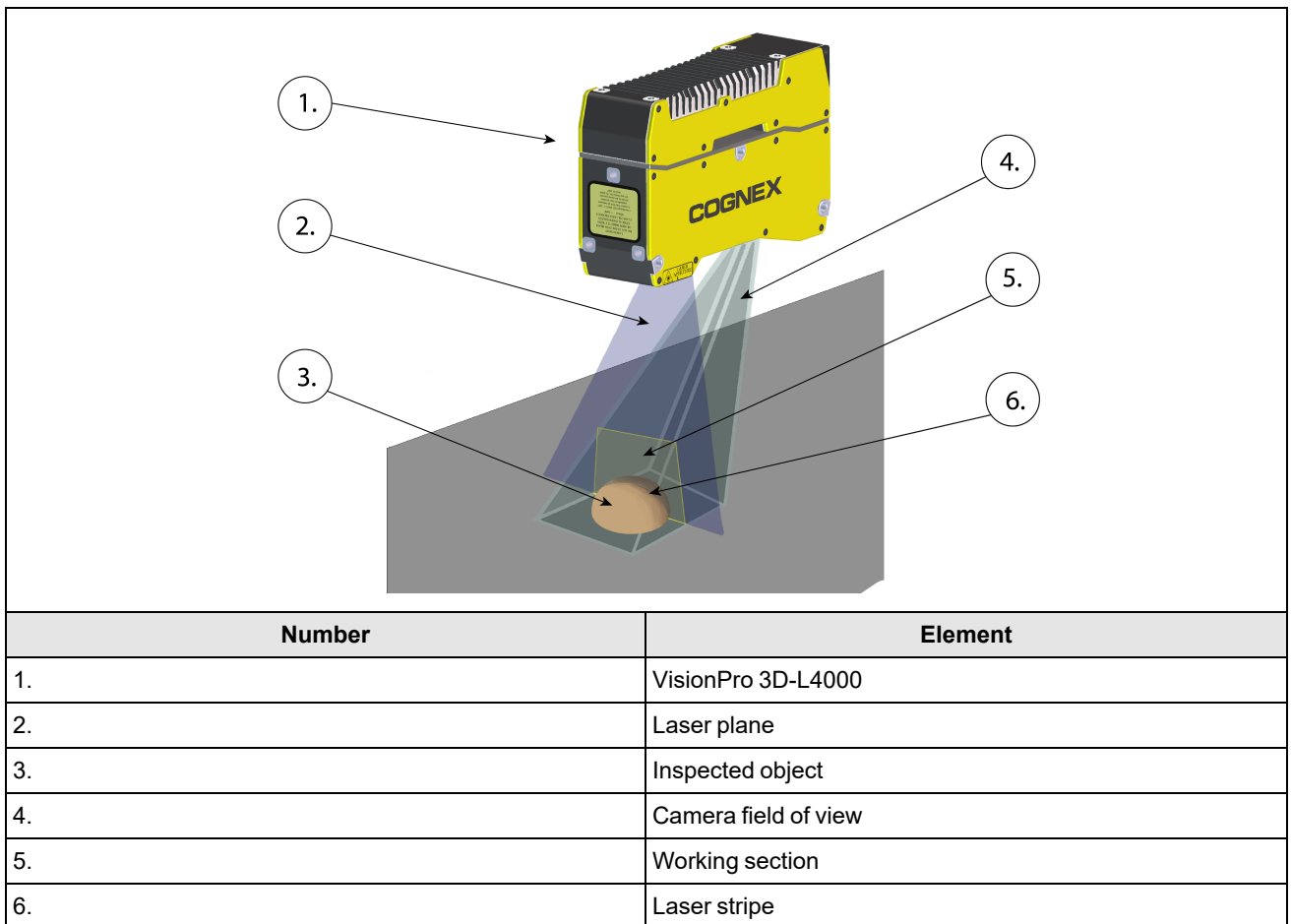

The 3D sensor (1) projects a triangular laser plane (2) onto the object under inspection (3), illuminating the object's surface. The illumination of the laser plane determines the peak data of the raw 2D image and results in the 3D-L4000's laser stripe (6) within its field of view (4). The surface of the object determines the shape of the laser stripe, which provides the exact height profile information of the object; see the illustration below.

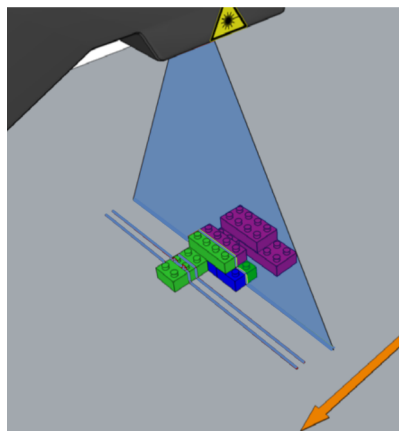

The following image illustrates the laser stripe as seen from the position of the 3D sensor (on the left). The raw 2D image is what the 3D sensor sees (on the right).

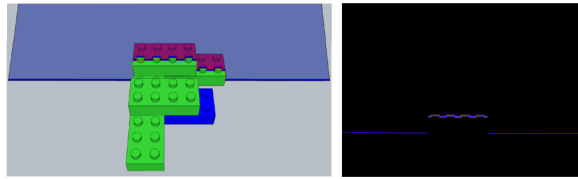

The 3D sensor then applies an algorithm to find the peaks to extract the uncalibrated peak data. On the image below, the CYAN BLUE lines represent a subregion of the field of view working section (see [Working Distances and Fields of View on page 11](#)), where the 3D sensor is looking for peak data. The PURPLE stripe at the lower section of the image is created by the software and marks the peak of the uncalibrated data.

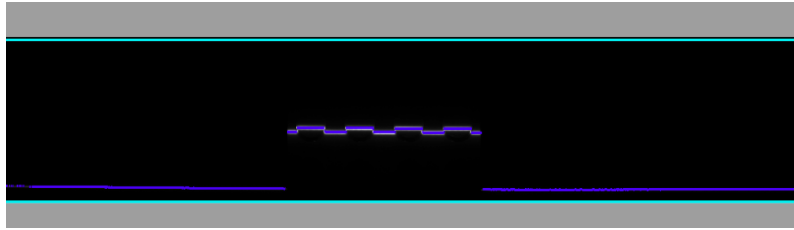

Compensation of Perspective

Due to its position, a laser stripe that is closer to the 3D sensor appears closer and wider in the raw profile image. This introduces perspective: a distortion in the uncalibrated peak data.

The following image illustrates the effect of perspective distortion with two laser stripes of the same width.

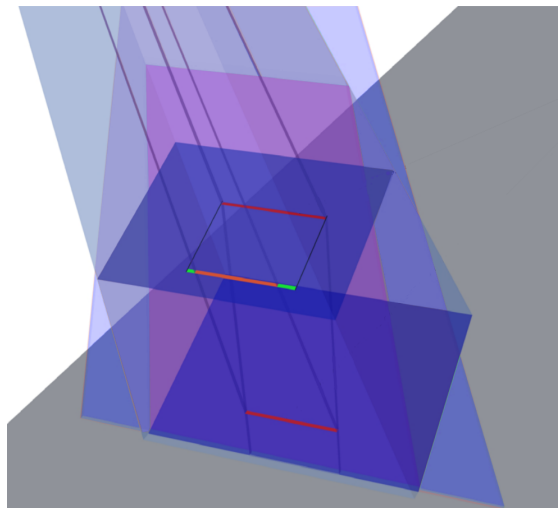

Although the two RED stripes have the same width, the lower one seems narrower.

The ORANGE stripe shows the width of the lower RED stripe, relative to the upper RED stripe. The GREEN portions show the difference between the two widths.

Consider a Lego® block scanned by the 3D sensor. As it passes under the camera, the laser stripe appears for each step.

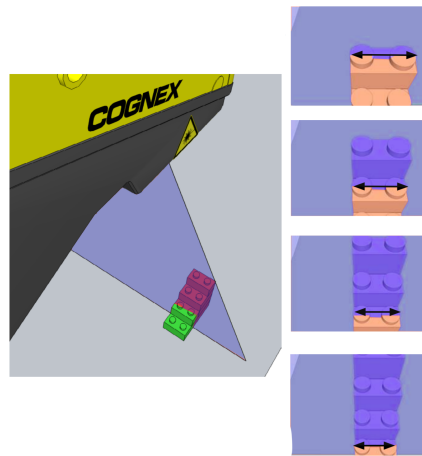

If the 3D sensor produced an uncalibrated image, the image would look like the colorized image below.



Factory calibration converts the distorted image into the calibrated image. The calibrated image then allows the calculation of parameters like the exact volume of the object. The image below shows the top view (left) and the perspective view (right).

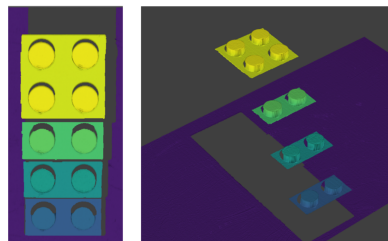

Field Correction

When the 3D-L4000 is mounted on a frame, the vision system and the motion stage is not 100% aligned:

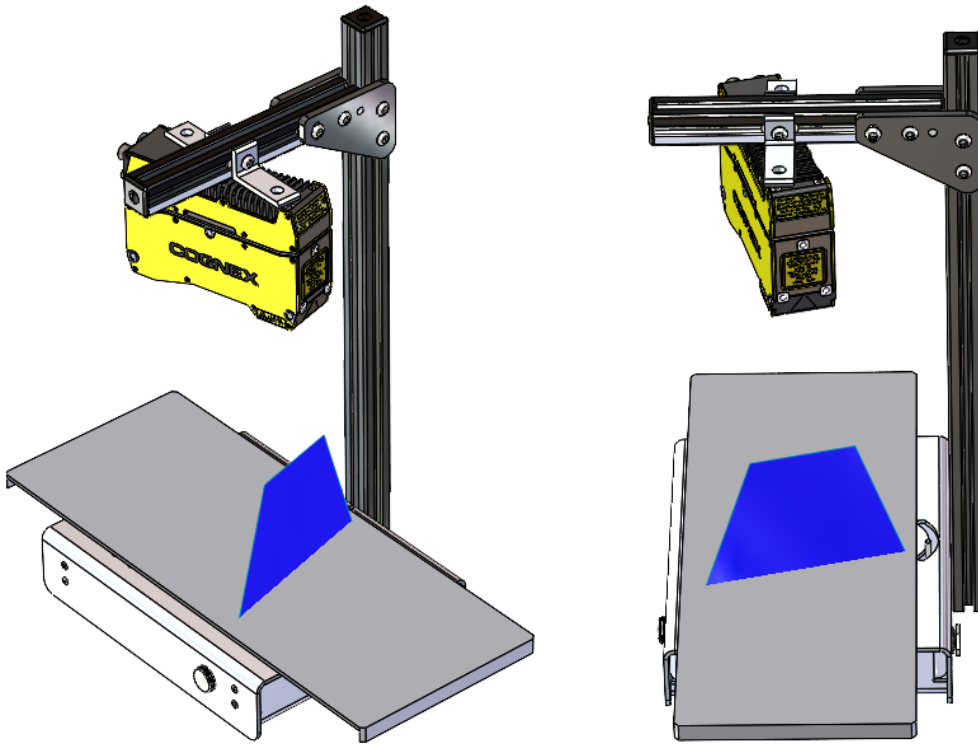

In order to generate an accurate 3D image of a scene, you have to correct the relative motion between a vision system and a motion stage in terms of Motion Direction and Motion Speed (or Encoder Resolution in case of encoder acquisition). If you do not correct Motion Direction, the scanned image can be skewed or distorted. If you do not correct Motion Speed, the scanned image can be elongated or squeezed.

The following images are without field correction:

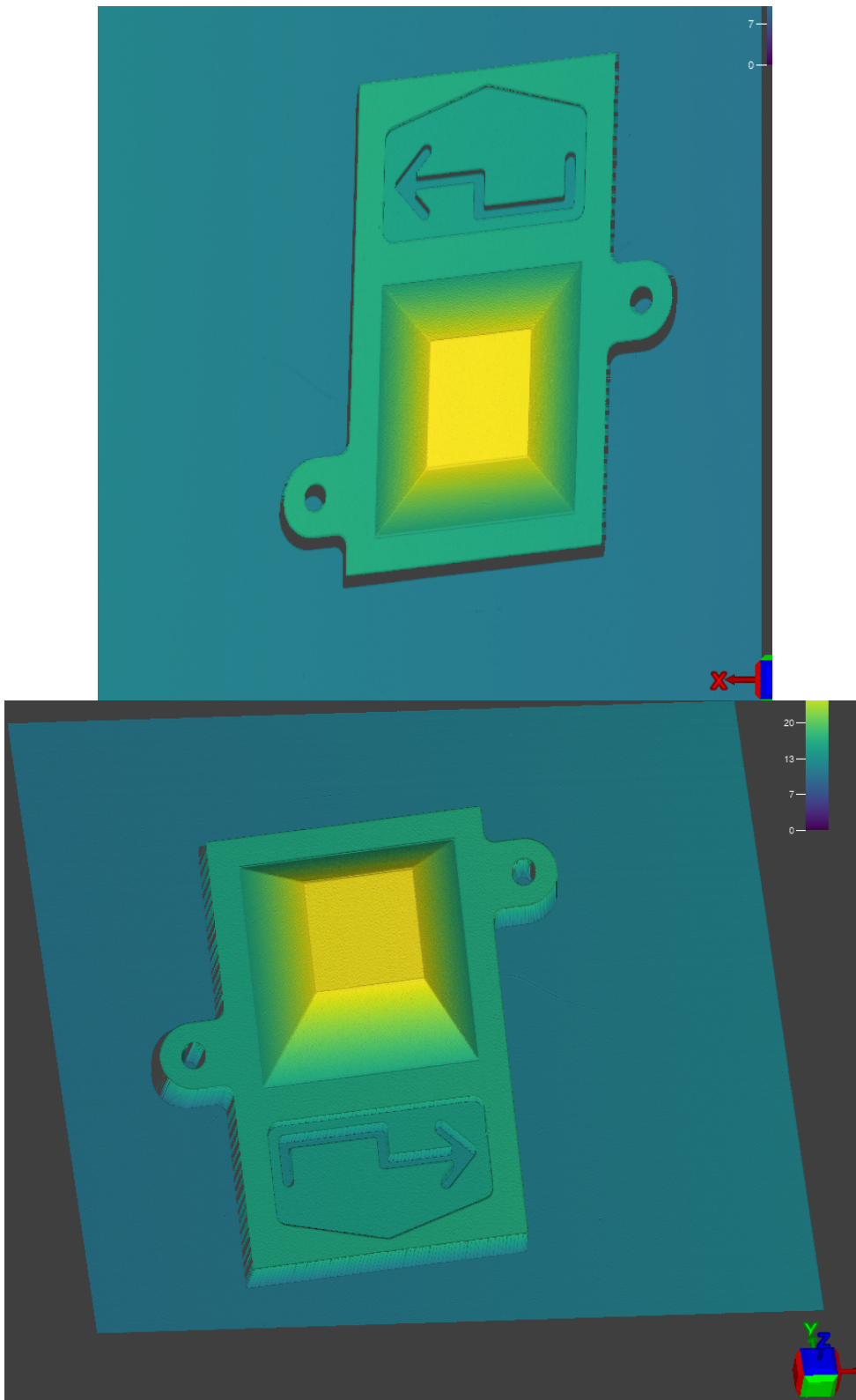

The following images are corrected with field correction:

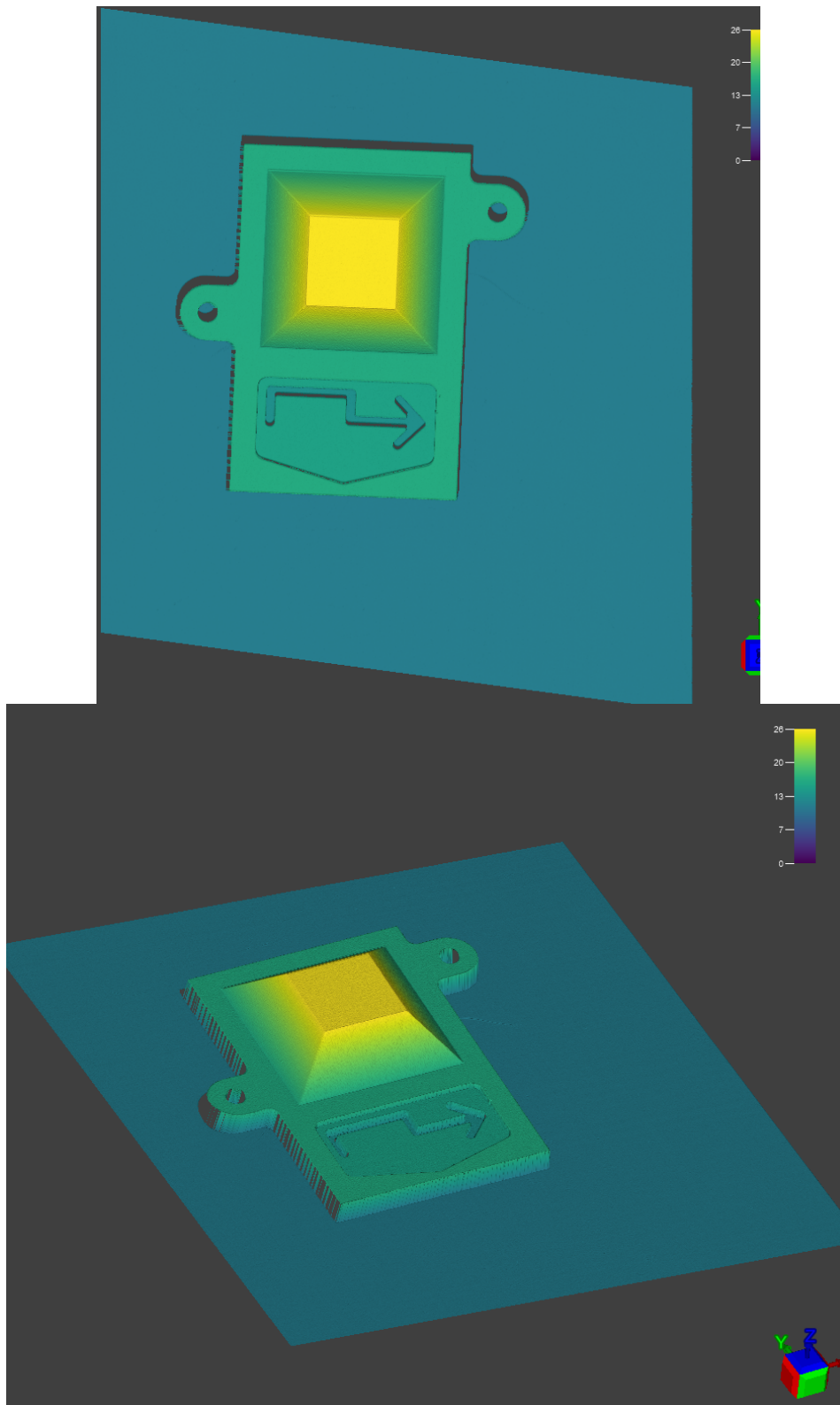

For more information about field correction settings, see the *3DL400 Series Vision System Wizard - Correction Settings* section in the *VisionPro 3D Software Help* document.

The 3D-L4000 can correct the following degrees of misalignment:

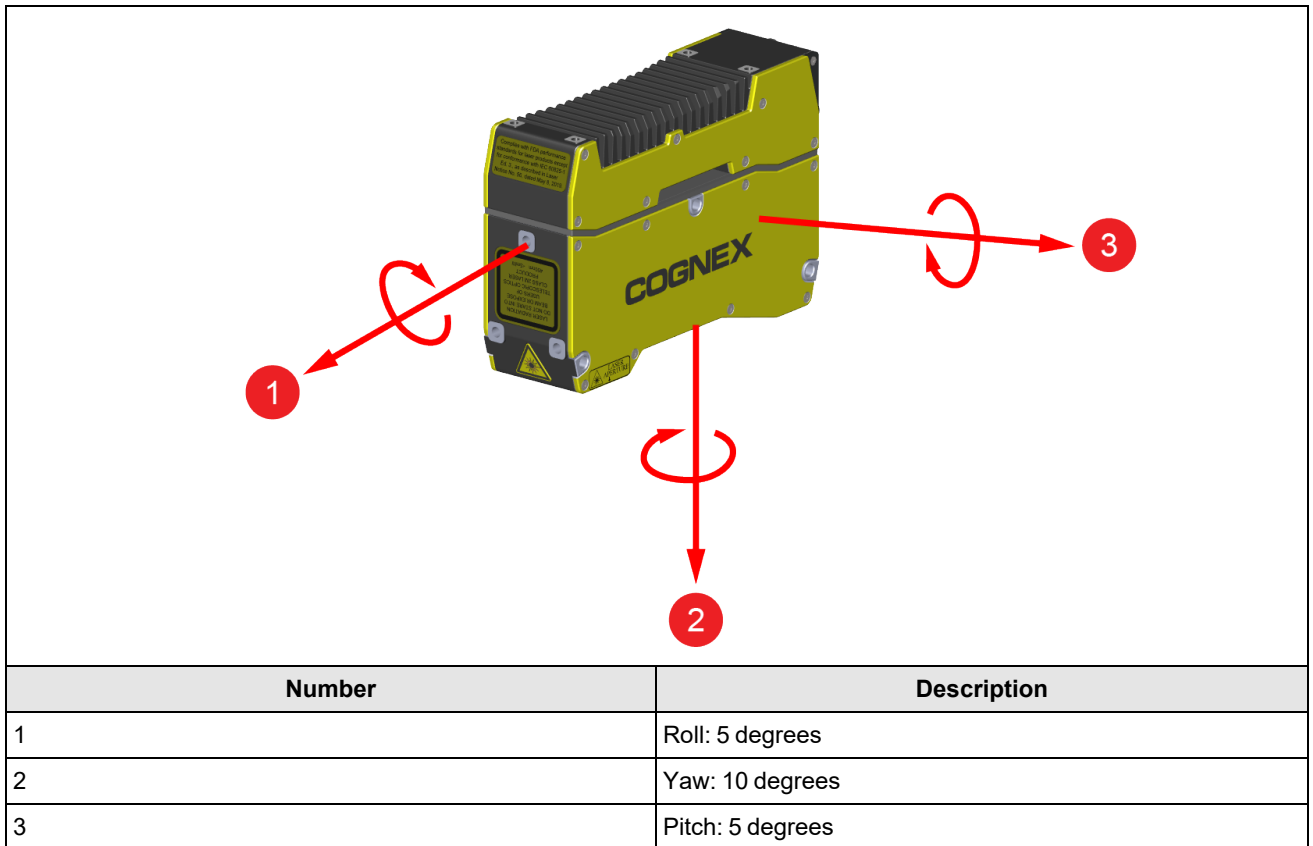

Installation

Read this section to learn how the 3D sensor connects to standard components and accessories. For a list of options and accessories, contact your Cognex sales representative.

Note: Cables are sold separately.

CAUTION: All cable connectors are keyed to fit the connectors on the 3D sensor. Do not force the connections or damage may occur.

See the list of [Cables on page 7](#).

Mount the 3D Sensor

In order to operate the 3D sensor accurately, make sure to mount the VisionPro 3D-L4000 firmly and perpendicular to the motion of travel. This way, the acquired range images will be repeatable and accurate.

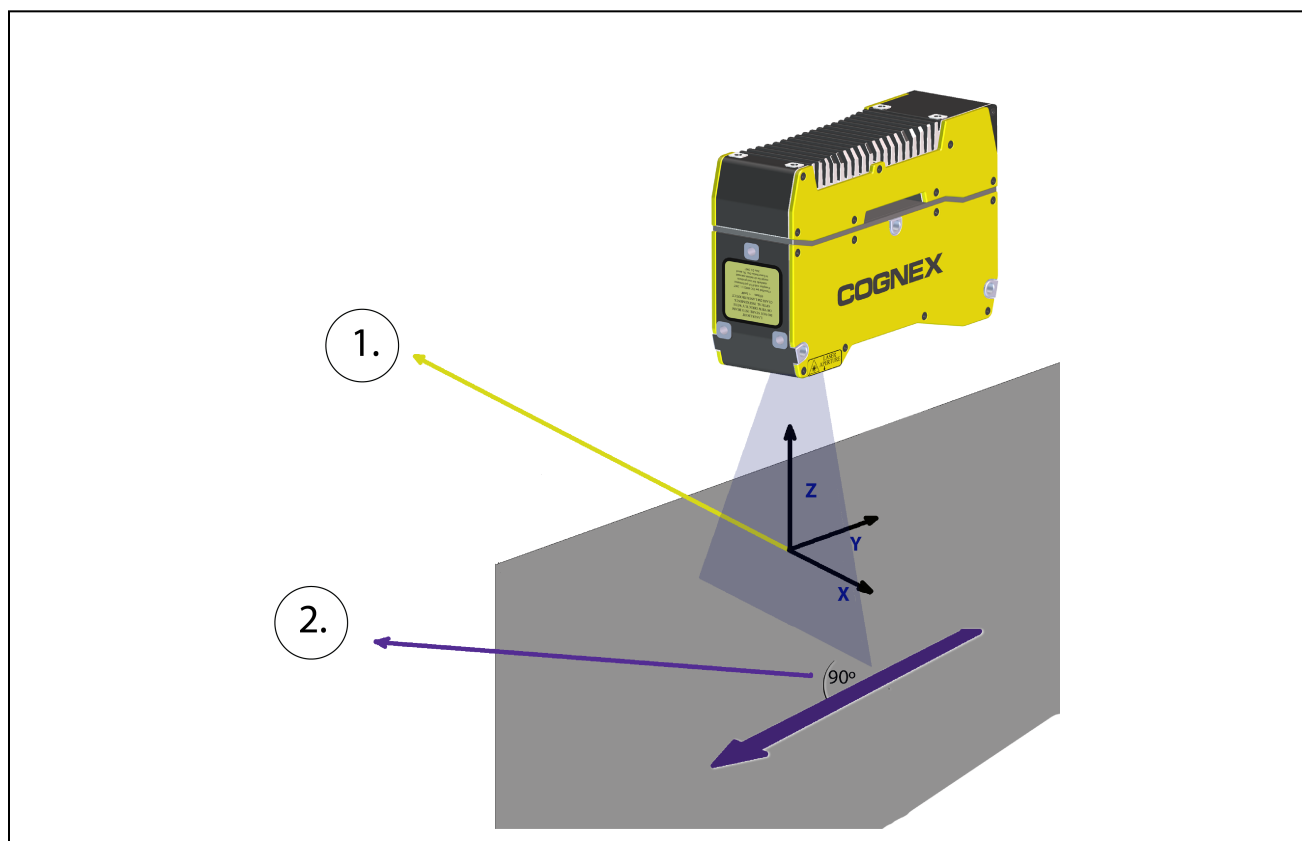

Number	Guideline
1.	The origin of the X-axis is the optical centerline of the sensor projected onto the Working Section.
2.	Arrange the 3D sensor in a way so that the motion of travel is perpendicular to the laser plane.

Note: The 3D sensor can shut down above maximum operating temperature. To avoid overheating you can heatsink the 3D sensor by attaching a 400 mm aluminum profile or surface of a thermally conductive material (for example robot mounting plate) on top of the unit.

Mount the 3D Sensor: Top Housing

1. Align the holes on the mounting surface with the mounting holes on the 3D sensor.
2. Insert the M4 screws into the top mounting holes and tighten. The maximum torque is 2.00Nm (17.70in-lb). Do not exceed the maximum insertion depth of 8 mm for the M4 screws. The maximum insertion depth does not include the thickness of the mounting material.



Mount the 3D Sensor: Rear Housing

1. Align the holes on the mounting surface with the mounting holes on the 3D sensor.
2. Insert the M5 screws into the rear mounting holes and tighten. The maximum torque is 3.00 Nm (26.55 in-lb). Do not exceed the maximum insertion depth of 8 mm for the M5 screws.. The maximum insertion depth does not include the thickness of the mounting material.

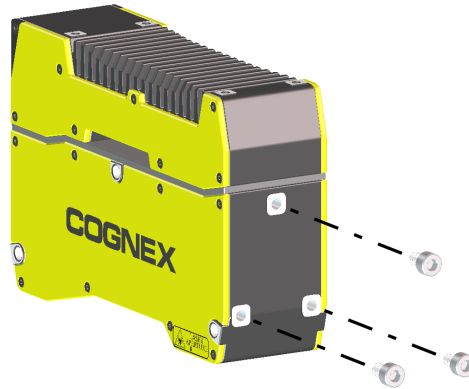

Mount the 3D Sensor: Through-Body

1. Insert M4 screws (or appropriate hardware) through the 5mm holes on the 3D sensor.
2. Attach the screws to a mount to prevent the sensor from shifting during operation. The maximum torque is 2.00Nm (17.70in-lb).



Connect the Ethernet Cable

CAUTION: The Ethernet cable shield must be grounded at the far end. Whatever this cable is plugged into (typically a switch or router) should have a grounded Ethernet connector. A digital voltmeter should be used to validate the grounding. If the far end device is not grounded, a ground wire should be added in compliance with local electrical codes.



1. Connect the Ethernet cable's M12 connector to the 3D sensor ENET connector.
2. Connect the Ethernet cable's RJ-45 connector to a switch, router or PC, as applicable.

Connect the Breakout Cable

For more information, see [Breakout Cable on page 32](#)

⚠ CAUTION: To reduce emissions, connect the far end of the Breakout cable shield to frame ground using the exposed drain wire.

Note:



- Perform wiring or adjustments to I/O devices when the 3D sensor is not receiving power.
- You can cut exposed wires short or trim wire ends. You also can tie the wires back if you use a tie made of non-conductive material. Keep bare wires separated from the +24VDC wire.

1. Verify that the 24 VDC power supply is unplugged and not receiving power.
2. To make sure the laser functions correctly, make sure that the LASER ENABLE (WHITE/Violet wire) and IN COMMON (GREEN wire) are connected.
 - For NPN lines, connect LASER ENABLE to ground and connect IN COMMON to +24 VDC.
 - For PNP configurations, connect LASER ENABLE to +24 VDC and connect IN COMMON to ground.



Note: The IN COMMON signal is shared with the TRIGGER and LASER ENABLE inputs. Therefore, the operating mode (NPN or PNP) must be identical for both ports. The voltage difference between the TRIGGER or LASER ENABLE inputs and IN COMMON needs to be at least 10 V to turn the input on and less than 3 V to turn the input off.



CAUTION: If LASER ENABLE is not wired properly, the laser will not turn on after triggering the 3D sensor.

3. Optionally, connect the I/O wires to an appropriate device.
4. The PHA+ (BROWN wire) and PHA- (WHITE/BROWN wire) and PHB+ (YELLOW wire), PHB- (WHITE/YELLOW wire) are used for an encoder connection.

Note:



- The encoder signals are referenced to the same GND as the 24 VDC power. If the encoder uses a different power supply from the 24 VDC supply, the encoder supply and the 24 VDC supply need to have a common GND connection.
- Cognex recommends to ground unused encoder connections. If you configure the 3D software to use an encoder but do not connect the encoder signal inputs, the behavior of the encoder counter is undetermined.

5. Attach the Breakout cable's +24 VDC (Red wire) and GND (BLACK wire) to the corresponding terminals on the power supply.



CAUTION: Never connect voltages other than 24 VDC. Always observe the polarity shown.

6. Connect the Breakout cable's M12 connector to the 3D sensor PWR connector.
7. Restore power to the 24VDC power supply and turn it on if necessary.

Powering the 3D Sensor

The 3D-L4000 has no dedicated power switch. The 3D sensor powers on when you connect a power supply through a breakout cable.

When the 3D sensor is on, the Power LED on top of the unit will turn GREEN.



Upgrading the 3D-L4000 Firmware from VisionPro 9.X to In-Sight Vision Suite

Note:



- If your camera is a PC-based 3D-L4000 (product ID: 3DL4XXX-000-N), your camera requires a Field Service Update (product ID: FSU-L4000-20-3760) to be able to use it as an In-Sight vision system.
- You have to have an In-Sight 1.2.0 or newer installed at least to perform the firmware update.

1. Start the Cognex GigE Vision Configurator, available with your install of VisionPro 9.
2. Find the IP address of the 3D-L4000 by using the network connections tree.

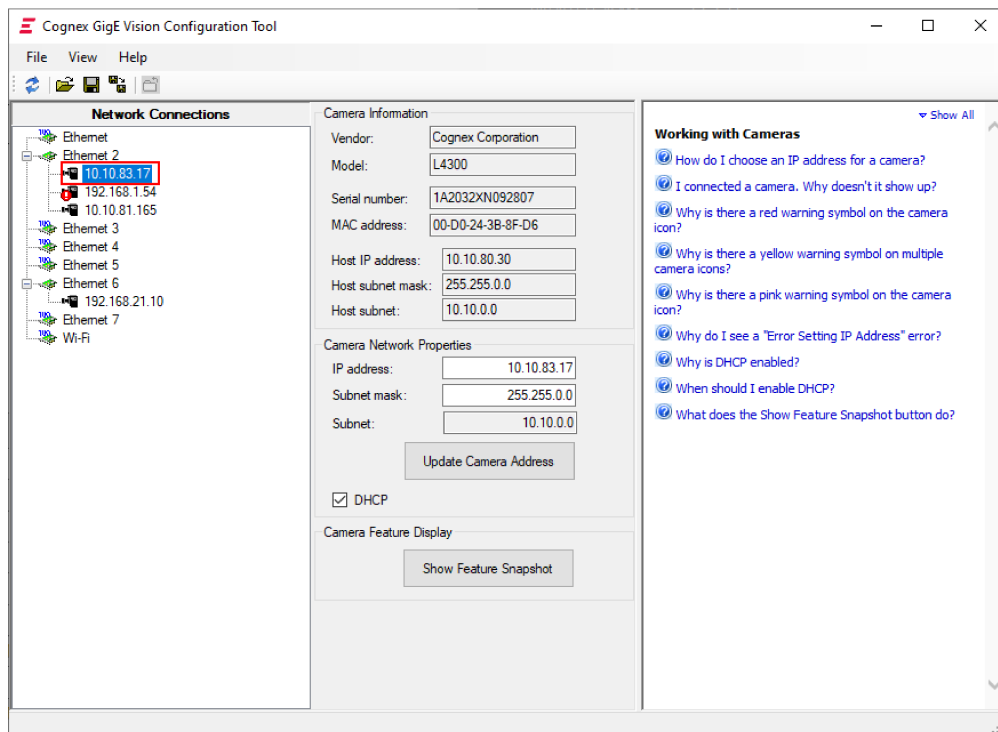

- Open a web browser and type the IP address of the 3D-L4000 into the URL to open the Firmware update page.

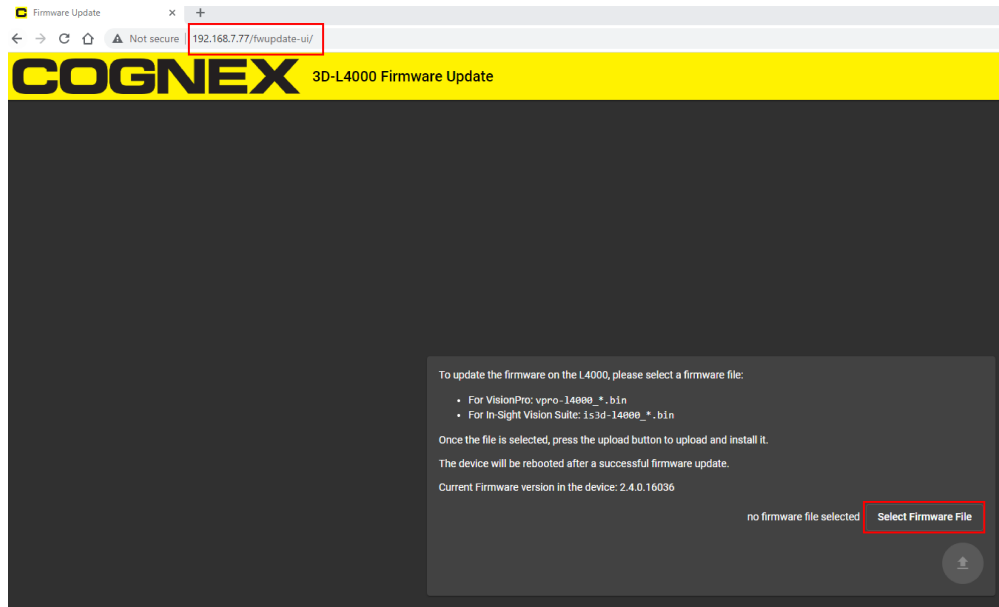

- Click on the **Select Firmware File** button.
- On the pop-up window, go to *C:\Program Data\Cognex\Firmware\In-Sight 3D\<version>*, then select the *s3d-l4000.bin* file and click on the **Open** button.

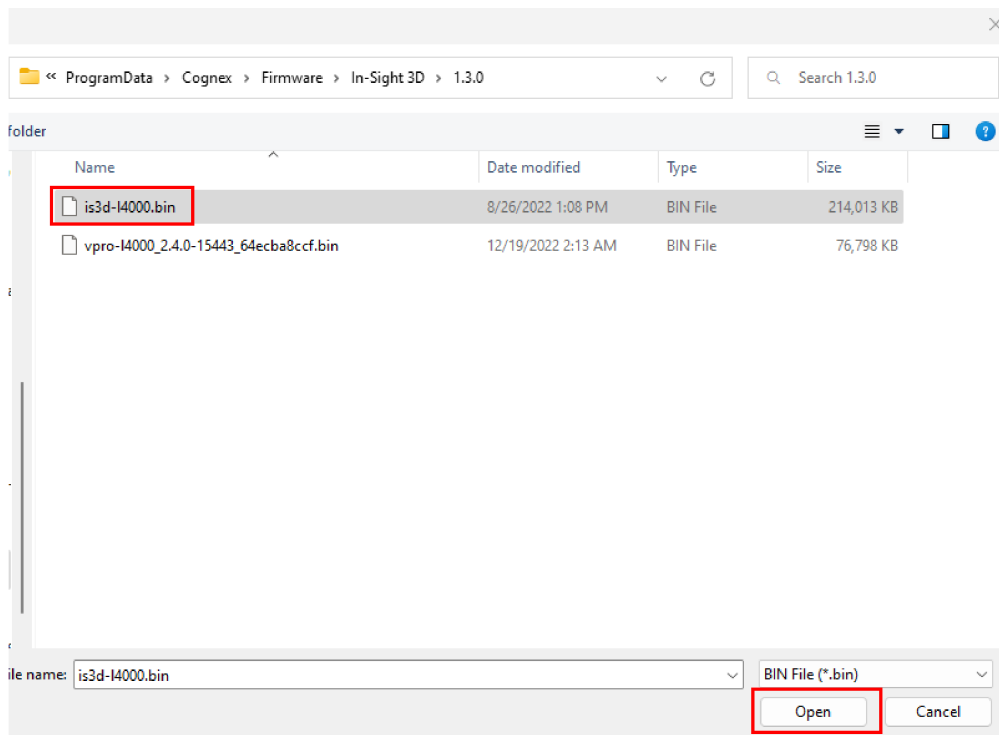

6. Click on the **Upload** button to upload the firmware file.

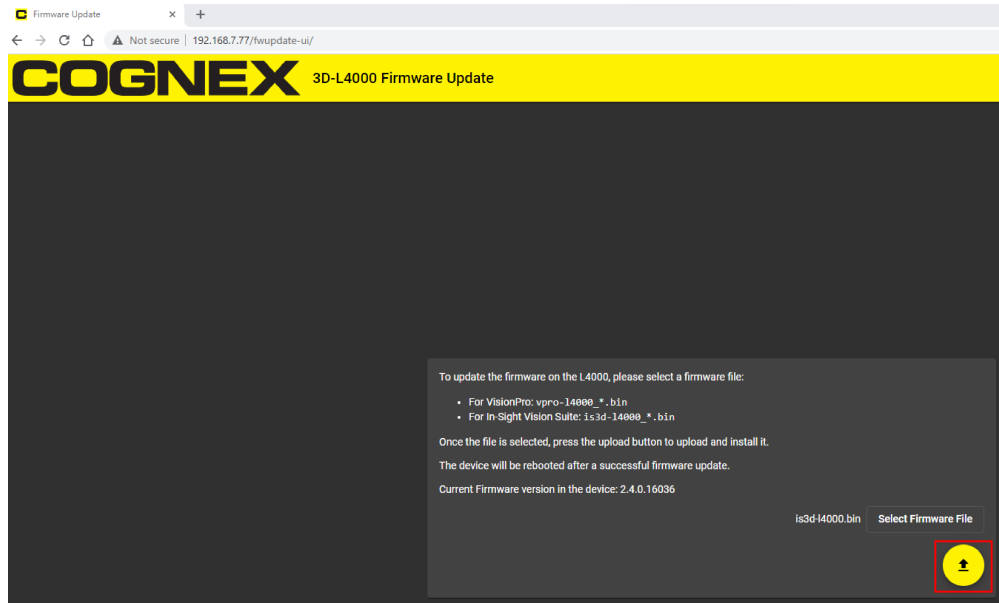

7. When the firmware upload finishes, close the web browser and open the In-Sight Vision Suite 1.2.0 or newer to discover the camera.

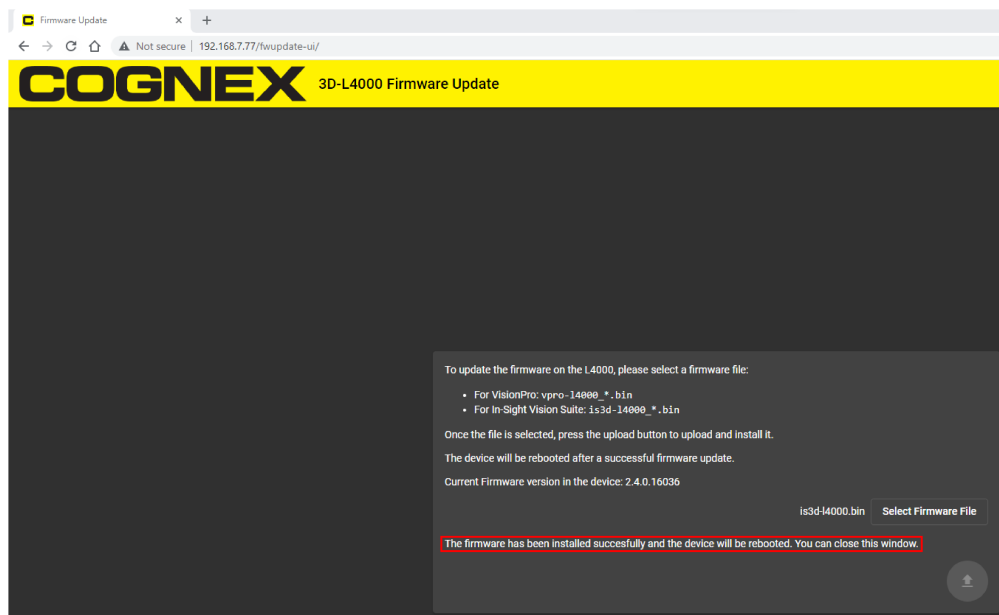

Cleaning and maintenance

This chapter gives an overview about the cleaning and maintenance of the 3D sensor.

Clean the Housing

To clean the outside of the 3D sensor housing, use a small amount of mild detergent cleaner or isopropyl alcohol on a cleaning cloth. Do not pour the cleaner on the 3D sensor housing.

 **CAUTION:** Do not attempt to clean any VisionPro product with harsh or corrosive solvents, including lye, methyl ethyl ketone (MEK) or gasoline.

Window Maintenance

The windows of the 3D sensor and laser must be kept clean and free of defects to ensure proper operation. Any scratches, dust or dirt will impact the accuracy of acquired images.

 **CAUTION:** Use care not to damage the anti-reflective coating on the windows.

Cognex makes the following recommendations for cleaning the laser and 3D sensor windows:

- Unplug the unit so the laser cannot be enabled.
- Use lint-free tissue or an optical grade cotton swab ("Q-tip").
- Use reagent-grade isopropyl alcohol.
- Use minimal pressure.
- Use several tissues or swabs.
- Start at the center of each window and spiral out to the edges.
- Rotate the tissue or swab during cleaning so dirt is not dragged across the surface.

Vision System Specifications

Specification	3D-L4033	3D-L4050	3D-L4100	3D-L4300
Scan rate	Up to 4 kHz			
Resolution X-axis	1920 points/profile			
Built-in I/O	Inputs: 1 dedicated trigger, 1 laser safety Outputs: 2 user-definable			
Encoder Input Specification	Differential: A+/B+/A-/B-: 5-24 V (1000 kHz max) Single Ended: A+/B+: 12-24 V (1000 kHz max) A-/B-: $V_{\text{encoder}}/2$ (6-12 V DC)			
Network Communication	<ul style="list-style-type: none"> Gigabit Ethernet interface Integrated link and traffic LED Standard M12-8 X-Coded female connector 			
Dimensions	150.5 mm x 101 mm x 45 mm			
Weight	0.94 kg			
Operating Temperature	0°C to 35°C (32°F to 95°F) without heat sink 35°C to 45°C (95°F to 113°F) with heat sink			
Storage Temperature	-20°C to 70°C (-4°F to 158°F)			
Operating and Storage Humidity	<80%, non-condensing			
Protection	IP65 with all cables properly attached and M/S TRIG connectors capped.			
Shock (Shipping and Storage)	15 G's, 6 milliseconds half sinusoidal			
Vibration (Shipping and Storage)	10 to 57 Hz, double amplitude 1.5 mm X,Y,Z, 3 hours in each direction			
Certification	CE, FCC, KCC, TÜV SÜD NRTL, RoHS			

Dimensions

Note:



- All Dimensions are in millimeters [inches] and are for reference purposes only.
- All specifications are for reference purposes only and can change without notice.

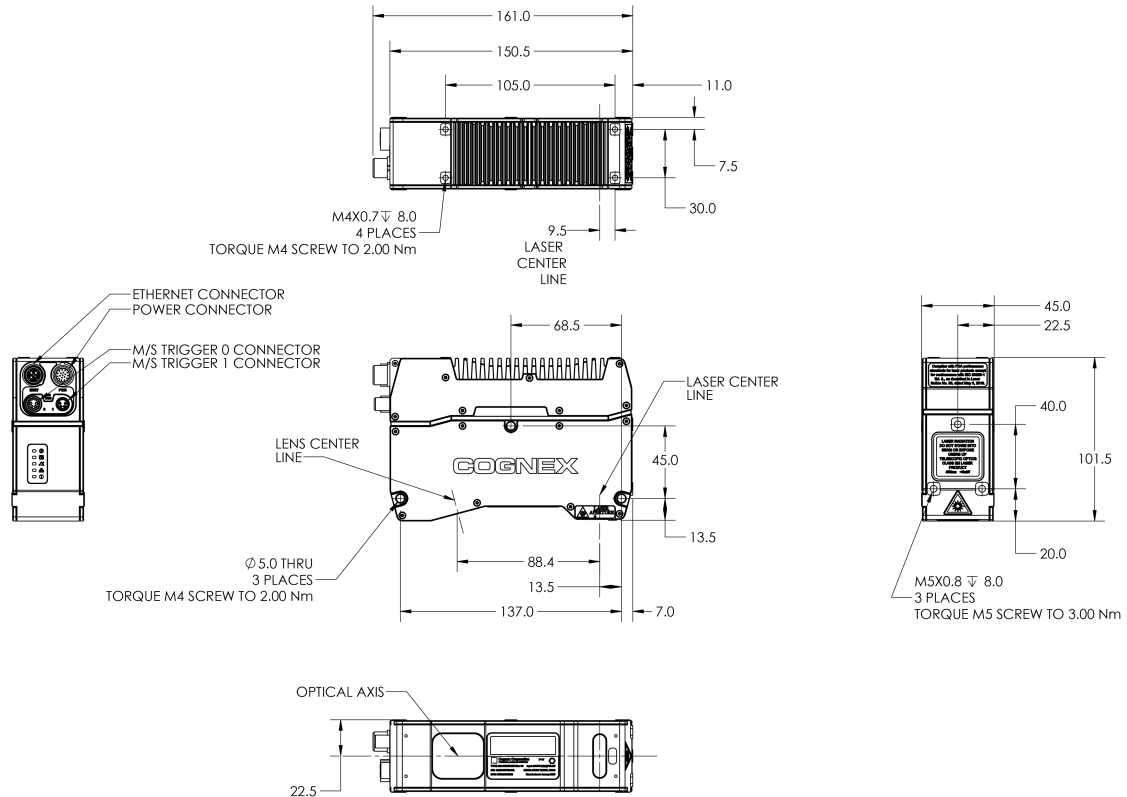

Laser Specifications

This laser product has a Class 2M designation.

The table below summarizes environmental and power supply specifications for 3D-L4000 series sensors:

Blue Laser (light source)	Value
Wavelength	450 nm
Laser class	2M
Output power	4.7 mW

Red Laser (light source)	Value
Wavelength	640 nm
Laser class	2M
Output power	4.4 mW

Ethernet Cable

The Ethernet cable provides Ethernet connectivity to the 3D sensor.

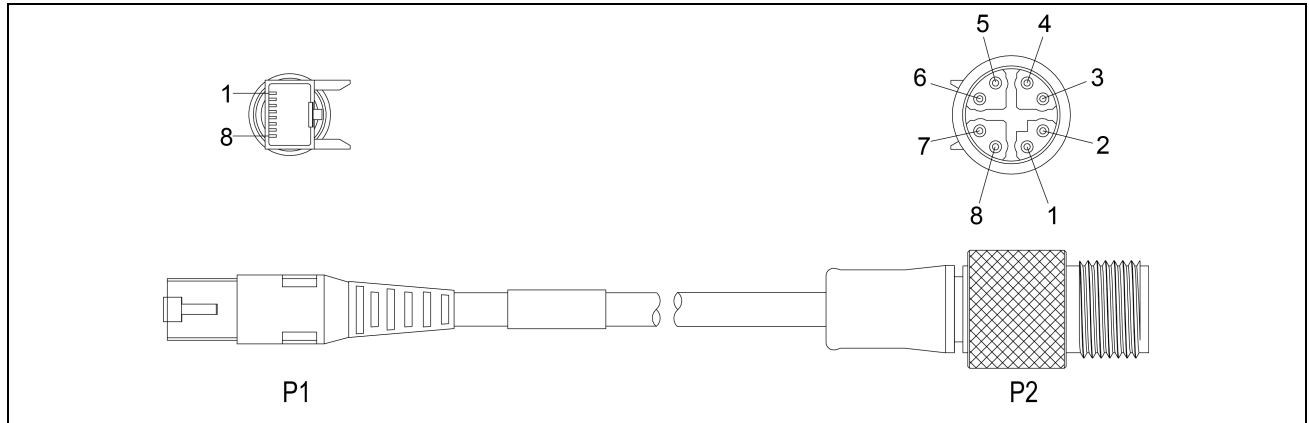

P1 Pin Number	Wire Color	Signal Name	P2 Pin Number
1	WHITE/ORANGE	TxRx A +	1
2	ORANGE	TxRx A -	2
3	WHITE/GREEN	TxRx B +	3
4	BLUE	TxRx C +	8
5	WHITE/BLUE	TxRx C -	7
6	GREEN	TxRx B -	4
7	WHITE/BROWN	TxRx D +	5
8	BROWN	TxRx D -	6

CAUTION: The Ethernet cable shield must be grounded at the far end. Whatever this cable is plugged into (typically a switch or router) should have a grounded Ethernet connector. A digital voltmeter should be used to validate the grounding. If the far end device is not grounded, a ground wire should be added in compliance with local electrical codes.

Note:

- Cables are sold separately.
- The wiring for this cable follows standard industrial Ethernet M12 specifications. It differs from the 568B standard.

Breakout Cable

The Breakout cable provides access to trigger and inputs. You can clip unused wires short or use a tie made of non-conductive material to tie them back.

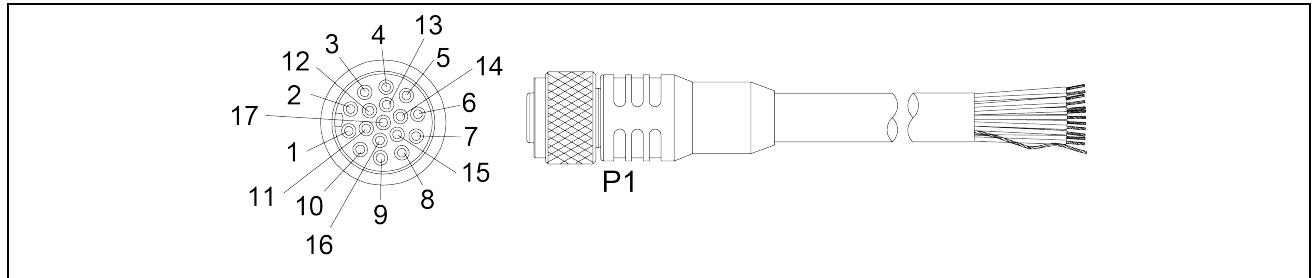

Pin #	Signals Name	Color
1	PHB+	YELLOW
2	PHB-	WHITE/YELLOW
3	PHA+	BROWN
4	PHA-	WHITE/BROWN
5	TRIGGER	Violet
6	LASER ENABLE	WHITE/Violet
7	+24VDC	Red
8	GND	BLACK
9	IN COMMON	GREEN
10	Unused	ORANGE
11	Unused	BLUE
12	Reserved	Grey
13	Reserved	WHITE/GREEN
14	Reserved	WHITE/ORANGE
15	Reserved	WHITE/BLUE
16	Reserved	WHITE/Grey
17	Reserved	WHITE/Red
SHELL	SHIELD	Braided Wire

Encoder Specifications

The 3D sensor typically relies on electrical signals from an encoder to generate images, allowing the 3D sensor to capture image information based on the speed of the moving object rather than predetermined acquisition timing. Many vision applications use a rotary encoder attached to the conveyor system.

Note:



- The frequency of 1x encoder pulses must not exceed 1000 kHz.
- Using an encoder allows you to specify input and output delay values in pulse counts instead of real time units.

A quadrature rotary encoder uses two output channels (A and B) to provide cyclical outputs as the encoder rotates. The signals are *quadrature* outputs - 90 degrees out of phase with each other. Each complete quadrature cycle consists of four rising or falling *pulse* edges. The number of cycles per encoder rotation depends on the specific encoder you use.

Note: A single-channel encoder only uses the A channel.

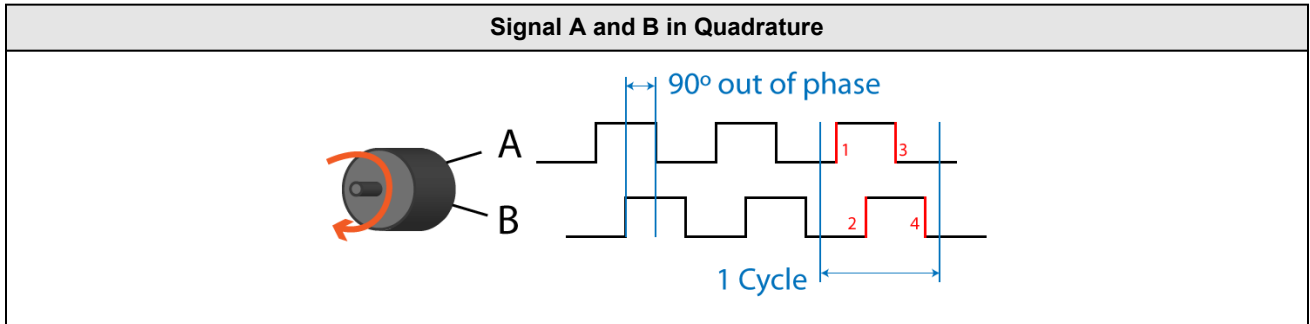

The distance per cycle is the physical distance that the conveyor system needs to travel to cause the encoder to output one full cycle. This distance can be calculated based on the dimensions of your encoder and the length of the image you want to acquire.

The 3D sensor supports single-channel and quadrature encoders.

- Single-channel encoders generate only one signal (A). Be aware that single-channel encoders cannot determine which direction the conveyer system is moving.
 - Software features that manage encoder resolution do not apply to single-channel encoding.
 - A DS1000 sensor increments the encoder count by one for each complete encoder cycle.
 - A 3D-L4000 sensor increments the encoder count by two for each complete encoder cycle.
- Quadrature encoders use two channels (A and B) to specify the direction of motion. 3D-L4000 uses the following convention for determining the direction of motion:
 - Positive: PHA leads PHB
 - Negative: PHA lags PHB

Encoder Inputs

The following image shows the Encoder Phase A and B Inputs (5 V - 24 V, Differential or 12-24 V Non-Differential). For a single-ended encoder, connect PHA+ and PHB+ to the encoder outputs. Derive PHA- and PHB- from the encoder voltage source and make them equal to 50% of the encoder reference voltage. For example, if the encoder is connected to 24 V, set PHA- and PHB- to 12 V.

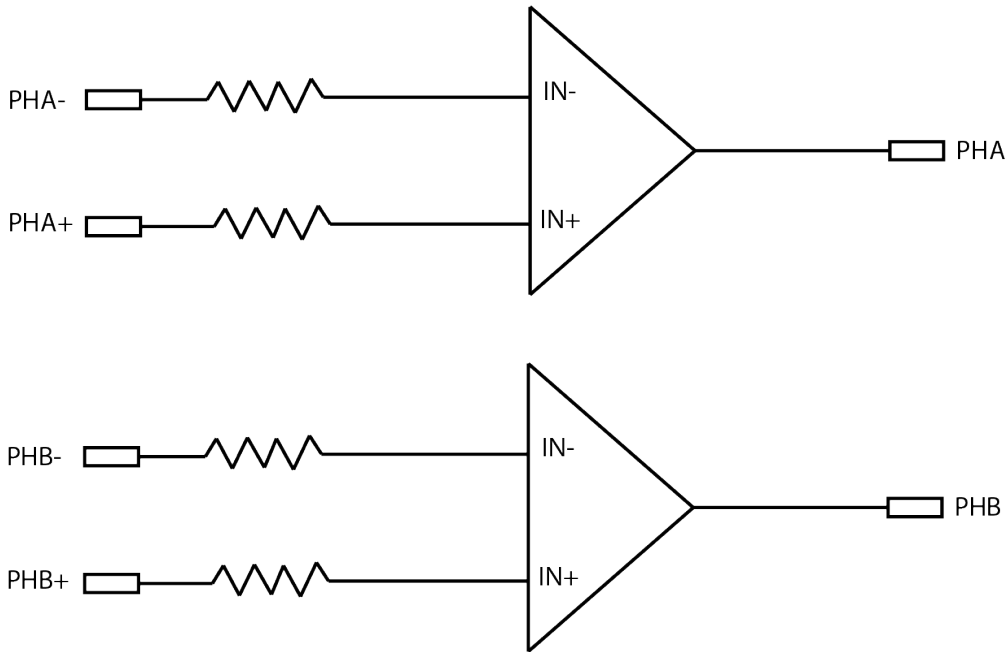

Note: If you are using a Single-Channel Encoder, always connect to the 'PHA' input.

WARNING: The frequency of pulses has to remain under 1000 kHz.

- Single-ended encoders use one wire each for signals A and B. Be aware single-ended encoders are susceptible to electrical noise. When using a single ended encoder, set the complementary differential inputs, A- and B-, to 1/2 of the encoder operating voltage (e.g. 12 V for a 24 V encoder.) Use only 12 V or 24 V single ended encoders.
- Differential encoders use two lines each for signals A and B. Differential encoders greatly reduce susceptibility to electrical noise and they can be powered from 5 V to 24 V.

Encoder Wiring

If your sensor is configured for encoder input, you can connect both differential and single-ended encoders. Using an encoder allows you to specify input and output delay values in pulse counts instead of real time units. The image below shows the wiring of a single-ended encoder.

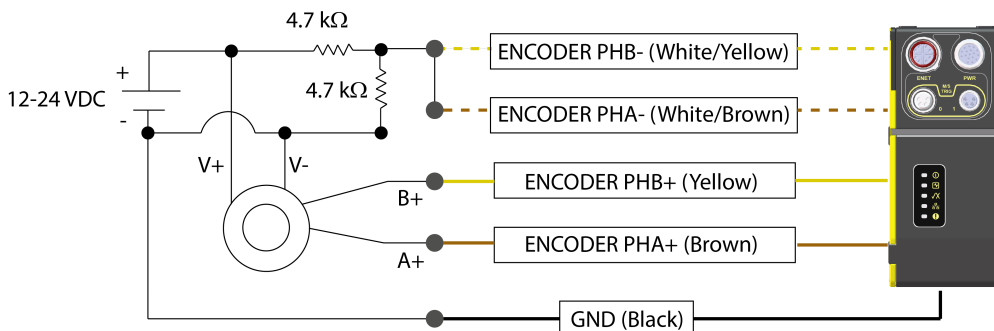

The image below shows the wiring of a differential encoder.

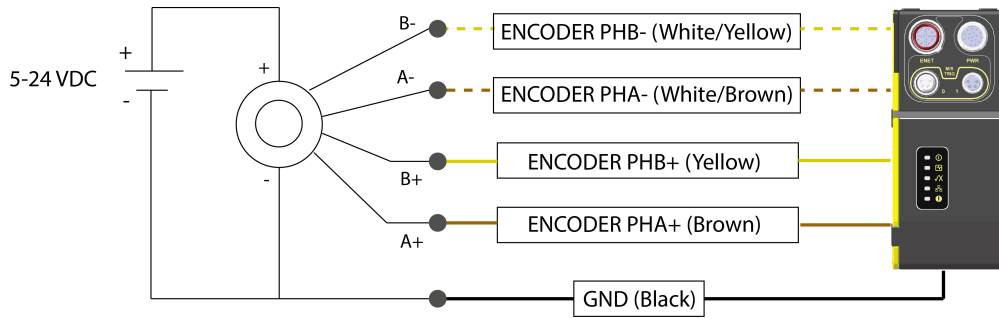

CAUTION: Encoder and power **MUST** share the same ground.

Trigger and Laser Enable Inputs

The acquisition trigger and laser enable inputs to the sensor are opto-isolated. The sensor responds to a trigger event when the voltage difference between the TRIGGER and IN COMMON inputs exceed 10 V. The laser enable input is enabled when the difference between the LASER ENABLE and IN COMMON inputs exceed 10 V.

To configure the acquisition trigger and laser enable as NPN (current sinking) inputs, connect the TRIGGER and LASER ENABLE terminals to the output of the sensors and the IN COMMON terminal to the return of the sensor. The TRIGGER or LASER ENABLE terminal set to a high voltage level (12 V -24 V) causes the current flow through the LED emitter of the opto-isolator, turning on the corresponding opto-coupler output.

To configure the acquisition trigger and laser safety as PNP (current sourcing) inputs, connect the TRIGGER and LASER ENABLE terminals to the return of the sensors and the IN COMMON terminal to the sensor voltage reference (12 V-24 V). The TRIGGER or LASER ENABLE terminal set to ground level (12V – 24V) causes the current to flow through the LED emitter of the opto-isolator, turning on the corresponding opto-coupler output.

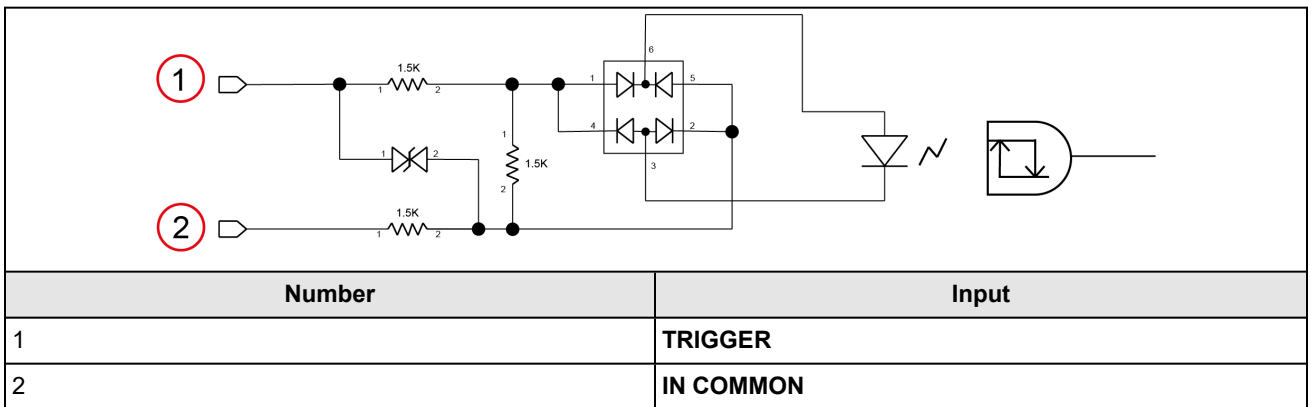

Trigger and Laser Enable Wiring

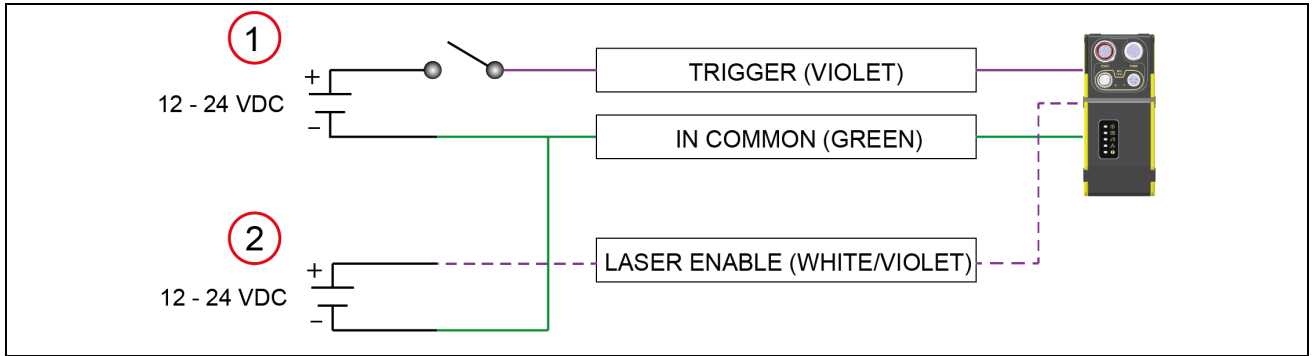

Number	Component
1	Trigger (Sensor Sinks Current - NPN)
2	Laser Enable (Sensor Sinks Current - NPN)

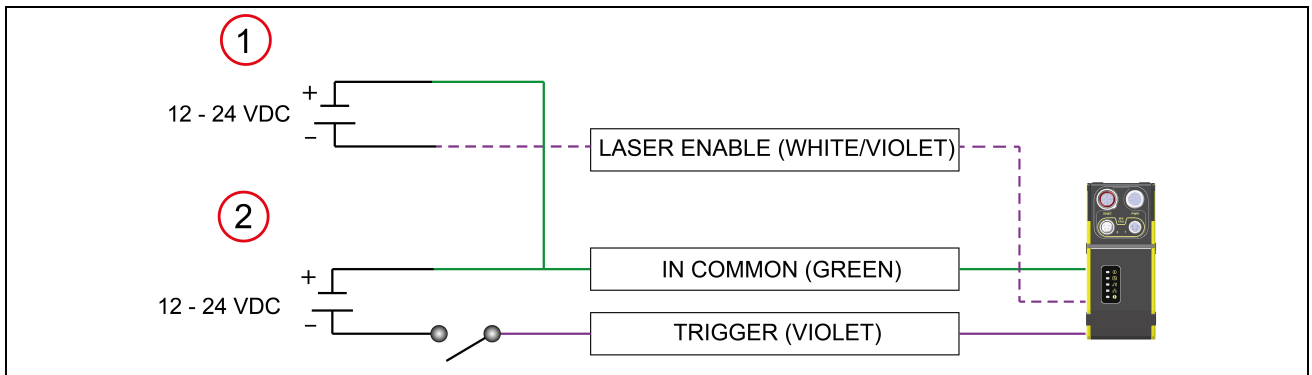

Number	Component
1	Trigger (Sensor Sources Current - PNP)
2	Laser Enable (Sensor Sources Current- PNP)

Outputs

The VisionPro 3D-L4000 series sensors do not support optically isolated outputs.

Laser Models

The following sensors contain a class 2M laser:

Model	Class 2M Laser
3D-L4033	✓
3D-L4050	
3D-L4100	
3D-L4300	

Laser Compliance

 **WARNING:** Laser light, do not stare into beam: Class 2M laser product. Failure to follow these instructions may cause serious injury.

Cognex places the following labels on every 3D-L4000 series 3D sensor:

- Blue laser:



Complies with FDA performance standards for laser products except for conformance with IEC 60825-1 Ed. 3, as described in Laser Notice No. 56, dated May 8, 2019

- Red laser:



Complies with FDA performance standards for laser products except for conformance with IEC 60825-1 Ed. 3, as described in Laser Notice No. 56, dated May 8, 2019.

 **WARNING:** Use of controls or adjustments or performance of procedures other than those specified herein may result in hazardous radiation exposure.

Blue Laser Specification	3D-L4050	3D-L4100	3D-L4300
Wavelength	450 nm +/- 10 nm		
½ Angle Beam Divergence	W0 1.54	W0 0.93	W0 0.80
Pulse Duration	Varies to DC		
Maximum Power	<5mW accessible power		

Laser Safety Warnings

- Do not stare into the beam.
- Do not view directly with optical instruments (magnifiers).
- Do not place optical components (mirrors) into the beam.
- Design test fixtures in such a way that unintentional viewing of the beam is prevented.
- Switch off the laser when not in use.
- Avoid the use of highly reflective materials. If you cannot, try to angle the part so unintentional viewing of the reflection is prevented.
- Terminate (block) unused beams.
- Keep the laser plane horizontal or pointing downwards.
- Report any issues that may have an impact on laser safety to your supervisor or Laser Safety Officer.
- There is no scheduled maintenance necessary to keep the product in compliance.
- Under no circumstances should you operate the sensor if it is defective or the seal damaged. Cognex Corporation cannot be held responsible for any harm caused by operating a faulty unit.
- Under no circumstances should you modify in any way the sensor or its housing.
- Use of controls or adjustments or performance of procedures other than those specified herein may result in hazardous radiation exposure.
- When moving the unit from a very hot environment to a cold environment please allow the unit to equalize in a room temperature environment for 2 hours between temperature extremes.

Label Locations

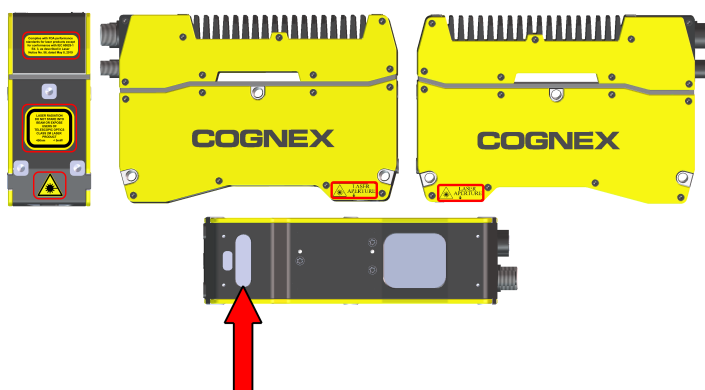

 **WARNING:** Laser light, do not stare into beam: Class 2M laser product. Failure to follow these instructions may cause serious injury.



 **WARNING:** Avoid exposure - laser radiation is emitted from this aperture.

Regulations and Conformity

Note: For the most current CE declaration and regulatory conformity information, see the Cognex support site: cognex.com/support.

Manufacturer	Cognex Corporation One Vision Drive Natick, MA 01760 USA
	3D-L4033: Regulatory Model 50203 3D-L4050: Regulatory Model 50203 3D-L4100: Regulatory Model 50203 3D-L4300: Regulatory Model 50203 This is a class A product. In a domestic environment this product may cause radio interference in which case the user may be required to take immediate measures. This equipment complies with the essential requirements of the EU Directive 2014/30/EU. Declarations are available from your local representative.
EU RoHS	Compliant to the most recent applicable directive.
FCC	FCC Part 15, Class A This equipment has been tested and found to comply with the limits for a Class A digital device, pursuant to part 15 of the FCC Rules. These limits are designed to provide reasonable protection against harmful interference when the equipment is operated in a commercial environment. This equipment generates, uses, and can radiate radio frequency energy and, if not installed and used in accordance with the instruction manual, may cause harmful interference to radio communications. Operation of this equipment in a residential area is likely to cause harmful interference in which case the user will be required to correct the interference at his own expense.
Laser Safety Certification	IEC 60825-1 US FDA CDRH Filing
Korea 	3D-L4033: Regulatory Model 50203: R-R-CGX-50203 3D-L4050: Regulatory Model 50203: R-R-CGX-50203 3D-L4100: Regulatory Model 50203: R-R-CGX-50203 3D-L4300: Regulatory Model 50203: R-R-CGX-50203 This device is certified for office use only and if used at home, there can be frequency interference problems.
TÜV	3D-L4033: Regulatory Model 50203 3D-L4050: Regulatory Model 50203 3D-L4100: Regulatory Model 50203 3D-L4300: Regulatory Model 50203 NRTL: TÜV SÜD SCC/NRTL OSHA Scheme for UL/CAN 61010-1. CB report available upon request. TÜV SÜD, IEC/EN 61010-1.

China RoHS



	Hazardous Substances 有害物质					
Part Name 部件名称	Lead (Pb) 铅	Mercury (Hg) 汞	Cadmium (Cd) 镉	Hexavalent Chromium (Cr (VI)) 六价铬	Polybrominated biphenyls (PBB) 多溴联苯	Polybrominated diphenyl ethers (PBDE) 多溴二苯醚
Regulatory Model 50203	X	O	O	O	O	O

This table is prepared in accordance with the provisions of SJ/T 11364.

这个标签是根据SJ/T 11364 的规定准备的。

O: Indicates that said hazardous substance contained in all of the homogeneous materials for this part is below the limit requirement of GB / T26572 - 2011.

表示本部件所有均质材料中含有的有害物质低于GB / T26572 - 2011 的限量要求。

X: Indicates that said hazardous substance contained in at least one of the homogeneous materials used for this part is above the limit requirement of GB / T26572 - 2011.

表示用于本部件的至少一种均质材料中所含的危害物质超过GB / T26572 - 2011 的限制要求。

For European Community Users

Cognex complies with Directive 2012/19/EU OF THE EUROPEAN PARLIAMENT AND OF THE COUNCIL of 4 July 2012 on waste electrical and electronic equipment (WEEE).

This product has required the extraction and use of natural resources for its production. It may contain hazardous substances that could impact health and the environment, if not properly disposed.

In order to avoid the dissemination of those substances in our environment and to diminish the pressure on the natural resources, we encourage you to use the appropriate take-back systems for product disposal. Those systems will reuse or recycle most of the materials of the product you are disposing in a sound way.



The crossed out wheeled bin symbol informs you that the product should not be disposed of along with municipal waste and invites you to use the appropriate separate take-back systems for product disposal.

If you need more information on the collection, reuse, and recycling systems, please contact your local or regional waste administration.

You may also contact your supplier for more information on the environmental performance of this product.

Product Service

- Bring any performance issues to the attention of your Cognex sales representative.
- The sensor can only be serviced by a trained Cognex representative. Return the unit to Cognex for any service or repairs.
- Do not operate the sensor if the enclosure appears damaged.

