

Edge Intelligence Hardware Reference Manual

2025 March 14
Revision: 2.2.0.13

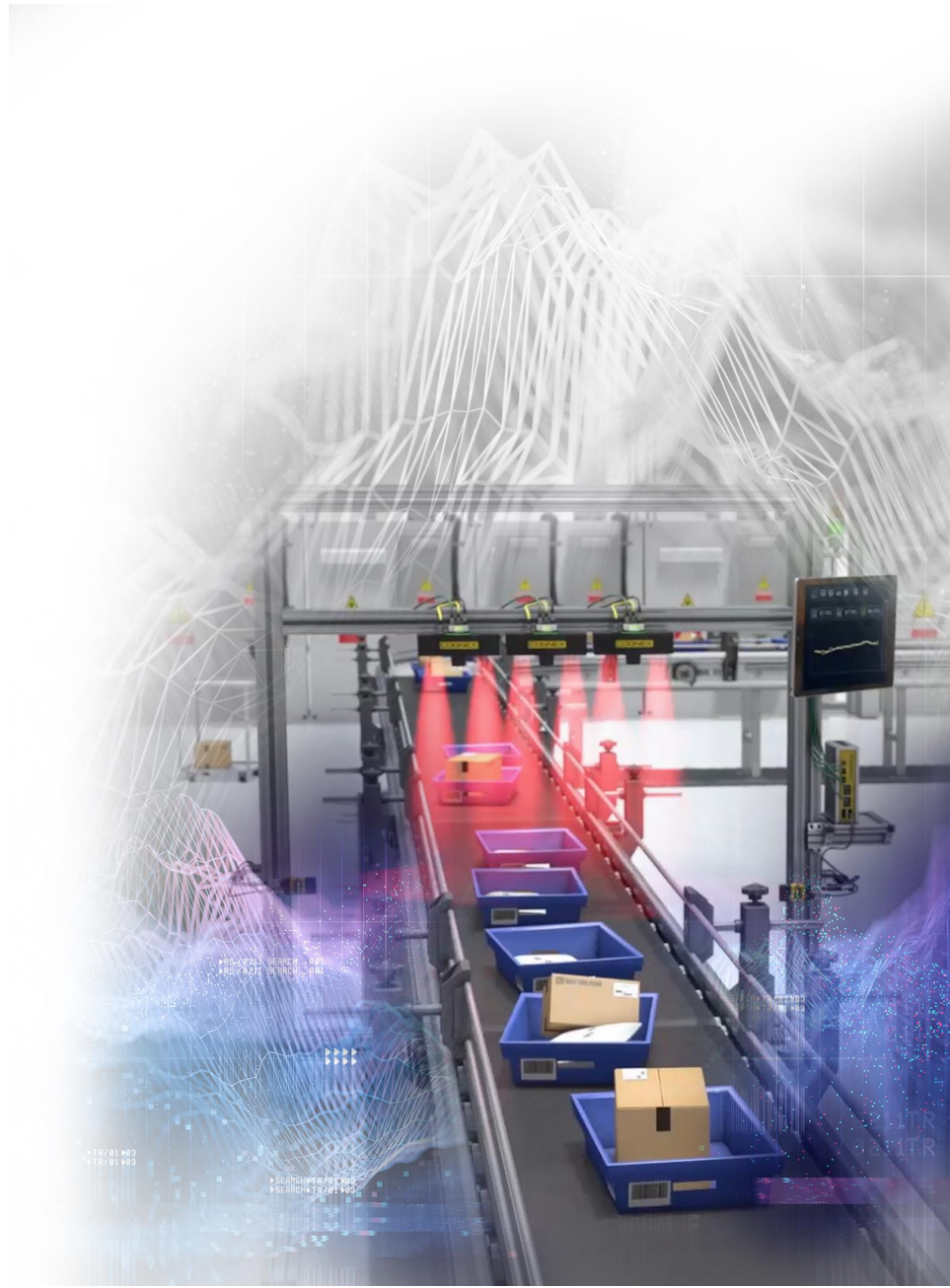

Table of Contents

Table of Contents	2
Legal Notices	3
Precautions	4
Symbols	5
Getting Started	6
About Edge Intelligence	6
Accessories	6
Setting Up Edge Intelligence	8
Layout	9
Dimensions	10
Wall Mounting	11
Connection Options	12
Connecting the Network and Power Cables	12
Directly Connecting Using a Monitor	13
Accessing the Web Interface and Logging In	13
Remote Connection Troubleshooting	14
Specifications	16
Cleaning and Maintenance	18
Regulations and Conformity	19

Legal Notices

The software described in this document is furnished under license, and may be used or copied only in accordance with the terms of such license and with the inclusion of the copyright notice shown on this page. Neither the software, this document, nor any copies thereof may be provided to, or otherwise made available to, anyone other than the licensee. Title to, and ownership of, this software remains with Cognex Corporation or its licensor. Cognex Corporation assumes no responsibility for the use or reliability of its software on equipment that is not supplied by Cognex Corporation. Cognex Corporation makes no warranties, either express or implied, regarding the described software, its merchantability, non-infringement or its fitness for any particular purpose.

The information in this document is subject to change without notice and should not be construed as a commitment by Cognex Corporation. Cognex Corporation is not responsible for any errors that may be present in either this document or the associated software.

Companies, names, and data used in examples herein are fictitious unless otherwise noted. No part of this document may be reproduced or transmitted in any form or by any means, electronic or mechanical, for any purpose, nor transferred to any other media or language without the written permission of Cognex Corporation.

Copyright © 2025. Cognex Corporation. All Rights Reserved.

Portions of the hardware and software provided by Cognex may be covered by one or more U.S. and foreign patents, as well as pending U.S. and foreign patents listed on the Cognex web site at: cognex.com/patents.

The following are registered trademarks of Cognex Corporation:

Cognex, 2DMAX, Advantage, AlignPlus, Assemblyplus, Check it with Checker, Checker, Cognex Vision for Industry, Cognex VSOC, CVL, DataMan, DisplayInspect, DVT, EasyBuilder, Hotbars, IDMax, In-Sight, Laser Killer, MVS-8000, OmniView, PatFind, PatFlex, PatInspect, PatMax, PatQuick, SensorView, SmartView, SmartAdvisor, SmartLearn, UltraLight, Vision Solutions, VisionPro, VisionView

The following are trademarks of Cognex Corporation:

The Cognex logo, 1DMax, 3D-Locate, 3DMax, BGAll, CheckPoint, Cognex VSoC, CVC-1000, FFD, iLearn, In-Sight (design insignia with cross-hairs), In-Sight 2000, InspectEdge, Inspection Designer, MVS, NotchMax, OCRMax, PatMax RedLine, ProofRead, SmartSync, ProfilePlus, SmartDisplay, SmartSystem, SMD4, VisiFlex, Xpand

Portions copyright © Microsoft Corporation. All rights reserved.

Portions copyright © MadCap Software, Inc. All rights reserved.

Other product and company trademarks identified herein are the trademarks of their respective owners.

Precautions

To reduce the risk of injury or equipment damage, observe the following precautions when you install the Cognex product:

- This product is intended for industrial use in automated manufacturing or similar applications.
- The safety of any system incorporating this product is the responsibility of the assembler of the system.
- Do not install Cognex products where they are exposed to environmental hazards such as excessive heat, dust, moisture, humidity, impact, vibration, corrosive substances, flammable substances, or static electricity. Observe the limitations of the ingress protection (IP) and vibration ratings of the device. For more information, see [Specifications on page 16](#).
- Removing the I/O panel cover and installing accessories can result in reduced system environmental ratings. Check with your Cognex representative for details.
- Route cables and wires away from high-current wiring or high-voltage power sources to reduce the risk of damage or malfunction from the following causes: over-voltage, line noise, electrostatic discharge (ESD), power surges, or other irregularities in the power supply.
- This product does not contain user-serviceable parts. Do not make electrical or mechanical modifications to product components. Unauthorized modifications can void your warranty.
Do not attempt to open the equipment, except for the external I/O cover. Removing any other screws, panels, or other parts can expose the user to risk of electric shock or damage the equipment.
- Changes or modifications not expressly approved by the party responsible for regulatory compliance could void the user's authority to operate the equipment.
- Include service loops with cable connections.
- Ensure that the cable bend radius begins at least six inches from the connector. Cable shielding can be degraded or cables can be damaged or wear out faster if a service loop or bend radius is tighter than 10X the cable diameter.
- This device should be used in accordance with the instructions in this manual.
- All specifications are for reference purposes only and can change without notice.
- Power off the equipment and de-energize the power supply before connecting devices to the power pass-through port to avoid damaging the equipment.
- Use only Cognex-approved cables and power supplies that have been indicated for use with this product. Do not use and de-energize any equipment that shows damage, such as bent pins, damaged insulation, or bulging.
- Before cleaning, turn off power and ensure that the system is at a safe temperature for handling. Follow the instructions in the [Cleaning and Maintenance on page 18](#) section.
- Do not operate or store this equipment in conditions outside of the specified ranges, as this can cause permanent damage to the equipment and void the warranty. For more information, see [Specifications on page 16](#).
- Do not open the back cover of the device. If opening the cover for maintenance is a must, note that integrated circuits on computer boards are sensitive to static electricity. To avoid damaging chips from electrostatic discharge, observe the following precautions:
 - Before handling a board or integrated circuit, touch an unpainted portion of the system unit chassis for a few seconds. This will help to discharge any static electricity on your body.
 - When handling boards and components, wear a grounding wrist strap, available from most electronic component stores.

Symbols

The following symbols indicate safety precautions and supplemental information:

 **WARNING:** This symbol indicates a hazard that could cause death, serious personal injury or electrical shock.

 **CAUTION:** This symbol indicates a hazard that could result in property damage.

 **Note:** This symbol indicates additional information about a subject.

 **Tip:** This symbol indicates suggestions and shortcuts that might not otherwise be apparent.

Getting Started

This section provides general information about the Edge Intelligence unit and accessories.

Note: All specifications and images are subject to change without notice.

About Edge Intelligence



Edge Intelligence is a software platform that powers both EI Station Manager and EI Tunnel Manager, providing real-time insights, analytics, and tools to optimize manufacturing and logistics operations.

The Edge Intelligence solution includes the on-premises Edge Intelligence industrial PC, a browser-based user interface, and the option to connect a screen for local control.

You can install the rugged, fanless Edge Intelligence unit without additional enclosures or protection thanks to its IP54 rating. The unit comes with 2.5 Gb network connectivity and a modern Intel® Core™ i3 processor. An upgraded version is available with an Intel® Core™ i9 processor for more demanding applications.

Accessories

You can purchase the following components separately. For a list of options and accessories, contact your local Cognex sales representative.

Accessory	Product Number
Ethernet Cable, X-coded M12-8 to RJ-45	CCB-84901-2001-xx (straight, xx specifies length: 2m, 5m, 10m, 15m, 30m)
Ethernet Cable, X-coded M12-8 to RJ-45	CCB-84901-2RBT-xx (straight, xx specifies length: 2m, 5m, 10m)
Ethernet Chain, X-coded	CCB-CIO-51001-xxx (xxx specifies length: 0.5m, 1m, 2m, 3m, 4m, 5m, 6m, 10m, 15m)
Emparro® Power Supply, 8A, 7/8", L-coded	CPS-8A-78-L
Emparro® Input, 7/8" to C14	CCB-CPS-A3E11-200 (2m)

Emparro [®] Two Channel Output, L-Coded	CCB-CPS-344533-xxx (xxx specifies length: 0.5m, 1m, 2m, 3m, 4m, 5m)
Screws (M6x18)	i Note: Usually ordered with frame from vendor
EI Monitor Kitting Package	DMA-EI-MONITOR-215
Power Chain, L-coded	CCB-CIO-P4141-xxx (xxx specifies length: 0.5m, 1m, 2m, 3m, 4m, 5m)

i Note: If a standard component is missing or damaged, immediately contact your Cognex Authorized Service Provider (ASP) or Cognex Technical Support.

Setting Up Edge Intelligence

Read this section to learn how the unit connects to its standard components and accessories.

Note:



- Cables are sold separately.
- If a standard component is missing or damaged, immediately contact your Cognex Representative or Cognex Technical Support.



CAUTION: All cable connectors are keyed to fit the connectors on the unit. Do not force the connections or damage may occur.

Layout

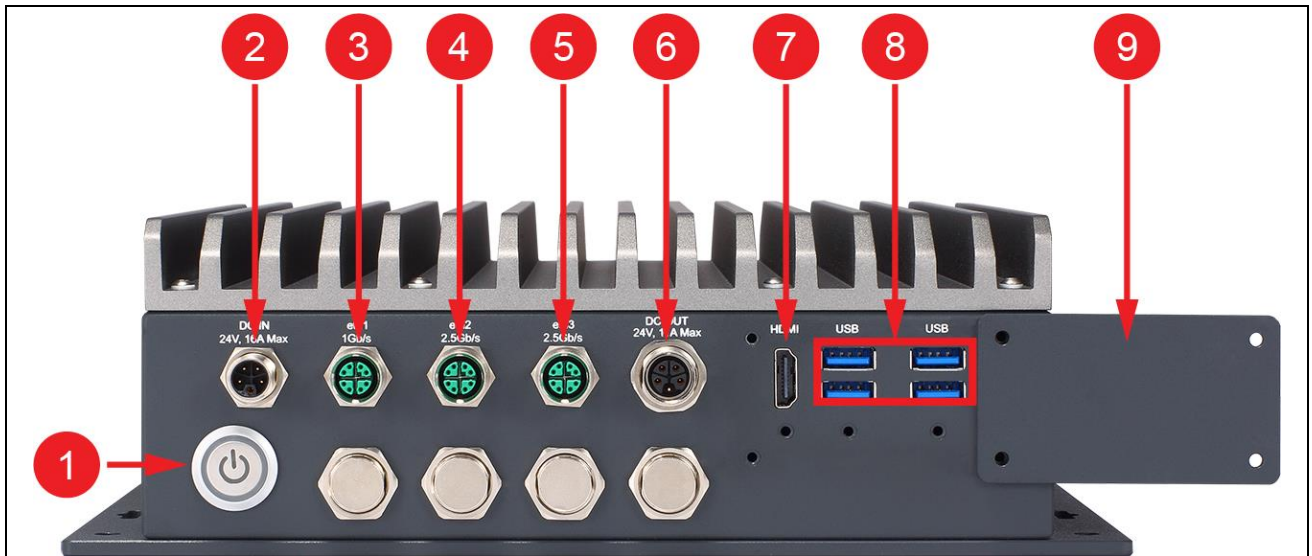

Number	Function
1	Power switch with LED
2	DC input
3	1 GbE external port (DHCP)
4	2.5 GbE internal port (192.168.1.100)
5	2.5 GbE internal port (DHCP default)
6	DC output
7	HDMI 1.4b with 4096 × 2160 resolution
8	4 × USB3.1 Gen1 (5G)
9	I/O cover plate

Note: Removing the plate changes the effective IP rating of the unit.

Dimensions

Observe the following dimensions when installing your Edge Intelligence unit.

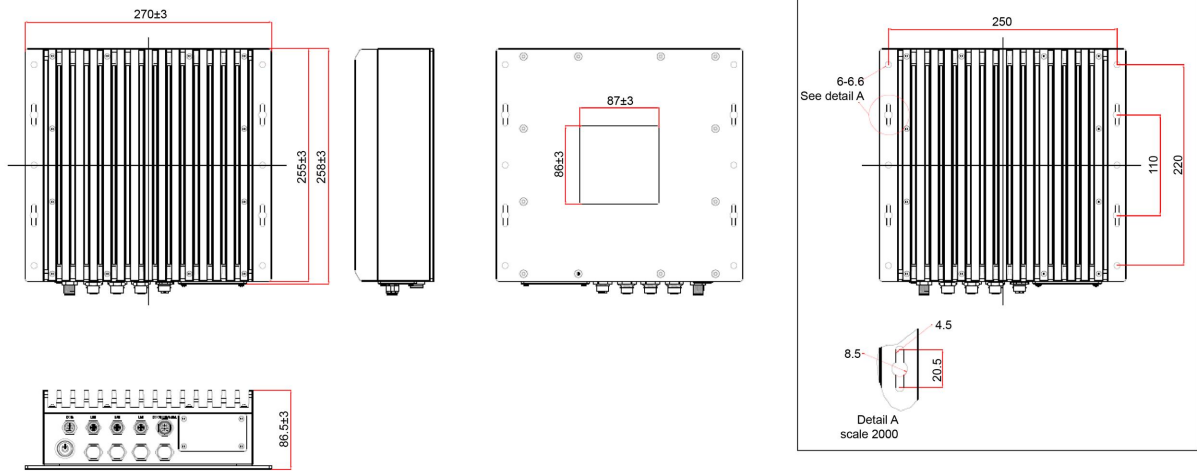

Note:

i Dimensions are in millimeters and are for reference purposes only.

All specifications are for reference purposes only and can change without notice.

Wall Mounting

The Edge Intelligence unit provides holes for wall mounting.

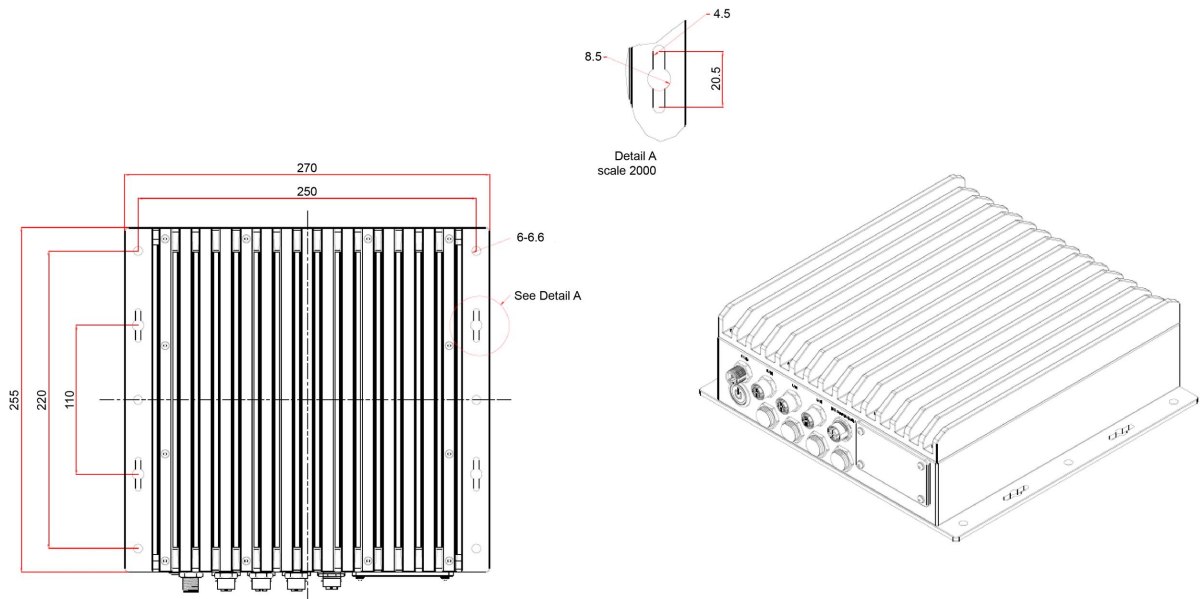

Connection Options

You can connect the Edge Intelligence unit to two network switches. One network connection, using static IP addressing, typically connects to a unit with one or more devices. A second network connection is typically connecting to the network of the building, which allows maintenance and management staff to connect with and manage the Edge Intelligence system.

You have the following options for connecting to the Edge Intelligence unit:

- Connecting over the network:

Edge Intelligence unit has a web interface that you can reach over the network, either the local network or from other locations, depending on the network configuration.

- Connecting directly using a monitor:

You can plug a monitor into the Edge Intelligence unit, along with touchscreen controls, or keyboard and mouse. This allows you to access the system without a separate PC or network connection. In this mode, you can review results and statistics, configure the system, and use other applications installed on the unit.

Note: When directly connecting using a monitor, you cannot download or upload data from the Edge Intelligence unit. The download and upload buttons are disabled and hidden in the web user interface.

Connecting the Network and Power Cables

To connect the network and power cables:

1. Unpack your Edge Intelligence unit and ensure all components are included.
2. Connect the Edge Intelligence unit to your production network.
 - a. Connect to your network using Ethernet port 1 or 3.
 - b. Connect to your reader or vision system network LAN using Ethernet port 2.

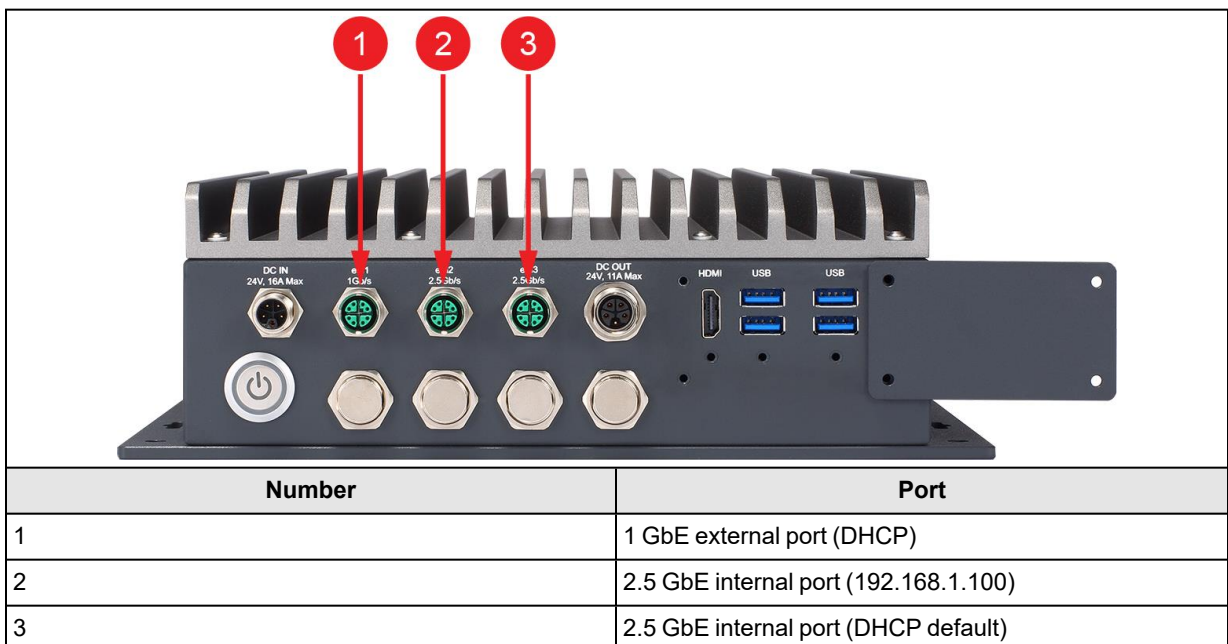

3. Connect the Edge Intelligence unit to a power source, using port 1 for power input and port 2 for power output.

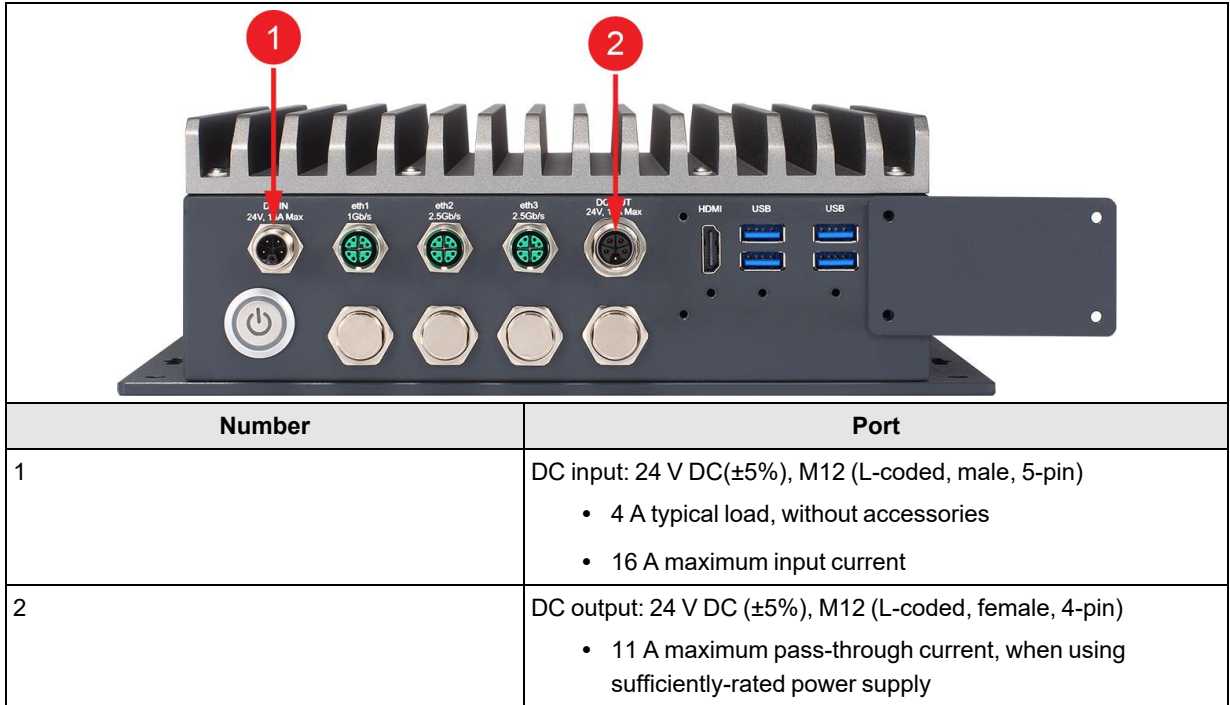

Directly Connecting Using a Monitor

To directly connect to the Edge Intelligence unit using a monitor:

1. To open the I/O cover plate covering the HDMI and USB ports:
 - a. Unscrew the screws from the I/O cover plate.
 - b. Remove the I/O cover plate, or rotate the I/O cover plate to expose the connectors.

Note: To avoid losing components, you can rotate the I/O cover plate by 180 degrees. For more information, see [Layout on page 9](#).

2. Connect the monitor to the Edge Intelligence unit using an HDMI cable.
3. Connect the peripherals such as a mouse and keyboard to the Edge Intelligence unit using the USB ports.
4. Turn on the Edge Intelligence unit.
5. The Edge Intelligence login page appears.

You can sign in using your credentials.

If this is the first time you are logging in, use the default predefined credentials. For more information, see the *Logging In* section in the Reference Manual of your Edge Intelligence software product.

6. Option: If you plan to remotely access the Edge Intelligence unit, click the information icon on the login page and note down the external IP address of the unit.

Accessing the Web Interface and Logging In

After connecting the Edge Intelligence unit to the network and powering it on, you can connect to the unit from any computer on the network using the web browser.

To access the web interface:

1. Turn on the Edge Intelligence unit.
2. Open the browser on the computer you are using to connect to the Edge Intelligence unit.
3. Type the external IP address of the Edge Intelligence unit into the search bar.



If the connection is successful, the Edge Intelligence login page appears in the browser.

You can sign in using your credentials.

If this is the first time you are logging in, use the default predefined credentials. For more information, see the *Logging In* section in the Reference Manual of your Edge Intelligence software product.

Remote Connection Troubleshooting

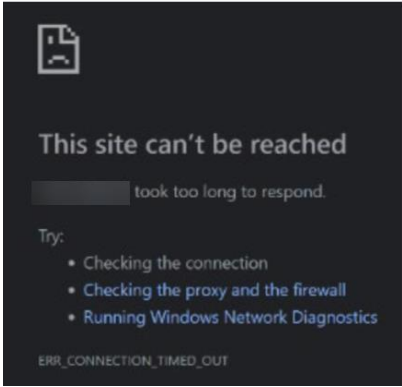
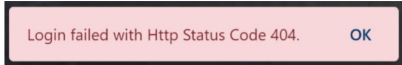
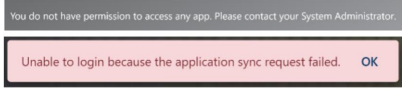
This section lists the most common errors and their solutions.

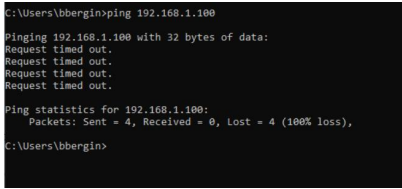
Error	Illustration	Solution
Edge Intelligence is not visible in the browser		Check cable connections and secure them if necessary.
Failed login error message		Check the credentials and reenter username and/or password.
Component load error message		Reboot unit and wait for services to start.
No data/images available		Check unit availability and setup.
Cannot access Edge Intelligence URL		Check that subnets do not overlap. The network administrator must ensure that the IPs do not overlap.

Note: For the best results, use Ethernet connection to your network, because Wi-Fi might not allow the connection depending on your network settings.

Note:
The login page lists the IP address of your devices.



About El-DemoUnit

Documentation

[Click here to open documentation.](#)

Network Interfaces

Name	Operational	MAC Address	Address Type	IP Address	Subnet Mask	Gateway	DNS Server	Domain
	✓		DHCP					(none)
	✓		DHCP					(none)
	✓		Static					(none)

Specifications

Category	Specification	
	EI-A3 Series	EI-A9 Series
Standard Color	Silver and black	
Construction	Aluminum extrusion heavy-duty cold-rolled steel	
Processor	Intel® 13th generation i3-12100TE (35 W, 2.1 GHz performance core base frequency)	Intel® 12th generation i9-13100T (35 W, 2.5 GHz performance core base frequency)
	<p>Note:</p> <ul style="list-style-type: none"> The IPC system might cause CPU frequency hopping when operating in an extremely high temperature environment. Thermal throttling can occur when the system remains in full loading conditions. The performance of the system might be adversely affected when operating at a temperature above the limitation of the system. 	
Memory	8 GB	16 GB
Ethernet	2 × 2.5 GbE LAN (Intel® I226-V, M12 X-coded) 1 × 1 GbE LAN (Intel® I219-LM, M12 X-coded)	
USB	4 × USB3.2 Gen1x1 (5G) type A	
Display	1 × HDMI 1.4b with 4096 × 2160 resolution supported	
TPM	1 × TPM 2.0 on board	
Storage	256 GB M.2 SSD, wide temperature	1 TB M.2 SSD, wide temperature
Power input	<ul style="list-style-type: none"> DC input: 24 V DC(±5%), 16 A, M12 (L-coded, male, 5-pin), 4 A typical load, without accessories DC output: 24 V DC (±5%), 11 A, M12 (L-coded, female, 4-pin), 11 A maximum pass-through current, when using sufficiently-rated power supply 1 x power switch with LED 	
Typical	24 V DC	
Power rating	24 V DC, 16 A	
	<p>Note: The system power rating might change based on differing combinations of attached devices.</p>	
Operating Temperature	-20 °C to 40 °C, with 10% to 95% non-condensing relative humidity. Includes an industrial wide-temperature SSD and requires 0.7 m/s air flow	
Storage Temperature	-40 °C to 70 °C, with 10% to 95% non-condensing relative humidity	
IP Rating	IP54	
Vibration	Operational: 3 Grms, 2 hr/axis, 10-500 Hz Shipment: 2.25 Grms, 2 hr/axis, 10-500 Hz	
Shock	IEC 60068-2-27 (with SSD: 50G, half sine, 11 ms duration)	
Dimensions	270 × 255 × 86.5 mm (including embedded wall mount)	
Weight (net/gross)	4.8 kg/5.5 kg	

Regulations/Conformity	CE, FCC, UL, CB, KC, CCC, BIS, VCCI i Note: For more information, see Regulations and Conformity on page 19 .
------------------------	--

Cleaning and Maintenance

To clean the outside of the unit housing, use a small amount of mild detergent cleaner or isopropyl alcohol on a cleaning cloth. Wipe external surfaces, avoiding exposed I/O ports if applicable. Do not pour the cleaner on the unit housing.

 **Note:** Turn off the unit and allow it to cool to a safe temperature before cleaning.

 **CAUTION:** Do not attempt to clean any Edge Intelligence product with harsh or corrosive solvents, including lye, methyl ethyl ketone (MEK) or gasoline.

Regulations and Conformity

Safety and Regulatory	
Model	Edge Intelligence
Certifications	Electromagnetic Compatibility Directive (2014/30/EU) Low Voltage Directive (2014/35/EU) Restriction of Hazardous substances Directive (2011/65/EU), (EU)2015/863 WEEE Directive (2012/19/EU) EN 55032:2015+A11:2020 EN 55035:2017+A11:2020 EN IEC 62368-1:2020+A11:2020
	CB Scheme IEC 62368-1:2018
	FCC 47 CFR Part 15 Subpart B ICES-002 Issue 7-2020 UL 62368-1, 3rd Ed CSA C22.2 No. 62368-1:19, 3rd Ed
	GB 17625.1-2022 GB 4943.1-2022 GB/T 9254.1-2021
	KS C 9832:2023 KS C 9835:2019
	VCCI-CISPR 32:2016
	IS 13252 (Part 1):2010+A1:2013+A2:2015 IEC 60950-1:2005+A1:2009+A2:2013
Manufacturer	Axiomtek Co., Ltd 18138 Rowland St. City of Industry, CA 91748 USA Elisabeth-Selbert-Str. 21a, D-40764 Langenfeld, Germany

