

Edge Intelligence Station Manager Reference Manual

2024 April 18
Revision: 1.2.0.37

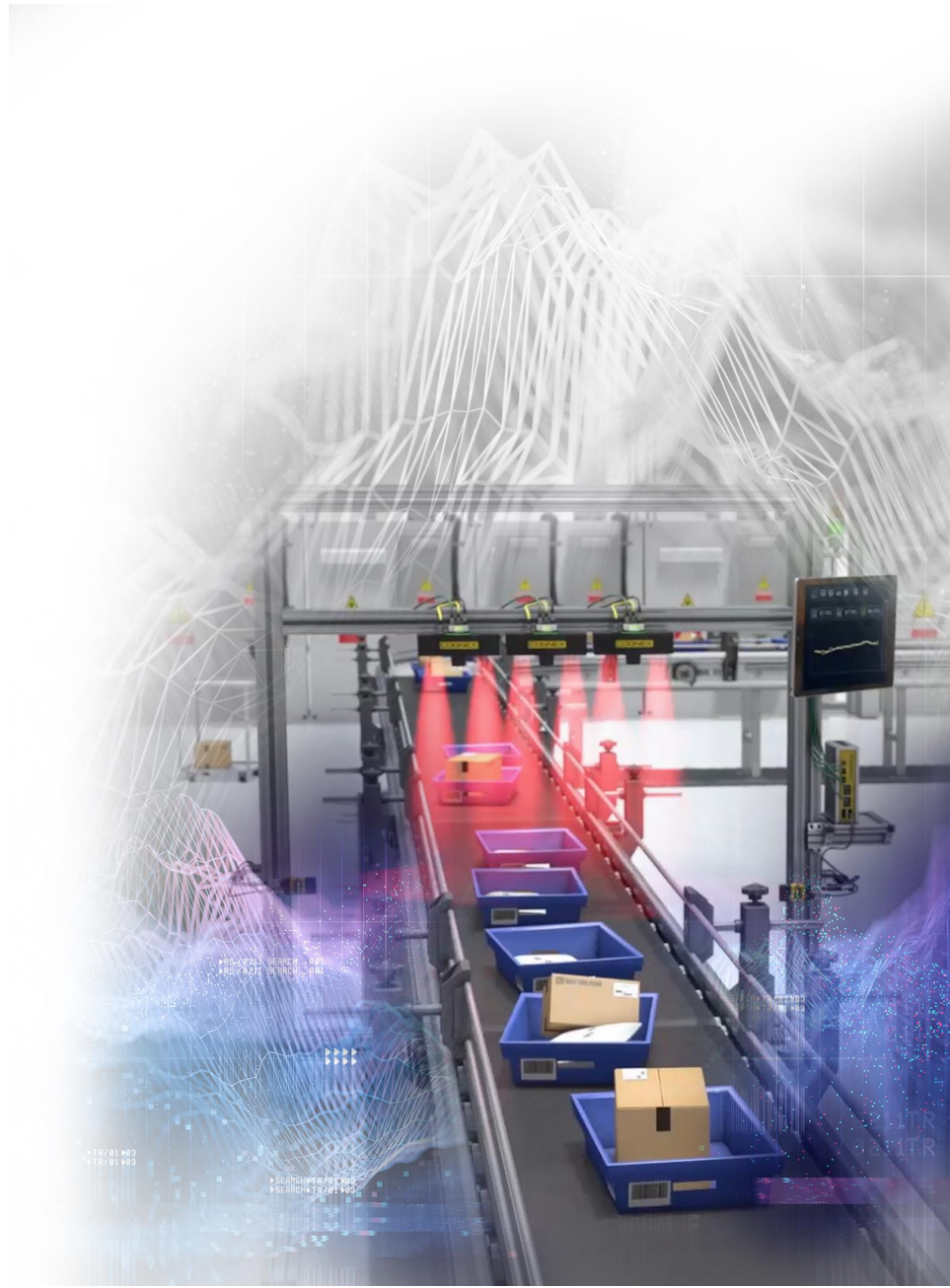

Table of Contents

Table of Contents	2
Legal Notices	4
Precautions	5
Symbols	6
Getting Started	7
About Station Manager	7
Edge Intelligence Station Manager Features	8
Installation	9
Connecting the EI Station Manager	9
Connecting to Edge Intelligence Station Manager	9
Directly Connecting Using a Monitor	9
Remotely Connecting Using a Browser	10
Virtual Machine-Based Installation	10
Discovering Devices on the Network	20
Discover Devices	20
Network Settings	20
Remote Connection Troubleshooting	21
EI Station Manager User Interface	22
Ribbon Elements	22
Performance Analytics	23
Dashboard	23
Edit Dashboard	24
Results Explorer	25
Events	28
Configuration Change History	28
Configuration Changes	30
Reporting	33
Generate	33
Individual Report Actions	35
Provisioning	36
DataMan	36
Device Actions	36
Provisioning Devices	37
Provision Device by IP	37
Data Collection Settings	38
Remote Subnets	38
Device Management	39
DataMan	39
Individual Device Actions	41
Device Group Actions	41

DataMan WebHMI	43
Feature Keys	48
Archiver	50
Download Center	50
Extract a Single Archive File	52
Extract a Multi-Archive File	53
Settings	55
Edge Device	55
Setting up the NAT	57
NTP Server Function	58
DataMan WebHMI	58
Firmware Upgrade	59
HTTPS	61
User Management	62
Users	62
Roles	64
Single Sign-On	64
Identity Provider Configuration	65
Role Mapping	65
Cloud Forwarding	67
Connections	68
Connection Manager	69
Data Transfer	70
Data Forwarding	70
Notification Center	75
Notification Center Features	76
Notification Levels	79
Notification List	79
Licensing	83
Update	83
Software Upgrade	85
Using the Firmware Upgrade App	85
Using the DataMan Setup Tool	85
Open Source Licenses	89

Legal Notices

The software described in this document is furnished under license, and may be used or copied only in accordance with the terms of such license and with the inclusion of the copyright notice shown on this page. Neither the software, this document, nor any copies thereof may be provided to, or otherwise made available to, anyone other than the licensee. Title to, and ownership of, this software remains with Cognex Corporation or its licensor. Cognex Corporation assumes no responsibility for the use or reliability of its software on equipment that is not supplied by Cognex Corporation. Cognex Corporation makes no warranties, either express or implied, regarding the described software, its merchantability, non-infringement or its fitness for any particular purpose.

The information in this document is subject to change without notice and should not be construed as a commitment by Cognex Corporation. Cognex Corporation is not responsible for any errors that may be present in either this document or the associated software.

Companies, names, and data used in examples herein are fictitious unless otherwise noted. No part of this document may be reproduced or transmitted in any form or by any means, electronic or mechanical, for any purpose, nor transferred to any other media or language without the written permission of Cognex Corporation.

Copyright © 2023. Cognex Corporation. All Rights Reserved.

Portions of the hardware and software provided by Cognex may be covered by one or more U.S. and foreign patents, as well as pending U.S. and foreign patents listed on the Cognex web site at: cognex.com/patents.

The following are registered trademarks of Cognex Corporation:

Cognex, 2DMAX, Advantage, AlignPlus, Assemblyplus, Check it with Checker, Checker, Cognex Vision for Industry, Cognex VSOC, CVL, DataMan, DisplayInspect, DVT, EasyBuilder, Hotbars, IDMax, In-Sight, Laser Killer, MVS-8000, OmniView, PatFind, PatFlex, PatInspect, PatMax, PatQuick, SensorView, SmartView, SmartAdvisor, SmartLearn, UltraLight, Vision Solutions, VisionPro, VisionView

The following are trademarks of Cognex Corporation:

The Cognex logo, 1DMax, 3D-Locate, 3DMax, BGAll, CheckPoint, Cognex VSoC, CVC-1000, FFD, iLearn, In-Sight (design insignia with cross-hairs), In-Sight 2000, InspectEdge, Inspection Designer, MVS, NotchMax, OCRMax, PatMax RedLine, ProofRead, SmartSync, ProfilePlus, SmartDisplay, SmartSystem, SMD4, VisiFlex, Xpand

Portions copyright © Microsoft Corporation. All rights reserved.

Portions copyright © MadCap Software, Inc. All rights reserved.

Other product and company trademarks identified herein are the trademarks of their respective owners.

Precautions

To reduce the risk of injury or equipment damage, observe the following precautions when you install the Cognex product:

- This product is intended for industrial use in automated manufacturing or similar applications.
- The safety of any system incorporating this product is the responsibility of the assembler of the system.
- Do not install Cognex products where they are exposed to environmental hazards such as excessive heat, dust, moisture, humidity, impact, vibration, corrosive substances, flammable substances, or static electricity.
- Route cables and wires away from high-current wiring or high-voltage power sources to reduce the risk of damage or malfunction from the following causes: over-voltage, line noise, electrostatic discharge (ESD), power surges, or other irregularities in the power supply.
- This product does not contain user-serviceable parts. Do not make electrical or mechanical modifications to product components. Unauthorized modifications can void your warranty.
- Changes or modifications not expressly approved by the party responsible for regulatory compliance could void the user's authority to operate the equipment.
- Include service loops with cable connections.
- Ensure that the cable bend radius begins at least six inches from the connector. Cable shielding can be degraded or cables can be damaged or wear out faster if a service loop or bend radius is tighter than 10X the cable diameter.
- This device should be used in accordance with the instructions in this manual.
- All specifications are for reference purposes only and can change without notice.

Symbols

The following symbols indicate safety precautions and supplemental information:

 **WARNING:** This symbol indicates a hazard that could cause death, serious personal injury or electrical shock.

 **CAUTION:** This symbol indicates a hazard that could result in property damage.

 **Note:** This symbol indicates additional information about a subject.

 **Tip:** This symbol indicates suggestions and shortcuts that might not otherwise be apparent.

Getting Started

About Station Manager

EI Station Manager is a performance monitoring tool that collects and analyzes data generated by Cognex devices. EI Station Manager provides reader statistics, no read images, trigger details, and configuration changes for all connected devices.

The EI Station Manager solution is a software package running on a virtual machine, accessible through a browser-based user interface that provides access to the EI Station Manager functions.

EI Station Manager provides the following features through the UI:

- **Performance Analytics**
 - Dashboard
 - Results Explorer
- **Events**
 - Configuration Change History
- **Reporting**
 - Generate
- **Provisioning**
 - DataMan
 - Remote Subnets
- **Device Management**
 - DataMan
 - Feature Keys
- **Archiver**
 - Download Center
- **Settings**
 - Edge Device
 - MQTT Forwarding
 - DataMan WebHMI
 - Firmware Upgrade
 - HTTPS
- **User Management**
 - Users
 - Roles
- **Single Sign-On**
 - Identity Provider Configuration
 - Role Mapping

- **Cloud Forwarding**
 - Connections
 - Connection Manager
- **Data Transfer**
 - Data Forwarding
- **Notification Center**
- **Licensing**
 - Update

Supported DataMan readers compatible with EI Station Manager:

Device	Minimum Firmware Needed
• DM 260 series	5.7.3 or higher
• DM 370 series • DM 470 series	6.1.x or higher
• DM 80 series • DM 280 series	6.3.x or higher
• DM 380 series	6.5.x or higher
• DM 580 series	6.4.x or higher

Edge Intelligence Station Manager Features

EI Station Manager collects data and tracks reader configuration changes in real time, monitors performance, and provides data analysis to help identify root causes and facilitate quick action. The entire functionality of EI Station Manager is accessible from a browser. EI Station Manager has an intuitive user interface, no coding knowledge is required to use.

Main Features	Key elements
Device Management	Large storage for multi-day images/results
	Network, NAT
	Time Synchronization
Compatibility with DataMan Readers	Configurations, Firmware, Feature Keys
	Multi-Reader Sync group setup
	DataMan WebHMI to configure readers
Flexible and scalable solution: Integration with Industrial Analytics	Device results, and metadata
	Built-in MQTT/Sparkplug protocol (Ignition, Cloud providers) and analytics
Powerful Performance Monitoring tools	Real time performance with live dashboard
	Custom performance dashboards
	View and automatic categorization of Good Reads, No Reads, and Failed Validations
	Real time Device Configuration changes

Installation

This section describes the installation process.

Connecting the EI Station Manager

If you ordered the EI-300 or EI-700 Industrial PC (IPC), unpack your EI Station Manager unit and check that the following components have been included: power cable, display port to VGA adapter, and DIN rail mounting kit.

Perform the steps below before connecting to the web user interface:

1. Connect EI Station Manager unit to your Enterprise network using the External Ethernet port.

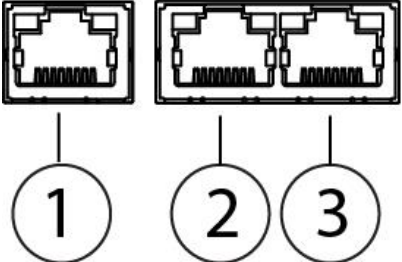
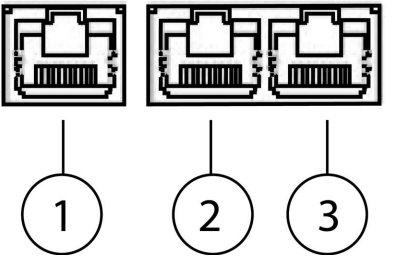
		
Number	EI-300	EI-700
1	External (DHCP)	External (DHCP)
2	Internal (192.168.1.100)	Internal (192.168.1.100)
3	Internal (DHCP default)	Internal (DHCP default)

2. Connect the IPC unit to your reader network LAN using the Internal Ethernet port.
3. Connect the IPC unit to power and start the device.

Connecting to Edge Intelligence Station Manager

You can connect to EI Station Manager in the following ways:

- Connect to the device locally using a monitor.
- Access the device remotely on your corporate network using the DataMan Setup Tool.
- Access the device remotely on your corporate network using a browser.

The following predefined user is available by default with the following default password:

Note: To avoid security risks, change the default passwords after the first login.

User	Password	Default Permissions
admin	BnthWWSD	Has access to all apps and features.

Directly Connecting Using a Monitor

1. Connect your EI Station Manager unit to a monitor using the provided Display Port to VGA adapter, or mini Display Port to VGA adapter when connecting the EI Station Manager box.

- The login page appears.

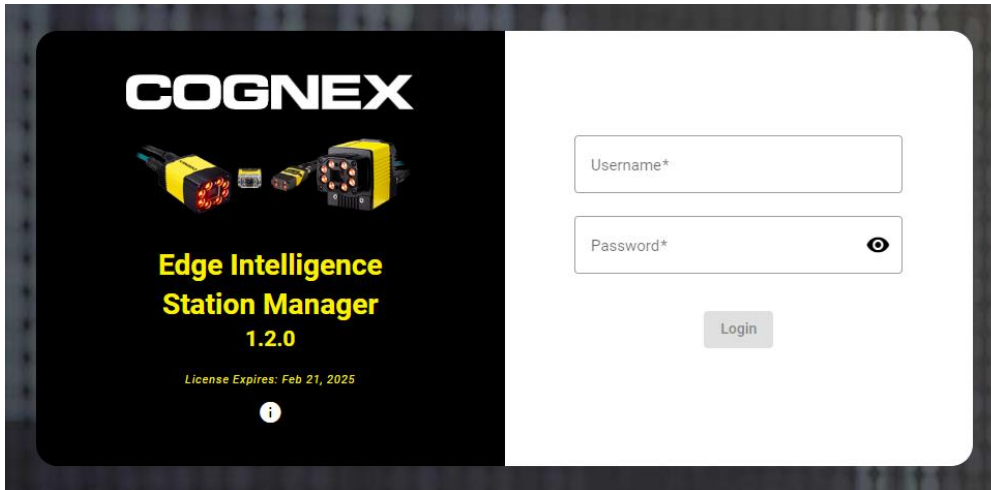

- Click the information icon to get the external IP address. The internal IP address is **192.168.1.100** by default.



- Take note of the external IP address, as you will need it to remotely connect to EI Station Manager.

About EI-DemoUnit

Documentation

[Click here to open documentation.](#)

Network Interfaces

Name	Operational	MAC Address	Address Type	IP Address	Subnet Mask	Gateway	DNS Server	Domain
	✓		DHCP					(none)
	✓		DHCP					(none)
	✓		Static					(none)

Remotely Connecting Using a Browser

To log into EI Station Manager using a browser:

- Open your browser and enter the IP address of the EI Station Manager. If you do not know the IP address, you can check by connecting directly or through the DataMan Setup Tool.
- Log into the EI Station Manager software using the credentials in [Connecting to Edge Intelligence Station Manager on page 9](#).

Virtual Machine-Based Installation

You can install a EI Station Manager virtual machine on VMware vSphere.

Minimum requirements:

- VMware vSphere version 6.5 or later
- VM requirements:
 - 4 CPU cores
 - 8 GB RAM
 - At least 200 GB storage

To create the EI Station Manager virtual machine:

1. Right-click on the cluster or host in the vSphere inventory, and select **Deploy OVF Template...** to begin the installation process.

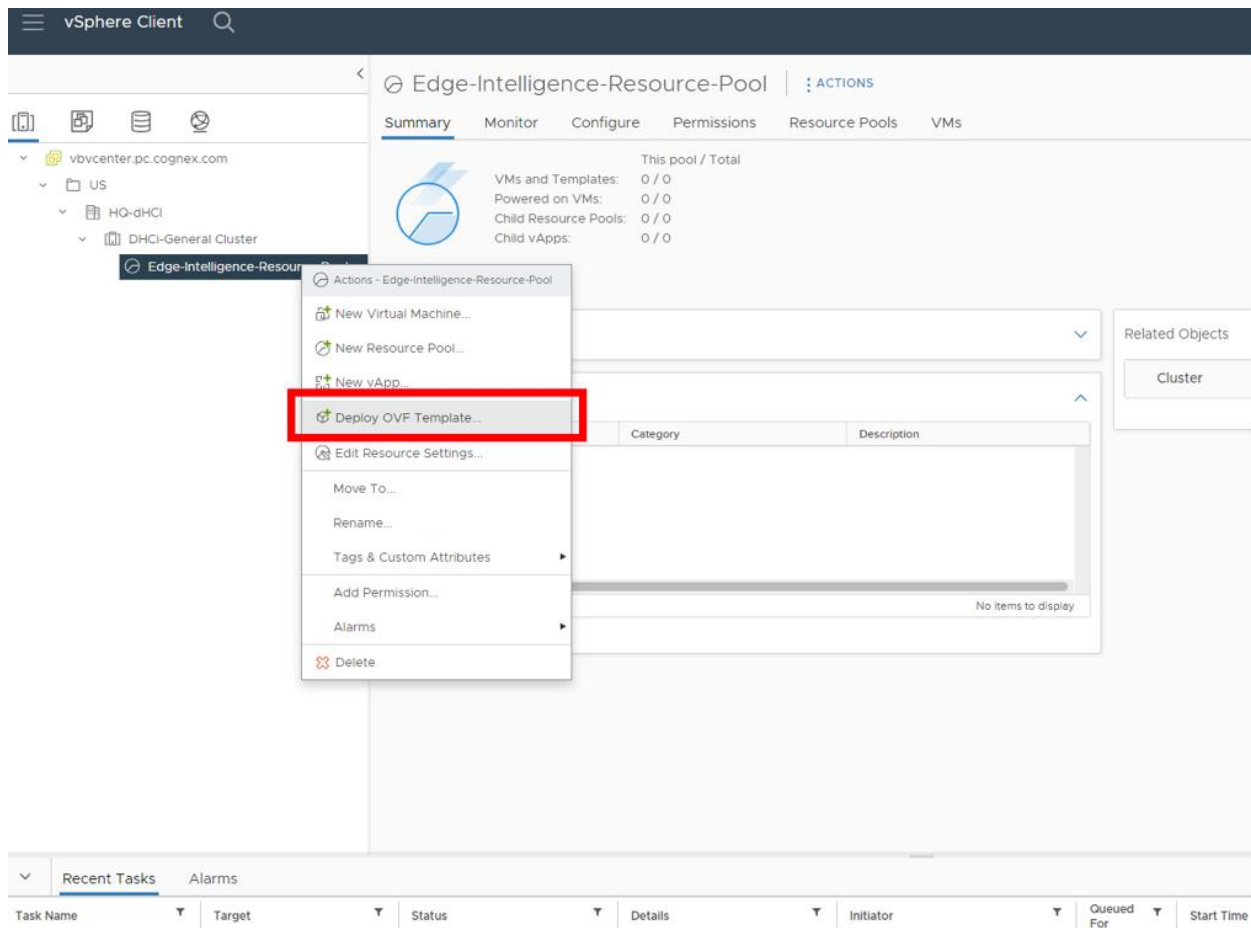

2. Choose **URL** or **Local file**. For the URL, enter the full path to the .ova file location. For the local file system, click **Upload Files** and select the *cognex-station-manager.ova* file.

The screenshot shows a web-based wizard titled "Deploy OVF Template". On the left is a vertical sidebar with six steps: 1. Select an OVF template (highlighted), 2. Select a name and folder, 3. Select a compute resource, 4. Review details, 5. Select storage, and 6. Ready to complete. The main area is titled "Select an OVF template" and contains the following text: "Select an OVF template from remote URL or local file system. Enter a URL to download and install the OVF package from the Internet, or browse to a location accessible from your computer, such as a local hard drive, a network share, or a CD/DVD drive." Below this text are two radio buttons: "URL" (unselected) and "Local file" (selected). Under the "URL" option is a text input field containing "http | https://remoteserver-address/filetodeploy.ovf | .ova". Under the "Local file" option is a button labeled "UPLOAD FILES" followed by the text "cognex-station-manager-1.0.0+31.16ea7af-vmware.ova". At the bottom right of the main area are two buttons: "CANCEL" and "NEXT".

3. Click **Next**.
4. Provide a name for the virtual machine that is created from the OVF template.

5. Select the inventory location for the virtual machine.

Deploy OVF Template

- 1 Select an OVF template
- 2 Select a name and folder**
- 3 Select a compute resource
- 4 Review details
- 5 Select storage
- 6 Ready to complete

Select a name and folder ×

Specify a unique name and target location

Virtual machine name:

Select a location for the virtual machine.

- vbvcenter.pc.cognex.com
 - US
 - HQ-dHCI
 - Edge-Intelligence-OVAs**

CANCEL BACK NEXT

6. Click **Next**.
7. Choose the host, cluster, resource pool, or vApp where the virtual machine runs.

8. Select the appropriate compute resource for your deployment.

Deploy OVF Template

- Select an OVF template
- Select a name and folder
- Select a compute resource**
- Review details
- Select storage
- Ready to complete

Select a compute resource

Select the destination compute resource for this operation

- HO-dHCI
 - DHCI-General Cluster
 - Edge-Intelligence-Resource-Pool**

Compatibility

✓ Compatibility checks succeeded.

CANCEL BACK **NEXT**

9. Click **Next**.

- Verify the template details including the publisher, download size, and description. Confirm these are correct for the Edge Intelligence Station Manager OVA.

The screenshot shows a 'Deploy OVF Template' wizard window. On the left, a vertical list of steps is shown, with '7 Ready to complete' highlighted in a dark blue bar. The main area of the window is titled 'Ready to complete' and contains a summary of the selected configuration options. At the bottom right, there are three buttons: 'CANCEL', 'BACK', and 'FINISH'.

Section	Property	Value
Select a name and folder	Name	Station Manager - v1
	Template name	cognex-station-manager-1.0.0+31.16ea7af-vmware
	Folder	Edge-Intelligence-OVAs
Select a compute resource	Resource	Edge-Intelligence-Resource-Pool
Review details	Download size	8.4 GB
Select storage	Size on disk	170.0 GB
	Storage mapping	1
	All disks	Datastore: Natick-DS2-GC-OVA; Format: Thick provision lazy zeroed
Select networks	Network mapping	1
Bridged	engineering	
	IP allocation settings	
IP protocol	IPV4	
IP allocation	Static - Manual	

- Click **Next**.
- Choose the destination storage or storage cluster for the virtual machine configuration and disk files.

13. Optionally select the virtual disk format as **Thick Provision Lazy Zeroed** and **VM Storage Policy**.

Deploy OVF Template

- 1 Select an OVF template
- 2 Select a name and folder
- 3 Select a compute resource
- 4 Review details
- 5 Select storage**
- 6 Select networks
- 7 Ready to complete

Select storage

Select the storage for the configuration and disk files

Select virtual disk format: Thick Provision Lazy Zeroed

VM Storage Policy: Thick Provision Lazy Zeroed

Disable Storage DRS for this storage

Name	Storage Compatibility	Capacity	Provisioned	Free	Type	Cluster
Natick-DS2-GC-O...	--	1.5 TB	244.86 GB	1.26 TB	VMFS 6	

1 item

Compatibility

Select a valid destination storage.

CANCEL BACK NEXT

14. Click **Next**.

15. Select the relevant network.

Deploy OVF Template

- Select an OVF template
- Select a name and folder
- Select a compute resource
- Review details
- Select storage
- Select networks**
- Ready to complete

Select networks

Select a destination network for each source network.

Source Network	Destination Network
Bridged	engineering ▾

1 item

IP Allocation Settings

IP allocation: Static - Manual

IP protocol: IPv4

CANCEL BACK NEXT

16. Click **Next**.

17. Review the details and configuration selected in the previous steps.

The screenshot shows a wizard window titled 'Deploy OVF Template' with a sidebar on the left and a main content area on the right. The sidebar lists seven steps, with the seventh step, 'Ready to complete', highlighted in a dark blue bar. The main content area is titled 'Ready to complete' and contains a summary of the selected configuration. At the bottom right, there are three buttons: 'CANCEL', 'BACK', and 'FINISH'.

Deploy OVF Template

- 1 Select an OVF template
- 2 Select a name and folder
- 3 Select a compute resource
- 4 Review details
- 5 Select storage
- 6 Select networks
- 7 Ready to complete**

Ready to complete ✕

Review your selections before finishing the wizard

- ▼ **Select a name and folder**
 - Name Station Manager - v1
 - Template name cognex-station-manager-1.0.0+31.16ea7af-vmware
 - Folder Edge-Intelligence-OVAs
- ▼ **Select a compute resource**
 - Resource Edge-Intelligence-Resource-Pool
- ▼ **Review details**
 - Download size 8.4 GB
- ▼ **Select storage**
 - Size on disk 170.0 GB
 - Storage mapping 1
 - All disks Datastore: Natick-DS2-GC-OVA; Format: Thick provision lazy zeroed
- ▼ **Select networks**
 - Network mapping 1
 - Bridged engineering
 - IP allocation settings
 - IP protocol IPV4
 - IP allocation Static - Manual

CANCEL BACK FINISH

18. Click **Finish** to initiate the OVA deployment task.

19. The OVA is now downloaded (if specified by URL) or uploaded from your local file and deployed to the selected compute resource and storage. You can see the progress at the bottom in the Status Window.

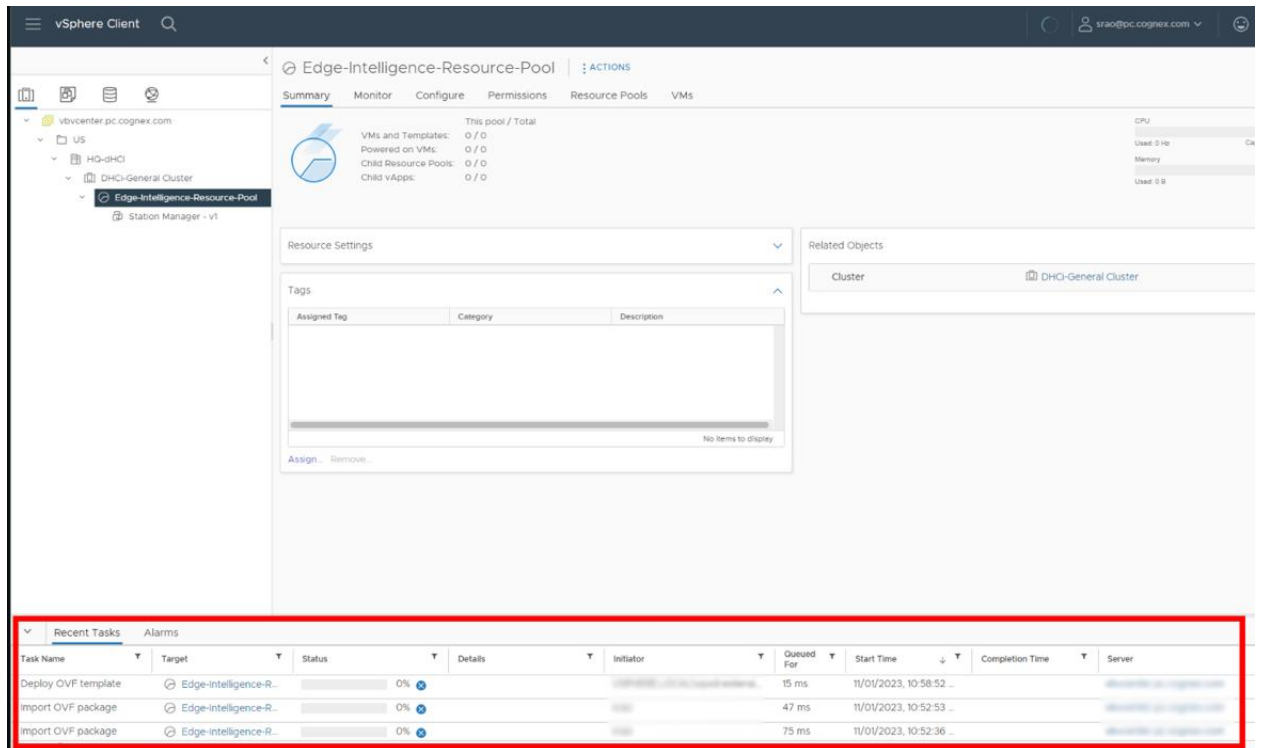

20. After the deployment finishes, the EI Station Manager virtual machine is created and ready for configuration and use. Enter the IP address specified to access EI Station Manager with a browser.

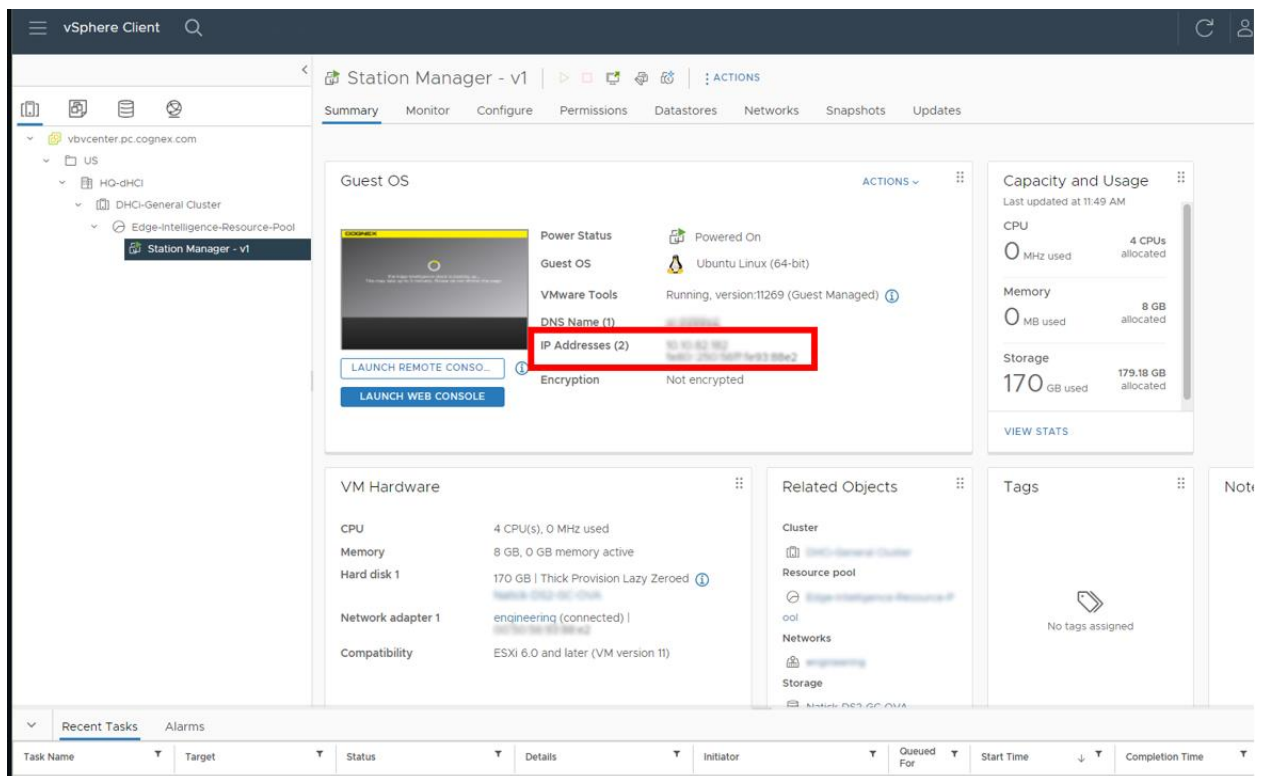

Discovering Devices on the Network

The default IP address for the Internal Ethernet port of EI Station Manager is set to 192.168.1.100. All devices on the network are discovered automatically, regardless of the network settings. However, discovered devices are labeled as misconfigured if they are not in the local subnet.

Discover Devices

Upon successfully logging in, the web UI launches, and EI Station Manager auto-discovers the devices on your network, which appear listed on your home screen.

Click on the **Discover Devices** button in the header of the web interface to force a rediscovery if you have connected a new device after the initial auto-discovery.

Note:

If you need to change the network settings of your EI Station Manager, open the menu and go to the Settings > Edge Device. From there, you can set the network settings.



Network Configuration

Device Name:

Network Interface: eth3

Enable DHCP

IP Address:

Subnet Mask:

Gateway:

DNS Server:

Network Settings

It is recommended that all Cognex devices be on the same network as EI Station Manager. In order to make this happen, change the IP address of all readers on the network to be in the same network as 192.168.1.xxx, or change the IP address of the Ethernet port to match those of the readers.



Note: The devices found on the network are listed on the first page of the Device Management Application.

Home » Device Management » DataMan



Add Selected To Group
Upload Configuration
Upload Firmware
Download As CSV
Discover Devices

Standalone Devices

	Actions	Password Protected	Primary	Name	Type	MAC Address	Firmware Version
<input checked="" type="checkbox"/>				DM250-T2P100-004	DeviceM250	00:00:0A:40:72:04	5.7.3_L49
<input type="checkbox"/>				DM250-254012	DeviceM250	00:00:0A:40:72:04	Development 5.7.3_L49 10.00 04/10/19
<input type="checkbox"/>				DM250-071004	DeviceM250	00:00:0A:40:72:04	5.7.3_L49_L49
<input type="checkbox"/>				DM270-000000	DeviceM270	00:00:0A:40:72:04	5.7.14_L47
<input type="checkbox"/>				DM270-01 Omega-Steerable_Mirror	DeviceM270	00:00:0A:40:72:04	5.7.14_L49

Remote Connection Troubleshooting

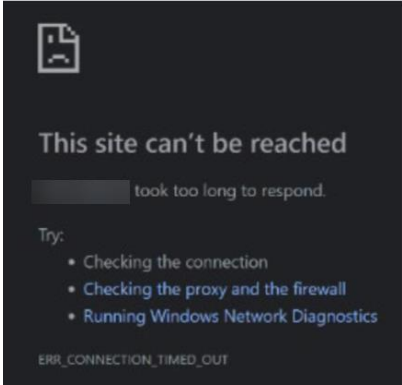
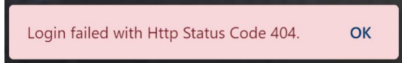
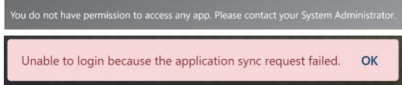
This section lists the most common errors and their solutions.

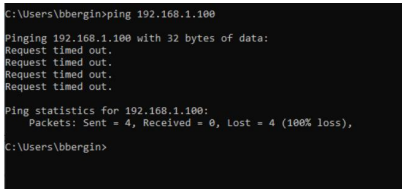
Error	Illustration	Solution
EI Station Manager is not visible in the Setup Tool or in the browser		Check wire connections and secure them if necessary.
Failed login error message		Check the credentials and reenter username and/or password.
Component load error message		Reboot device and wait for services to start.
No data/images available		Check device availability and setup.
Cannot access EI Station Manager URL		Check that subnets do not overlap. The network administrator must ensure that the IPs do not overlap.

Note: For the best results, use Ethernet connection to your network, because Wi-Fi might not allow the connection depending on your network settings.

Note: The login page lists the IP address of your devices.



About EI-DemoUnit

Documentation

[Click here to open documentation.](#)

Network Interfaces

Name	Operational	MAC Address	Address Type	IP Address	Subnet Mask	Gateway	DNS Server	Domain
	✓		DHCP					(none)
	✓		DHCP					(none)
	✓		Static					(none)

EI Station Manager User Interface

The EI Station Manager user interface provides the following applications:

- Performance Analytics
- Events
- Reporting
- Provisioning
- Device Management
- Archiver
- Settings
- User Management
- Single Sign-On
- Cloud Forwarding
- Data Transfer
- Notification Center
- Licensing

Click the app icon in the upper left corner of the page to open the navigation pane. Use the tree to navigate between the available apps and their pages:

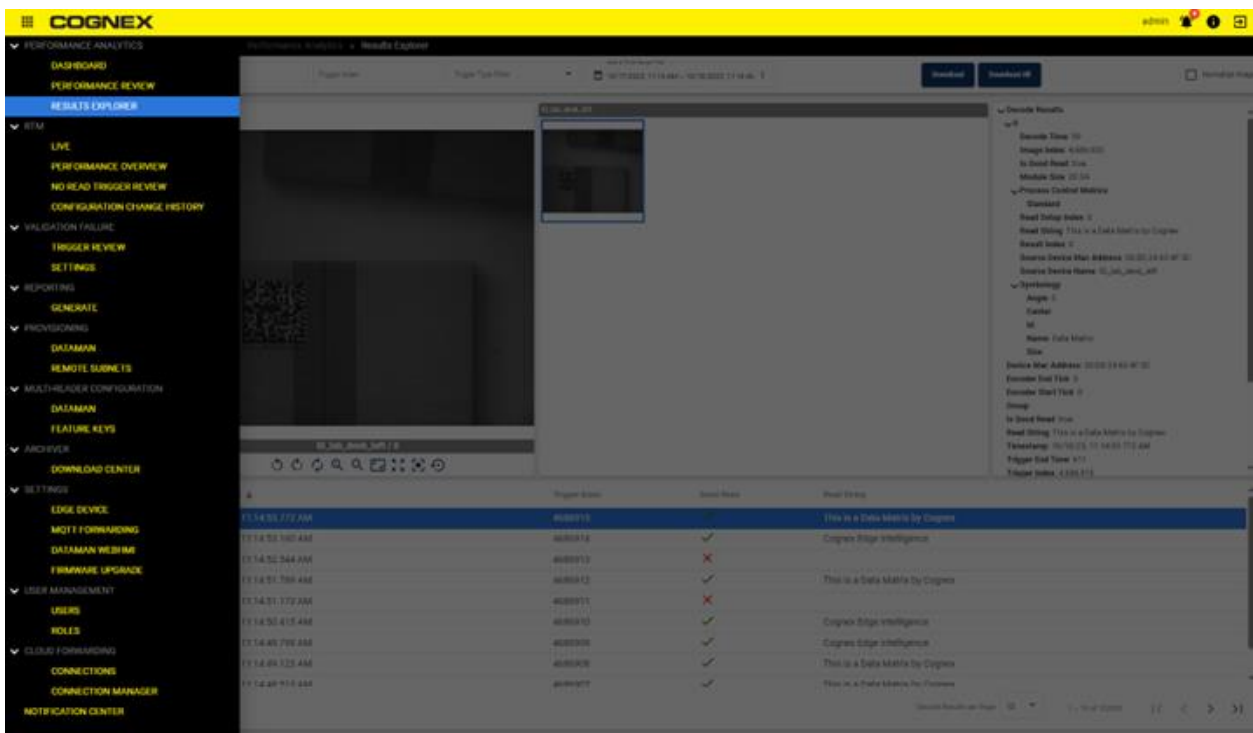

Ribbon Elements

The yellow top ribbon appears on all pages, and provides the following features:

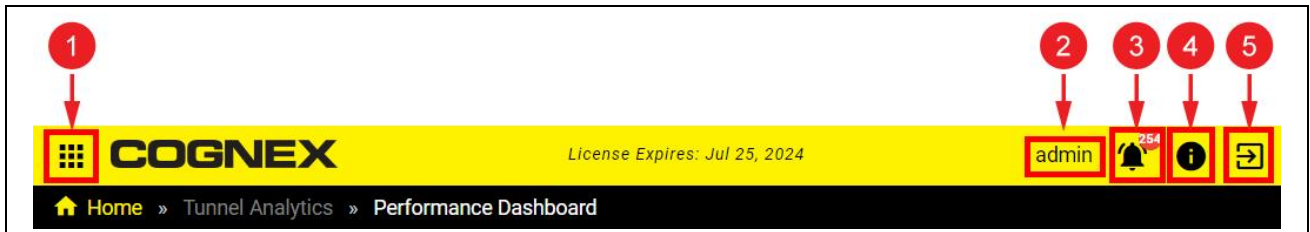

Number	Element	Description
1	App Menu	Click on the Menu icon in the upper left corner to open the navigation pane. Use the tree to navigate between the available apps and their pages.
2	User	The ribbon displays the user that is signed in.
3	Notifications	Click on the Bell icon in the upper right corner to view the notifications. Click on a notification to open it in the Notification Center on page 75 .
4	About	Click on the Info icon to open the About Pop-Up on page 1 .
5	Logout	Click on the Logout icon to log out.

Performance Analytics

The Performance Analytics application of the EI Station Manager user interface provides analytics options.

Dashboard

The **Dashboard** page of the Performance Analytics application provides a configurable set of saved charts that visualize the performance data of connected devices. The Dashboard allows you to create and save new charts, and edit existing ones, with multiple chart type display options and a wide array of data sets. You can also set the date and time range, and the charts on the Dashboard update accordingly.

The **Dashboard** page:

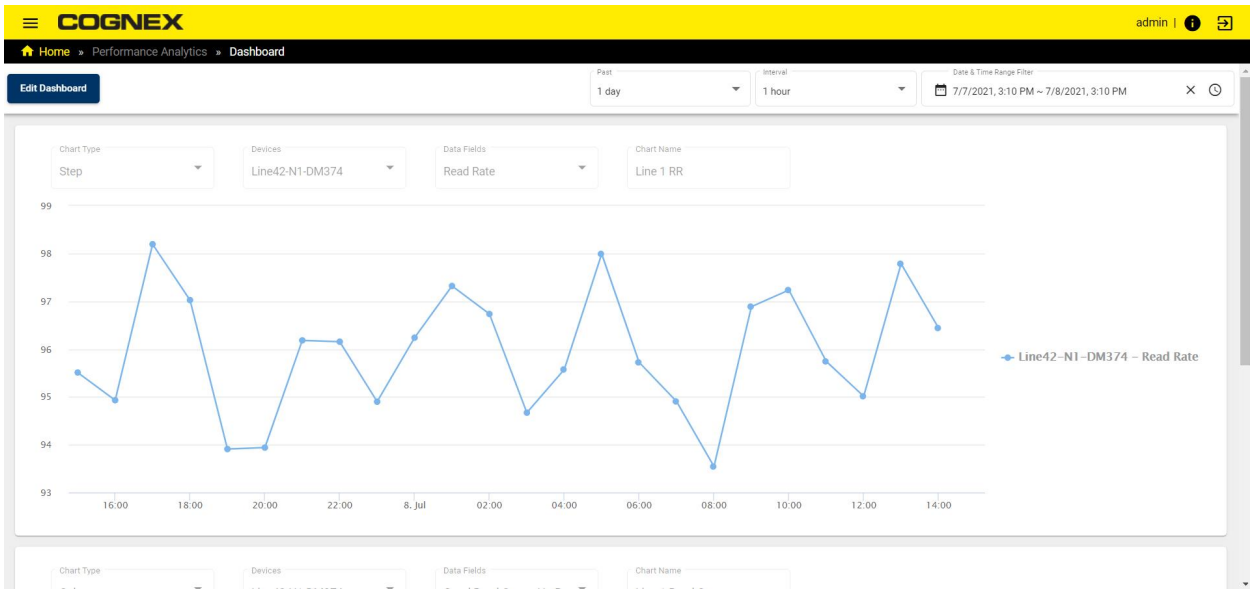

Edit Dashboard

Click **Edit Dashboard** in the top left corner of the page to enable creating, editing, moving, and deleting charts on the Dashboard.

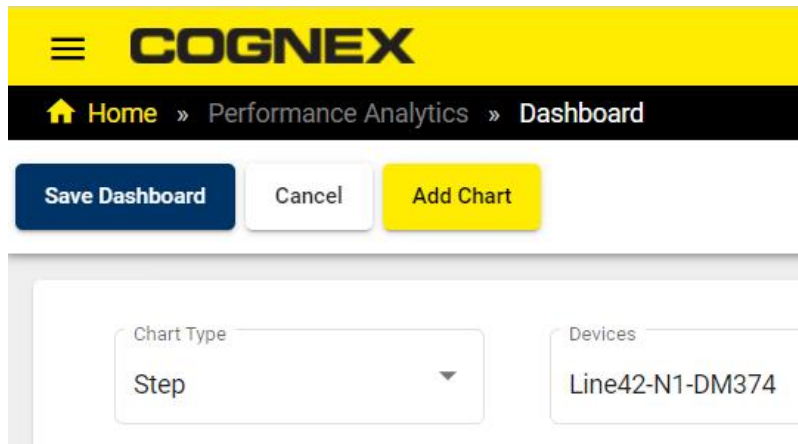

To create a new chart at the top of the Dashboard:

1. Click **Add Chart** to create an empty chart.
2. Set the **Chart Type** by clicking on the property box and selecting the desired settings from the dropdown. The following chart types are available:
 - Step
 - Line (default)
 - Column
 - Scatter
3. The **Devices** property provides a list of all connected devices. Check the checkbox of one or more devices to add their data to the chart.

4. Select one or more of the available **Data Fields**:

- Good Read Count
- No Read Count
- Read Rate
- Throughput
- Validation Rate
- Failed Validation Count
- Passed Validation Percent
- Missed Trigger Percent
- Buffer Overflow Count
- Trigger Overrun Count



5. Fill in the **Chart Name** text box to give the chart a name.

To edit an existing chart, click on its properties and change the settings. The chart updates automatically to reflect the new settings.

To move a chart up or down on the Dashboard, click on the arrow icons in the top right corner of the chart.

To delete a chart, click on the trash icon in the top right corner of the chart.

Once you are done editing the Dashboard, click **Save Dashboard** to save your changes, or **Cancel** to discard your changes.

You can zoom into areas of interest on the charts by clicking and dragging the cursor. Click **Reset Zoom** to return to the full time range.

Results Explorer

The **Results Explorer** page of the Performance Analytics application allows you to filter the results that Cognex devices collect and to find the data that is the most important to you. On the device tree, select the reader to use with Results Explorer.

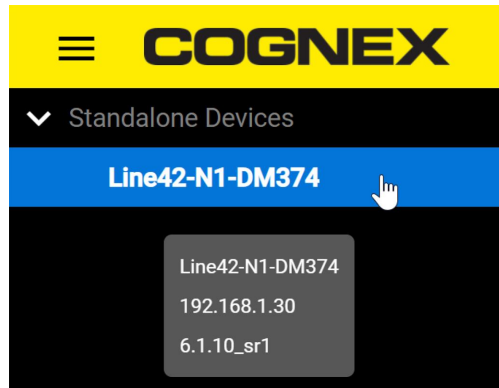

Double-clicking the selected device automatically brings you to the Results Explorer window, which provides a list of all trigger acquisitions on the reader and further information about each.

Date & Time	Trigger Index	Good Read	Read String
05/10/22, 11:10:23.788 AM	282761	✓	This is a Data Matrix by Cognex
05/10/22, 11:10:22.638 AM	282760	✓	This is a Data Matrix by Cognex
05/10/22, 11:10:21.488 AM	282759	✓	This is a Data Matrix by Cognex

To filter acquisition details for the selected device, fill in the entry fields on the top of the Results Explorer window:

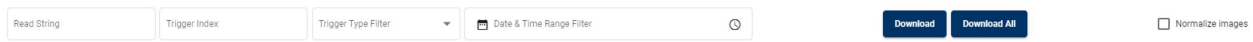

- In the **Read string** entry field, look over the triggers that contain a specific character string.
- In the **Trigger Index** entry field, filter trigger acquisitions by entering the number of the trigger Index.

- In the **Trigger Type Filter** dropdown menu, choose from the following options:
 - Good Read
 - No Read
 - Validation Failure

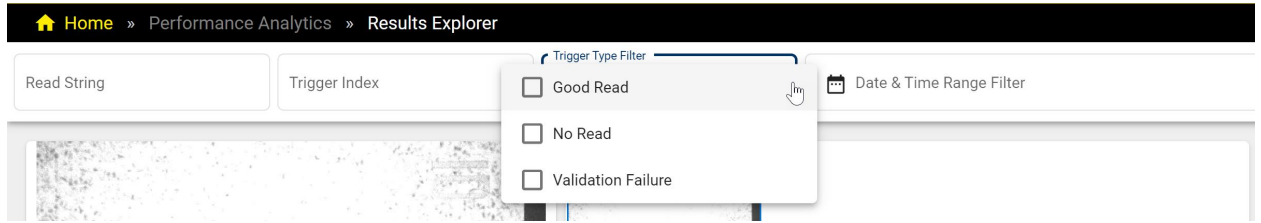

- In the **Date & Time Range Filter**, specify the time range of the results. For more information, see *Date & Time Range Filter on page 1*
- With the **Download** button, download the captured images to your computer.
- With the **Download All** button, start a bulk download of images, triggers, or both. The bulk download operation stores an archive of the selected images and triggers on the EI Station Manager. When you click on the **Download All** button, the **Download Data** pop-up window appears.

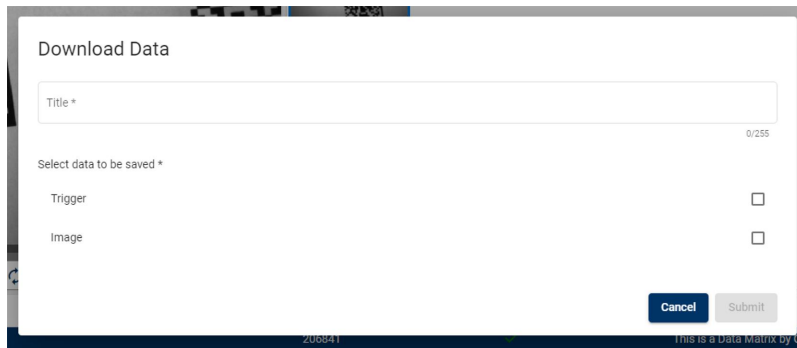

To provide the name of your archive, fill in the **Title** textbox. To select images, triggers, or both, check the **Trigger** and **Image** checkboxes. To download your archive, click on the **Submit** button. To exit from the window, click on the **Cancel** button.

- With the **Normalize images** checkbox, increase image contrast. To set the images back to default, uncheck the checkbox .



You can change the view of the selected image in the image pane with the Device Display Controls.

In the sidebar on the right, you can see more in-depth decode results for each of the trigger acquisitions on the list.

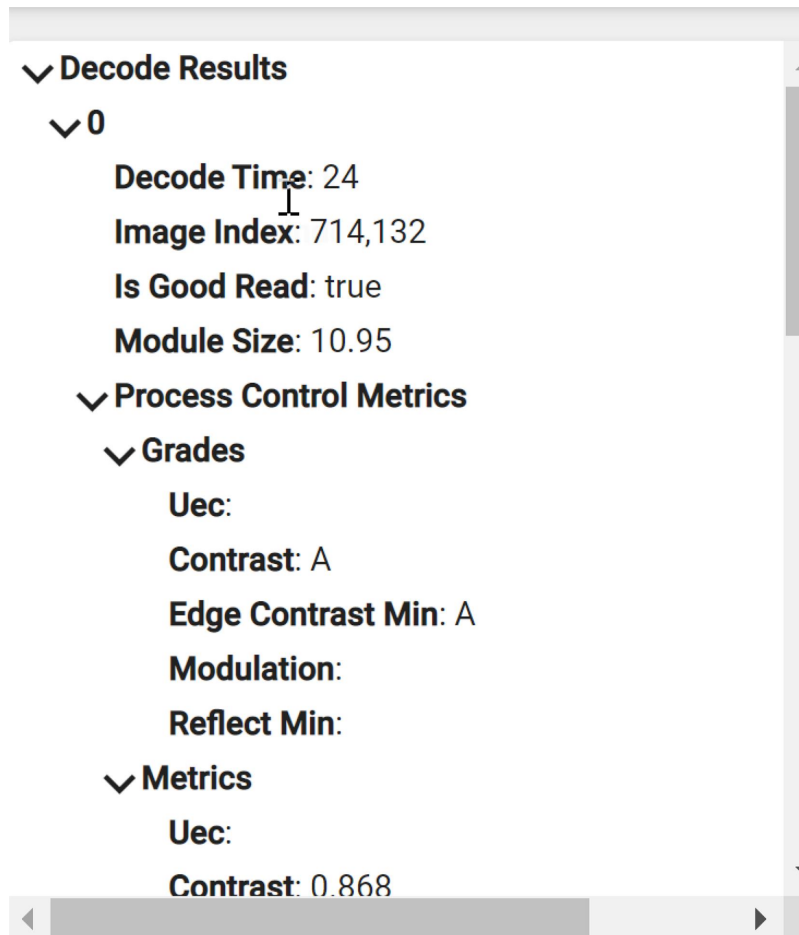

Events

The Events app contains the Configuration Change History page, which allows you to track changes to the connected EI Station Managers.

Configuration Change History

The Configuration Change History page tracks changes made to the configuration of all connected readers and shows changes in a customized fashion. The window displays the Device tree with available grouped and standalone readers. The page automatically links configurations with the respective usernames.

The screenshot shows the 'Configuration Change History' page in the COGNEX El Station Manager. The interface includes a top navigation bar with the COGNEX logo and user information. A left sidebar provides navigation for 'All' and 'Standalone Devices', with 'DM374-El-Demo-Online' selected. The main content area features a 'Compare Configurations' button and a date range filter set to '4/8/2020, 2:58 PM - 4/9/2020, 2:58 PM'. Below this is a table listing configuration changes:

Actions	Date & Time ↓	Device Name	Username
<input type="checkbox"/>	4/9/20, 7:05 AM	DM374-El-Demo-Online	admin
<input type="checkbox"/>	4/9/20, 7:03 AM	DM374-El-Demo-Online	admin
<input type="checkbox"/>	4/9/20, 5:06 AM	DM374-El-Demo-Online	admin
<input type="checkbox"/>	4/9/20, 5:04 AM	DM374-El-Demo-Online	admin
<input type="checkbox"/>	4/9/20, 3:06 AM	DM374-El-Demo-Online	admin
<input type="checkbox"/>	4/9/20, 3:04 AM	DM374-El-Demo-Online	admin
<input type="checkbox"/>	4/9/20, 1:06 AM	DM374-El-Demo-Online	admin
<input type="checkbox"/>	4/9/20, 1:04 AM	DM374-El-Demo-Online	admin
<input type="checkbox"/>	4/8/20, 11:06 PM	DM374-El-Demo-Online	admin
<input type="checkbox"/>	4/8/20, 11:04 PM	DM374-El-Demo-Online	admin

At the bottom right of the table, there is a pagination control showing 'Items per page: 10' and '1 - 10 of 24'.

Configuration Change Actions

Icon	Action
	Selected checkbox
	Download Configuration File
	Restore Configuration

- Click the **checkbox** from the list in the left side of the rows to select a configuration.
- Click the **Download Configuration File** to download the selected Configuration files.

- Click **Restore Configuration** to revert to a previous configuration.
 - After clicking **Restore Configuration** enter your password and click **Restore** to revert configuration. Click **Cancel** to leave the popup window without restoring the selected configuration.

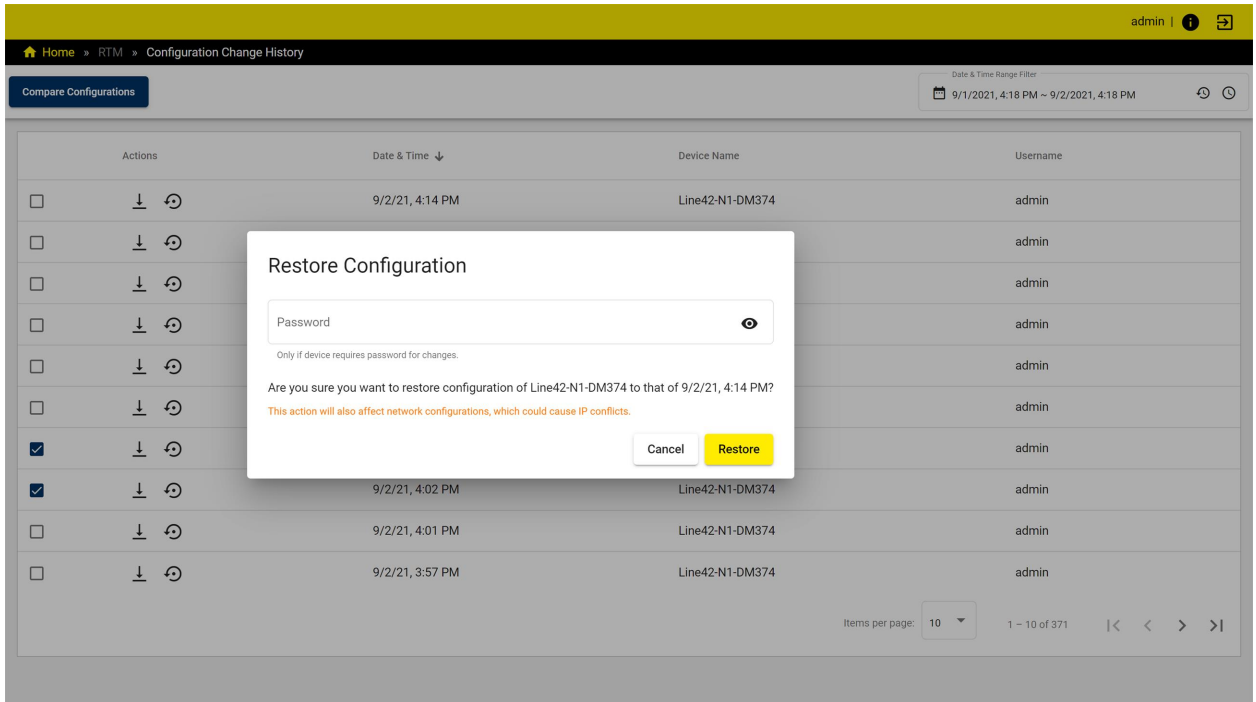

Dashboard overview:

Item	Description
Compare Configurations button	Select 2 checkbox to enable the button. Click the button to see configuration changes in a pop-up window. For more information see
Date & Time Range Filter	Use the time range to define a period of time from which performance data is collected for the charts. For more information see Date & Time Range Filter on page 1
Configuration tables	List of readers and groups available for comparison.

Note: Changes made from Dataman Setup Tool are labeled as admin changes.

Column Name	Description	Display
Date and time	Date and time of the configuration change.	3/3/20, 9:10 AM
Device name	Name of the reader on the network.	
Username	Name and type of the user who made the configuration change.	

Configuration Changes

To compare two configurations, select the readers to compare. Click on the Compare Configurations button. A pop up window appears with a table containing the comparison results.

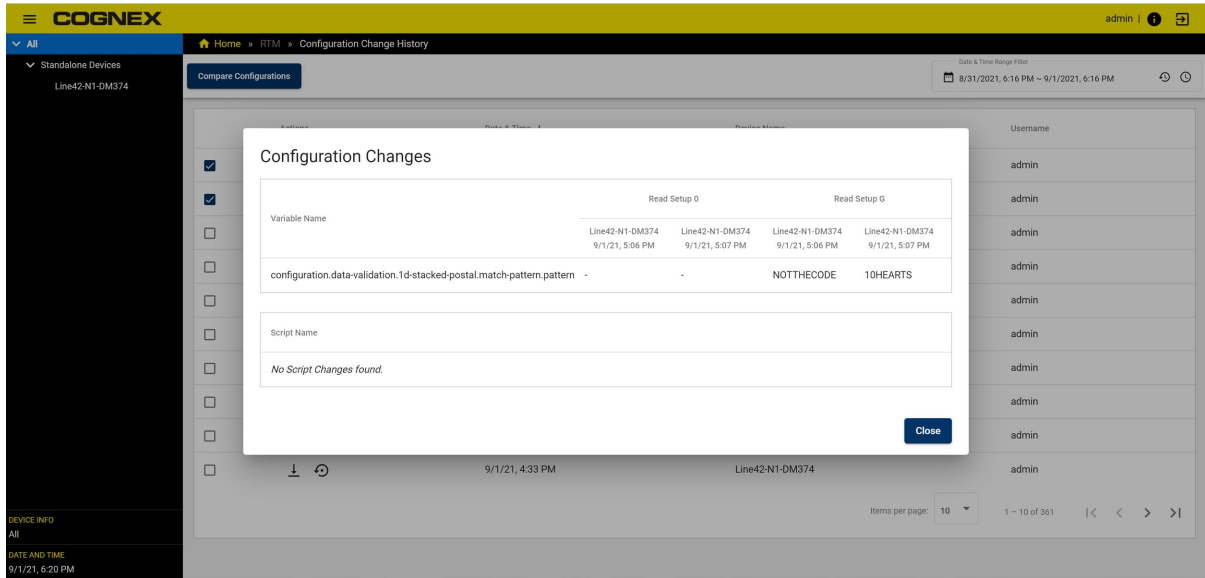

Item	Description
Configuration Changes	Lists variables which have different values in the compared versions
Variable Name	Name of the variable which has different values in the compared versions
Script Name	Name of the recently modified script
Read Setup	Name of the read setup

Variable changes:

Configuration Changes

Read Setup 0		
Variable Name		
	DM374-EI-Demo-Online 4/9/20, 7:03 AM	DM374-EI-Demo-Online 4/9/20, 7:05 AM
configuration.imager.gain-factor	15.00	5.00

Script Name
<i>No Script Changes found.</i>

Close

Column Name	Description
Variable Name	List of variables that have different values in the compared configuration versions
Read Setups	Display the name of the readers compared, and the difference in values pertaining to the row of the configuration scripts

Script changes:

Configuration Changes

Variable Name
<i>No Variable Changes found.</i>

Script Name	DM474-628156 4/15/20, 1:02 PM	DM474-628156 4/15/20, 2:08 PM
communication.script	<pre>// Comms script that triggers the reader twice/second var timerHandler = null; var trigger_delay = 0.5; // trigger twice/second function CommHandler() { return { onConnect: function (peerName) { // Disable the handler for this connection: if (peerName.indexOf("COM") >= 0) { timerHandler = this; timerHandler.setTimer(trigger_delay); return true; } return false; }, onDisconnect: function () {}, onError: function (errorMsg) {}, onExpectedData: function (inputString) { return true; }, onUnexpectedData: function (inputString) { return true; }, onTimer: function () { dmccCommand("TRIGGER", "ON"); if (timerHandler != null) timerHandler.setTimer(trigger_delay); }, onEncoder: function () {} }; }</pre>	<pre>// Comms script that triggers the reader twice/second function CommHandler() { return { onConnect: function (peerName) { // Disable the handler for this connection: return false; }, onDisconnect: function () {}, onError: function (errorMsg) {}, onExpectedData: function (inputString) { return true; }, onUnexpectedData: function (inputString) { return true; }, onTimer: function () {}, onEncoder: function () {} }; }</pre>
format.script	<pre>// Default script for data formatting function onResult (decodeResults, readerProperties, output) { if (decodeResults[0].decoded) { output.content = decodeResults[0].content; }</pre>	<pre>// Default script for data formatting function onResult (decodeResults, readerProperties, output) { if (decodeResults[0].decoded) { output.content = decodeResults[0].content; } else { output.content = "Not able to decode candidates"; }</pre>

Close

Column Name	Description
Variable Name	List of variables that have different values in the compared configuration versions
Read Setups	Display the name of the readers compared, and the difference in values pertaining to the row of the configuration scripts

Reporting

The Reporting application contains the Generate page which allows you to generate reports.

Generate

The Generate page of the Reporting application allows you to create new reports and manage existing ones.

Home > Reporting > Generate

Refresh Delete selected

Generate new report

Title * demo File Name
Eg: Cognex1_Report 0/30

Template * Customer Name

Site Name Scan Point Name

Reporting Range * [calendar icon] [x] [refresh icon] [refresh icon]

Reset Generate

Actions	Title	Scan Point Name	Site Name	Customer Name	Username	Request Date & Time	From Date & Time	To Date & Time	Template	File Name	Autogenerated
<input type="checkbox"/> [edit icon] [download icon] [delete icon] [refresh icon]	Test_repo			Ayshan Yariyeva	Unknown	8/5/21, 1:06 PM	8/4/21, 1:04 PM	8/5/21, 1:04 PM	Daily	test_report	
<input type="checkbox"/> [edit icon] [download icon] [delete icon] [refresh icon]	Test				Unknown	7/29/21, 10:23 PM	7/27/21, 10:23 PM	7/29/21, 10:23 PM	Daily		
<input type="checkbox"/> [edit icon] [download icon] [delete icon] [refresh icon]	L42N1	N1	L42	Cognex	Unknown	6/30/21, 8:14 PM	6/29/21, 6:00 PM	6/30/21, 6:00 PM	Daily	Report	

Items per page: 10 1 - 3 of 3 < > >|

To generate a new report, fill in the fields under the **Generate new report**. Click on the **Generate** button on the bottom right of the section to generate the report. You can find your generated report in the list on the bottom of the Generate page.

When you fill in the necessary fields, you are provided with a Template preview of the report. Click **Generate** again to create the report.

The Template field on the Generate page has a drop down bar which has two options: Daily and Weekly.

Template Preview: Daily

The Daily Report summarizes the performance of all your DataMan assets. The report contains a table outlining the performance statistics, a multi-line chart comparing the read rate data of each asset over time, and a stacked bar chart to view the hourly throughput for each asset. This template was designed to ideally summarize a day of asset performance containing data points captured with a granularity of 1 hour. It is recommended you select a reporting range of around 24 hours.

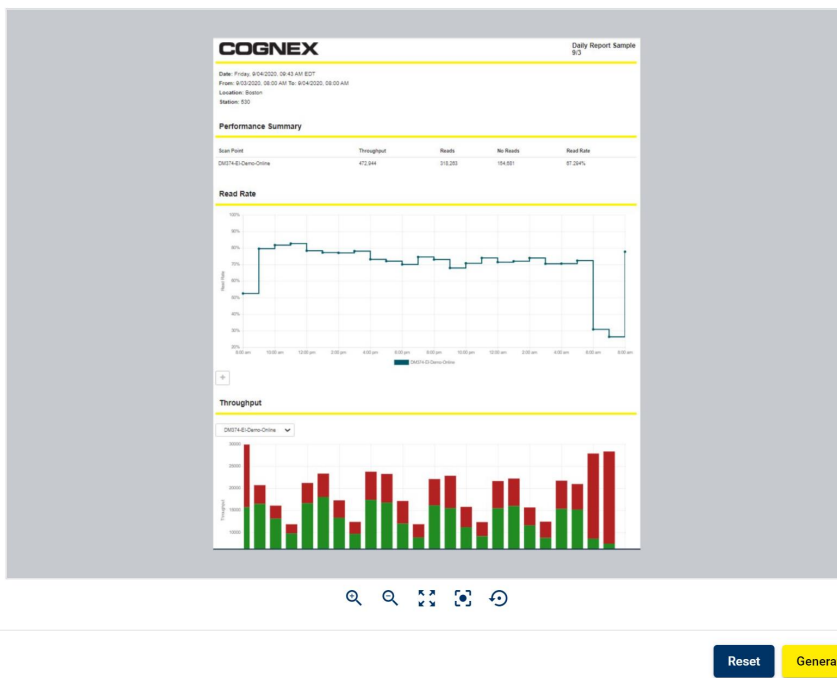

Template Preview: Weekly

The Weekly Report summarizes the performance of all your DataMan assets. The report contains a table for each asset with the performance statistics summarized for each day included in your reporting range. This template was designed to ideally summarize a week of asset performance containing data points captured with a granularity of 1 day. It is recommended you select a reporting range of around 7 days.

COGNEX					Weekly Report Sample 9/4
Date: Friday, 9/04/2020, 09:47 AM EDT					
From: 8/28/2020, 08:00 AM To: 9/04/2020, 08:00 AM					
Location: Boston					
Station: 530					
DM374-EI-Demo-Online					
Date	Throughput	Reads	No Reads	Read Rate	
8/27/2020	44,507	0	44,507	0.000%	
8/28/2020	124,570	0	124,570	0.000%	
8/29/2020	135,788	0	135,788	0.000%	
8/30/2020	719,122	579,574	139,548	80.595%	
8/31/2020	1,498,149	1,240,128	228,021	84.499%	
9/1/2020	1,241,151	1,078,366	162,785	86.884%	
9/2/2020	478,074	386,033	92,041	80.748%	
9/3/2020	244,080	150,422	93,658	61.628%	
DM474-EI-Demo					
Date	Throughput	Reads	No Reads	Read Rate	
8/27/2020	44,507	0	44,507	0.000%	
8/28/2020	124,570	0	124,570	0.000%	
8/29/2020	135,788	0	135,788	0.000%	
8/30/2020	719,122	579,574	139,548	80.595%	
8/31/2020	1,498,149	1,240,128	228,021	84.499%	
9/1/2020	1,241,151	1,078,366	162,785	86.884%	
9/2/2020	478,074	386,033	92,041	80.748%	
9/3/2020	244,080	150,422	93,658	61.628%	

To reset the fields in the **Generate new report** section, click on the **Reset** button.

The list at the bottom of the page lists the existing reports and their properties. To open, download, delete, or duplicate existing reports, use the icons in the **Actions** column of the list.

Individual Report Actions

You can perform actions on an individual report by clicking on the icons in the **Actions** column for the selected report:

<input type="checkbox"/> Actions	
<div style="border: 1px solid #ccc; padding: 5px; display: flex; gap: 10px;"> <input type="checkbox"/> <input type="checkbox"/> <input type="checkbox"/> <input type="checkbox"/> <input type="checkbox"/> </div>	
Icon	Action
	Open
	Download
	Bin
	Duplicate

- To open a report, click on **Open** next to the checkbox in the **Actions** column.
- To download a report, click on **Download**.

- To delete a report, check the checkbox on the left of the report you want to delete, and click on red **Bin**.
- To copy data from a previously created report into the form, click on **Duplicate**.

Provisioning

The Provisioning application of the EI Station Manager user interface allows you to provision your connected devices and device groups, configure what data to collect from your devices, and manage your remote subnets.

DataMan

The DataMan page of the Provisioning application provides a list of standalone devices, as well as device groups, and allows you configure what data you want to collect from each of your devices. You can also provision one or more of your devices at the same time, or individually by IP address.

The DataMan page:

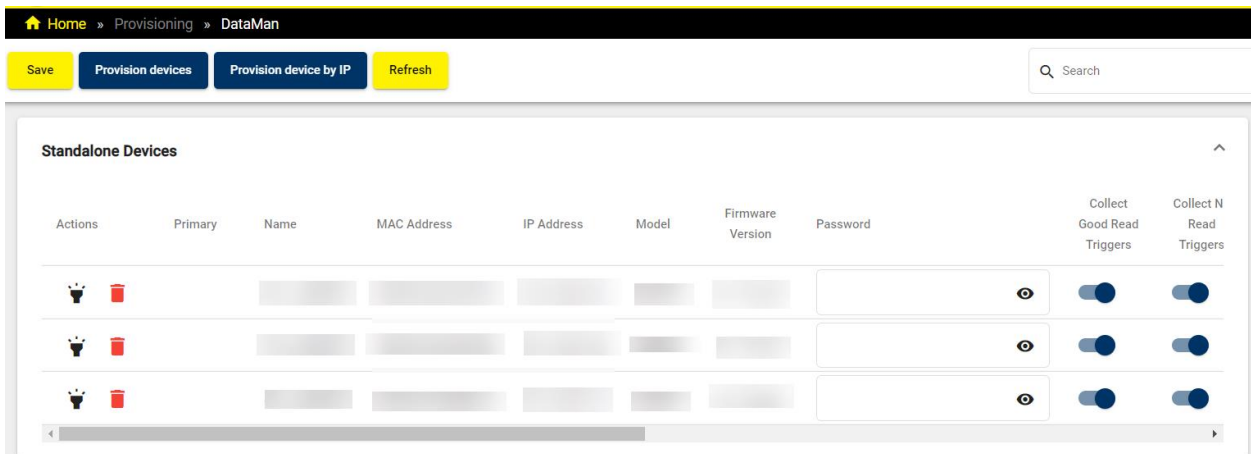

To refresh the list of connected devices, click **Refresh** in the header.

To provision devices, click **Provision devices** and use the pop-up dialog to select the devices. To provision a device by IP address, click **Provision device by IP** and enter the device IP address.

Click **Save** to apply any changes you make to device data collection settings.

Device Actions

You can perform actions on an individual device by clicking on the icons in the **Actions** column of the row for the selected device:

Actions	
Icon	Action
	Flash LED
	Delete

- Click the **Flash LED** button to remotely trigger the LED of the device for easy identification.
- Click the **Delete** button to remove the device from the list.

Provisioning Devices

Click on **Provision devices** in the header to open the **Provision devices** pop-up dialog:

Provision devices

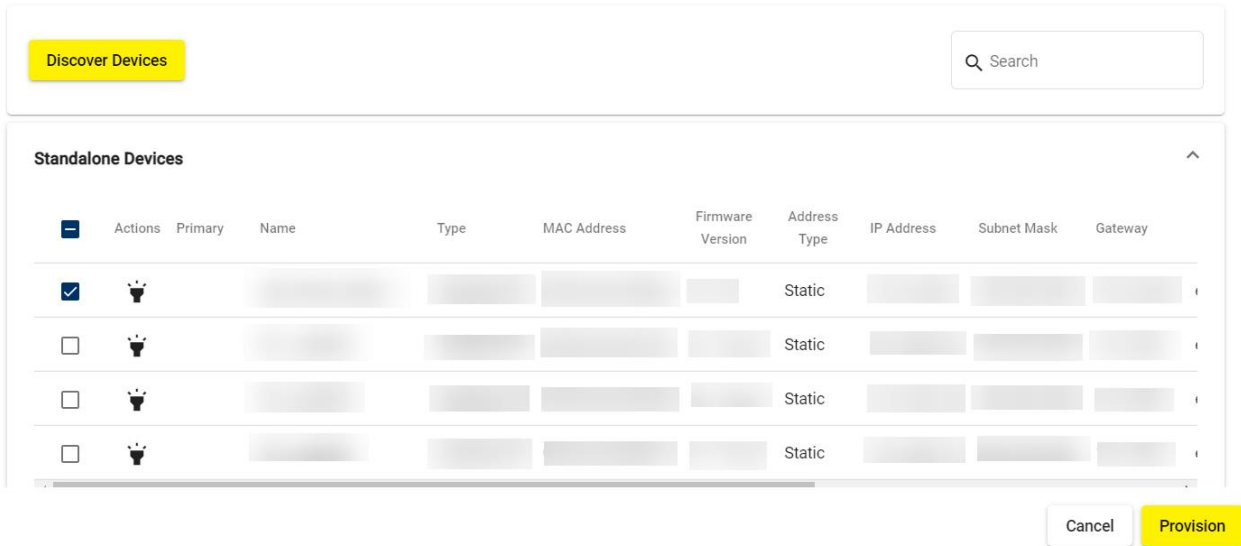

The **Provision devices** dialog provides a list of connected devices. To provision one or more devices, check the checkbox for the selected devices, and click **Provision**.

To flash the LED on a device for easier identification, click the **Flash LED** icon in the **Action** column of the row for the selected device.

To refresh the list of connected devices, click **Discover Devices**.

To search for a specific device in the list, enter the name or IP address in the **Search** bar.

Provision Device by IP

Click on **Provision device by IP** in the header to open the **Provision device by IP** pop-up dialog:

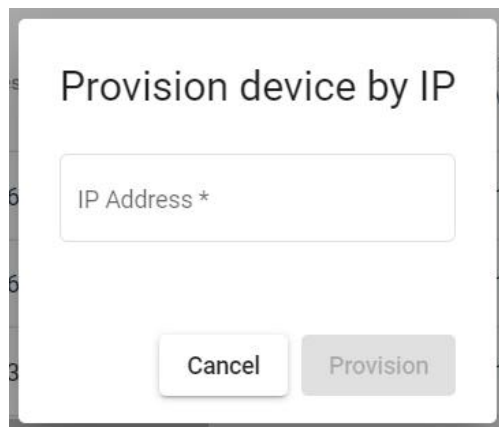

Enter the IP address of the selected device, and click **Provision**.

Data Collection Settings

You can modify collection settings for different types of device data by switching the toggles on or off in each data collection column of the row for the selected device:

Password		Collect Good Read Triggers	Collect No Read Triggers	Collect Validation Failure Triggers	Collect Good Read Images	Collect No Read Images	Collect Validation Failure Images	Collect Device Configuration Changes	Collect Statistics
<input type="text"/>		<input checked="" type="checkbox"/>	<input checked="" type="checkbox"/>	<input type="checkbox"/>	<input checked="" type="checkbox"/>	<input checked="" type="checkbox"/>	<input type="checkbox"/>	<input checked="" type="checkbox"/>	<input checked="" type="checkbox"/>
<input type="text"/>		<input checked="" type="checkbox"/>	<input checked="" type="checkbox"/>	<input type="checkbox"/>	<input checked="" type="checkbox"/>	<input checked="" type="checkbox"/>	<input checked="" type="checkbox"/>	<input checked="" type="checkbox"/>	<input checked="" type="checkbox"/>
<input type="text"/>		<input checked="" type="checkbox"/>	<input checked="" type="checkbox"/>	<input type="checkbox"/>	<input checked="" type="checkbox"/>	<input checked="" type="checkbox"/>	<input checked="" type="checkbox"/>	<input checked="" type="checkbox"/>	<input checked="" type="checkbox"/>

Column	Description
Password	Provide the password for the device to make any changes.
Collect Good Read Triggers	Enable this setting to collect good read trigger data from the device.
Collect No Read Triggers	Enable this setting to collect no read trigger data from the device.
Collect Validation Failure Triggers	Enable this setting to collect validation failure trigger data from the device.
Collect Good Read Images	Enable this setting to collect good read image data from the device. <div style="border: 1px solid gray; padding: 5px; margin-top: 10px;"> Note: When you enable good read image data collection, the device image format is set to 1/4 size JPEG. </div>
Collect No Read Images	Enable this setting to collect no read image data from the device.
Collect Validation Failure Images	Enable this setting to collect validation failure image data from the device.
Collect Image SVGs	Enable this setting to collect SVG images of barcode reads.
Collect Device Configuration Changes	Enable this setting to collect device configuration change data from the device.
Collect Statistics	Enable this setting to collect statistics from the device.

To order the list of devices by type of data collection enabled, click on a data collection column header.

Remote Subnets

The Remote Subnets page of the Provisioning application provides a list of remote subnets, and allows you to add additional subnets.

Actions	Name	IP Address	Subnet Mask	State
	[blurred]	[blurred]	[blurred]	Finished
	[blurred]	[blurred]	[blurred]	Finished

To remove a remote subnet from the list, click on the **Bin** icon in the **Actions** column of the row for the selected subnet.

Click on **Add Remote Subnet** to open the **Add Remote Subnet** pop-up dialog:

Add Remote Subnet

Enter the name, IP address, and subnet mask for the remote subnet you want to add, and then click **Add**.

Device Management

The Device Management application of the EI Station Manager user interface provides a list of standalone devices and device groups, shows device information, and allows you to modify settings on individual devices as well as multiple devices simultaneously. You can also save entire tables of device configuration data to your local machine.

DataMan

The DataMan page of the Device Management application provides a list of standalone devices, as well as device groups, including device data. You can edit the configuration, flash the LED, reboot, or access the DataMan WebHMI of individual devices from the DataMan page. You can perform mass configuration or firmware updates for device groups.

The DataMan page:

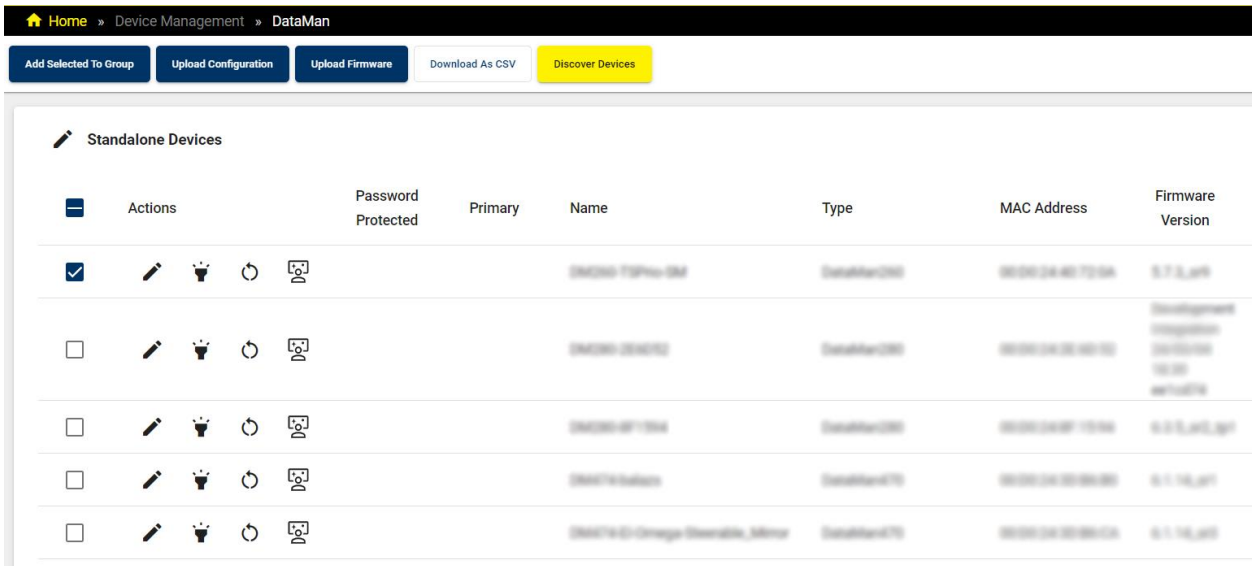

Item	Description
Action ribbon	Ribbon contains actions that can be performed on this page: <ul style="list-style-type: none"> • Add Selected to Group - Add selected devices to MRS group. • Upload Configuration - Upload a configuration file to selected devices. • Upload Firmware - Upgrade firmware on selected devices. • Download as CSV - Download a list of devices as a CSV file. • Discover devices - Trigger the app to find devices on the network.
Standalone reader list	A table view of the settings of the standalone readers that are discovered on the network with options that can be enabled or disabled for the reader.
Grouped reader list	Table views of the readers in a group sorted alphabetically by group name with options that can be enabled or disabled for the individual reader.
Search Field	Allows searching for a reader by Name, Model or Firmware version.





The table view of the standalone or group readers displays information and allows setting changes to the individual readers.

Column Title	Description
Actions	To flash the device LED, click on the Flash icon.
Password Protected	Indicates whether the device is password protected.
Primary	A check mark signifies the primary reader.
Name	A customizable name of the device.
Type	The model of the device.
MAC address	The MAC address of the device.
Firmware version	The version of firmware installed on the device.
Address type	Indicates network address type (DHCP or static) for the device.
IP address	The IP address of the device.

State	<p>Displays the state of the device, which can be:</p> <ul style="list-style-type: none"> • In Local Subnet • In Remote Subnet • In Remote Subnet Behind NAT • Waiting For DHCP • Misconfigured • Unknown
Task status	Displays the status of the task.

Individual Device Actions

You can perform actions on an individual device by clicking on the icons in the **Actions** column of the row for the selected device:

<p>Actions</p> <hr/>  <hr/>	
Icon	Action
	Single Device Edit
	Flash LED
	Reboot
	Open DataMan WebHMI

- Click the **Single Device Edit** button to modify the name, IP address, Subnet Mask, and Default Gateway of the device. Enter the device password if required.
- Click the **Flash LED** button to remotely trigger the LED of the device for easy identification.
- Click the **Reboot** button to initiate a reboot on the device.
- Click the **Open DataMan WebHMI** button to open the DataMan WebHMI in a new tab. For more information on the DataMan WebHMI, see [DataMan WebHMI on page 43](#).

Device Group Actions

To perform group actions, check the checkbox of the selected devices, enabling the group action buttons in the header:

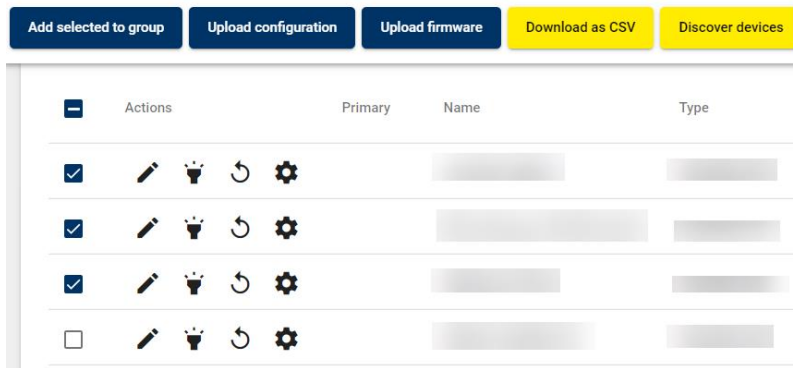

Click the **Add to selected group** button to open the **Multi Device Edit** window:

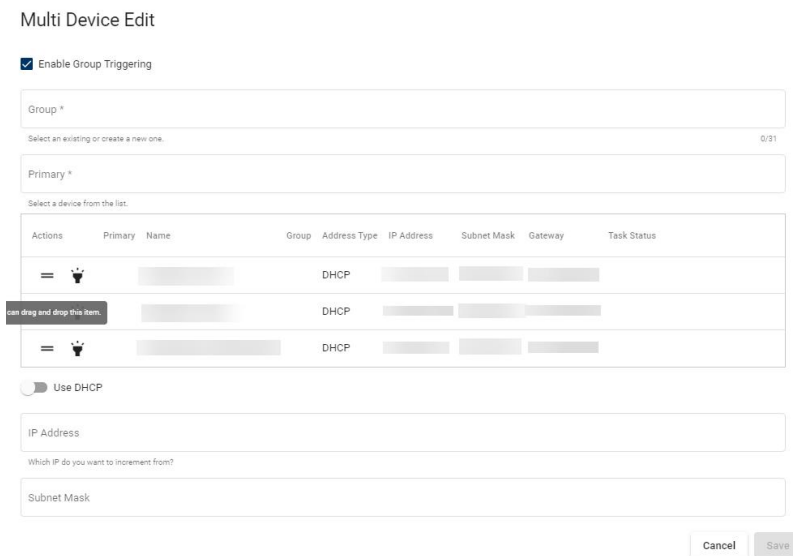

In the **Multi Device Edit** window, you can:

- add the selected devices to an existing group
- create a new group with the selected devices
- define a primary device in the group
- reorder the devices
- flash the LEDs of the individual devices for easy identification
- manually configure the IP Address, Subnet Mask, and Default Gateway

Enter the device password if the device is set up to require it. Click **Save** to apply any changes.

To upload a saved configuration file to selected devices, click the **Upload configuration** button, opening the **Upload configuration to selected devices** window:

Click **Browse** to select the configuration file for upload. Enable **Apply network settings** to apply network settings. Enter the device password if the device is set up to require it, and click **Upload**.

To update the firmware on selected devices, click the **Upload firmware** button, opening the **Upload firmware to selected devices** window:

Click **Browse** to select the firmware file for upload. Enable **Apply network settings** to apply network settings. Enter the device password if required, and click **Upload**.

DataMan WebHMI

The DataMan WebHMI application provides a live view of device reads, results and statistics, and allows you to pause the feed and scroll back to analyze or download individual result images. You can manually trigger or tune devices and adjust device settings from the DataMan WebHMI.

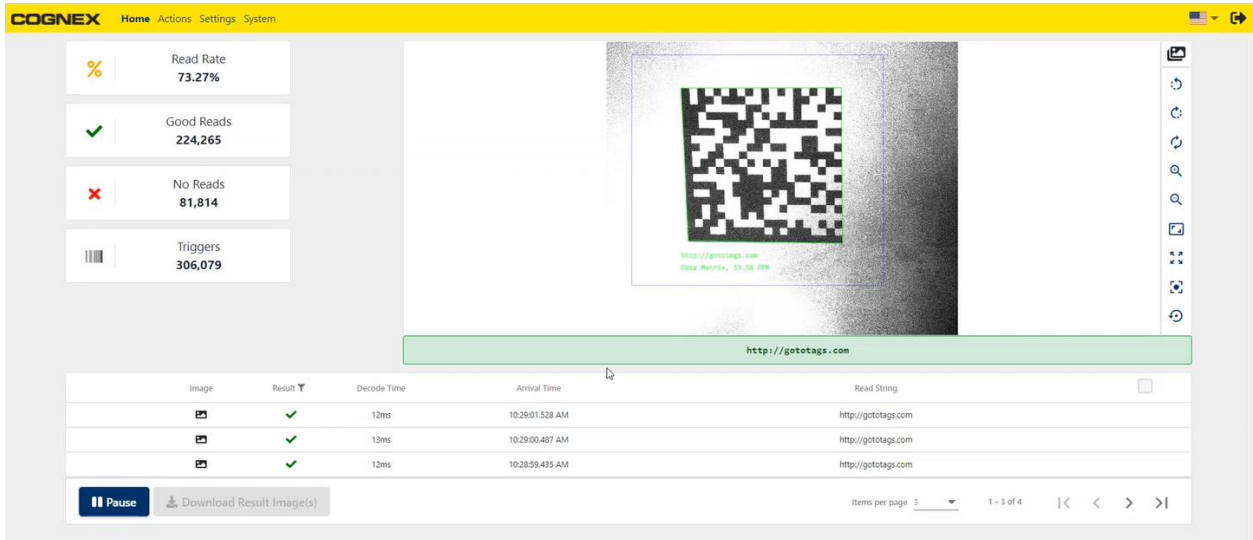

You can access the DataMan WebHMI for a connected DataMan device from the DataMan page of the EI Station Manager user interface by clicking on the gear icon labeled **Open DataMan WebHMI** in the **Actions** column of the selected device.

Home







The DataMan WebHMI **Home** page displays a live feed of the device with statistics and result logs.

On the left side, the DataMan WebHMI home page shows statistics for:

- **Read Rate** percentage
- Number of **Good Reads**
- Number of **No Reads**
- Number of **Triggers**

The display on the right side of the page provides a live feed of the device view with additional controls on the right side of the display for changing orientation and zoom:



Icon	Action
	Rotate Left 90°
	Rotate Right 90°
	Reset Rotation
	Zoom In

	
Icon	Action
	Zoom Out
	Zoom To Original Size
	Reset Zoom
	Move Center
	Reset All Settings

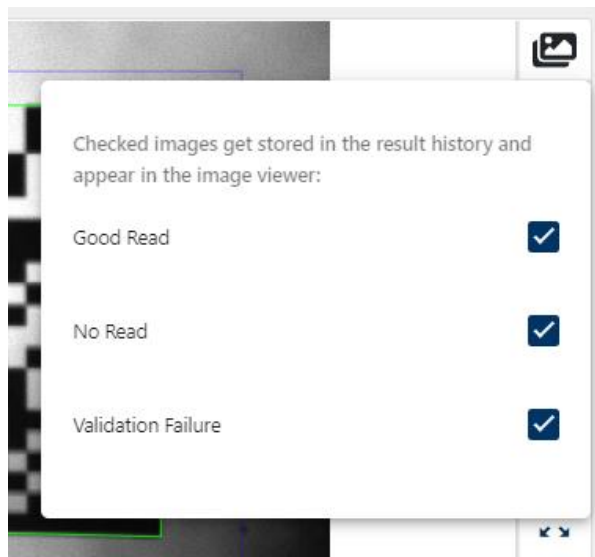
You can also filter the feed to display only **Good Read**, **No Read**, or **Validation Failure** results by clicking on the **Images** icon in the top right corner of the display.



The result logs of the last 50 captures are listed on the bottom of the page. You can browse the list using the navigation buttons in the bottom right corner of the pane.

Image	Result	Decode Time	Arrival Time	Read String
	✓	13ms	12:03:18.947 PM	12
	✓	12ms	12:03:17.783 PM	http://www.google.com
	✗	13ms	12:03:16.586 PM	

Items per page 3
 1 – 3 of 50

Click on the **Pause** button in the bottom left corner to pause the live feed. Pausing the feed allows you to select and download result images. Click on a log to put the result image on the display.

To download the image currently on the display, click on the **Download Result Image(s)** button without selecting any images from the result logs.

Check the checkboxes in the rightmost column of the result logs to select images for download, or check the checkbox in the table header to select all images. Click on **Download Result Image(s)** while multiple images are selected to download a ZIP file containing the selected result images.

Actions

The **Actions** page of the DataMan WebHMI allows you to manually trigger, start or stop, tune, or untrain the device.

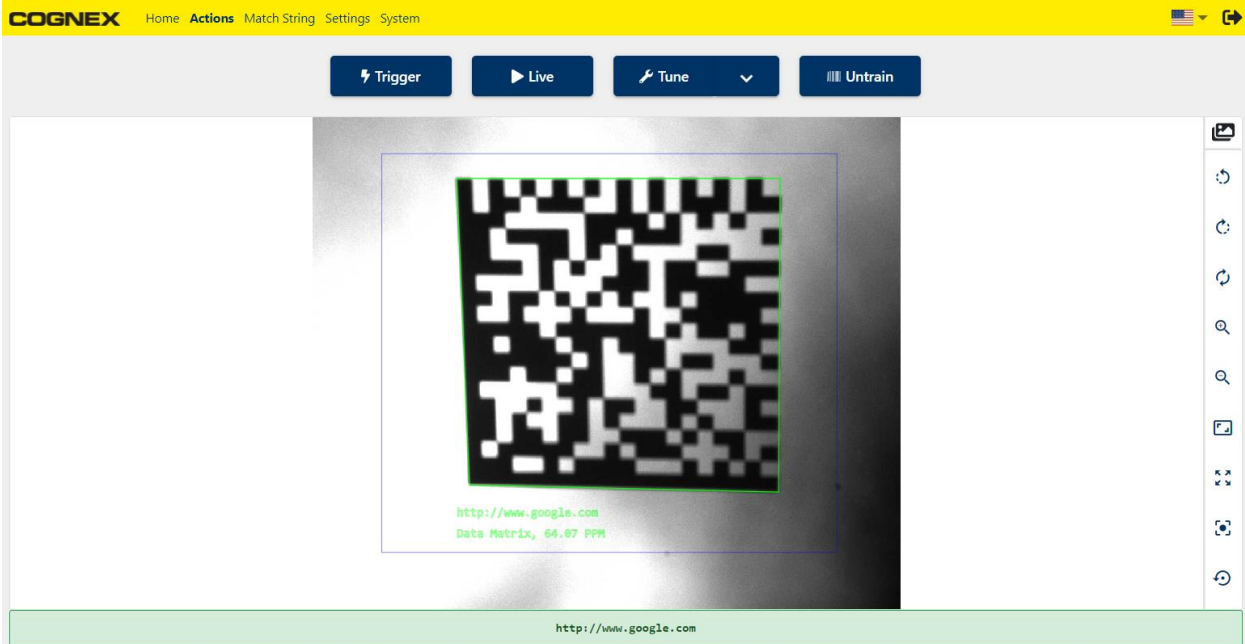

Click **Trigger** to trigger the device manually.

Click **Live** to show the live feed of the device camera.

Click **Tune** to initiate an automatic recalibration. Open the Tune dropdown to optimize brightness or focus individually.

Note: When you tune a device, the device stops triggering.

Click **Untrain** to untrain the device.

Settings

The **Settings** page of the DataMan WebHMI allows you to manually change the device configuration, upload, download, or save the current configuration, or reset the device to a previously saved configuration.

The screenshot shows the 'Settings' page in the COGNEX interface. At the top, there is a navigation bar with 'Home', 'Actions', 'Settings', and 'System'. Below this is a 'Table View' section with buttons for 'Expand All', 'Collapse All', 'Add New Read Setup', 'Upload', 'Download', 'Save', and 'Reset'. The main table has two columns: 'Variable Name' and 'Setup 0'. The table is divided into sections: 'Read Setup' and 'Tuning'. The 'Read Setup' section includes fields for Name (Setup 0), Enabled (checked), Enable Distance Check (unchecked), Min Distance (mm) (0), Max Distance (mm) (10000), Starting Setup (0), and Last Successful Decode (unchecked). The 'Tuning' section includes Train Code (checked).

Variable Name	Setup 0
Read Setup	
Name	Setup 0
Enabled	<input checked="" type="checkbox"/>
Enable Distance Check	<input type="checkbox"/>
Min Distance (mm)	0
Max Distance (mm)	10000
Starting Setup	0
Last Successful Decode	<input type="checkbox"/>
Tuning	
Train Code	<input checked="" type="checkbox"/>

- Click **Expand All** or **Collapse All** at the top of the page to expand or collapse the setting categories in the settings table.
- Click **Add New Read Setup** to create a new setup using default settings or an existing setup as a template.

The 'Add New Setup' dialog box contains a text input field for 'Setup name' with the value 'Setup 1'. Below it is a dropdown menu labeled 'Copy values from setup' with the selected option '--- use default settings ---'. At the bottom right, there are two buttons: 'ADD' (yellow) and 'CANCEL' (white).

- Click **Upload** to upload a local configuration file to the device.
- Click **Download** to save the device configuration locally.
- Click **Save** to save the configuration on the device flash memory.
- Click **Reset** to reset the device configuration to default or a saved configuration.

The settings table provides you with detailed and in-depth configuration options for all device functionality. Each setting corresponds to a control command for the reader. For a detailed description of the available settings for the reader you are configuring, see the corresponding control commands for the reader in the *DataMan Control Commands Documentation*.

System

The **System** page of the DataMan WebHMI displays detailed device information, reader statistics, feature keys, and device time.

COGNEX Home Actions Settings System

Device Information

Device Model:	Firmware Version:
Serial Number:	Installed Hardware: LiquidLens, Custom
Device Name:	Bootloader Version:
MAC Address:	OS Version:
IP Address:	

Feature Keys

1DCodeQuality, 1DDataStitching, 1DExtendedRes, 2DCode, 2DCodeQuality, BarCode, DotCode, IDMax, FullSpeed, IDQuick, ImageDownload, ImageFiltering, ImageFoV_Full, IntImageBuffer, LadderAndPicket, MST, Omnidirectional, PostalCode, PowerGrid, Scripting, SignopticSig, Validation

Device Time

Local Time:
Jan 26, 2019, 2:36:11 AM

Uptime:
601h 36m 13s

Reader Statistics

[Clear](#)

Total Triggers: 1,376,159	Missed Triggers: 0
Total Reads: 1,225,743	Passed Validations: 0
Read Rate: 89.07%	Failed Validations: 0
Total No-Reads: 150,416	Buffer Overflows: 0
No-Read Rate: 10.93%	Trigger Overruns: 0
	Item Count: 0

Feature Keys

The Feature Keys page shows the feature keys applied on each discovered reader.

Home > Device Management > Feature Keys

Upload feature keys | Download as CSV | Discover devices

Search

Standalone Devices

Unlocked

Actions	Name	Type	Firmware Version	Serial Number	Feature Keys	Task Status
					1DCodeQuality, 1DDataStitching, 1DExtendedRes, 2DCode, 2DCodeQuality, BarCode, DIM_IDMax, DotCode, FullSpeed, HDRIPlus, IDQuick, ImageDownload, ImageFiltering, IntImageBuffer, LadderAndPicket, Omnidirectional, PostalCode, PowerGrid, Scripting, Validation	
					1DCodeQuality, 1DDataStitching, 1DExtendedRes, 2DCode, 2DCodeQuality, BarCode, DIM_IDMax, DotCode, FullSpeed, HDRIPlus, IDQuick, ImageDownload, ImageFiltering, IntImageBuffer, LadderAndPicket, Omnidirectional, PostalCode, PowerGrid, Scripting, Validation, MST, PFP, SymbolDiagnosics	
					1DCodeQuality, 1DDataStitching, 1DExtendedRes, 2DCode, 2DCodeQuality, BarCode, DIM_IDMax, DotCode, FullSpeed, HDRIPlus, IDQuick, ImageDownload, ImageFiltering, IntImageBuffer, LadderAndPicket, Omnidirectional, PostalCode, PowerGrid, Scripting, Validation, MST, PFP, SymbolDiagnosics	
					1DCodeQuality, 1DDataStitching, 1DExtendedRes, 2DCode, 2DCodeQuality, BarCode, DIM_IDMax, DotCode, FullSpeed, HDRIPlus, IDQuick, ImageDownload, ImageFiltering, IntImageBuffer, LadderAndPicket, Omnidirectional, PostalCode, PowerGrid, Scripting, Validation, SymbolDiagnosics	
					1DCodeQuality, 1DDataStitching, 1DExtendedRes, 2DCode, 2DCodeQuality, BarCode, DIM_IDMax, DotCode, FullSpeed, HDRIPlus, IDQuick, ImageDownload, ImageFiltering, IntImageBuffer, LadderAndPicket, Omnidirectional, PostalCode, PowerGrid, Scripting, Validation	
					1DCodeQuality, 1DDataStitching, 1DExtendedRes, 2DCode, 2DCodeQuality, BarCode, DIM_IDMax, DotCode, FullSpeed, HDRIPlus, IDQuick, ImageDownload, ImageFiltering, IntImageBuffer, LadderAndPicket, Omnidirectional, PostalCode, PowerGrid, Scripting, Validation, SymbolDiagnosics	

Test

All

Actions	Name	Type	Firmware Version	Serial Number	Feature Keys	Task Status
					1DCodeQuality, 1DDataStitching, 1DExtendedRes, 2DCode, 2DCodeQuality, BarCode, DIM_IDMax, DotCode, FullSpeed, HDRIPlus, IDQuick, ImageDownload, ImageFiltering, IntImageBuffer, LadderAndPicket, MST, Omnidirectional, PostalCode, PowerGrid, Scripting, SymbolDiagnosics, Validation, PFP	
					1DCodeQuality, 1DDataStitching, 1DExtendedRes, 2DCode, 2DCodeQuality, BarCode, DIM_IDMax, DotCode, FullSpeed, HDRIPlus, IDQuick, ImageDownload, ImageFiltering, IntImageBuffer, LadderAndPicket, MST, Omnidirectional, PostalCode, PowerGrid, Scripting, SymbolDiagnosics, Validation, PFP	

The following actions are available:

- Uploading feature key files
- Downloading Feature Keys page information in CSV
- Discovering devices

Upload feature keys Download as CSV Discover devices	
Button	Description
Upload feature keys	Upload feature key files.
Download as CSV	Download device list with all data in CSV format.
Discover devices	Discover connected devices.

The Feature Keys page also allows comparing uploaded feature keys between readers in a group:

Feature Key Color	Description
BLUE	The feature is unlocked for the device.
RED	The feature is unlocked for some devices in the group, but not for the respective device.

Click the **Difference** dropdown menu to select the following menu items for comparison:

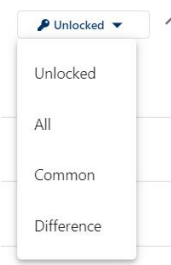

Item	Description
Unlocked	Show unlocked feature keys for all devices.
All	Show unlocked and locked feature keys for all devices.
Common	Show feature keys which are unlocked for all devices.
Difference	Show feature keys which have a different status among the devices.

Click the **Upload feature keys** button to upload a feature key file from your computer:

Upload feature key files

Only if device requires password for changes.

Browse Browse files with extension: .xml

Verification	File Name	Device Name	Serial Number	Feature Keys in File
✓				PTP MST

Cancel
Upload

Item	Description
Password	Password is only needed if the device requires a password.
Browse	Browse files with .xml extension on your computer.
Verification	Shows verified status.
File Name	Name of the feature key files.

Upload feature key files

Password

Only if device requires password for changes.

Browse Browse files with extension: .umf

Verification	File Name	Device Name	Serial Number	Feature Keys in File
✓				PTP MST

Cancel **Upload**

Item	Description
Device Name	Name of the device which gets the new feature key file.
Serial Number	Serial number of the device.
Feature Keys in File	Feature keys contained in the file.

Archiver

The **Archiver** application of EI Station Manager provides a method of storing and organizing data obtained from your readers, such as downloaded images and trigger sequences.

Download Center



The **Download Center** page of the Archiver application allows you to manage your current and historical archives.

When you download image or trigger data from the Results Explorer page of the Performance Analytics application, EI Station Manager stores it in an archive file. Downloaded archives reside on the hard drive of the EI Station Manager unit. The time it takes to create the archive depends on the size and the number of images that needs processing, and can take from around one minute to up to two hours. Depending on the amount of data, EI Station Manager generates one or more archives. The size limit for a single archive is 1 GB. When the remaining disk space approaches approximately 50 GB, EI Station Manager automatically starts to delete older images.



Note: Archives always have storage priority over the images stored in Results Explorer.

The Download Center page:

Home » Archiver » Download Center

Actions	Title	State	Queued At	Updated At	Files Count
	No Read Images 1:50PM-2:58PM	Completed	2/3/22, 8:57 PM	2/3/22, 8:57 PM	1
	Image + Trigger 1/20 10AM-1PM	Completed	1/20/22, 7:21 PM	1/20/22, 7:21 PM	1
	Image+trigger Jan4 1037-1237	Completed	1/5/22, 4:37 PM	1/5/22, 4:37 PM	1

Items per page: 10 11 - 13 of 13 |< < > >|

Column	Description
Actions	The possible actions for an archive. The following actions are available when clicking in the appropriate icon: <ul style="list-style-type: none">  deletes an archive  cancels the request to create the archive  resubmits the request to create the archive
Title	The user-specified name of the archive.
State	The status of the archive. Displays one of the following states: <ul style="list-style-type: none"> • Idle • Collecting Data • Running • Completed • Canceled
Queued At	The time when download starts.
Updated At	The time of the last status update or when the download finishes.
Files Count	The total number of ZIP files in the archive.

The archive file has the following contents:

- One or more folders that contain the images. EI Station Manager organizes the folders by date, and each folder name has the format of YYYYMMDD.



The images in each folder follow a naming convention based on whether they originate from a standalone reader or from an MRS group:

- For standalone readers, the image name contains the device name, the trigger index, the image index, and the time stamp, in this order and separated by underscores. For example, `ST_1_DM470_566898_0_20211221T190905.jpg`.
- For readers in an MRS group, the image name contains the group name, the device name, the trigger index, the image index, the time stamp, and four random characters to prevent name collision, in this order and separated by underscores. For example, `Tunnel1_ST_3_DM470_1126_0_20220204T141531_6802.jpg`.
- One CSV file that contains trigger data. The name of the file contains the MRS group name when applicable, and the name of the primary device, for example, `Tunnel_1_ST1_DM470.csv`. The file organizes data into the following columns:
 - time: The time stamp of the image.
 - deviceMacAddress: The MAC address of the device.
 - group: The MRS group name.
 - type: The trigger type
 - triggerIndex: The index of the trigger.
 - goodRead: TRUE indicates a Good-read, FALSE indicates a No-read.
 - readString: The read string. For an MRS group, this column contains the overall result string.



Note: For an MRS group, the image folder(s) contain images from all readers, and the CSV file contains trigger data from the primary reader.

Extract a Single Archive File

1. In the **Download Center**, click on the row of the archive you want to download to see its contents.

Actions	Title	State	Queued At	Updated At	Files Count
	4/8 10:47-10:50	Completed	4/8/22, 4:52 PM	4/8/22, 4:52 PM	1
<p><i>Download only one file at a time. Simultaneous downloads severely impact device performance. Download all partial zip archives (if created) before opening the '.zip' file. You may need a third-party utility to automatically combine partial archives.</i></p> <p> ei-data-export-20220408_1452-f61cd806-3697-4d56-a9c8-1686cc5feec2.zip</p>					

- Click on the download icon to download the ZIP file.

Actions	Title	State	Queued At	Updated At	Files Count
	4/8 10:47-10:50	Completed	4/8/22, 4:52 PM	4/8/22, 4:52 PM	1
<p><i>Download only one file at a time. Simultaneous downloads severely impact device performance. Download all partial zip archives (if created) before opening the '.zip' file. You may need a third-party utility to automatically combine partial archives.</i></p>					
<div style="border: 1px solid red; padding: 5px; display: inline-block;">  ei-data-export-20220408_1452-f61cd806-3697-4d56-a9c8-1686cc5feec2.zip </div>					

The default download location depends on the browser you are using.

- Navigate to the folder on your computer that contains your downloaded file, and extract the contents of the file.

Extract a Multi-Archive File

When the size of the archive exceeds 1 GB, EI Station Manager creates multiple partial ZIP files from that archive.

Note: As the built-in Windows file extractor cannot handle partial ZIP files, you need to install 7Zip or a similar program to manage them.

1. In the **Download Center**, click on the row of the archive that you want to download to see its contents.

Actions	Title	State	Queued At	Updated At	Files Count
	2/13-2/14 Images + Triggers	Completed	2/14/22, 6:16 PM	2/14/22, 6:21 PM	6
<p><i>Download only one file at a time. Simultaneous downloads severely impact device performance. Download all partial zip archives (if created) before opening the '.zip' file. You may need a third-party utility to automatically combine partial archives.</i></p> <p>↓ ei-data-export-20220214_1716-4e4d06cf-c77f-4054-baff-e2940a9c920f.z01</p> <p>↓ ei-data-export-20220214_1716-4e4d06cf-c77f-4054-baff-e2940a9c920f.z02</p> <p>↓ ei-data-export-20220214_1716-4e4d06cf-c77f-4054-baff-e2940a9c920f.z03</p> <p>↓ ei-data-export-20220214_1716-4e4d06cf-c77f-4054-baff-e2940a9c920f.z04</p> <p>↓ ei-data-export-20220214_1716-4e4d06cf-c77f-4054-baff-e2940a9c920f.z05</p> <p>↓ ei-data-export-20220214_1716-4e4d06cf-c77f-4054-baff-e2940a9c920f.zip</p>					

- Download each ZIP one at the time file by clicking on the download icon, and store them in the same location.

Actions	Title	State	Queued At	Updated At	Files Count
	2/13-2/14 Images + Triggers	Completed	2/14/22, 6:16 PM	2/14/22, 6:21 PM	6

Download only one file at a time. Simultaneous downloads severely impact device performance. Download all partial zip archives (if created) before opening the '.zip' file. You may need a third-party utility to automatically combine partial archives.

- [↓ ei-data-export-20220214_1716-4e4d06cf-c77f-4054-baff-e2940a9c920f.z01](#)
- [↓ ei-data-export-20220214_1716-4e4d06cf-c77f-4054-baff-e2940a9c920f.z02](#)
- [↓ ei-data-export-20220214_1716-4e4d06cf-c77f-4054-baff-e2940a9c920f.z03](#)
- [↓ ei-data-export-20220214_1716-4e4d06cf-c77f-4054-baff-e2940a9c920f.z04](#)
- [↓ ei-data-export-20220214_1716-4e4d06cf-c77f-4054-baff-e2940a9c920f.z05](#)
- [↓ ei-data-export-20220214_1716-4e4d06cf-c77f-4054-baff-e2940a9c920f.zip](#)

The default download location depends on the browser you are using.

- Navigate to the folder on your computer that contains all the downloaded partial ZIP files.
- Right-click on the file with ZIP extension.
- Click on the ZIP file extractor.
- Click on **Extract to** to merge all partial files.

Settings

The Settings application allows you to configure your Edge Device, set up MQTT and other IoT connections, enable or disable the DataMan WebHMI pages of your connected devices, and upgrade your device firmware.

Edge Device

The Edge Device page shows the network configuration and allows editing and saving the network settings of the EI Station Manager device.

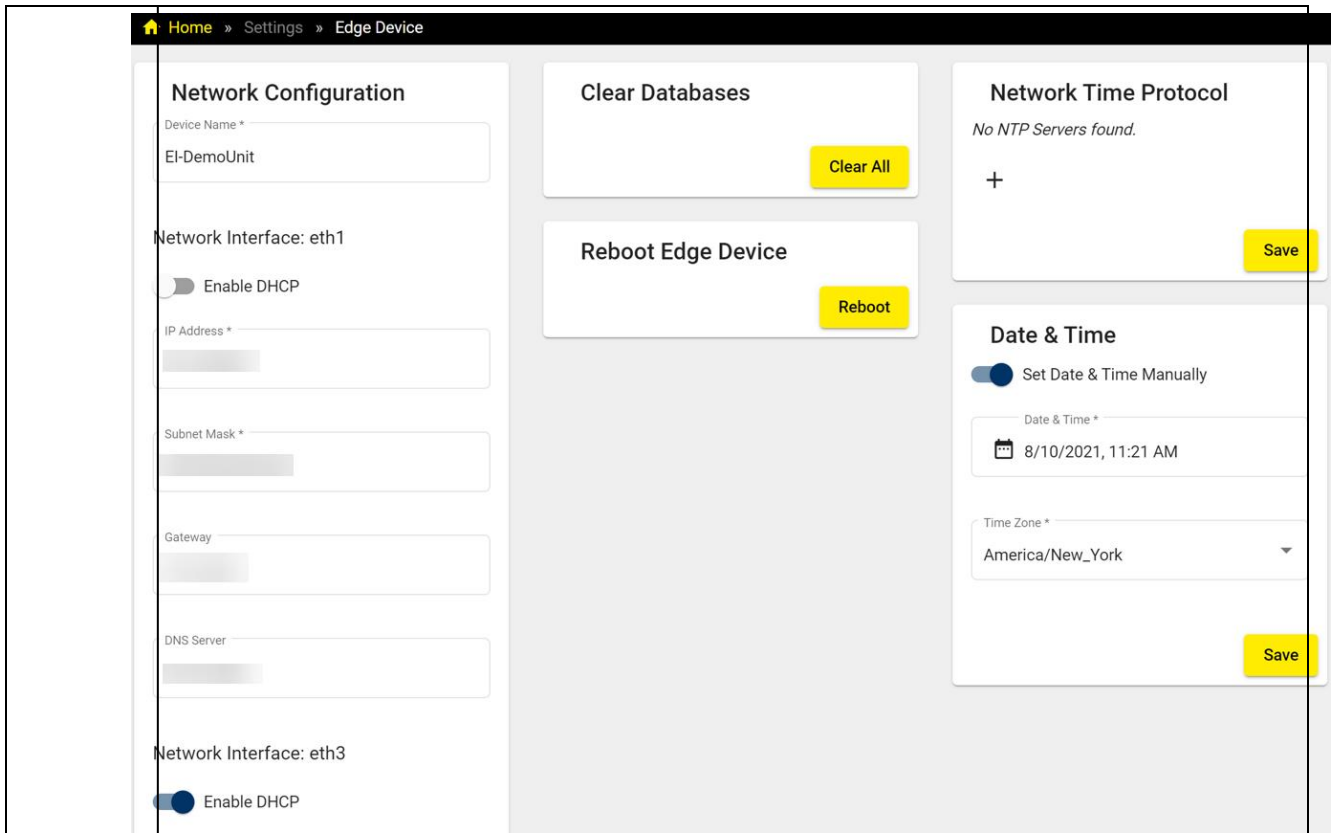

Section	Item	Description
Network configuration	Device Name	The name of the EI Station Manager device.
	Enable DHCP	To enable using DHCP protocols instead of static protocols toggle the switch.
	IP Address	The IP Address of the EI Station Manager device.
	Subnet Mask	The Subnet Mask of the EI Station Manager device. Note: Do not set more than one network port to the same subnet mask.
	Gateway	The Gateway of the EI Station Manager device.
Clear databases	You can clear the device lists, data, and images from the EI Station Manager device, and create a new state. Note: Clear database option is only available with Admin level clearance.	
Reboot Edge device	You can reboot the Edge device with the Reboot Edge device option.	

The screenshot displays the 'Edge Device' settings page. On the left, there are two network configuration sections: 'Network Interface: eth1' and 'Network Interface: eth3'. Each section includes a toggle for 'Enable DHCP', an 'IP Address *' field, a 'Subnet Mask *' field, a 'Gateway' field, and a 'DNS Server' field. In the center, there are two action buttons: 'Clear Databases' with a 'Clear All' button and 'Reboot Edge Device' with a 'Reboot' button. On the right, there are two more sections: 'Network Time Protocol' showing 'No NTP Servers found.' with a '+' button and a 'Save' button; and 'Date & Time' with a 'Set Date & Time Manually' toggle, a 'Date & Time *' field showing '8/10/2021, 11:21 AM', a 'Time Zone *' dropdown menu set to 'America/New_York', and a 'Save' button.

Section	Item	Description
Network time protocol		<p>You can sync the time between the EI Station Manager device and an NTP server. To Add New Address enter IP address of the NTP Server then click Save.</p>
Date and time		<p>Toggle Set Date and Time manually to specify the date, time and the time zone. For more information see Date & Time Range Filter on page 1.</p>

Setting up the NAT

Network address translation (NAT) remaps IP address spaces into other IP address spaces by modifying network address information in the IP header of information packets. Scroll down for the NAT option.

To set up the NAT:

1. Make sure that the Default Gateway of the DataMan readers is the IP address of the SM network port they are connected to.

- Set the switch to enable NAT Settings.

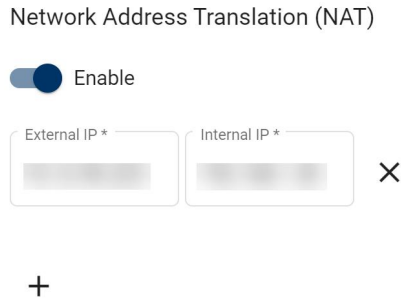

- Click the + symbol to Add New Mapping.
- Set the reader IP address as the Internal IP.
- For the External IP, enter an available IP address you want to map to the reader.
- Click Save.

NTP Server Function

The EI Station Manager device can act as a Network Time Protocol (NTP) server. NTP is an internet protocol for synchronizing clocks on a network to within a few milliseconds of universal coordinated time (UTC).

In the **Settings** menu, click on the **Edge Device** tab. Set the switch to **On** to enable NTP server and synchronize the date and time of your devices with the system time of EI Station Manager.

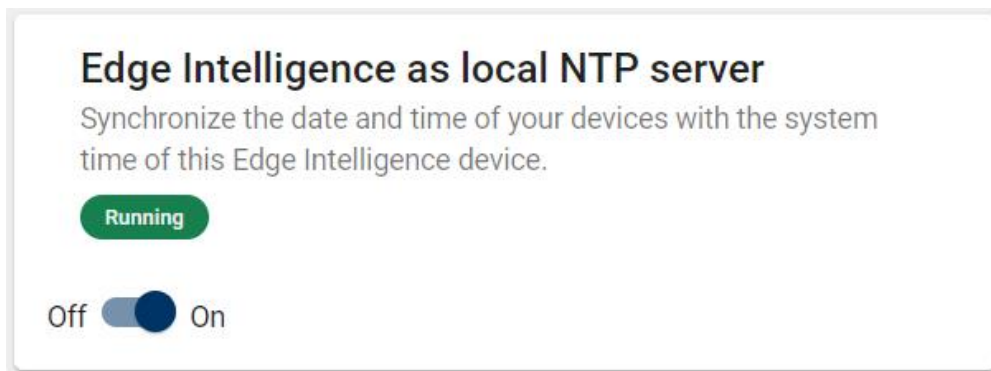

DataMan WebHMI

The **DataMan WebHMI** page of the **Settings** application allows you to enable or disable the pages displayed on the individual device DataMan WebHMI interfaces that are accessible through the **DataMan** page of the **Multi-Reader Configuration** application.

Select the device for which you want to change the displayed DataMan WebHMI pages from the device list on the left side of the page. The device information for the selected device appears under the list.

If the selected device is password protected, provide the password in the **Device Password** section of the page, otherwise you will not be able to save your changes.

You can enable or disable the following DataMan WebHMI pages for the selected device in the **Enabled Pages** section of the page:

- **Actions**
- **Match String**
- **Settings**

Click **Save** at the top of the page to apply your changes.

Firmware Upgrade

The **Firmware Upgrade** page of the **Settings** application step allows you to upload new firmware packages for upgrading device firmware.

If the EI Station Manager unit is on version 1.2.1 or later, you can upgrade the EI Station Manager firmware through the user interface by performing the following steps:

1. Make sure you are on the same network as EI Station Manager Internal Ethernet port. The IP address of the Internal Ethernet port is in the form of 192.168.1.X.
2. Connect to the EI Station Manager Internal Ethernet port. For more information, see [Connecting the EI Station Manager](#).
3. Open a web browser and type the IP address of the EI Station Manager unit into the address bar. The default static IP address is 191.168.1.100. The EI Station Manager user interface opens up.
4. Navigate to **Settings > Firmware Upgrade** in the EI Station Manager navigation pane.

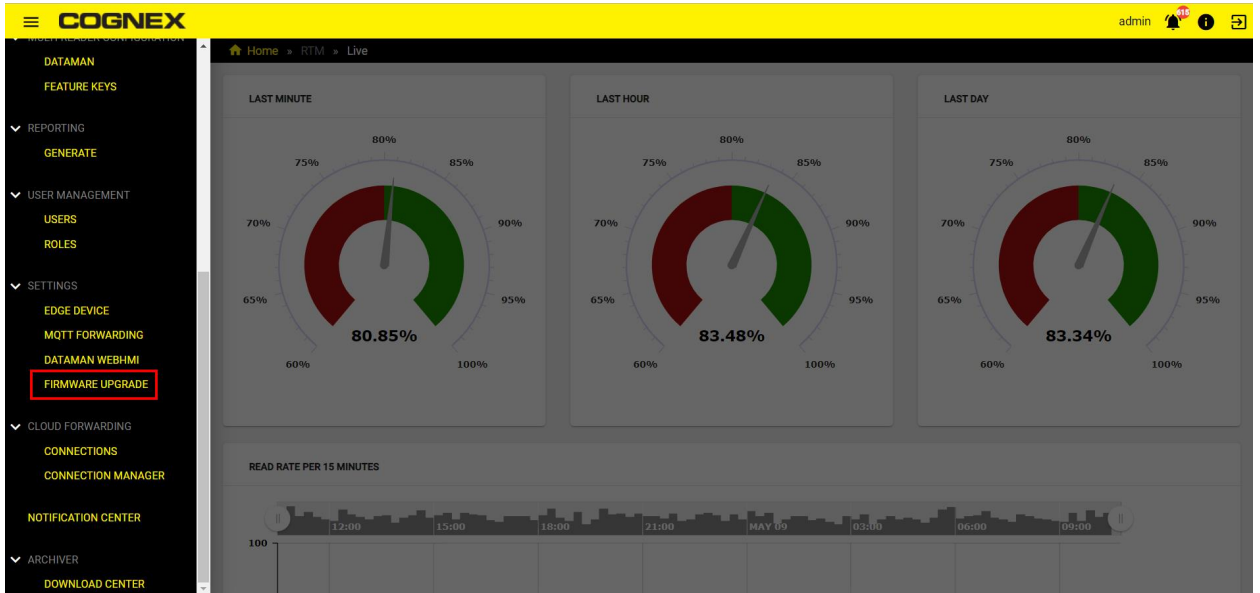

5. Click on the **Browse** button and select the latest firmware version available for download on the Cognex website. The firmware is a *.pkg* format file.

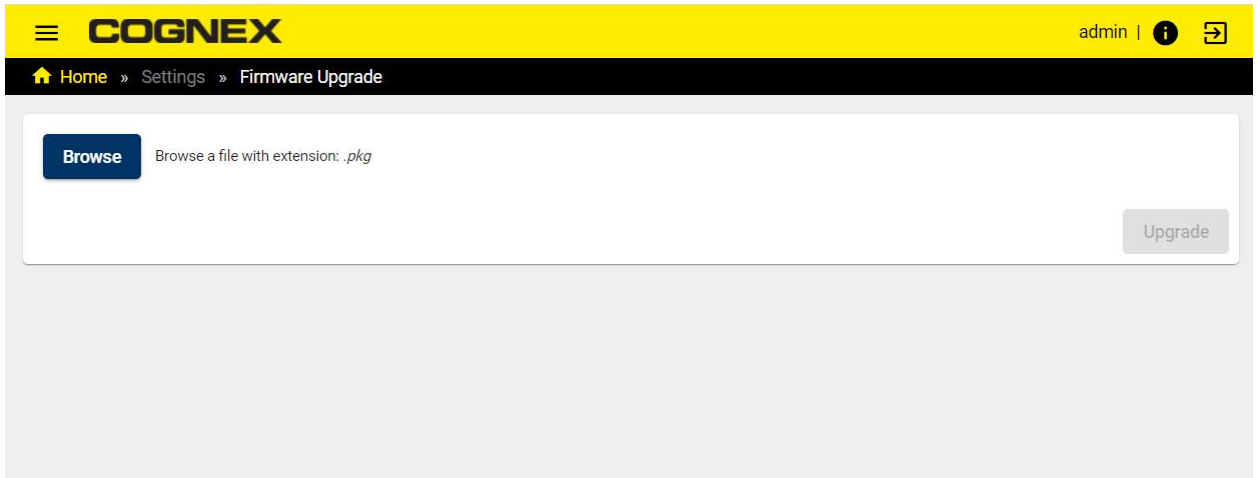

- Click on the **Upgrade** button and wait for upgrade to complete.

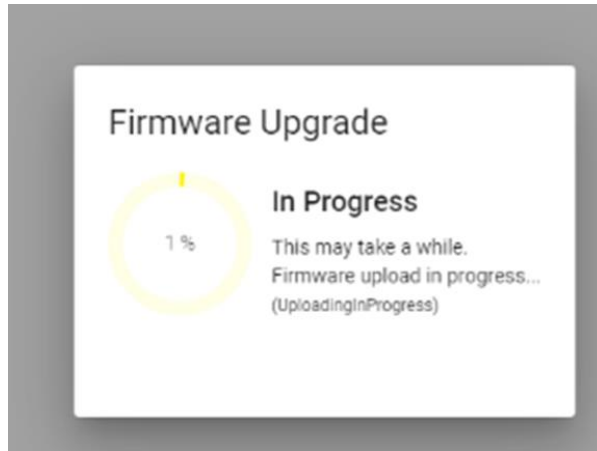

If the EI Station Manager unit is on version 1.1.1, you can upgrade EI Station Manager firmware through DataMan Setup Tool. For more information, see [Software Update](#).

HTTPS

HTTPS connection provides secure browser access to the EI Station Manager interface. HTTPS also enables the [Single Sign-On on page 64](#) feature.

HTTPS connection is enabled only if the Authority link in the [Identity Provider Configuration](#) uses the same HTTPS protocol. In this case, HTTP is disabled on the Identity Provider, and you are automatically redirected to HTTPS, which enforces a secure channel for authentication.

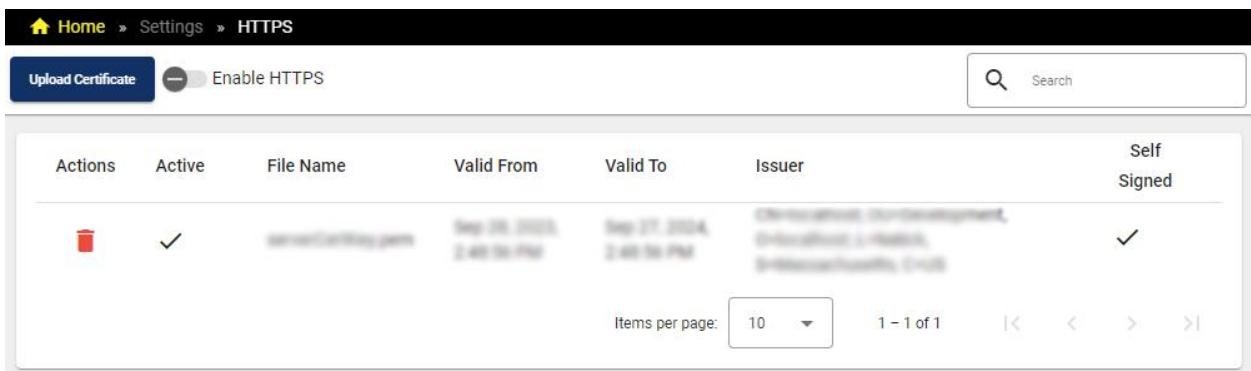

- Click **Upload Certificate** to add a .pem file.
- Click **Submit**.
- Turn on the **Enable HTTPS** toggle. You are automatically logged out.

4. Log in again to the EI Station Manager, either with the normal login or with Single Sign-On.

Username*

Password* 

Login

OR

Sign in with SSO

User Management

The **Roles** page allows an admin level user to create roles and define which EI features those roles have access to. The **User** page allows an admin level user to create users and assign them roles.

Users

The Users page allows creating new users and assigning Roles to them.

[Home](#) » [User Management](#) » [Users](#)

Create User 🔍 Search

Actions	Username ↑	Roles
✎ 🗑	admin	Admin

Items per page: 10 1 - 1 of 1 |< < > >|







Item	Description
Create User	Brings up the pop-up window to add a new user.
User management table	Table listing the existing users, the assigned Username and roles.

The **Create User** button is available on the top ribbon. Set the following options for each user:

Create User

Item	Description
Username	The username of the user for logging in.
Role	The role of the user: <ul style="list-style-type: none"> • Admin
Password	The password of the user for logging in.
Confirm Password	Reenter the password.

The Users page lists the existing users. Edit or delete an existing user by clicking the appropriate icon.

Icon	Description
<div style="border: 1px solid gray; padding: 10px; margin-bottom: 10px;"> <h3 style="text-align: center;">Actions</h3> <div style="display: flex; justify-content: space-around; margin-top: 10px;"> <div style="text-align: center;">  </div> <div style="text-align: center;">  </div> </div> <hr/> <div style="display: flex; justify-content: space-around; margin-top: 10px;"> <div style="text-align: center;">  </div> <div style="text-align: center;">  </div> </div> <hr/> <div style="display: flex; justify-content: space-around; margin-top: 10px;"> <div style="text-align: center;">  </div> <div style="text-align: center;">  </div> </div> </div>	Click Edit to edit the settings of a user.
	Click Delete to delete a user.

Roles

This page allows admin level users to create new roles and grant access to certain applications.

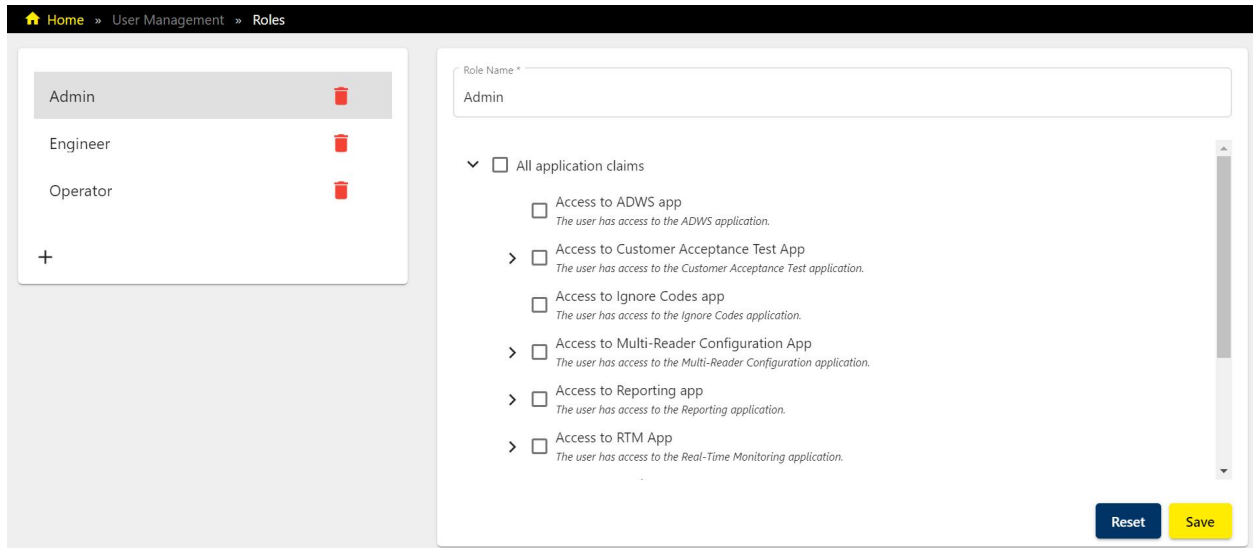

Item	Description
Roles	List of roles.
Accesses	List of accesses for the specified role.

The following predefined users are available by default:

Note: After creating the user profiles, always change the default password to avoid security risks.

User	Password	Permission
admin	BnthWWSD	Has access to all apps and features.
engineer	TaRDpKVx	Has access to all apps and features.
operator	SxtXGmxs	User with read-only rights. The operator does not have access to the Multi-Reader Configuration app and the Settings.

Single Sign-On

EI Station Manager supports Single Sign-On (SSO). Single Sign-On is a session and user authentication service that permits you to use a single set of login credentials. For example, you can set up a username and password that allows you to access multiple applications.

When choosing SSO on the EI Station Manager login page, you are directed to the authentication service login page where you provide your credentials. Once your credentials are validated, you are redirected back with the security token to EI Station Manager and logged in.

To configure this process on EI Station Manager, you have to configure roles and map these roles to an existing one in the customer identity provider. Then, you have to setup EI Station Manager as a client and configure return URLs. For more information, see [Role Mapping on page 65](#).

Identity Provider Configuration

To set up SSO in EI Station Manager, you log in to EI Station Manager using the admin credentials. The **Identity Provider Configuration** page of the **Single Sign-On** application allows you to enter the details of your configuration to setup the login with the existing environment.

After filling in the **Authority**, **Client ID**, **Client Secret**, **Role Claim Type**, and **User Name Claim Type** mandatory fields, click on **Save** to proceed.

Role Mapping

The **Role Mapping** page of the **Single Sign-On** application allows you to create external roles and map them to the internal roles that are system-provided default roles.

Click on **Create** on the top left corner of the **Role Mapping** page to create a role mapping.

The **Create Role Mapping** pop-up appears.

Create Role Mapping

External Role Name * Internal Role Name * 

+

Fill in any external role name in the **External Role Name** field and select an **Internal Role Name** from the default options.

Create Role Mapping

External Role Name * Internal Role Name * 

Admin

Engineer

Operator



Click on the **+** to add more role mappings.

Create Role Mapping

External Role Name * Internal Role Name * 

Admin Admin

External Role Name * Internal Role Name * 





Someone Engineer

+

After filling in the given fields you can click **Submit** to create the role mappings. The role mappings, now, appear.

Home > Single Sign-On > Role Mapping

[Create](#)

Actions	External Role Name	Internal Role Name
 	Admin	Admin
 	Someone	Engineer

Items per page: 10 1 - 2 of 2 |< < > >|

You can edit or delete any role mapping from the list by clicking on the corresponding button icons.

If you click on the **Pencil** icon, the **Edit Role Mapping** pop-up appears.

Edit Role Mapping

External Role Name * Internal Role Name *

To save your changes after editing, click on **Submit**.

Cloud Forwarding

The Cloud Forwarding application allows you to configure your cloud connections and manage the forwarded data. The Cloud Forwarding application contains two pages: Connections and Connection Manager.

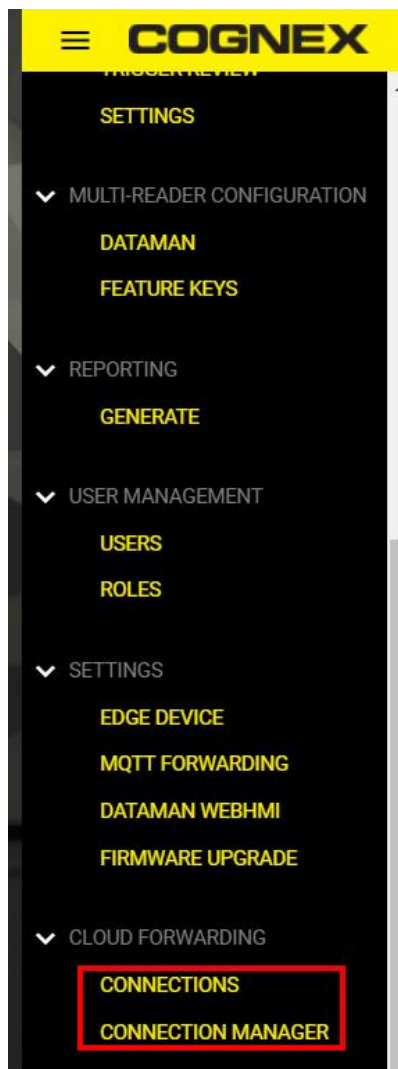

Connections

The **Connections** page of the **Cloud Forwarding** application displays the current status of the cloud connection and total number of images and messages uploaded or failed.

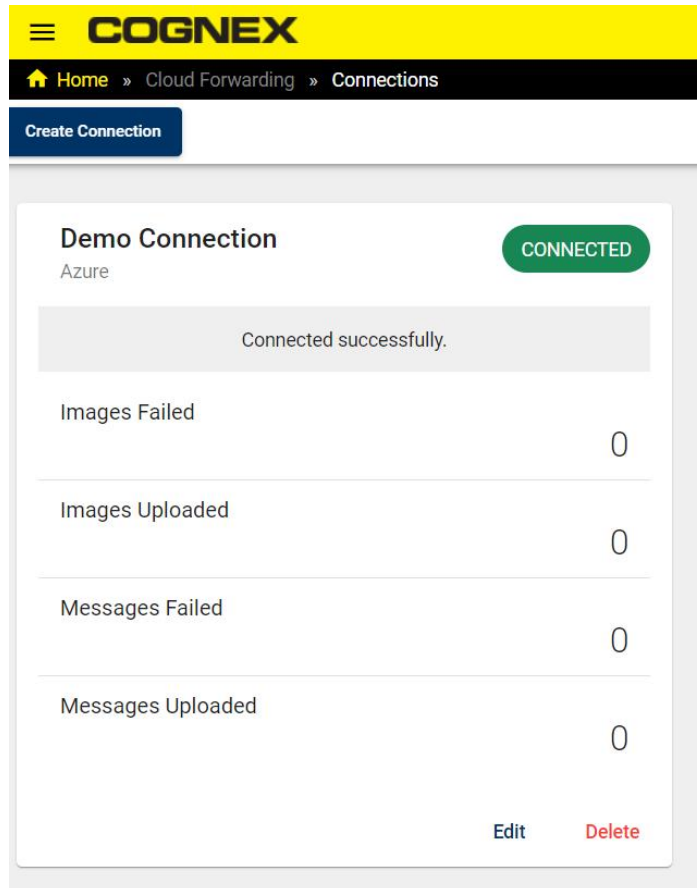

The screenshot shows the COGNEX user interface for the Connections page. At the top, there is a yellow header with the COGNEX logo and a navigation breadcrumb: Home » Cloud Forwarding » Connections. Below the breadcrumb is a blue button labeled "Create Connection". The main content area features a card for a "Demo Connection" to "Azure", which is currently "CONNECTED". A grey message box indicates "Connected successfully.". Below this, a table displays statistics for images and messages. At the bottom right of the card, there are "Edit" and "Delete" buttons.

Category	Count
Images Failed	0
Images Uploaded	0
Messages Failed	0
Messages Uploaded	0

To edit the connection, click on **Edit**. The **Edit Connection** pane opens up:

Edit Connection

Connection Name *
Demo Connection

Destination Type *
Azure

Connection Type *
Connection String

Connection Settings

Azure Connection String *
HostName=EI-Demo-IOTHub.azure-devices.net;DeviceId

Cancel Save

- The **Connection Name** field shows the name of the connection.
- The **Destination Type** dropdown shows where the data is forwarded to.
- The **Connection Type** dropdown shows the connection type, such as Connection String, SAS Token, x509 Certificate.
- In the **Azure Connection String** field you have to enter details for the specific connection type and destination.

Connection Manager

The **Connection Manager** page of the **Cloud Forwarding** application is for specifying the data to forward from each device.

The screenshot shows the 'Connection Manager' page with a table of 'Standalone Devices'. The table has columns for Primary, Name, IP Address, Model, Firmware Version, Password, and several forwarding options. The first row's forwarding options are highlighted with a red box.

Primary	Name	IP Address	Model	Firmware Version	Password	Forward Good Read Trigger	Forward Good Read Images	Forward No Read Triggers	Forward No Read Images	Forward Validation Failure Triggers	Forward Validation Failure Images	State
						<input checked="" type="checkbox"/>	<input checked="" type="checkbox"/>	<input checked="" type="checkbox"/>	<input checked="" type="checkbox"/>	<input checked="" type="checkbox"/>	<input checked="" type="checkbox"/>	In Local Subnet
						<input type="checkbox"/>	<input type="checkbox"/>	<input type="checkbox"/>	<input type="checkbox"/>	<input type="checkbox"/>	<input type="checkbox"/>	In Local Subnet
						<input type="checkbox"/>	<input type="checkbox"/>	<input type="checkbox"/>	<input type="checkbox"/>	<input type="checkbox"/>	<input type="checkbox"/>	In Local Subnet

To select the data to forward from each device, switch on the toggle. In this example, **Good Read Trigger, No Read Triggers, No Read Images, Validation Failure Triggers, Validation Failure Images** are chosen to forward for the first device in the list.

Data Transfer

EI Station Manager collects, parses, formats, and collates data from several readers.

Data Forwarding

You can forward device data to a different destination. EI Station Manager supports two connection types: MQTT and SFTP.

Note: To enable data forwarding, you need a license from Cognex.

Set Up MQTT Connection

1. Click **Create Connection**.
2. Choose MQTT.

Home » Data Transfer » Data Forwarding » Create Connection

Save Cancel

Select Your Connection Type

MQTT
Mqtt

SFTP
Sftp

Configure Your Connection

Choose application data to forward

3. Provide the **Connection Name**.

Configure Your Connection

Connection Name*

Authentication M...

4. Choose either Standard, TLS, or mTLS from the **Authentication Method** drop-down menu.

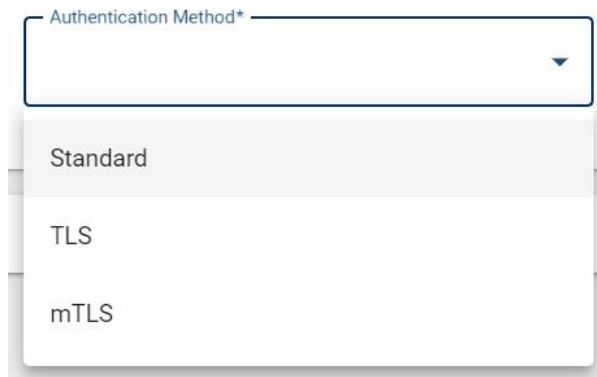

The image shows a dropdown menu for 'Authentication Method*'. The menu is open, displaying three options: 'Standard', 'TLS', and 'mTLS'. The 'Standard' option is highlighted with a grey background.

5. Enter the connection details, QoS, and Protocol Version for the MQTT broker.

Connection Settings

QoS Level

- 0 - at most once 1 - at least once 2 - exactly once

Protocol Version

- 3.1.1 5

- Choose the application data you want to forward and from which device. Under **Device Data** and **Tunnel Data**, you can choose specific data from each device by checking the corresponding box.

Device Data

Image Results Results Statistics

Device	Good Read Image	No Read Image	Validation Failure Image	Image SVGs
EI-test-group	<input type="checkbox"/>	<input checked="" type="checkbox"/>	<input type="checkbox"/>	<input type="checkbox"/>
...	<input type="checkbox"/>	<input checked="" type="checkbox"/>	<input type="checkbox"/>	<input type="checkbox"/>

Tunnel Data

Results

Device	Tunnel Trigger Result
EI-test-group	<input checked="" type="checkbox"/>
...	<input checked="" type="checkbox"/>

- Click **Save**.
- Your connection is now listed on the **Data Forwarding** page. You can edit, pause, and delete connections here.

Home » Data Transfer » Data Forwarding

Create Connection

Actions	Name	Type	Status	Last Message Sent
	...	Mqtt	Disconnected	13h, 21m

Set Up SFTP Connection

1. Click **Create Connection**.
2. Choose SFTP.

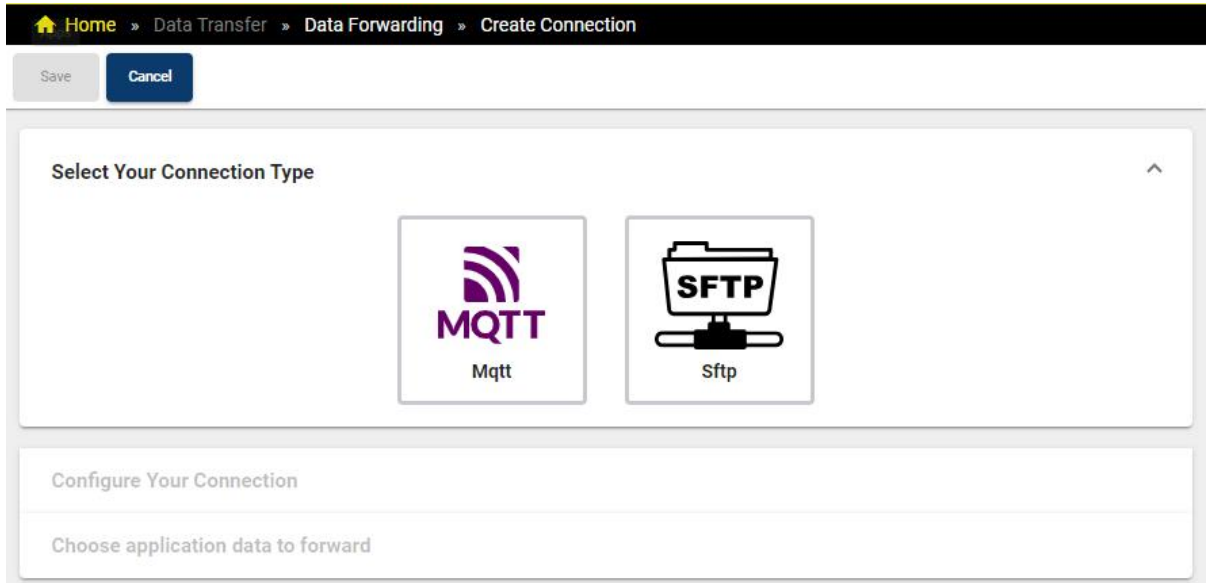

3. Provide the **Connection Name**.

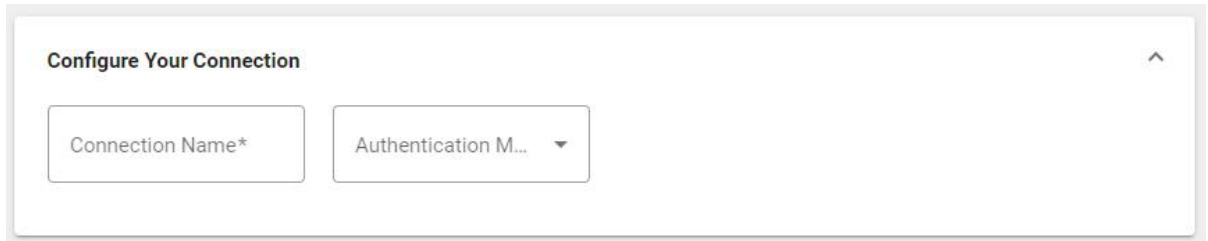

4. Choose Standard or Private Key from the **Authentication Method** drop-down menu.



5. Define a custom file path.

Define Your Custom File Path

File Path*

Click a token below to add it to the file path.

<p>Event Information</p> <ul style="list-style-type: none"> + <EventType> Notifies if the result is an image event or data event. + <CorrelationId> Unique ID for each trigger event. + <FileExtension> File extension of the incoming message. 	<p>Time Information</p> <ul style="list-style-type: none"> + <Timestamp> The timestamp recorded for the trigger result <Date> + Date in format YYYYMMDD (e.g: 2020-12-31T01:02:03Z -> 20201231) <Time> + Time in format hhmmss (e.g: 2020-12-31T01:02:03Z -> 010203) <Day> + Day from timestamp (e.g: 2020-12-31T01:02:03Z -> 31) <Month> 	<p>Image Information</p> <ul style="list-style-type: none"> + <ImageIndex> Image number for a trigger. + <Group> MRS group name the image is originating from. + <TriggerIndex> Trigger index for which is image is for. <DeviceMacAddress> + MacAddress of the device which generated this image. + <SourceDeviceName> Name of the device which generated this image.
---	--	--

6. Choose the application data you want to forward and from which device. Under **Device Data** and **Tunnel Data**, you can choose specific data from each device by checking the corresponding box.

Device Data ✓

	Image Results ✓	Results	Statistics						
El-test-group	Device	<input type="checkbox"/>	Good Read Image	<input checked="" type="checkbox"/>	No Read Image	<input type="checkbox"/>	Validation Failure Image	<input type="checkbox"/>	Image SVGs
...	...	<input type="checkbox"/>		<input checked="" type="checkbox"/>		<input type="checkbox"/>		<input type="checkbox"/>	

Tunnel Data ✓

	Results ✓	
El-test-group	Device	<input checked="" type="checkbox"/> Tunnel Trigger Result
...	...	<input checked="" type="checkbox"/>

7. Click **Save**.

8. Your connection is now listed on the **Data Forwarding** page. You can edit, pause, and delete connections here.

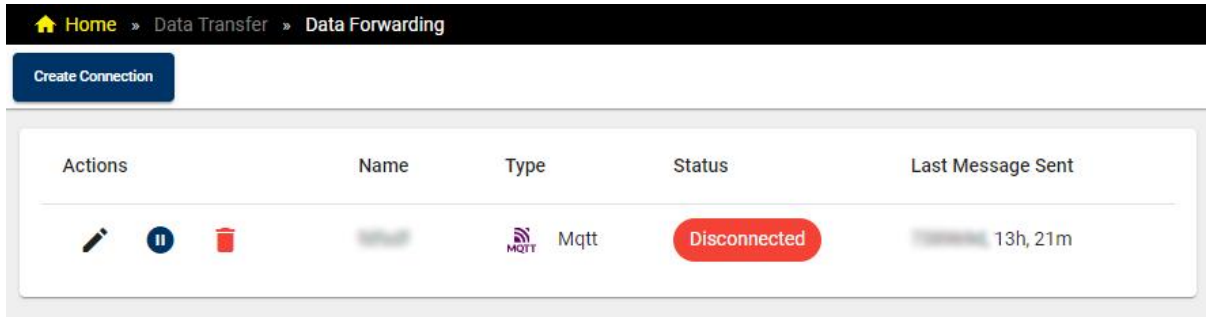

Notification Center

The Notification Center allows you to filter and sort the notifications that El Station Manager sends you. You can access the Notification Center from the main menu or from the notification bell icon.

For access from the main menu, click on the **Menu** icon and select **Notification Center**.

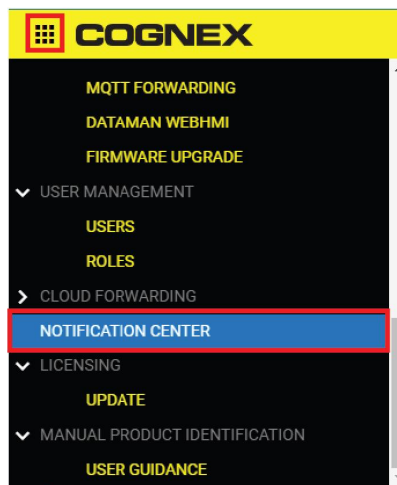

For access from the notification bell, click on the bell icon in the upper right corner of the home page to see the latest notifications.

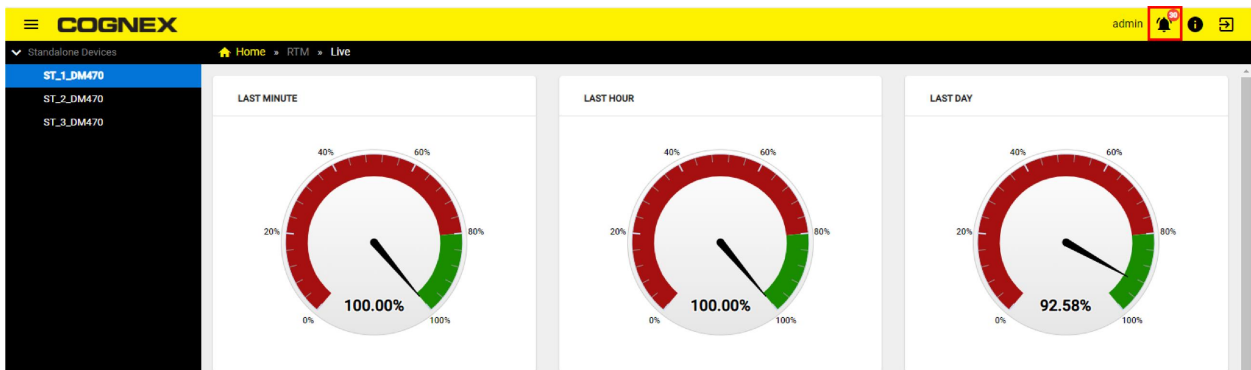

Click on the **See All** button to open the Notification Center.

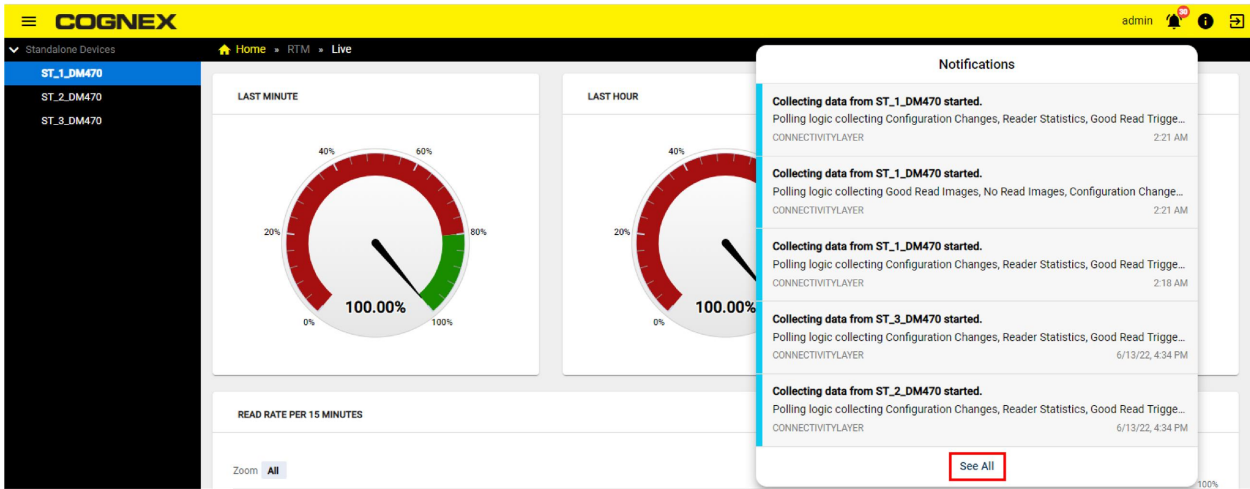

Notification Center Features

The screenshot shows the COGNEX Notification Center interface. The header includes the COGNEX logo and user information (admin). The main content area is divided into several sections. On the left, there is a sidebar with 'Sort Options' and 'Filter Options'. The 'Sort Options' section includes a 'Sort By' dropdown menu set to 'Arrived At' and a 'Sort Direction' dropdown menu set to 'Descending'. The 'Filter Options' section includes a 'Filter' dropdown menu set to 'Arrived At', a 'Created At' dropdown menu, and a 'Service Name' input field. Below the filter options, there are two buttons: 'Mark Filtered As Read' and 'Reset All Options'. The main content area displays a list of notifications. The first notification is titled 'Network availability changed' and states 'Network 'eth2' is available.' It includes details such as 'Service Name: NetworkManager', 'Title: Network availability changed', 'Details: Network 'eth2' is available.', 'Level: Info', 'Creation Time: x/x/xx, 11:49:55.804 PM', and 'Arrival Time: x/x/xx, 11:49:55.805 PM'. A 'Mark As Read' button is located at the bottom right of the notification card. The second notification is titled 'Network availability changed' and states 'Network 'eth2' is not available anymore.' At the bottom of the notification list, there is a pagination control showing 'Items per page: 5' and '1 - 5 of 17461'. The interface is annotated with numbered callouts: 1 points to the 'Sort By' dropdown, 2 points to the 'Filter' dropdown, 3 points to the 'Mark Filtered As Read' button, 4 points to the 'Reset All Options' button, 5 points to the 'Mark As Read' button, and 6 points to the pagination control.

Number	Element	Description
1	Sort By	Sort By
2	Filter	Filter
3	Mark Filtered As Read	Mark Filtered As Read
4	Reset All Options	Reset All Options
5	Mark As Read	Mark As Read
6	Items per page	Items per page: 5

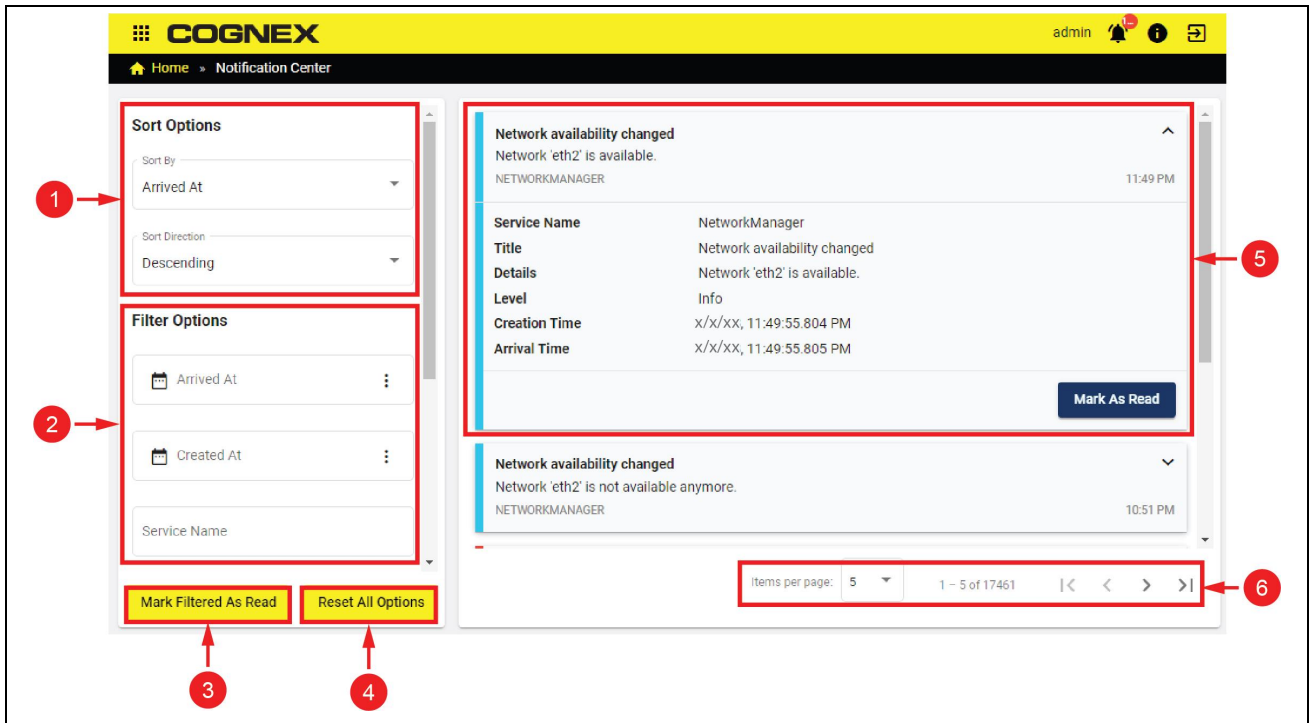

<p>1</p>	<p>Sort Options</p>	<p>Click on the Sort By dropdown to sort your notifications according to the following options:</p> <ul style="list-style-type: none"> • Service Name: Sorts the notifications according to service name of the notifications. • Created At: Sorts the notifications according to the date of creation. • Level: Sorts the notifications according to the level of the notification (Info, Warning, Error, or Critical). • Is Read: Sorts the notifications according to whether the notification is read. • Arrived At: Sorts the notifications according to the date of arrival. <p>Click on Sort Direction dropdown to determine the order of the notifications:</p> <ul style="list-style-type: none"> • Ascending • Descending
----------	---------------------	---

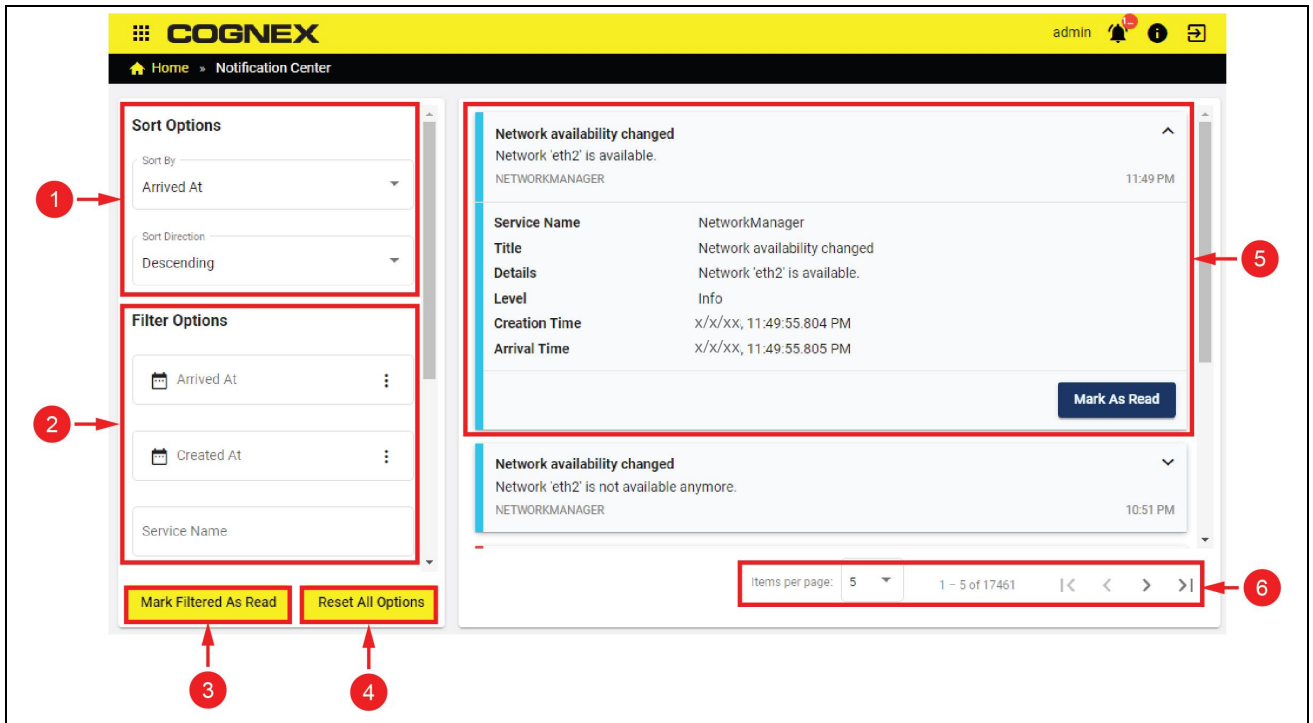

2	Filter Options	<p>You can filter the notifications by using the following filter options:</p> <ul style="list-style-type: none"> • Arrived At: When the notification arrived in the Notification Center. • Created At: When the notification is created. • Service Name: Type in the Service Name of the notification. • Title: Type in the title of the notification. • Details: Type in the details of the notification. • Is Read: Filters your notifications according to the status of the notification (Read/Unread). • Notification Level: Filters according to level (Info, Warning, Error, or Critical).
3	Mark Filtered as Read	Mark the filtered notifications as read.
4	Reset All Options	Clears the selected Sort and Filter options.

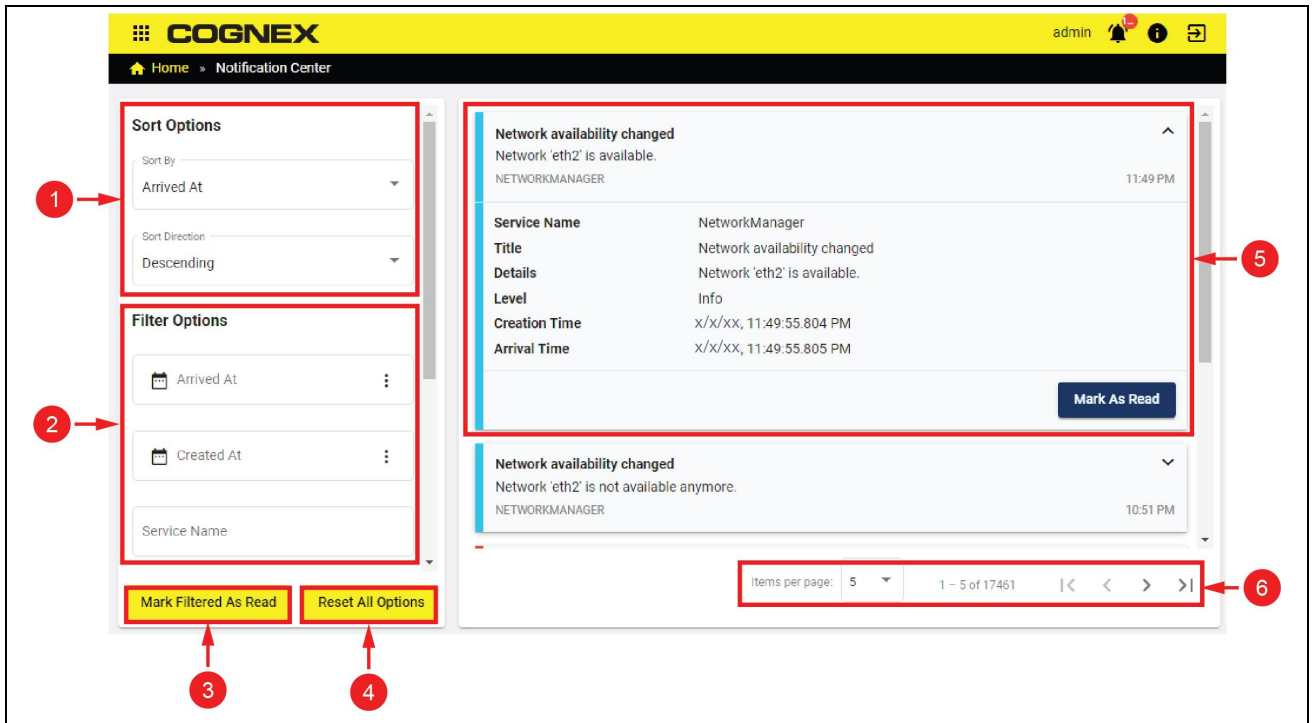

5	Notification	Click on the notification to see the details. Click on the Mark as read button to mark the notification as read.
6	Paging buttons	Click on the Items per page dropdown to choose the number of notifications showed on the screen. Click on the arrows to turn pages between the notifications.

Notification Levels

The Notification Center displays four levels of notifications:

- **Info:** Updates about general processes. No action is required.
- **Warning:** Caution, your process can be halted. You have to resolve the issues in the notifications before continuing.
- **Error:** Blocks your process. You have to resolve the issues in the notifications before continuing.
- **Critical:** Your process is no longer working. You have to resolve the issues in the notifications before continuing.

Notification List

Service Name	Event	Notification Level	Title	Message
ALERT	When an alert gets triggered.	Info, Warning, Error	<Alert Name>	<Alert Description>

Service Name	Event	Notification Level	Title	Message
ARCHIVER	Archiving process started, collecting data.	Info	Collecting data for <existingProcess.Title>	Archiving process <existingProcess.Title> (ID: <processId>) has started collecting data.
	The zipping process started.	Info	Started <existingProcess.Title>	Archiving process <existingProcess.Title> (ID: <processId>) has been started.
	The zipping process finished.	Info	Finished <existingProcess.Title>	Archiving process <existingProcess.Title> (ID: <processId>) has been finished successfully.
	Archiving process cancelled.	Info	Cancelled <existingProcess.Title>	Archiving process <existingProcess.Title> (ID: <processId>) has been cancelled.
	Failed running the archiving process.	Error	Failed <existingProcess.Title>	Archiving process <existingProcess.Title> (ID: <processId>) has failed.
	Failed cancelling the archiving process.	Error	Failed to cancel <existingProcess.Title>	Archiving process <existingProcess.Title> (ID: <processId>) has been failed to cancel.
COGNAMER	CogNamer packet initiated reboot.	Warning	Packet initiated reboot	Reboot has been initiated on the EI Station Manager box remotely via CogNamer. Wait until it boots up before applying any new modifications.
CONNECTIVITYLAYER	ConnectivityLayer started polling data from device.	Info	Collecting data from <_device.Name> started.	Polling logic collecting <requestedEvents> from the device.
	Could not log in to device to collect data.	Error	Could not login to device <_device.Name>	Polling logic failed to login to device.
	Could not connect to device to collect data.	Error	Collection stops for device <_device.Name>	Polling logic failed to connect to or get data from the device.

Service Name	Event	Notification Level	Title	Message
FILESTORAGE	FileStorage recovered from database errors.	Info	File save restored	Saving to the database has been recovered.
	Low free space is detected.	Error	Storage manager failure	Your SSD has reached critical storage limit. Please reboot the system to try and restore storage management. Call Cognex tech support if you see this error again.
FIRMWAREUPGRADE	Firmware upgrade started.	Info	Firmware upgrade	Firmware upgrade process has been started on the EI Station Manager box.
	Firmware upgrade finished.	Info	Firmware upgrade	Firmware upgrade process has been finished. The EI Station Manager box is going to be restarted soon. Wait until it boots up before applying any new modifications.
NETWORKMANAGER	The availability of one of network interfaces of the box changed.	Info	Network availability changed	Network <Network Name> is available.
	After network settings have been saved.	Warning	Reboot is initiated	Network setting changes were successfully saved. The system is going to be rebooted shortly.
	When someone reboots the box from the UI.	Warning	Manually initiated reboot	A reboot has been initiated on the EI Station Manager box. Wait until it boots up before applying any new modifications.

Service Name	Event	Notification Level	Title	Message
MQTTFORWARDING	On updating MQTT settings.	Info	MQTT settings updated	Applying new MQTT connection settings. Failed connections will result in an error notification.
	On successful connection to MQTT server.	Info	Connection successful	Successfully connected to MQTT server.
	On unsuccessful connection to MQTT server.	Error	Failed to connect	<ul style="list-style-type: none"> • Connection accepted. • Attempted to connect with MQTT v3.1.1 but server rejected that protocol version. • Attempted to connect with Client ID 'EI00D0COGNEX' but server rejected that ID. • Network Connection made but the MQTT server is unavailable at <IP address>:<port>. • Server rejected username and password. Check user credentials on the MQTT Forwarding page. • Client is not authorized to connect to the MQTT server at <IP address>:<port>. • Failed to connect with MQTT Return Code 6.
	On disconnection with MQTT server.	Error	Unexpected MQTT disconnection	Unexpected disconnection from MQTT server. Attempting to reconnect.
	On failure to reconnect with MQTT server.	Error	Failed to connect	The connection attempt to the MQTT server at <IP address>:<port> failed due to a connection timeout. Automatically retrying.
TUNNELMANAGER	On license activation.	Info	License activated	The EI Station Manager license has been activated.
	On license expiry.	Warning	License expired	The EI Station Manager license has expired. Limited capabilities are available.

Licensing

The **Licensing** application of the EI Station Manager user interface allows you to update your licenses using the **Update** page.

Update

The **Update** page of the **Licensing** application allows you to update your licenses.

To update your EI Station Manager software license, perform the following steps:

1. From the license table, click the **Download** button next to the license you want to update. This downloads a *.WibuCmRaC* file.

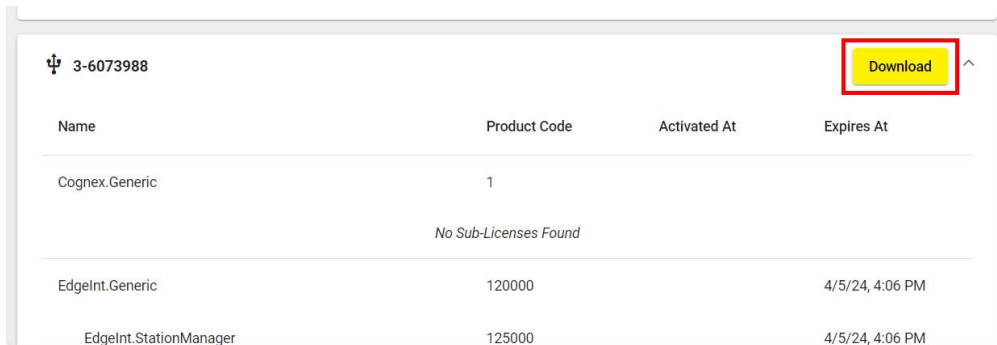

2. Log into MyCognex on the [Cognex support site](#), and click **Create New Support Request** on the home page to create a request for your field software upgrade. After filling in the title and description, submit the request.

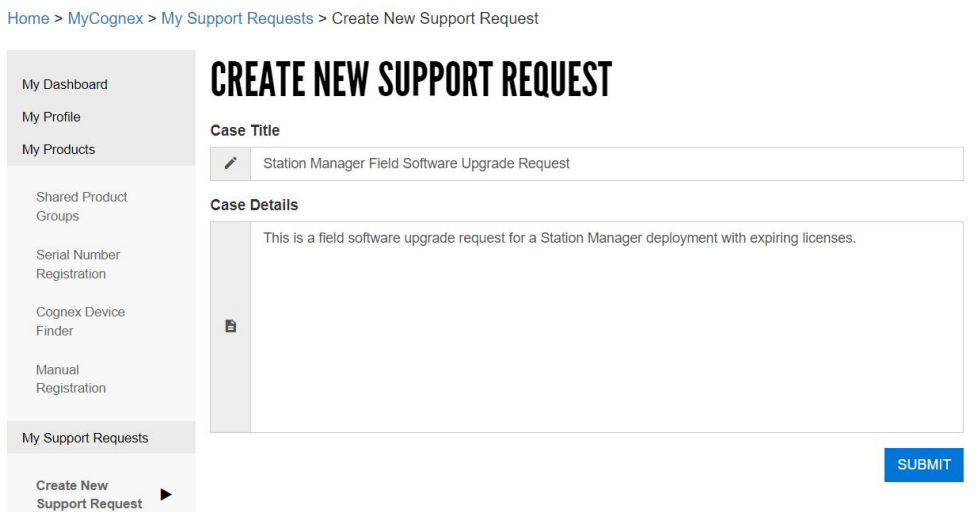

3. After you have submitted your request, attach the *.WibuCmRaC* file you downloaded in the first step to the request.
4. Once Cognex Technical Support has processed your request, you will receive an updated *.WibuCmRaU* license file.

- Return to the **Update** page of the **Licensing** application in the EI Station Manager UI, and click **Update License** in the top left corner of the page.

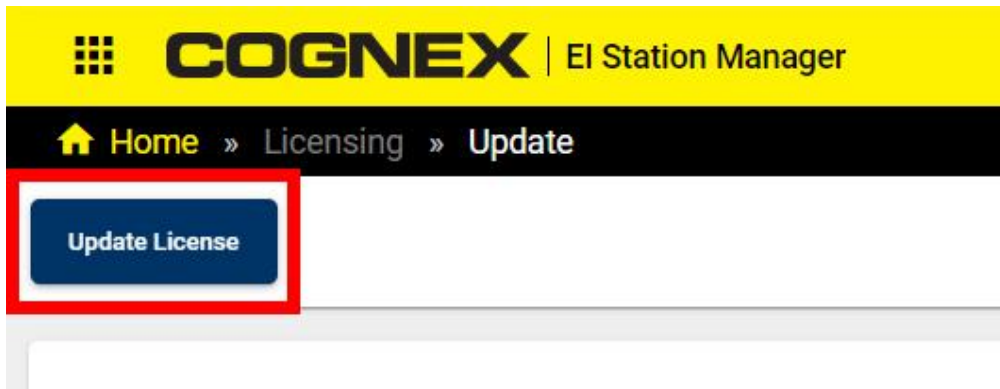

- In the **Update License** dialog, click **Choose a .WibuCmRaU file** to open the file browser, and select the file provided by Cognex Technical Support.

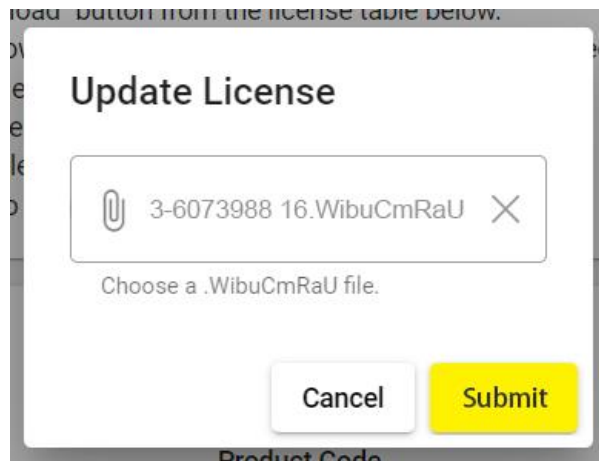

- Click **Submit** to complete the license update process.
- Verify that the license expiration date has been updated in the license table.

Software Upgrade

You can upgrade your EI Station Manager unit to the latest firmware version using one of the following methods:

- Using the Firmware Upgrade app on the EI Station Manager UI
- Using the DataMan Setup Tool

Using the Firmware Upgrade App

Applicable versions:

- Edge Intelligence 1.4.6
- Edge Intelligence 1.4.6-hotfix.1
- Station Manager 1.0

To upgrade the firmware on your EI Station Manager unit using the Firmware Upgrade app:

1. Open the UI and log in with your credentials.
2. Open the app list using the app icon in the top left, and select **Firmware Upgrade** under the **Settings** section.
3. In the **Firmware** dropdown, select the .pkg file for the latest firmware version.
4. Click **Upgrade** and wait for the UI to return that the process is complete.

Note: If a timeout error occurs during the upgrade, allow 10-15 minutes for the new system to fully boot up before refreshing your browser and logging in again. If you experience any login issues, clear the cookies in your browser.

Using the DataMan Setup Tool

Applicable versions:

- Edge Intelligence 1.3.1
 - Edge Intelligence 1.4.0
 - Edge Intelligence 1.4.1
1. Make sure that the DataMan Setup Tool identifies the EI Station Manager system as an accessible network device. If the DataMan Setup Tool has not yet identified the EI Station Manager system, navigate to the **Maintenance: Repair and Support** menu and click **Add Network Device**.

Note: If the DataMan Setup Tool already recognizes and lists the EI Station Manager system as an accessible device, skip **Step 1** and **Step 2**.

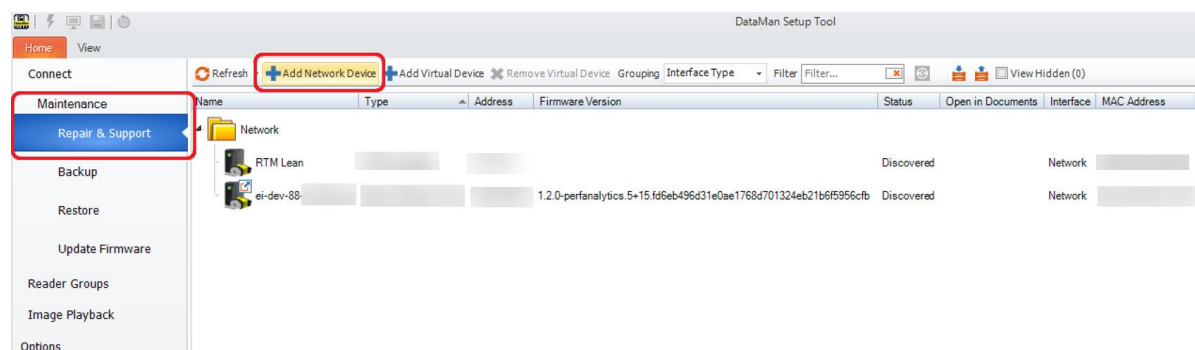

- Specify the EI Station Manager system by entering the IP address then click **OK**.

Add Network Device

IP Address:

OK Cancel

Note: Click the **Pen Symbol** to enable pasting a copied address. Clicking the **Pen Symbol** alternates between an automatically segmented and a manually segmented address format.

- Navigate to the **Maintenance: Update Firmware** menu.

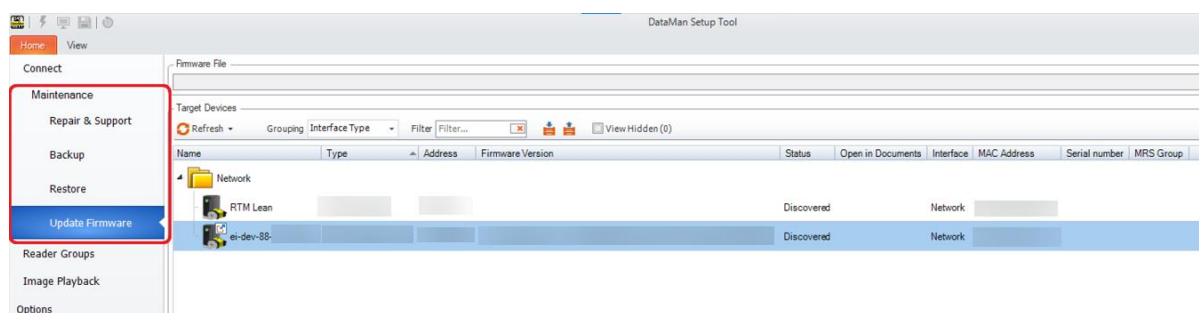

- Select your EI Station Manager device and browse the appropriate **.pkg** file from the Cognex network or local directories by clicking the ellipsis icon.

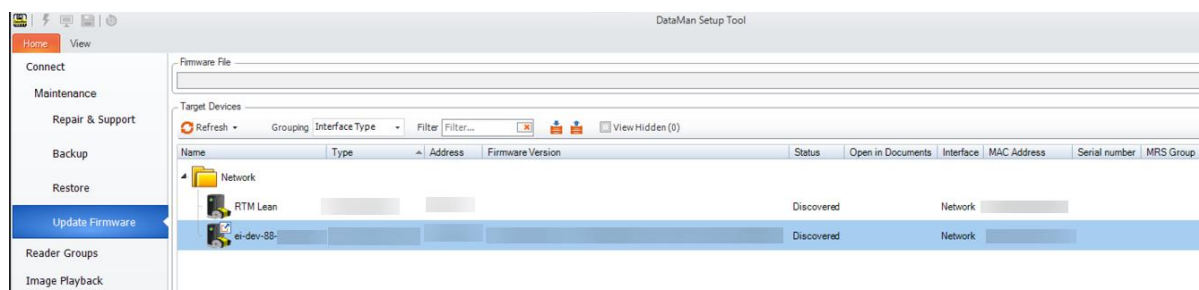

5. Select the .pkg file and click **Open**.

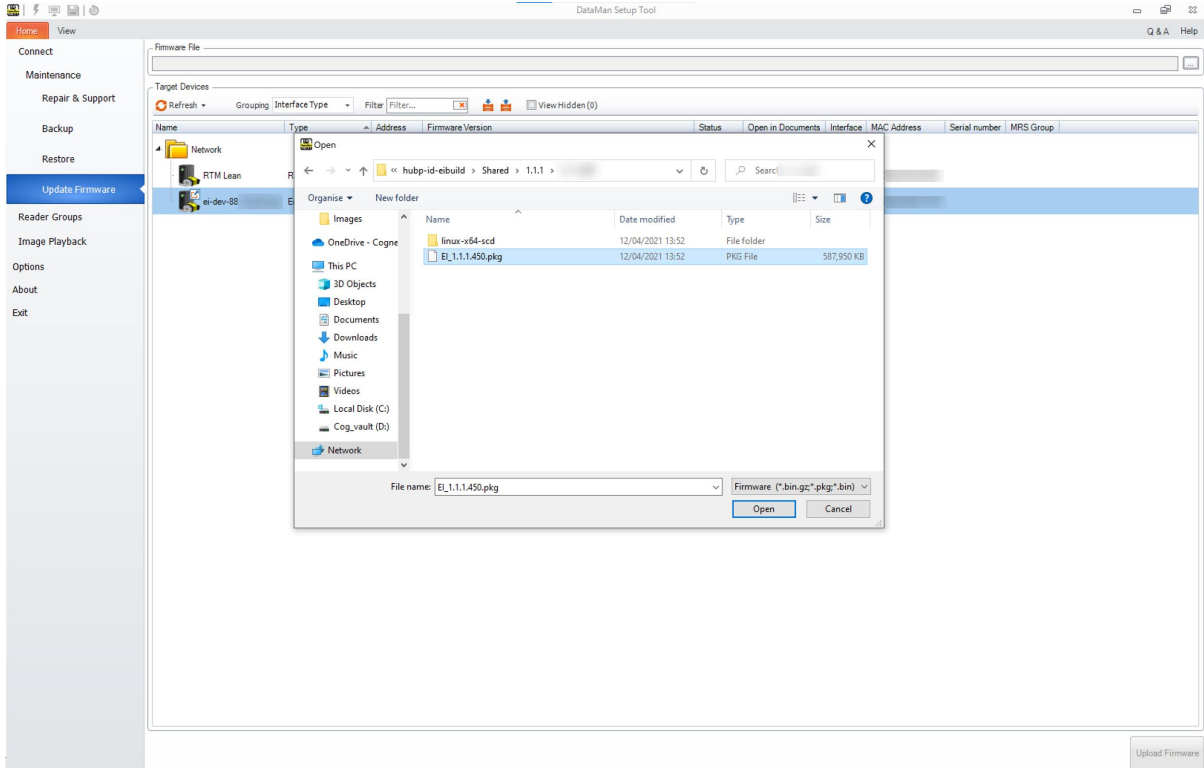

6. Click the **Upload Firmware** button.

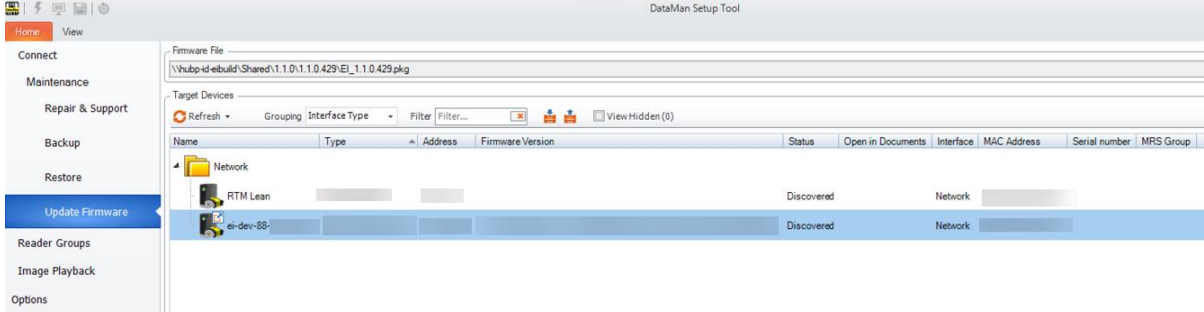

7. Confirm the firmware update by clicking **Yes**.

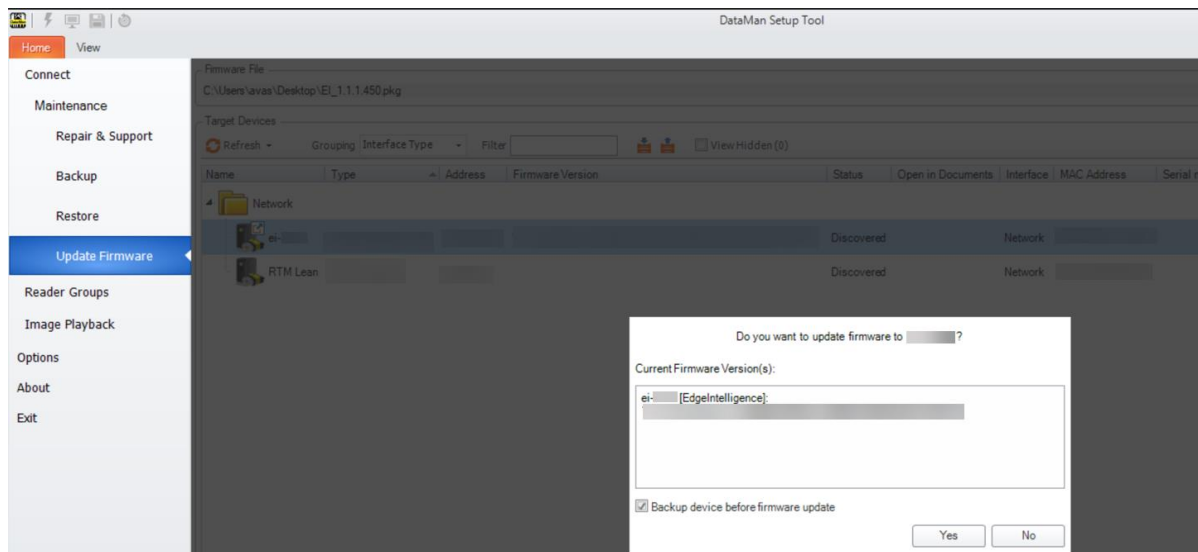

Note: Creating a backup by selecting the checkbox is optional.

8. Wait until the update procedure is complete then click **Close**.

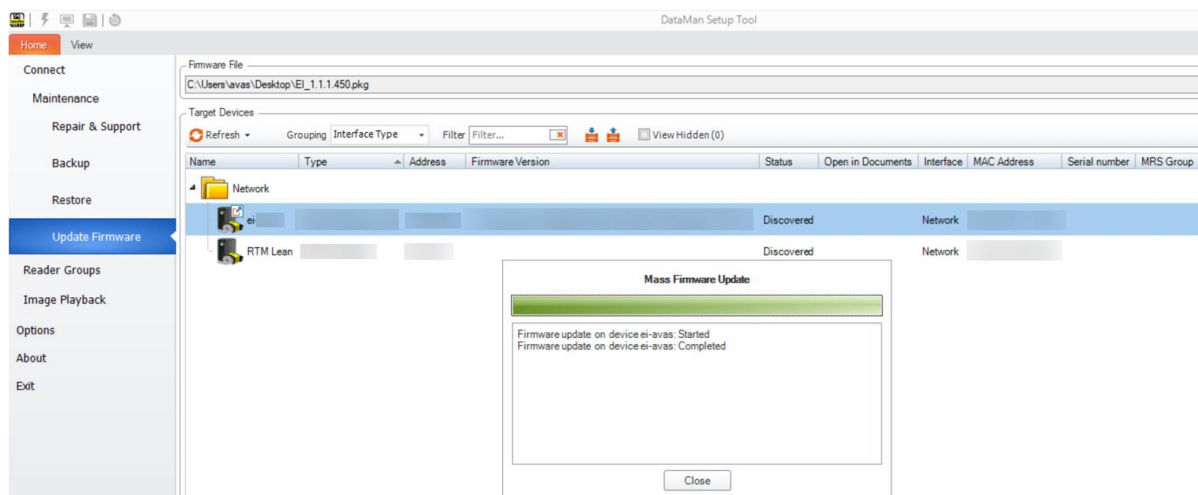

Open Source Licenses

The table below shows the open source licenses used by EI Station Manager:

@amcharts/amcharts3-angular	Paid
angular-resize-event	MIT
angular2-moment	MIT
core-js	MIT
dateformat	MIT
daterangepicker	MIT
fullscreen	MIT
moment	MIT
ngx-daterangepicker-material	MIT
ngx-spinner	MIT
primeicons	MIT
rxjs	Apache-2.0
rxjs-compat	Apache-2.0
screenfull	MIT
socket.io	MIT
socket.io-client	MIT
Timescaledb	Apache-2.0
Timescale toolkit	Timescale License
zone.js	MIT

