

COGNEX

SLX[®] 280D Series

Quick Reference Guide



2025 October 17
Revision: 25.2.0.9

Precautions

To reduce the risk of injury or equipment damage, observe the following precautions when you install the Cognex product:

- The safety of any system incorporating this product is the responsibility of the assembler of the system.
- Do not install Cognex products where they are exposed to environmental hazards such as excessive heat, dust, moisture, humidity, impact, vibration, corrosive substances, flammable substances, or static electricity.
- Route cables and wires away from high-current wiring or high-voltage power sources to reduce the risk of damage or malfunction from the following causes: over-voltage, line noise, electrostatic discharge (ESD), power surges, or other irregularities in the power supply.
- Do not expose the image sensor to laser light. Image sensors can be damaged by direct, or reflected, laser light. If your application requires laser light that might strike the image sensor, use a lens filter at the corresponding laser wavelength. For suggestions, contact your local integrator or application engineer.

- This product does not contain user-serviceable parts. Do not make electrical or mechanical modifications to product components. Unauthorized modifications can void your warranty.
- Changes or modifications not expressly approved by the party responsible for regulatory compliance could void the user's authority to operate the equipment.
- Include service loops with cable connections.
- Ensure that the cable bend radius begins at least six inches from the connector. Cable shielding can be degraded or cables can be damaged or wear out faster if a service loop or bend radius is tighter than 10X the cable diameter.
- This device should be used in accordance with the instructions in this manual.
- All specifications are for reference purposes only and can change without notice.

Symbols

The following symbols indicate safety precautions and supplemental information:

 **WARNING:** This symbol indicates a hazard that could cause death, serious personal injury or electrical shock.

 **CAUTION:** This symbol indicates a hazard that could result in property damage.



 **Note:** This symbol indicates additional information about a subject.

 **Tip:** This symbol indicates suggestions and shortcuts that might not otherwise be apparent.

Accessories

You can purchase the following components separately. For a list of options and accessories, contact your local Cognex sales representative.

Mounting Brackets

Accessory	Product Number	Illustration
Pivot mounting bracket	DM100-PIVOTM-01	
Logistics mounting bracket and plate kit	DMA-BKT-LGS	



Miscellaneous Accessories







Accessory	Product Number
Photoeye Kit	LST-PHOTOEYE-02



Accessory	Product Number
Diffuse Photoeye Kit	LST-PHOTOEYE-DFE
Encoder, RH-P240AJ/8-30 RC MW1-UB3-10M	LST-ENCODER-000
Buzzer with Red LED	LGM-BUZZER-RED

Cognex I/O Accessories

i **Note:** For more information on Cognex I/O system, see the *Cognex I/O User Guide*.

Accessory	Product Number	Illustration
Emparero Power Supply 8A 7/8" - L	CPS-4A-78-L	
Emparero Input 7/8" to C14 (length: 2 m)	CCB-CPS-A3E11-200	

Accessory	Product Number	Illustration
Two-Channel Emparro Output L-Coded (length: 1 m)	CCB-CPS-344533-100	
Power chain L-coded cable (length: 2 m, 5 m)	CCB-CIO-P4141-200	
	CCB-CIO-P4141-500	
Power Breakout Box	CIO-PB-4	
External/Light Connector cable (length: 2 m, 5 m)	CCB-CIO-40021-200	
	CCB-CIO-40021-500	
M12 Cable T-Splitter	CCB-CIO-42751-000	

Accessory	Product Number	Illustration
Shielded Secondary Cable 4-pin (length: 2 m, 5 m, 10 m)	CCB-CIO-40507-200	
	CCB-CIO-40507-500	
	CCB-CIO-40507-1000	
Master Breakout Box, PNP	CIO-MB-PNP	
Primary Cable 12-pin (length: 2 m)	CCB-CIO-53001-200	
RJ45 to RJ45, RA, IP67 (length: 2 m)	CCB-ETH-RJ45-2RA	

Accessory	Product Number	Illustration
Ethernet chain X-coded cable (length: 1 m, 2 m, 5 m, 10 m)	CCB-CIO-51001-100	
	CCB-CIO-51001-200	
	CCB-CIO-51001-500	
	CCB-CIO-51001-1000	

SLX-280D Systems

	Omnidirectional 1D Codes	1D Max with Hotbars	2DMax - Hard to Read 2D Codes	Power Grid - Damaged 2D Codes	High Speed Decoding	Edge Learning Classifier	Vision and Barcode Reading Tools	Dual Ethernet Ports	Resolution
SLX-280D-M4C	✓	✓	✓		✓			✓	1440 x 1080

	Omnidirectional 1D Codes	1D Max with Hotbars	2D Max - Hard to Read 2D Codes	Power Grid - Damaged 2D Codes	High Speed Decoding	Edge Learning Classifier	Vision and Barcode Reading Tools	Dual Ethernet Ports	Resolution
SLX-280-D-M4H	✓	✓	✓		✓	✓	✓	✓	1440 x 1080

Setting Up Your SLX-280D Device

Read this section to learn how the device connects to its standard components and accessories.

Note:

- Cables are sold separately.
- If a standard component is missing or damaged, immediately contact your Cognex Authorized Service Provider (ASP) or Cognex Technical Support.

 **CAUTION:** All cable connectors are keyed to fit the connectors on the device. Do not force the connections or damage may occur.

SLX-280D Layout

The image and table below shows the elements of the device.

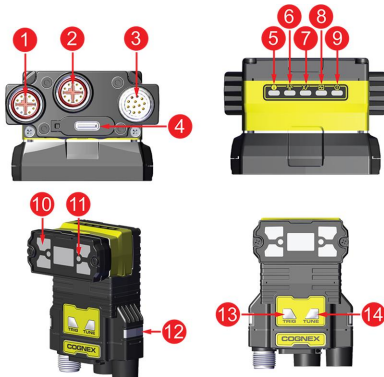

Number	Description
1	Ethernet connector 1
2	Ethernet connector 2
3	Power I/O Breakout cable connector
4	USB-C slot (with plastic cover)
5	Error LED indicator
6	Communication LED indicator

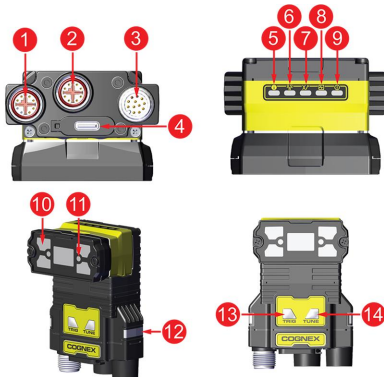

Number	Description
7	Good/bad read LED indicator
8	Train/Trigger status LED indicator
9	Power LED indicator
10	Illumination LEDs
11	LED aimer
12	Indicator LEDs

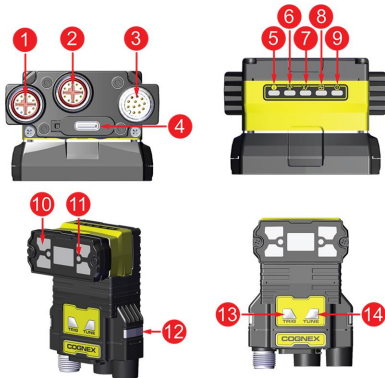

Number	Description
13	Trigger button (not supported)
14	Tune button (not supported)

Dimensions

The following sections list dimensions of the device.

Note:

- Dimensions are in millimeters and are for reference purposes only.
- All specifications are for reference purposes only and can change without notice.

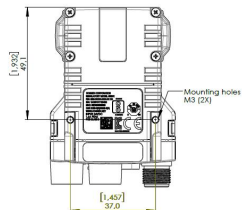
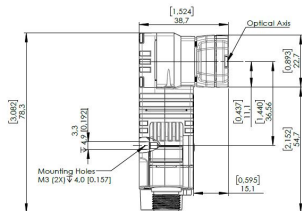
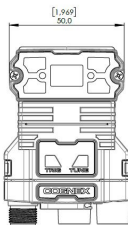
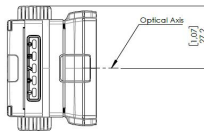
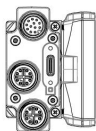

Field of View and Working Distance

This section provides the Field of View (FoV) values for 4.5 mm lenses.

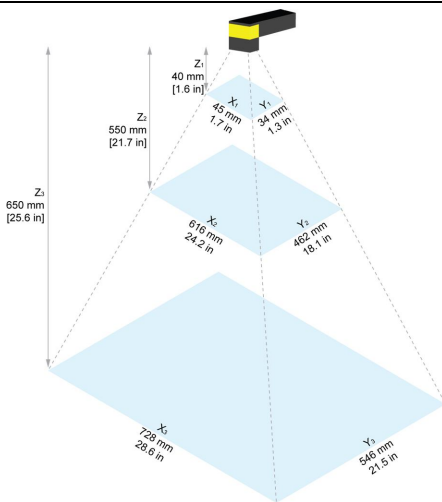

Working Distance	Horizontal Values	Vertical Values
$Z_1 = 40 \text{ mm}$ [1.6 in]	$X_1 = 45 \text{ mm}$ [1.7 in]	$Y_1 = 34 \text{ mm}$ [1.3 in]

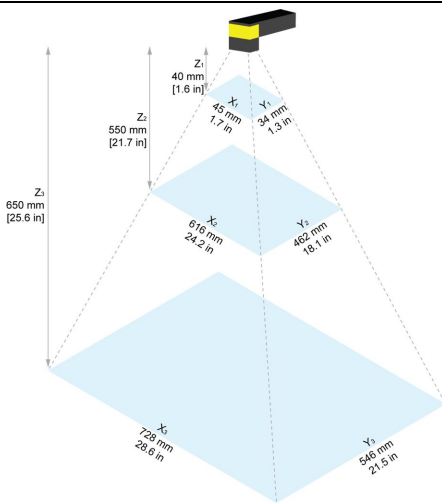

$Z_2 = 550 \text{ mm [21.7 in]}$	$X_2 = 616 \text{ mm [24.2 in]}$	$Y_2 = 462 \text{ mm [18.1 in]}$
$Z_3 = 650 \text{ mm [25.6 in]}$	$X_3 = 728 \text{ mm [28.6 in]}$	$Y_3 = 546 \text{ mm [21.5 in]}$

Distances in mm	2D min. Code in mil	1D min. Code in mil
400 mm [15.7 in]	18	12

Distances in mm	2D min. Code in mil	1D min. Code in mil
500 mm [19.7 in]	20	15
650 mm [25.6 in]	30	20

Mounting the Device

The device provides mounting holes for attachment to a mounting surface.

CAUTION: The device has to be grounded, either by mounting the device to a fixture that is electrically grounded or by attaching a wire from the mounting fixture of the device to frame ground or Earth ground. If a ground wire is used, it has to be attached to one of the four mounting points on the bottom plate of the device and not to the mounting points on the front of the device.



Align the holes on the mounting surface with the mounting holes on the device. With the reader in right-angle position, only the back mounting holes can be used.

Note:

Mounting the device at a slight angle (15°) reduces reflections and improves performance.

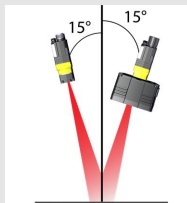

Connecting the Ethernet Cable

CAUTION: The Ethernet cable shield has to be grounded at the far end.

 If the far end device is not grounded, add a ground wire in compliance with local electrical codes. The cable is typically plugged into a switch or router, which has to have a grounded Ethernet connector. Use a digital voltmeter to validate the grounding.

1. Connect the M12 connector of the Ethernet cable to the device ENET connector.
2. Connect the RJ-45 connector of the Ethernet cable to a switch/router or PC, as applicable.

Connecting the Ethernet Cable to the SLX-280D

Connect the network cable to any Ethernet connector of the SLX-280D:

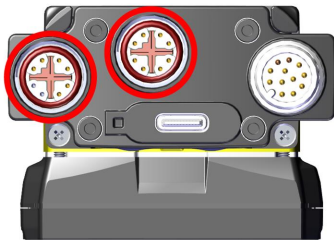

The SLX-280D provides two 100 MBit Ethernet ports in a single physical connector. Both ports are connected internally within the device and support the same network functionality. The ports are individually identifiable through MAC addressing, but share a common IP address. This allow daisy chaining of multiple readers together.

Star Network Topology

The star topology connects each device to the PLC individually. This topology offers increased availability, as each device can be reached individually.

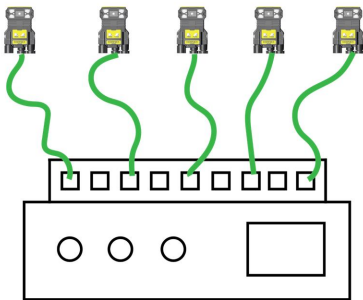

Line Network Topology

The line topology connects the devices in daisy chain. The Ethernet output of one device is plugged into the Ethernet input of the next device. The line starts at the output from the PLC, and ends at the input connector of the last device. This topology reduces the cabling needed to connect all devices.

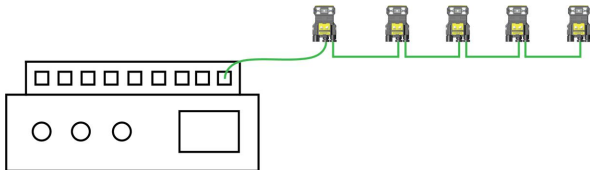

Connecting the Power and I/O Breakout Cable

 **CAUTION:** To reduce emissions, connect the far end of the Breakout cable shield to frame ground.

Note:

-  Perform wiring or adjustments to I/O devices when the device is not receiving power.
- You can clip unused wires short or use a tie made of non-conductive material to tie them back. Keep bare wires separated from the +24 V DC wire.

1. Verify that the 24 V DC power supply is unplugged and not receiving power.
2. Attach the +24 V DC connector of the Power and I/O Breakout cable and Ground wires to the corresponding terminals on the power supply. For more information, see Specifications.

3. Attach the M12 connector of the Power and I/O Breakout Cable to the 24 V DC connector of the device.
4. Restore power to the 24 V DC power supply and turn it on if necessary.

Using your Device through USB

You can use the USB connector of the SLX-280D for emulating Ethernet functionality.

For a detailed description, see the SLX-280D Reference Manual.

 **Note:** To prevent issues, ensure that the USB connector is tightly screwed on.

Specifications

The following sections list general specifications for the device.

SLX-280D Device

Specification	SLX-280D
Weight	350 g
Power	24 V DC +/- 10% With USB-C cable: 4.75 – 5.25 V  Note: Do not power the device through USB in a production environment.
Power Consumption	≤ 7.5 W

Specification	SLX-280D
24 V Supply	24 V DC \pm 10% LPS or NEC class 2
	Power consumption without USB device attached: <ul style="list-style-type: none"> • Average \leq 5 W using High-Powered Light • Average \leq 6 W using High Frequency High-Powered Light • Peak \leq 1.6 A using internal illumination
Power over Ethernet Supply	N/A
Operating Temperature	0–40°C (32–104°F)
Storage Temperature	-10–60°C (14–140°F)
Humidity	<95% non-condensing

Specification	SLX-280D
Environmental	<p data-bbox="260 138 972 174">IP67, Altitude: 2000 m, indoor use only, pollution degree II</p> <div data-bbox="260 192 972 370" style="border: 1px solid black; padding: 5px;"> <p data-bbox="260 211 972 350">Note: IP67 rating applies only if all blind plugs and cables are attached properly, or the provided connector plug is installed. Also, make sure that the IP67-rated cover is installed properly.</p> </div>
Shock	IEC 60068-2-27 - 500 shocks in each polarity of each (X, Y, and Z) axis, 3000 shocks total, semi-sinusoidal, 11 g, 10 ms
Shock (Shipping and Storage)	ISTA-1A Standardized Testing - Packaged Products 150 lb or less
Vibration	IEC 60068-2-6: vibration test in each of the three main axis for 2 hours @ 10 Gs (10 to 500 Hz at 100m/s ² / 15 mm)
Vibration (Shipping and Storage)	FedEx Vibration Testing for packaged products 150 lbs or less

Specification	SLX-280D
Codes	<p>1-D barcodes: Codabar, Code 25, Code 39, Code 128, Code 93, UPC/EAN/JAN, MSI</p> <p>2-D barcodes: Data Matrix, QR Code, DotCode</p>
Job Program and Image Storage Memory	380 MB

SLX-280D Device Image Sensor

Specification	SLX-280D
Image Sensor	1/3-inch CMOS, global shutter
Image Sensor Properties	<p>Diagonal size: 6.21 mm</p> <p>Pixel size: 3.45 μm (H) x 3.45 μm (V)</p>
Image Resolution (pixels)	1440 x 1080 (1.6 MP)
Electronic Shutter Speed	<p>Minimum exposure: 29 μs</p> <p>Maximum exposure: 10 ms (with external illumination)</p>

Specification	SLX-280D
Image Acquisition at Full Resolution	Maximum: 45 Hz
Lens Type	

Regulations and Conformity

Note: For the most current CE and UKCA declaration and regulatory conformity information, see the Cognex support site:
cognex.com/support.

SLX-280D devices have Regulatory Model number 50214 and meet or exceed the requirements of all applicable standards organizations for safe operation. However, as with any electrical equipment, the best way to ensure safe operation is to operate them according to the agency guidelines that follow. Please read these guidelines carefully before using your device.

Safety and Regulatory	
Manufacturer	Cognex Corporation One Vision Drive Natick, MA 01760 USA

Safety and Regulatory

CE

SLX-280D L-Shaped: Regulatory Model 50214
This is a class A product. In a domestic environment this product may cause radio interference in which case the user may be required to take immediate measures. This equipment complies with the essential requirements of the EU Directive 2014/30/EU. Declarations are available from your local representative.

EU RoHS

Compliant to the most recent applicable directive.

Safety and Regulatory

FCC	<p>FCC Part 15, Class A</p> <p>This equipment has been tested and found to comply with the limits for a Class A digital device, pursuant to part 15 of the FCC Rules. These limits are designed to provide reasonable protection against harmful interference when the equipment is operated in a commercial environment. This equipment generates, uses, and can radiate radio frequency energy and, if not installed and used in accordance with the instruction manual, may cause harmful interference to radio communications. Operation of this equipment in a residential area is likely to cause harmful interference in which case the user will be required to correct the interference at his own expense.</p>
Korea 	<p>This device is certified for office use only and if used at home, there can be frequency interference problems.</p> <p>A급 기기(업무용 방송통신기자재): 이 기기는 업무용 (A급) 전자파적합기기로서 판매자 또는 사용자는 이 점을 주의하시기 바라며, 가정외의 지역에서 사용하는 것을 목적으로 합니다.</p> <p>SLX-280D L-Shaped: R-R-CGX-50214</p>

Safety and Regulatory

TÜV	SLX-280D L-Shaped: Regulatory Model 50214
	NRTL: TÜV SÜD SCC/NRTL OSHA Scheme for UL/CAN 61010-1.
	CB report available upon request. TÜV SÜD, IEC/EN 61010-1.
UK CA	SLX-280D L-Shaped: Regulatory Model 50214 This is a class A product. In a domestic environment this product may cause radio interference in which case the user may be required to take immediate measures. This equipment complies with the essential requirements of the Electromagnetic Compatibility Regulations 2016. Declarations are available from your local representative.

中国大陆RoHS (Information for China RoHS Compliance)

根据中国大陆《电子信息产品污染控制管理办法》(也称为中国大陆RoHS), 以下部份列出了本产品中可能包含的有毒有害物质或元素的名称和含量。



	Hazardous Substances 有害物质					
Part Name 部件名称	Lead (Pb) 铅	Mercury (Hg) 汞	Cadmium (Cd) 镉	Hexavalent Chromium (Cr (VI)) 六价铬	Polybrominated biphenyls (PBB) 多溴联苯	Polybrominated diphenyl ethers (PBDE) 多溴二苯醚
Regulatory Model 50214	X	O	O	O	O	O

This table is prepared in accordance with the provisions of SJ/T 11364.

这个标签是根据SJ/T 11364 的规定准备的。

O: Indicates that said hazardous substance contained in all of the homogeneous materials for this part is below the limit requirement of GB / T26572 - 2011.

表示本部件所有均质材料中含有的有害物质低于GB / T26572 - 2011 的限量要求。

X: Indicates that said hazardous substance contained in at least one of the homogeneous materials used for this part is above the limit requirement of GB / T26572 - 2011.

表示用于本部件的至少一种均质材料中所含的危害物质超过GB / T26572 - 2011 的限制要求。

For European Community Users

Cognex complies with Directive 2012/19/EU OF THE EUROPEAN PARLIAMENT AND OF THE COUNCIL of 4 July 2012 on waste electrical and electronic equipment (WEEE).

This product has required the extraction and use of natural resources for its production. It may contain hazardous substances that could impact health and the environment, if not properly disposed.

In order to avoid the dissemination of those substances in our environment and to diminish the pressure on the natural resources, we encourage you to use the appropriate take-back systems for product disposal. Those systems will reuse or recycle most of the materials of the product you are disposing in a sound way.



The crossed out wheeled bin symbol informs you that the product should not be disposed of along with municipal waste and invites you to use the appropriate separate take-back systems for product disposal.

If you need more information on the collection, reuse, and recycling systems, please contact your local or regional waste administration.

You may also contact your supplier for more information on the environmental performance of this product.

Copyright © 2025
Cognex Corporation. All Rights Reserved.