

# In-Sight<sup>®</sup> 9000 Series Vision System Reference Guide



2019 May 07  
Revision: 5.7.1.5

# Legal Notices

The software described in this document is furnished under license, and may be used or copied only in accordance with the terms of such license and with the inclusion of the copyright notice shown on this page. Neither the software, this document, nor any copies thereof may be provided to, or otherwise made available to, anyone other than the licensee. Title to, and ownership of, this software remains with Cognex Corporation or its licensor. Cognex Corporation assumes no responsibility for the use or reliability of its software on equipment that is not supplied by Cognex Corporation. Cognex Corporation makes no warranties, either express or implied, regarding the described software, its merchantability, non-infringement or its fitness for any particular purpose.

The information in this document is subject to change without notice and should not be construed as a commitment by Cognex Corporation. Cognex Corporation is not responsible for any errors that may be present in either this document or the associated software.

Companies, names, and data used in examples herein are fictitious unless otherwise noted. No part of this document may be reproduced or transmitted in any form or by any means, electronic or mechanical, for any purpose, nor transferred to any other media or language without the written permission of Cognex Corporation.

Copyright © 2018. Cognex Corporation. All Rights Reserved.

Portions of the hardware and software provided by Cognex may be covered by one or more U.S. and foreign patents, as well as pending U.S. and foreign patents listed on the Cognex web site at: [cognex.com/patents](http://cognex.com/patents).

---

The following are registered trademarks of Cognex Corporation:

Cognex, 2DMAX, Advantage, AlignPlus, Assemblyplus, Check it with Checker, Checker, Cognex Vision for Industry, Cognex VSOC, CVL, DataMan, DisplayInspect, DVT, EasyBuilder, Hotbars, IDMax, In-Sight, Laser Killer, MVS-8000, OmniView, PatFind, PatFlex, PatInspect, PatMax, PatQuick, SensorView, SmartView, SmartAdvisor, SmartLearn, UltraLight, Vision Solutions, VisionPro, VisionView

The following are trademarks of Cognex Corporation:

The Cognex logo, 1DMax, 3D-Locate, 3DMax, BGAll, CheckPoint, Cognex VSoC, CVC-1000, FFD, iLearn, In-Sight (design insignia with cross-hairs), In-Sight 2000, InspectEdge, Inspection Designer, MVS, NotchMax, OCRMax, PatMax RedLine, ProofRead, SmartSync, ProfilePlus, SmartDisplay, SmartSystem, SMD4, VisiFlex, Xpand



Portions copyright © Microsoft Corporation. All rights reserved.

Portions copyright © MadCap Software, Inc. All rights reserved.

Other product and company trademarks identified herein are the trademarks of their respective owners.

# Regulations and Conformity

**Note:** For the most current CE declaration and regulatory conformity information, see the Cognex support site: [cognex.com/support](http://cognex.com/support).

Safety and Regulatory	
Manufacturer	Cognex Corporation One Vision Drive Natick, MA 01760 USA
	In-Sight 9902L: Regulatory Model 1AA9 In-Sight 9912/9912C: Regulatory Model R00064 This is a class A product. In a domestic environment this product may cause radio interference in which case the user may be required to take immediate measures. This equipment complies with the essential requirements of the EU Directive 2014/30/EU. Declarations are available from your local representative.
EU RoHS	Compliant to the most recent applicable directive.
FCC	FCC Part 15, Class A This equipment has been tested and found to comply with the limits for a Class A digital device, pursuant to part 15 of the FCC Rules. These limits are designed to provide reasonable protection against harmful interference when the equipment is operated in a commercial environment. This equipment generates, uses, and can radiate radio frequency energy and, if not installed and used in accordance with the instruction manual, may cause harmful interference to radio communications. Operation of this equipment in a residential area is likely to cause harmful interference in which case the user will be required to correct the interference at his own expense.
Korea 	In-Sight 9902L: Regulatory Model 1AA9: R-REM-CGX-1AA9 In-Sight 9912/9912C: Regulatory Model R00064: R-R-CGX-R00064 This device is certified for office use only and if used at home, there can be frequency interference problems.
NRTL	TÜV SÜD AM SCC/NRTL OSHA Scheme for UL/CAN 61010-1.
CB	TÜV SÜD AM, IEC/EN 61010-1. CB report available upon request.

## China RoHS



Part Name 部件名称	Hazardous Substances 有害物质					
	Lead (Pb) 铅	Mercury (Hg) 汞	Cadmium (Cd) 镉	Hexavalent Chromium (Cr (VI)) 六价铬	Polybrominated biphenyls (PBB) 多溴联苯	Polybrominated diphenyl ethers (PBDE) 多溴二苯醚
Regulatory Model 1AA9 Regulatory Model R00064	X	O	O	O	O	O

This table is prepared in accordance with the provisions of SJ/T 11364.  
这个标签是根据SJ/T 11364 的规定准备的。

O: Indicates that said hazardous substance contained in all of the homogeneous materials for this part is below the limit requirement of GB / T26572 - 2011.  
表示本部件所有均质材料中含有的有害物质低于GB / T26572 - 2011 的限量要求。

X: Indicates that said hazardous substance contained in at least one of the homogeneous materials used for this part is above the limit requirement of GB / T26572 - 2011.  
表示用于本部件的至少一种均质材料中所含的危害物质超过GB / T26572 - 2011 的限制要求。

## For European Community Users

Cognex complies with Directive 2012/19/EU OF THE EUROPEAN PARLIAMENT AND OF THE COUNCIL of 4 July 2012 on waste electrical and electronic equipment (WEEE).

This product has required the extraction and use of natural resources for its production. It may contain hazardous substances that could impact health and the environment, if not properly disposed.

In order to avoid the dissemination of those substances in our environment and to diminish the pressure on the natural resources, we encourage you to use the appropriate take-back systems for product disposal. Those systems will reuse or recycle most of the materials of the product you are disposing in a sound way.



The crossed out wheeled bin symbol informs you that the product should not be disposed of along with municipal waste and invites you to use the appropriate separate take-back systems for product disposal.

If you need more information on the collection, reuse, and recycling systems, please contact your local or regional waste administration.

You may also contact your supplier for more information on the environmental performance of this product.

# Precautions

To reduce the risk of injury or equipment damage when you install the Cognex product, observe the following precautions:

- The vision system requires a UL or NRTL listed power supply with a 24VDC output and meets the following rating requirements:
  - At least 2A continuous current.
  - A maximum short circuit current of less than 8A.
  - A maximum power of less than 100VA and marked as a Limited Power Source (LPS) or National Electrical Code (NEC) Class 2.

Any other voltage creates a risk of fire or shock and can damage the components. Applicable national and local wiring standards and rules must be followed.

- Route cables and wires away from high-current wiring or high-voltage power sources to reduce the risk of damage or malfunction from the following causes: over-voltage, line noise, electrostatic discharge (ESD), power surges, or other irregularities in the power supply.
- Do not install Cognex products where they are exposed to environmental hazards such as excessive heat, dust, moisture, humidity, impact, vibration, corrosive substances, flammable substances, or static electricity.
- Do not expose the image sensor to laser light. Image sensors can be damaged by direct, or reflected, laser light. If your application requires laser light that might strike the image sensor, use a lens filter at the corresponding laser wavelength. For suggestions, contact your local integrator or application engineer.
- Changes or modifications not expressly approved by the party responsible for regulatory compliance could void the user's authority to operate the equipment.
- Include service loops with cable connections.
- Ensure that the cable bend radius begins at least six inches from the connector. Cable shielding can be degraded or cables can be damaged or wear out faster if a service loop or bend radius is tighter than 10X the cable diameter.
- In-Sight 9902L line scan vision system's external LIGHT connector is not supported.
- This device should be used in accordance with the instructions in this manual.
- All specifications are for reference purposes only and can change without notice.

# Table of Contents

<b>Legal Notices</b> .....	<b>2</b>
<b>Regulations and Conformity</b> .....	<b>3</b>
China RoHS .....	4
For European Community Users .....	4
<b>Precautions</b> .....	<b>5</b>
<b>Table of Contents</b> .....	<b>6</b>
<b>Symbols</b> .....	<b>8</b>
<b>Introduction</b> .....	<b>9</b>
Support .....	9
Standard Components .....	9
Accessories .....	10
C-Mount Covers .....	10
Cables .....	10
External Lights .....	12
I/O Modules .....	14
Connectors and Indicators .....	15
<b>Installation</b> .....	<b>17</b>
Install the C-Mount Lens and Cover (COV-7000-CMNT-LG) .....	17
Mount the Vision System .....	18
Connect the External Light Cable (9912 Only) .....	19
Connect the Ethernet Cable .....	20
Connect the Breakout Cable .....	21
Replace the SD Card (Optional) .....	22
Connect the CIO-MICRO I/O Module (Optional) .....	23
Connect the CIO-1400 I/O Expansion Module (Optional) .....	26
<b>Specifications</b> .....	<b>28</b>
9902L Vision System Specifications .....	28
9912 Vision System Specifications .....	30
Acquisition Trigger Input .....	32
9902L Encoder Inputs .....	33
9902L Encoder Input Wiring .....	33
General-Purpose Inputs .....	34
High-Speed Outputs .....	35
High-Speed Output Wiring .....	36
External Light Connector .....	37
Ethernet Cable .....	38
Breakout Cable .....	39
I/O Module Cable .....	40
Dimensions .....	41
9902L Vision System Dimensions .....	41
9902L Vision System with Cover (COV-7000-CMNT-LG) .....	42
9902L Vision System with Cover (COV-7000-CMNT-LG) and Extender (COV-7000-CMNT-LGX) .....	43
9902L C-Mount Lens Clearance Dimensions .....	44
9912 Vision System Dimensions .....	45

9912 Vision System with Cover (COV-7000-CMNT-LG) .....46

9912 Vision System with Cover (COV-7000-CMNT-LG) and Extender (COV-7000-CMNT-LGX) ..... 47

**Cleaning and Maintenance ..... 48**

    Clean the Housing .....48

    Clean the Image Sensor Window ..... 48

    Clean the Cover ..... 48

# Symbols

The following symbols indicate safety precautions and supplemental information:

---

 **WARNING:** This symbol indicates a hazard that could cause death, serious personal injury or electrical shock.

---

---

 **CAUTION:** This symbol indicates a hazard that could result in property damage.

---

---

 **Note:** This symbol indicates additional information about a subject.

---

---

 **Tip:** This symbol indicates suggestions and shortcuts that might not otherwise be apparent.

---

# Introduction

The In-Sight<sup>®</sup> vision system is a compact, network-ready, stand-alone machine vision system used for automated inspection, measurement, identification and robot guidance applications on the factory floor. All models can be easily configured remotely over a network using an intuitive user interface.

## Support

Many information resources are available to help you use the vision system:

- The *In-Sight<sup>®</sup> Explorer Help* and *EasyBuilder Help* files, provided with In-Sight Explorer software.
- On-demand training: [cognex.com/on-demand-training.aspx](http://cognex.com/on-demand-training.aspx).
- The In-Sight online support site: [cognex.com/support/insight](http://cognex.com/support/insight).

## Standard Components

**Note:**



- Cables are sold separately.
- If a standard component is missing or damaged, immediately contact your Cognex Authorized Service Provider (ASP) or Cognex Technical Support.



Component	Description
Vision System	Provides image acquisition, vision processing, job storage, Ethernet connectivity and discrete I/O. The vision system has an 8GB SD card pre-installed.



## Accessories

You can purchase the following components separately. For a list of options and accessories, contact your local Cognex sales representative.

### C-Mount Covers

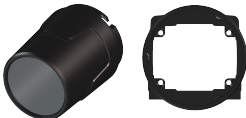

**Note:**



- For the In-Sight 9902L vision system, the C-Mount lens has the following restrictions:
  - Maximum thread length is 5.25mm.
  - The C-Mount lens threads and body cannot protrude more than 6.5mm in length into the vision system when screwed in, unless the diameter of the back lens is smaller than 19.25mm. If the C-Mount lens threads and body protrude more than 6.5mm, you can add a spacer between the lens and vision system. However, the spacer decreases the working distance.
- Refer to [9902L C-Mount Lens Clearance Dimensions on page 44](#) for more information.

C-Mount Covers	Part Number	
Large C-Mount cover and adapter. <b>Note:</b> If using the COV-7000-CMNT-LG cover with the In-Sight 9902L vision system, the maximum lens length is 77mm, the maximum lens body diameter is 55mm and the maximum diameter including locking screws is 55mm.	COV-7000-CMNT-LG	
30mm C-Mount cover extender	COV-7000-CMNT-LGX	

### Cables

**Note:** The External Light cable is not supported with the In-Sight 9902L line scan vision system.

Cables	Part Number	
Breakout Cable, M12-12 to Flying Lead	CCB-PWRIO- xx (straight, xx specifies length: 5m, 10m, 15m)	
Breakout Cable, M12-12 to Flying Lead	CCB-PWRIO-xxR (right-angled, xx specifies length: 5m, 10m, 15m)	
Ethernet X-coded M12-8 to RJ-45 Cable	CCB-84901-2001-xx (straight, xx specifies length: 2m, 5m, 10m, 15m, 30m)	
Ethernet X-coded M12-8 to RJ-45 Cable	CCB-84901-2002 (right-angled, xx specifies length: 2m, 5m, 10m)	

Cables	Part Number	
External Light Cable, Grey <b>Note:</b> The External Light cable CCB-M12LTF-xx does not support intensity control.	CCB-M12LTF-xx (xx specifies length: 0.5m, 1m, 2m, 5m)	
External Light Cable, Yellow	IVSL-5PM12-J300 IVSL-5PM12-J500 IVSL-5PM12-J1000 IVSL-5PM12-J2000	
External Light Cable, Black	IVSL-M12-NSB-300 IVSL-M12-NSB-1000 IVSL-M12-NSB-2000	
I/O Module Cable M12-12 to DB15	CCB-PWRIO-MOD-xx (xx specifies length: 2m, 5m)	

## External Lights





External lights can be connected to the vision system's LIGHT connector using the External Light cable.

**Note:**

- External lights are not supported for the In-Sight 9902L line scan vision system.
- If interference from Electrical Fast Transient (EFT) is experienced under extreme factory conditions, a Fair-Rite ferrite (part number 0431176451) should be added as close to the vision system as practical, with the External Light cable looped through it. For example:

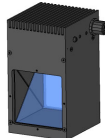

- If daisy-chaining multiple Cognex IVSL-YLW2X-xxx or IVSL-YLW300-xxx external lights:
  - The lights must be powered externally by a separate power supply.
  - A Cognex control cable (CCB-FOV25-MAL-012) can be used to connect the vision system's LIGHT connector to the external light and a Cognex power cable (IVSL-5PM12-5) can be used to connect the light to the separate power supply. Only the power and ground wires from the Cognex power cable (IVSL-5PM12-5) should be connected to the remote power supply.
- If using a Cognex IVSL-LX520-xxx external light:
  - The lights must be powered externally by a separate power supply.
  - A Cognex control cable (CCB-FOV25-MAL-012) can be used to connect the vision system's LIGHT connector to the external light and a Cognex power cable (IVSL-5PM12-5) can be used to connect the light to the separate power supply. Only the power and ground wires from the Cognex power cable (IVSL-5PM12-5) should be connected to the remote power supply.
  - The following cables must not be used with IVSL-LX520-xxx external lights: IVSL-5PM12-J300, IVSL-5PM12-J500 and IVS-5PM12-J1000, IVSL-5PM12-J2000.
- The In-Sight 9912 vision systems supports Cognex IVSL-YL300-xx external lights with the following External Light cables: IVSL-M12-NSB-300, IVSL-M12-NSB-1000 and IVSL-M12-NSB-2000.

External Lights	Part Number	Supported External Light Cables	
Ring light	CLRR-R7030G1CLR	CCB-M12LTF-xx	
Back light	CLRB-F100100G1	CCB-M12LTF-xx	
Coaxial Dual on Access Light (DOAL)	CLRO-K5050G1	CCB-M12LTF-xx	
Spot light	CLRS-P14G1	CCB-M12LTF-xx	

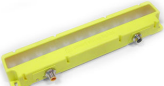
External Lights	Part Number	Supported External Light Cables	
Dark-field light	CLRD-D120G1	CCB-M12LTF-xx	
Brick light, narrow blue	IVSL-ODDM-S75-470	IVSL-5PM12-J300 IVSL-5PM12-J500 IVSL-5PM12-J1000 IVSL-5PM12-J2000	
Brick light, narrow red	IVSL-ODDM-S75-625	IVSL-5PM12-J300 IVSL-5PM12-J500 IVSL-5PM12-J1000 IVSL-5PM12-J2000	
Bar light, wide red	IVSL-YLW2X-625	IVSL-5PM12-J300 IVSL-5PM12-J500 IVSL-5PM12-J1000 IVSL-5PM12-J2000	
Bar light, narrow red, linear polarizer	IVSL-YLW2X-625P	IVSL-5PM12-J300 IVSL-5PM12-J500 IVSL-5PM12-J1000 IVSL-5PM12-J2000	
Bar light, narrow infrared	IVSL-YLW2X-850	IVSL-5PM12-J300 IVSL-5PM12-J500 IVSL-5PM12-J1000 IVSL-5PM12-J2000	
Bar light, narrow blue	IVSL-YLW300-470	IVSL-5PM12-J300 IVSL-5PM12-J500 IVSL-5PM12-J1000 IVSL-5PM12-J2000	
Bar light, wide blue	IVSL-YLW300-470 W	IVSL-5PM12-J300 IVSL-5PM12-J500 IVSL-5PM12-J1000 IVSL-5PM12-J2000	
Bar light, narrow red	IVSL-YLW300-625	IVSL-5PM12-J300 IVSL-5PM12-J500 IVSL-5PM12-J1000 IVSL-5PM12-J2000	
Bar light, wide red	IVSL-YLW300-625 W	IVSL-5PM12-J300 IVSL-5PM12-J500 IVSL-5PM12-J1000 IVSL-5PM12-J2000	
Bar light, narrow white	IVSL-YLW300-WHI	IVSL-5PM12-J300 IVSL-5PM12-J500 IVSL-5PM12-J1000 IVSL-5PM12-J2000	
Bar light, wide white	IVSL-YLW300-WHI W	IVSL-5PM12-J300 IVSL-5PM12-J500 IVSL-5PM12-J1000 IVSL-5PM12-J2000	
Bar light, blue	IVSL-LX520-470	CCB-FOV25-MAL-012 for intensity and strobe control. IVSL-5PM12-5 for power.	
Bar light, red	IVSL-LX520-625	CCB-FOV25-MAL-012 for intensity and strobe control. IVSL-5PM12-5 for power.	

## I/O Modules

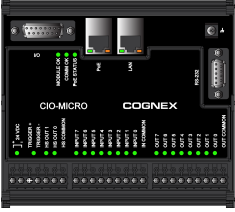
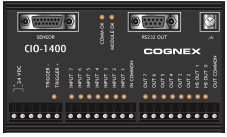
I/O Modules	Part Number	
In-Sight CIO-MICRO I/O Module	CIO-MICRO-00	 <p>The image shows the Cognex CIO-MICRO I/O module. It is a black printed circuit board with various connectors and components. The top left features a D-sub connector labeled 'IO'. Below it are several status LEDs and labels for 'MODBUS/RS-485', 'PZ', and 'DM'. The center of the board has the 'CIO-MICRO' and 'COGNEX' branding. The bottom edge is populated with a series of pins, with labels for 'IN 1' through 'IN 16' and 'OUT 1' through 'OUT 16'.</p>
In-Sight 1400 I/O Expansion Module	CIO-1400	 <p>The image shows the Cognex CIO-1400 I/O expansion module. It is a black printed circuit board with a different layout than the CIO-MICRO. It features a 'SPACE' label at the top left, a 'CONSOLE' label at the top center, and a 'RESISTOR' label at the top right. The 'CIO-1400' and 'COGNEX' branding is visible in the center. The bottom edge has pins labeled 'OUT 1' through 'OUT 16' and 'IN 1' through 'IN 16'.</p>

## Connectors and Indicators





Connector	Function
PWR Connector	Connects the Breakout cable, which provides connections to an external power supply, the acquisition trigger input, encoder inputs (9902L only), general-purpose inputs, high-speed outputs and RS-232 serial communications. For more information, refer to <a href="#">Breakout Cable on page 39</a> . Alternately, this connector is used to attach the I/O Module cable to a compatible In-Sight I/O module, which adds general-purpose discrete I/O. For more information, refer to <a href="#">I/O Module Cable on page 40</a> .
LIGHT Connector	Connects the vision system to an external lighting device. For more information, refer to <a href="#">External Light Connector on page 37</a> .  <b>Note:</b> In-Sight 9902L line scan vision system's external LIGHT connector is not supported.
ENET Connector	Connects the Ethernet cable, which provides 10/100/1000 Ethernet connectivity. For more information, refer to <a href="#">Ethernet Cable on page 38</a> .



Indicator	Function
	Indicates the image focus score (0 - 10) while in Live Video Mode within In-Sight Explorer.
	Manually triggers an image acquisition when the vision system is either: <ul style="list-style-type: none"> <li>Online within In-Sight Explorer and the acquisition Trigger parameter is set to Manual.</li> <li>Offline within In-Sight Explorer.</li> </ul>
	The green LED illuminates to indicate that the vision system is powered on.
	<ul style="list-style-type: none"> <li>Off: The SD card is not inserted.</li> <li>Green: The SD card is present, and it is safe to remove the SD card after removing power from the vision system.</li> <li>Yellow: The SD card is present, but it is not safe to remove it.</li> </ul>
	Green or red when active. User configurable.



Indicator		Function
	Network LED	The yellow LED flashes to indicate network activity.
	Error LED	Red when active. User configurable.
	TUNE Button	Used as an Event Trigger within In-Sight Explorer to force a cell containing an Event structure to run when the TUNE button is pressed.

# Installation

Read this section to learn how the vision system connects to its standard components and accessories. For a list of options and accessories, contact your Cognex sales representative.

**Note:** Cables are sold separately.

**CAUTION:** All cable connectors are keyed to fit the connectors on the vision system. Do not force the connections or damage may occur.

## Install the C-Mount Lens and Cover (COV-7000-CMNT-LG)

Complete the following steps to install a C-Mount lens and cover to the vision system. The C-Mount cover (COV-7000-CMNT-LG) is an optional accessory and required for IP67 protection.

**Note:**

- For the In-Sight 9902L vision system, the C-Mount lens has the following restrictions:
  - Maximum thread length is 5.25mm.
  - The C-Mount lens threads and body cannot protrude more than 6.5mm in length into the vision system when screwed in, unless the diameter of the back lens is smaller than 19.25mm. If the C-Mount lens threads and body protrude more than 6.5mm, you can add a spacer between the lens and vision system. However, the spacer decreases the working distance.
- If using the COV-7000-CMNT-LG cover with the In-Sight 9902L vision system, the maximum lens length is 77mm, the maximum lens body diameter is 55mm and the maximum diameter including locking screws is 55mm.

1. Remove the rubber faceplate covering the image sensor window, if present.
2. Remove the protective film covering the threaded lens opening, if present.
3. Place the adapter on the faceplate of the vision system. Insert the four adapter screws and tighten; the maximum torque is 0.90 Nm (8 in-lb).
4. Thread the lens into the vision system.
5. (Optional) For longer lenses, the C-Mount cover extender accessory (COV-7000-CMNT-LGX) can be used to add 30mm in length to the C-Mount cover. If using the cover extender, attach it to the vision system and rotate the cover extender clockwise approximately thirteen degrees to lock it.
6. Attach the cover to the vision system. Rotate the cover clockwise approximately thirteen degrees to lock it.



## Mount the Vision System

The vision system provides mounting holes for attachment to a mounting surface.

**CAUTION:** The vision system should be grounded, either by mounting the vision system to a fixture that is electrically grounded or by attaching a wire from the vision system's mounting fixture to frame ground or Earth ground. If a ground wire is used, it should be attached to one of the four mounting points on the back plate of the vision system and not to the mounting points on the front of the vision system.

1. Align the holes on the mounting surface with the mounting holes on the vision system.
2. Insert the M4 screws into the mounting holes and tighten using a 2.5mm hex wrench; the maximum torque is 0.90 Nm (8 in-lb).

**Note:** The maximum insertion depth of the M4 screws should be 6mm in the rear housing and 3.75mm in the front housing, plus the thickness of the mounting material used.



## Connect the External Light Cable (9912 Only)

The vision system's LIGHT connector is used to connect the External Light cable to an external lighting device, providing power and strobe control. The External Light cable can be connected to either a continuous or strobed lighting device. For a list of supported accessories, refer to [External Lights on page 12](#).

**Note:** In-Sight 9902L line scan vision system's external LIGHT connector is not supported.

1. Remove the protective cap from the LIGHT connector, if present.
2. Connect the External Light cable's M12 connector to the vision system's LIGHT connector. For more information, refer to [External Light Connector on page 37](#).

**Note:**

If interference from Electrical Fast Transient (EFT) is experienced under extreme factory conditions, a Fair-Rite ferrite (part number 0431176451) should be added as close to the vision system as practical, with the

**Note:** External Light cable looped through it. For example:



3. Connect the other end of the Light cable to an external lighting device (for example, a strobe light).



## Connect the Ethernet Cable

**CAUTION:** The Ethernet cable shield must be grounded at the far end. Whatever this cable is plugged into (typically a switch or router) should have a grounded Ethernet connector. A digital voltmeter should be used to validate the grounding. If the far end device is not grounded, a ground wire should be added in compliance with local electrical codes.

1. Connect the Ethernet cable's M12 connector to the vision system ENET connector.
2. Connect the Ethernet cable's RJ-45 connector to a switch/router or PC, as applicable.

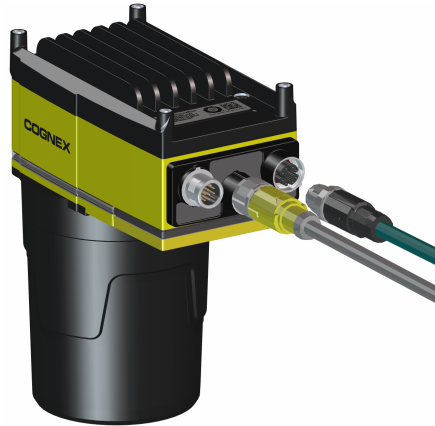

## Connect the Breakout Cable

**⚠ CAUTION:** To reduce emissions, connect the far end of the Breakout cable shield to frame ground.

**Note:**



- Perform wiring or adjustments to I/O devices when the vision system is not receiving power.
- You can cut exposed wires short or trim wire ends. You also can tie the wires back if you use a tie made of non-conductive material. Keep bare wires separated from the +24VDC wire.

1. Verify that the 24VDC power supply is unplugged and not receiving power.
2. Optionally, connect the I/O wires to an appropriate device (for example, a PLC or a serial device). For more information, refer to [Breakout Cable on page 39](#).
3. Attach the Breakout cable's +24VDC (Red wire) and GND (Black wire) to the corresponding terminals on the power supply.

**⚠ CAUTION:** Never connect voltages other than 24VDC. Always observe the polarity shown.

4. Connect the Breakout cable's M12 connector to the vision system PWR connector.

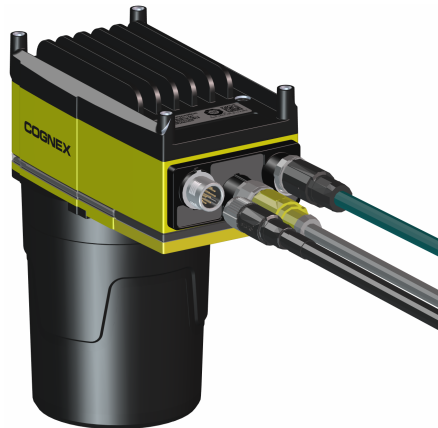

5. Restore power to the 24VDC power supply and turn it on if necessary.

## Replace the SD Card (Optional)

The vision system is equipped with a Micro SD card slot and an 8GB SD card is pre-installed for saving job and image files. Complete the following steps to replace the pre-installed SD card.

**Note:** The vision system supports SD cards with a maximum capacity of 32GB, formatted with a FAT32 file system.

**CAUTION:**

- Hot-plugging the SD card is not supported and may damage the SD card and/or lead to unexpected behavior.
- !**
- IP67 protection requires that all cables are properly attached (or the provided connector plug installed), the IP67-rated lens cover is properly installed, and the Micro SD card cover is fastened in place.
  - Observe ESD precautions when installing or removing an SD card or other accessories.

1. Remove power from the vision system.
2. Unscrew the screws in the Micro SD card cover and open the card slot.
3. Remove the existing SD card from the Micro SD card slot.
4. Insert the new SD card into the Micro SD card slot, ensuring the card is properly oriented.
5. Replace the SD card cover, reinsert the screws and torque screws to 0.18 Nm (25 in-oz).



6. Restore power to the vision system.

## Connect the CIO-MICRO I/O Module (Optional)

The vision system can access the CIO-MICRO I/O module's general-purpose input and output lines via an Ethernet connection to the I/O module. Optionally, the I/O Module cable can be connected to access the I/O module's TRIGGER+, TRIGGER-, HS OUT 0, HS OUT 1 and HS COMMON lines.

**Note:**

- When the In-Sight 9902L vision system is connected to the I/O Module cable, the vision system's ENCODER A INPUT, ENCODER B INPUT and IN 1 lines are not supported.
- When the In-Sight 9912 vision system is connected to the I/O Module cable:
  - Illumination accessories attached to the vision system LIGHT connector are not supported. If these illumination accessories are attached, the Breakout cable must be used to supply power to the vision system and a connection to the I/O module established via Ethernet only.
  - The vision system's IN 1, IN 2 / HS OUT 2, and IN 3 / HS OUT 3 lines are not supported.
- HS OUT 0 and HS OUT 1 are configurable as NPN (current sinking) or PNP (current sourcing) with 50mA maximum current and the general-purpose outputs are configurable as NPN (current sinking) or PNP (current sourcing) with 100mA maximum current.
- The CIO-MICRO I/O module does not support Gigabit pass-through operation. If you need Gigabit operation, connect a LAN cable from a Gigabit Ethernet switch to the I/O module's LAN port and connect the vision system Ethernet cable to the Gigabit Ethernet switch.
- Perform wiring or adjustments to I/O devices when the vision system is not receiving power.

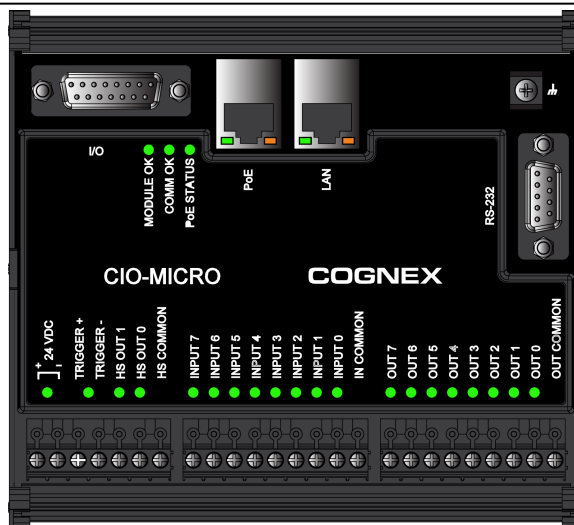

I/O Port	Connects the I/O module to the vision system using the I/O Module cable, and provides power, trigger and high-speed output signals to the vision system.
MODULE OK LED	Illuminates after the I/O module has powered on, has booted up, and is ready to communicate with the vision system.
COMM OK LED	Blinks continuously until the vision system has established a successful connection to the I/O module from In-Sight software. Once successfully connected and communicating properly, the green LED is constantly illuminated.
PoE STATUS LED	Not supported. When the vision system is connected to the I/O module's PoE port, the POE STATUS LED may blink. This is normal and does not affect operation of the vision system.

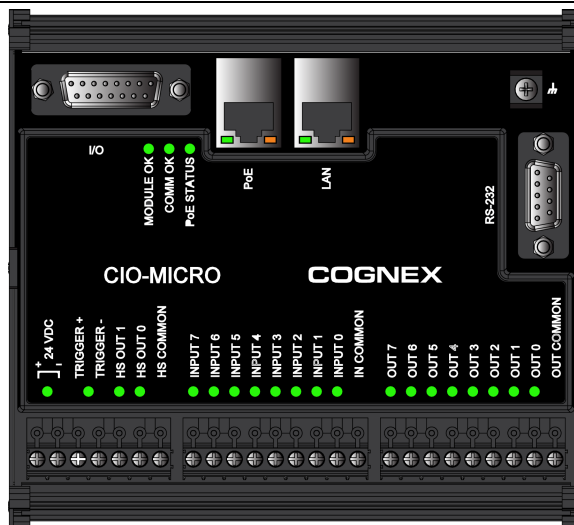

PoE Port	Connects the I/O module to the vision system, providing the vision system with Ethernet. The green LED blinks when a network connection to the vision system is detected. The orange LED blinks when network activity is detected.
LAN Port	Connects the I/O module to an Ethernet network. The green LED blinks when a network connection to the local area network is detected. The orange LED blinks when network activity is detected.
Frame Ground Terminal	Connects the I/O module to a frame ground.
RS-232 Port	Connects the I/O module to an external serial device using an RS-232 (DB9) serial cable. Provides RS-232 communications to the vision system.
High-Speed Output Status LEDs (HS OUT 0 and HS OUT 1)	<p>Illuminates to indicate the high-speed output signal for the In-Sight vision system has switched ON. The LEDs illuminate even if the I/O module's high-speed terminals are not connected to anything. In addition, the I/O module displays the last known state of the high-speed output line. Therefore, the LEDs may be illuminated even if the vision system's I/O module cable is disconnected from the I/O module.</p> <p><b>Note:</b> The I/O module's high-speed output terminals (labeled HS OUT 0 and HS OUT 1) correspond to the vision system's built-in high-speed outputs when connected to the I/O module cable. These signals are considered high-speed because they pass directly through the I/O module without processing, which provides minimal delay.</p>
I/O and Trigger Status LEDs	Illuminates to indicate that an input/output signal has switched ON.
Terminal Blocks	Connects the I/O module to 24VDC power, trigger, external I/O, high-speed outputs and common connections.

1. Connect the I/O module's power wires.

**CAUTION:** Never connect the I/O module to a power source other than 24VDC. Any other voltage creates a risk of fire or shock and can damage the hardware. Do not connect the 24VDC power source to any terminals other than the 24VDC + and – power terminals.

- a. Verify that the 24VDC power supply is unplugged and not receiving power.
- b. Use a screwdriver to loosen the I/O module's power terminals (labeled 24VDC + and –).
- c. Insert the 24VDC + and – wires (16 - 22 AWG, solid or stranded wire) from the power supply into the 24VDC + and – terminals on the I/O module.

- d. Tighten the screw terminals with the screwdriver to secure the wire leads in the terminal block; the maximum torque is 0.1921 Nm (1.7 in-lb).
2. Connect a frame ground wire to the I/O module's Frame Ground terminal. Connect the other end of the frame ground wire to frame ground.

---

**CAUTION:** The shield ground connections of the RS-232 port, LAN port, PoE port, I/O port and Frame Ground terminal are internally connected. The system grounding is at a zero ground potential. This zero-ground potential extends through the cable and to peripheral equipment, such as a vision system or PLC.  To ensure safe operating conditions, check ground connections to ensure that they meet a zero ground potential.

---

3. Connect the I/O module's I/O wires.
  - a. Determine how I/O devices will be connected to the I/O module's input and output terminals.
  - b. To loosen the appropriate screw terminals, use a screwdriver.
  - c. Connect the input and output wires to the input and output terminals.
  - d. Connect the other end of the input and output wires to the corresponding I/O device.
  - e. Tighten the screw terminals with the screwdriver to secure the wire leads in the terminal block; the maximum torque is 0.1921 Nm (1.7 in-lb).
4. To connect the vision system to a serial device, plug a RS-232 serial cable (DB9 male connector) into the I/O module's RS-232 port and connect the other end of the cable to the serial device. Tighten the connector screws to secure it to the I/O module.
5. Connect to an Ethernet network.
  - a. Connect a LAN cable (RJ-45 connector) to the I/O module's LAN port.
  - b. Connect the other end of the LAN cable to a switch/router or PC, as applicable.
6. Connect the vision system's Ethernet cable.
  - a. Connect the Ethernet cable's M12 connector to the vision system ENET connector.
  - b. Connect the Ethernet cable's RJ-45 connector to the I/O module's PoE port or to a switch/router, as applicable.
7. (Optional) Connect the I/O Module cable (CCB-PWRIO-MOD-xx) to the vision system to gain access to the I/O module's TRIGGER+, TRIGGER-, HS OUT 0, HS OUT 1 and HS COMMON terminals.
  - a. Connect the I/O Module cable's M12 connector to the vision system's PWR connector.
  - b. Connect the I/O Module cable's DB15 connector to the I/O module's I/O connector.
  - c. Restore power to the 24VDC power supply and turn it on if necessary.

## Connect the CIO-1400 I/O Expansion Module (Optional)

**Note:**



- When connected to the CIO-1400 I/O expansion module:
  - HS OUT 0 and HS OUT 1 are configurable as NPN (current sinking) with 50mA maximum current and the general-purpose outputs are configurable as NPN (current sinking) or PNP (current sourcing) with 100mA maximum current.
  - The 9902Lvision system's ENCODER A INPUT, ENCODER B INPUT and IN 1 lines are not supported.
  - The 9912 vision system's IN 1, IN 2 / HS OUT 2, and IN 3 / HS OUT 3 lines are not supported.
- Perform wiring or adjustments to I/O devices when the vision system is not receiving power.

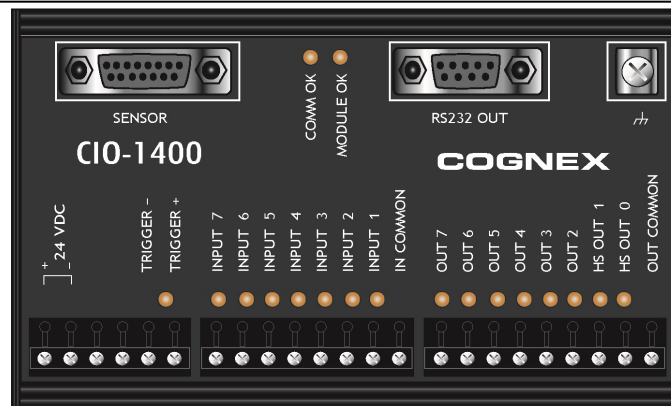

Connector/Indicator	Description
COMM OK LED (yellow)	Illuminates to indicate that the vision system and I/O module are communicating properly.
MODULE OK LED (yellow)	Illuminates after the I/O module has initialized and is ready to communicate with the vision system.
I/O and Trigger Status LEDs (yellow)	Illuminates to indicate when an input/output has switched ON.
SENSOR Port	Connects the I/O module to the vision system using the I/O Module cable, which provides power, trigger, I/O and RS-232 signals to the vision system.
RS232 OUT Port	Connects the I/O module to an RS-232 serial cable, which provides RS-232 communications between the I/O module and an external serial device.
Frame Ground Terminal	Connects the I/O module to a common frame ground.

1. Connect the I/O module's power wires.

**CAUTION:** Never connect the I/O module to a power source other than 24VDC. Any other voltage creates a risk of fire or shock and can damage the hardware. Do not connect the 24VDC power source to any terminals other than the 24VDC + and – power terminals.

- a. Verify that the 24VDC power supply is unplugged and not receiving power.
- b. Use a screwdriver to loosen the I/O module's power terminals (labeled 24VDC + and –).
- c. Insert the 24VDC + and – wires (16 - 26 AWG, solid or stranded wire) from the power supply into the 24VDC + and – terminals on the I/O module.

- d. Tighten the screw terminals with the screwdriver to secure the wire leads in the terminal block; the maximum torque is 0.4 Nm (3.5 in-lb).
2. Connect a frame ground wire to the I/O module's Frame Ground terminal. Connect the other end of the frame ground wire to frame ground.

---

**CAUTION:** The shield ground connections of the RS232 OUT port, SENSOR port and Frame Ground terminal are internally connected. The system grounding is designed to be at a zero ground potential; this zero ground potential extends through the cable and to peripheral equipment (e.g. a vision system, PLC, etc.). To ensure safe operating conditions, it is strongly recommended that all ground connections are checked to ensure that a zero ground potential is met.

---

- a. Determine how I/O devices will be connected to the I/O module's input and output terminals.
    - b. To loosen the appropriate screw terminals, use a screwdriver.
    - c. Connect the input and output wires to the input and output terminals.
    - d. Connect the other end of the input and output wires to the corresponding I/O device.
    - e. Tighten the screw terminals with the screwdriver to secure the wire leads in the terminal block; the maximum torque is 0.4 Nm (3.5 in-lb).
3. Connect the I/O module's I/O wires.
4. To connect the vision system to a serial device, plug an RS-232 serial cable (DB9 male connector) into the I/O module's RS232 OUT port and connect the other end of the cable to the serial device. Tighten the connector screws to secure it to the I/O module.
5. Connect the I/O Module cable (CCB-PWRIO-MOD-xx) to the vision system.
  - a. Connect the I/O Module cable's M12 connector to the vision system's PWR connector.
  - b. Connect the I/O Module cable's DB15 connector to the I/O module's SENSOR port.
  - c. Restore power to the 24VDC power supply and turn it on if necessary.

# Specifications

The following sections list general specifications for the vision system.

## 9902L Vision System Specifications

Specifications	9902L
Minimum Firmware Requirement	In-Sight version 5.6.1 PR1
Job/Program Memory	7.2GB non-volatile flash memory; unlimited storage via remote network device.
Image Processing Memory	In-Sight firmware version 5.6.1 PR1: 512MB SDRAM
	In-Sight firmware version 5.7.0 and later: 832MB SDRAM
SD Card Slot	1 Micro SD card slot with an 8GB SD card pre-installed for saving job and image files. The vision system supports SD cards with a maximum capacity of 32GB, formatted with a FAT32 file system.
Sensor Type	1-inch CMOS, line sensor
Sensor Properties	7 $\mu$ m x 7 $\mu$ m active area, 7 $\mu$ m x 7 $\mu$ m sq. pixels
Maximum Resolution (pixels) <sup>1</sup>	2048 x 16384
	1K Resolution (Low Light Mode): 1024 x 16384
Acquisition	Line Scan integration.
Bit Depth	256 grey levels (8 bits/pixel)
Lines Per Second (LPS)	66 KHz LPS (15 $\mu$ s scan rate)
Lens Type	C-Mount
Trigger	1 opto-isolated, acquisition trigger input. Remote software commands via Ethernet.
Discrete Inputs	<ul style="list-style-type: none"> <li>• 1 general-purpose input when connected to the Breakout cable.</li> <li>• 8 general-purpose inputs available when connected to the CIO-MICRO I/O Module via the I/O Module cable.</li> <li>• 7 general-purpose inputs available when connected to the CIO-1400 I/O Expansion Module via the I/O Module cable.</li> </ul>
Discrete Outputs	<ul style="list-style-type: none"> <li>• 2 high-speed outputs when connected to the Breakout cable.</li> <li>• 2 high-speed outputs, plus 8 general-purpose outputs available when connected to the CIO-MICRO I/O Module via the I/O Module cable.</li> <li>• 2 high-speed outputs, plus 6 general-purpose outputs available when connected to the CIO-1400 I/O Expansion Module via the I/O Module cable.</li> </ul>
Encoder Inputs	2 built-in, encoder inputs for use with a 5 to 24VDC signal.
Status LEDs	SD Card Status, Pass/Fail LED and Indicator Ring, Network LED and Error LED.
Network Communication	1 Ethernet port, 10/100/1000 BaseT with auto MDIX. IEEE 802.3 TCP/IP Protocol. Supports DHCP, static and link-local IP address configuration.
1588 Support	Timestamp Resolution: 8ns Synchronization Accuracy Through Transparent Clock: 5 $\mu$ s

<sup>1</sup> The default resolution is 2048 x 4096. The width and maximum image height can be adjusted in the Line Scan Settings dialog within In-Sight Explorer. If the 1K Resolution (Low Light Mode) checkbox is selected, the width is decreased to 1024, providing increased light sensitivity. Within the AcquireImage function, the Number of Lines parameter value can range from 1 to the Max Image Height.

Specifications	9902L
Serial Communication	RS-232C when connected to the Breakout cable <sup>1</sup> or a compatible I/O module.
Power Consumption	24VDC ±10%, 1.5A maximum
Material	Die-cast and extruded aluminum housing.
Finish	Painted.
Mounting	Four M4 threaded mounting holes on front and back of the vision system.
Dimensions	<ul style="list-style-type: none"> <li>• 53.4mm (2.10in) x 60.5mm (2.38in) x 121.0mm (4.77in)</li> <li>• 135.7 (5.34in) x 68.0mm (2.68in) x 121.0mm (4.77in) with C-Mount cover accessory (COV-7000-CMNT-LG).</li> <li>• 165.7 (6.52in) x 68.0mm (2.68in) x 121.0mm (4.77in) with C-Mount cover accessory (COV-7000-CMNT-LG) and C-Mount cover extender accessory (COV-7000-CMNT-LGX).</li> </ul>
Weight	<ul style="list-style-type: none"> <li>• Vision System with no accessories attached: 400 g (14.1 oz.)</li> <li>• C-Mount cover accessory (COV-7000-CMNT-LG): 75.9 g (2.68 oz.)</li> <li>• C-Mount cover extender accessory (COV-7000-CMNT-LGX): 25.0 g (0.88 oz.)</li> </ul>
Case Temperature <sup>2</sup>	0°C to 50°C (32°F to 122°F).
Storage Temperature	-20°C to 80°C (-4°F to 176°F)
Humidity	< 80% non-condensing
Protection	IP67 with all cables properly attached (or the provided connector plug installed), the IP67-rated cover properly installed, and the Micro SD card cover fastened in place.
Shock (Shipping and Storage)	IEC 60068-2-27: 18 shocks (3 shocks in each polarity in each (X, Y, Z) axis) 80 Gs (800m/s <sup>2</sup> at 11 ms, half-sinusoidal) with cables or cable plugs and a 150 gram or lighter lens attached.
Vibration (Shipping and Storage) <sup>3</sup>	IEC 60068-2-6: vibration test in each of the three main axis for 2 hours @ 10 Gs (10 to 500 Hz at 100m/s <sup>2</sup> / 15mm) with cables or cable plugs and a 150 gram or lighter lens attached.
Regulations/Conformity	CE, FCC, KCC, TÜV SÜD NRTL, EU RoHS, China RoHS

<sup>1</sup> If hardware handshaking is required, an I/O module must be used.

<sup>2</sup> To verify case temperature, use the EV GetSystemConfig("Internal.Temperature") Extended Native Mode command. When issued, it returns the vision system internal temperature in degrees Celsius, which is approximately 3 to 5 degrees above the vision system case temperature. For more information, see the *In-Sight® Explorer Help* file. A thermal scanner can also be used to determine the vision system case temperature. Additional cooling measures are required if the case temperature cannot be kept below 50°C. Examples of such measures include: extra heat sinking and/or air movement.

<sup>3</sup> Before you ship this product or any machinery that contains it, remove lenses that weigh more than 150 grams.

## 9912 Vision System Specifications

Specifications	9912	9912C
Minimum Firmware Requirement	In-Sight version 5.7.0	
Job/Program Memory	7.2GB non-volatile flash memory; unlimited storage via remote network device.	
Image Processing Memory	832MB SDRAM	
SD Card	1 Micro SD card slot with an 8GB SD card pre-installed for saving job and image files. The vision system supports SD cards with a maximum capacity of 32GB, formatted with a FAT32 file system.	
Sensor Type	1.1-inch CMOS, global shutter	
Sensor Properties	17.6mm diagonal, 3.45 x 3.45µm sq. pixels	
Maximum Image Resolution (pixels) <sup>1</sup>	4096 x 3000	
Electronic Shutter Speed	21µs to 1000ms	
Acquisition	Rapid reset, progressive scan, full-frame integration. High Dynamic Range (HDR) available.	
Bit Depth	256 grey levels (8 bits/pixel)	24-bit color
Frames Per Second (FPS) <sup>2</sup>	14 FPS	8 FPS
Lens Type	C-Mount	
Trigger	1 opto-isolated, acquisition trigger input.	
Discrete Inputs	<ul style="list-style-type: none"> <li>• 3 general-purpose inputs when connected to the Breakout cable.<sup>3</sup></li> <li>• 8 general-purpose inputs available when connected to the CIO-MICRO I/O Module via the I/O Module cable.</li> <li>• 7 general-purpose inputs available when connected to the CIO-1400 I/O Expansion Module via the I/O Module cable.</li> </ul>	
Discrete Outputs	<ul style="list-style-type: none"> <li>• 4 high-speed outputs when connected to the Breakout cable.<sup>4</sup></li> <li>• 2 high-speed outputs, plus 8 general-purpose outputs available when connected to the CIO-MICRO I/O Module via the I/O Module cable.</li> <li>• 2 high-speed outputs, plus 6 general-purpose outputs available when connected to the CIO-1400 I/O Expansion Module via the I/O Module cable.</li> </ul>	
Status LEDs	SD Card Status, Pass/Fail LED and Indicator Ring, Network LED and Error LED.	
Network Communication	1 Ethernet port, 10/100/1000 BaseT with auto MDIX. IEEE 802.3 TCP/IP Protocol. Supports DHCP, static and link-local IP address configuration.	
1588 Support	Timestamp Resolution: 8ns Synchronization Accuracy Through Transparent Clock: 5µs	

<sup>1</sup> You can configure the number of image sensor rows and set them in the In-Sight Explorer software. If you decrease the number of rows, it increases the frames per second acquired by the vision system. Refer to the AcquireImage topic in the *In-Sight® Explorer Help* file for more information.

<sup>2</sup> Maximum frames per second are job-dependent, based on the minimum exposure for a full image frame capture using the dedicated acquisition trigger, and assumes there is no user interface connection to the vision system.

<sup>3</sup> When connected to the Breakout cable, the vision system allows for bi-directional, high-speed outputs and general-purpose inputs for HS OUT 2 / IN 2 and HS OUT 3 / IN 3. These lines are configured as outputs by default.

<sup>4</sup> When connected to the Breakout cable, the vision system allows for bi-directional, high-speed outputs and general-purpose inputs for HS OUT 2 / IN 2 and HS OUT 3 / IN 3. These lines are configured as outputs by default.

Specifications	9912	9912C
Serial Communication	RS-232C when connected to the Breakout cable <sup>1</sup> or a compatible I/O module.	
Power Consumption	24VDC ±10%, 1.5A maximum	
Power Output	24VDC @ 750mA maximum to external light.	
Material	Die-cast and extruded aluminum housing.	
Finish	Painted.	
Mounting	Four M4 threaded mounting holes on front and back of the vision system.	
Dimensions	<ul style="list-style-type: none"> <li>• 53.4mm (2.10in) x 60.5mm (2.38in) x 121.0mm (4.77in)</li> <li>• 135.7 (5.34in) x 68.0mm (2.68in) x 121.0mm (4.77in) with C-Mount cover accessory (COV-7000-CMNT-LG).</li> <li>• 165.7 (6.52in) x 68.0mm (2.68in) x 121.0mm (4.77in) with C-Mount cover accessory (COV-7000-CMNT-LG) and C-Mount cover extender accessory (COV-7000-CMNT-LGX).</li> </ul>	
Weight	<ul style="list-style-type: none"> <li>• Vision System with no accessories attached: 400 g (14.1 oz.)</li> <li>• C-Mount cover accessory (COV-7000-CMNT-LG): 75.9 g (2.68 oz.)</li> <li>• C-Mount cover extender accessory (COV-7000-CMNT-LGX): 25.0 g (0.88 oz.)</li> </ul>	
Case Temperature <sup>2</sup>	0°C to 50°C (32°F to 122°F).	
Storage Temperature	-20°C to 80°C (-4°F to 176°F)	
Humidity	< 80% non-condensing	
Protection	IP67 with all cables properly attached (or the provided connector plug installed), the IP67-rated cover properly installed, and the Micro SD card cover fastened in place.	
Shock (Shipping and Storage)	IEC60068-2-27: 18 shocks (3 shocks in each polarity in each (X, Y, Z) axis) 80 Gs (800m/s <sup>2</sup> at 11ms, half-sinusoidal) with cables or cable plugs and a 350 gram or lighter lens attached.	
Vibration (Shipping and Storage) <sup>3</sup>	IEC60068-2-6: vibration test in each of the three main axis for 2 hours @ 10 Gs (10 to 500 Hz at 100m/s <sup>2</sup> / 15mm) with cables or cable plugs and a 350 gram or lighter lens attached.	
Regulations/Conformity	CE, FCC, KCC, TÜV SÜD NRTL, EU RoHS, China RoHS	

<sup>1</sup> If hardware handshaking is required, an I/O module must be used.

<sup>2</sup> To verify case temperature, use the EV GetSystemConfig("Internal.Temperature") Extended Native Mode command. When issued, it returns the vision system internal temperature in degrees Celsius, which is approximately 3 to 5 degrees above the vision system case temperature. For more information, see the *In-Sight® Explorer Help* file. A thermal scanner can also be used to determine the vision system case temperature. Additional cooling measures are required if the case temperature cannot be kept below 50°C. Examples of such measures include: extra heat sinking and/or air movement.

<sup>3</sup> Before you ship this product or any machinery that contains it, remove lenses that weigh more than 350 grams.

## Acquisition Trigger Input

The vision system features one acquisition trigger input, which is optically isolated. You can configure the acquisition trigger input to trigger from an NPN (current sinking) or PNP (current sourcing) device.

Specification	Description
Voltage	ON: 15 to 28V DC (24VDC nominal) OFF: 0 to 5VDC (11.5VDC nominal threshold)
Current (Typical)	ON: 2.6mA to 4.9mA from 15 to 28V input OFF: < 830 $\mu$ A for < 5VDC input Resistance: ~6 kOhms
Delay	9902L: 1 line + 5 $\mu$ s is the maximum latency between the leading edge of the trigger and the start of acquisition. The line period varies depending on acquisition settings. Input pulse should be a minimum of 1ms wide. 9912: 190 $\mu$ s maximum latency between leading edge of trigger and start of acquisition. Input pulse should be a minimum of 1ms wide.

- To trigger from an NPN type photoelectric sensor or PLC output, connect COMMON IN to +24VDC and connect TRIGGER to the output of the photoelectric sensor. When the output turns ON, it pulls TRIGGER down to 0VDC, turning the opto-coupler ON. For more information, refer to [Breakout Cable on page 39](#).
- To trigger from a PNP photoelectric sensor or PLC output, connect TRIGGER to the output of the photoelectric sensor and connect COMMON IN to 0VDC. When the output turns ON, it pulls TRIGGER up to +24VDC, turning the opto-coupler ON. For more information, refer to [Breakout Cable on page 39](#).

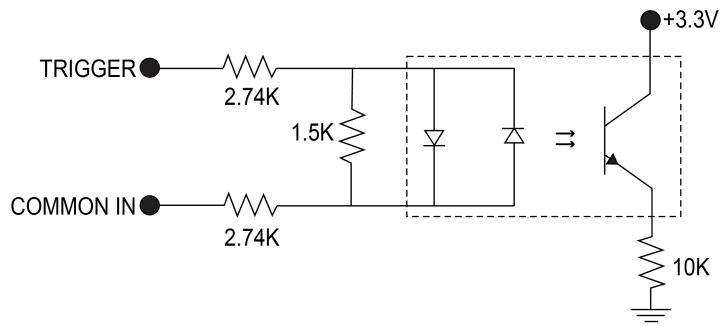

26.4V Max. across input pins - Transition approximately 12V (Min.)

## 9902L Encoder Inputs

The Breakout cable can be used for communication between the vision system and a single or quadrature encoder.

Specification	Description
Voltage	ON: 5 to 24VDC OFF: <2VDC
Current	ON: <1000 $\mu$ A OFF: 0 $\mu$ A Resistance: ~350 kOhms
Maximum Encoder Frequency	96KHz (assuming a 50/50 duty cycle)

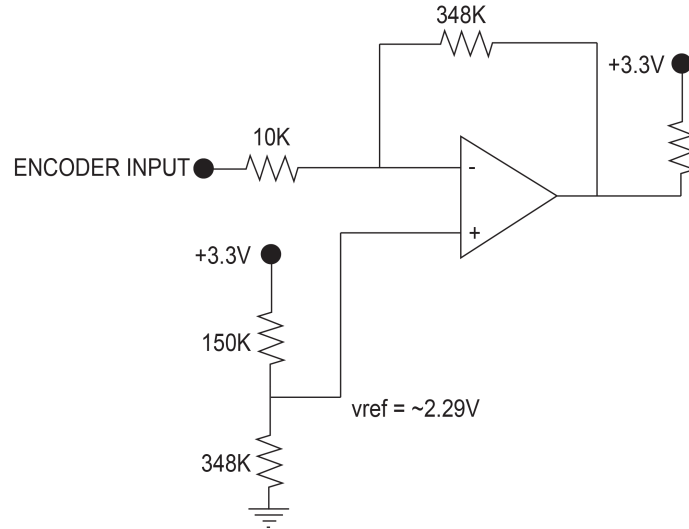

## 9902L Encoder Input Wiring

For single encoders, the ENCODER A pin must be used. For quadrature encoders, the ENCODER A or ENCODER B pin can be used. For more information, refer to [Breakout Cable on page 39](#).

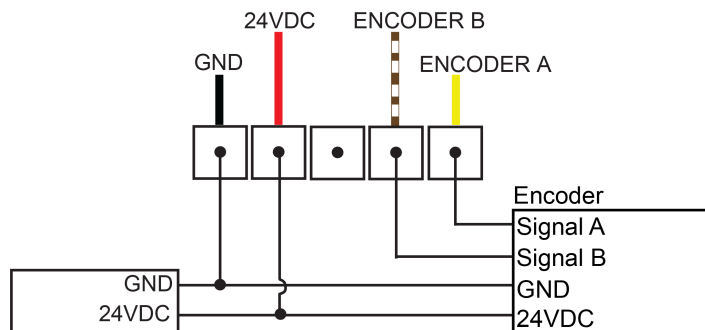

## General-Purpose Inputs

- The 9902L vision system features one built-in general-purpose input, which is optically isolated. The input can be configured as either NPN (current sinking) or PNP (current sourcing) lines.
- The 9912 vision system features three<sup>1</sup> built-in general-purpose inputs, which are optically isolated. The inputs can be configured as either NPN (current sinking) or PNP (current sourcing) lines.

Specification	Description
Voltage	ON: 15 to 28V DC (24VDC nominal) OFF: 0 to 5VDC (11.5VDC nominal threshold)
Current (Typical)	ON: 2.6mA to 4.9mA from 15 to 28V input OFF: < 830 $\mu$ A for < 5VDC input Resistance: ~6 kOhms
Delay	1.11ms maximum latency between leading edge of trigger and start of acquisition. Input pulse should be a minimum of 1ms wide.

- For NPN lines, connect COMMON IN to +24VDC and connect IN 1 to the output of the photoelectric sensor or PLC. When the output turns ON, it pulls IN 1 down to 0VDC, turning the opto-coupler ON.
- For PNP lines, connect IN 1 to the output of the detector and connect COMMON IN to 0VDC. When the output turns ON, it pulls IN 1 up to +24VDC, turning the opto-coupler ON.

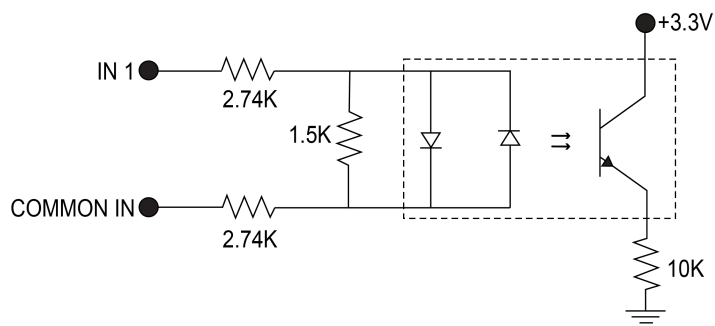

26.4V Max. across input pins - Transition approximately 12V (Min.)

<sup>1</sup>When connected to the Breakout cable, the In-Sight 9912 vision system allows for bi-directional, high-speed outputs and general-purpose inputs for HS OUT 2 / IN 2 and HS OUT 3 / IN 3. These lines are configured as outputs by default.

## High-Speed Outputs

- The 9902L vision system features two built-in, high-speed outputs, which are optically isolated. The high-speed outputs can be used as either NPN (current sinking) or PNP (current sourcing) lines.
- The 9912 vision system features four<sup>1</sup> built-in, high-speed outputs, which are optically isolated. The high-speed outputs can be used as either NPN (current sinking) or PNP (current sourcing) lines.

Specification	Description
Voltage	26.4VDC maximum through external load
Current	50mA maximum sink or source current
	OFF state leakage current 100µA
	External load resistance 470 Ohms to 10K Ohms
	Each line rated at a maximum 50mA, protected against over-current, short circuits and transients from switching inductive loads. High current inductive loads require an external protection diode.
Delay <sup>2</sup>	25µs (maximum due to opto-isolators turning ON).

For NPN lines, the external load should be connected between the output and the positive supply voltage (<26.4VDC). The output pulls down to less than 3VDC when ON, which causes current to flow through the load. When the output is OFF, no current flows through the load.

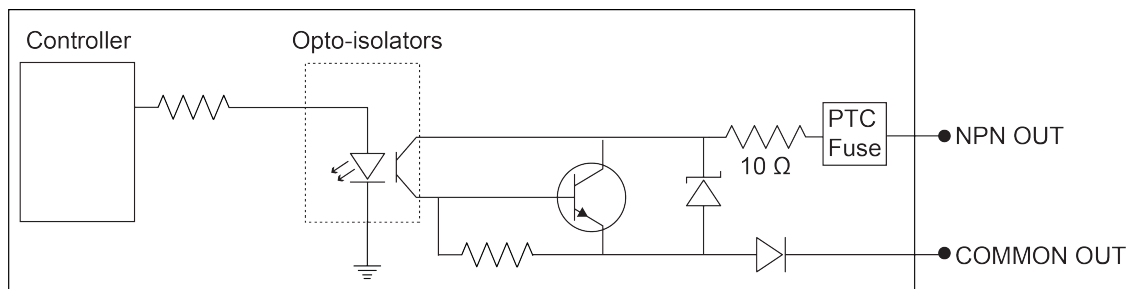

For PNP lines, the external load should be connected between the output and the negative supply voltage (0VDC). When connected to a 24VDC power supply, the output pulls up greater than 21VDC when ON, and current flows through the load. When the output is OFF, no current flows through the load.

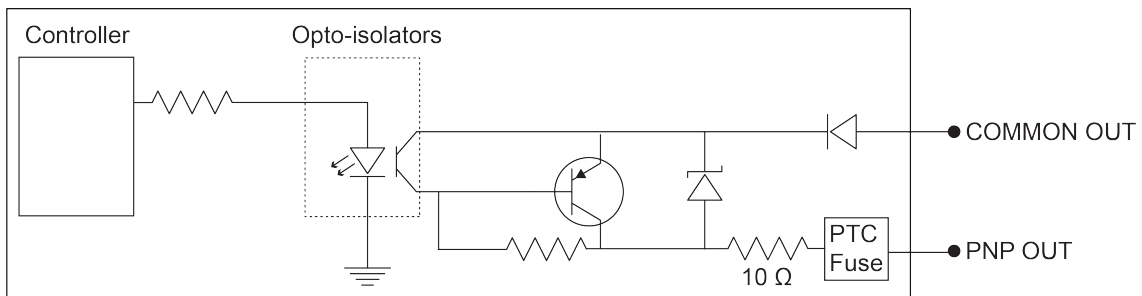

<sup>1</sup> When connected to the Breakout cable, the In-Sight 9912 vision system allows for bi-directional, high-speed outputs and general-purpose inputs for HS OUT 2 / IN 2 and HS OUT 3 / IN 3. These lines are configured as outputs by default.

<sup>2</sup> Delay when opto-isolators turn OFF depends on the load to which the output is connected. With a 470 Ohm load, the maximum delay will be 200µs.

## High-Speed Output Wiring

To connect to an NPN-compatible PLC input, connect one of the vision system's high-speed outputs directly to the PLC input. When enabled, the output pulls the PLC input down to less than 3VDC.

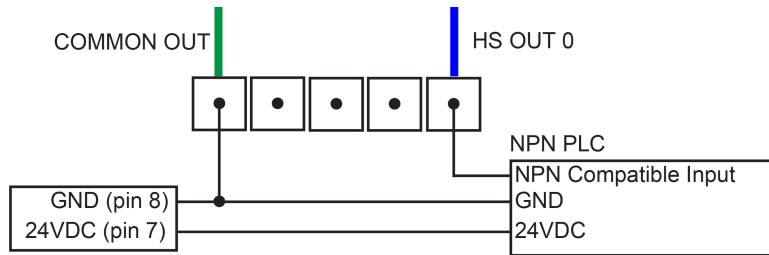

To connect to a PNP-compatible PLC input, connect one of the vision system's high-speed outputs directly to the PLC input. When enabled, the output pulls the PLC input up to greater than 21VDC.

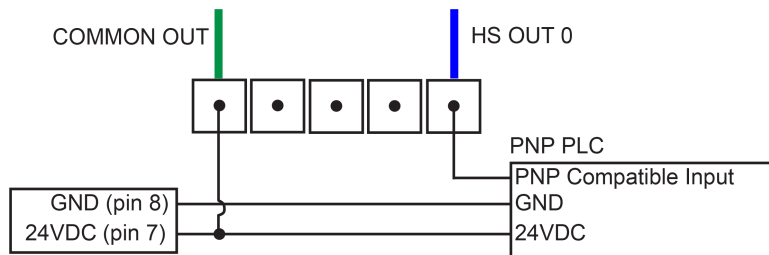

To connect the high-speed outputs to a relay, LED or similar load, connect the negative side of the load to the output and the positive side to +24VDC. When the output switches on, the negative side of the load is pulled down to less than 3VDC, and 24VDC appears across the load. Use a protection diode for a large inductive load, with the anode connected to the output and the cathode connected to +24VDC.

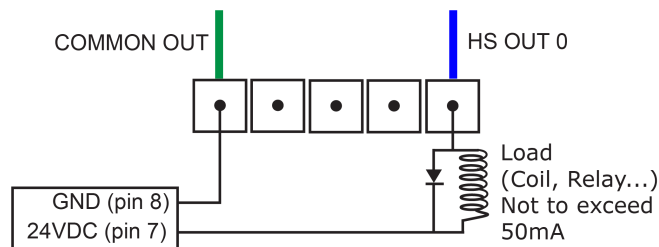

## External Light Connector

The vision system's LIGHT connector is used to connect the External Light cable to an external lighting device, providing power and strobe control. The External Light cable can be connected to either a continuous or strobed lighting device. Before using an external lighting device, you must configure the light settings within In-Sight Explorer. For more information, refer to the Light Settings topic in the *In-Sight® Explorer Help* file.

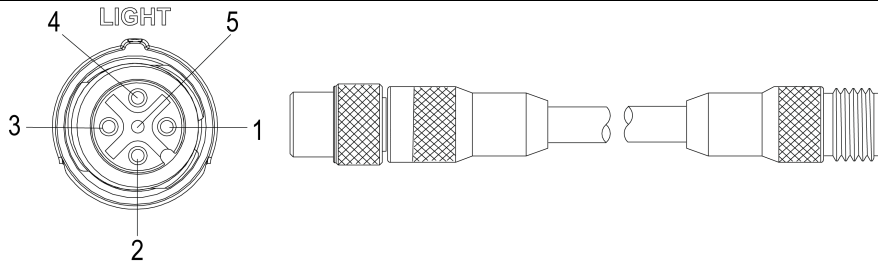

Pin#	Signal Name	Wire Color
1	+24VDC	Brown
2	Intensity Control	White
3	GND	Blue
4	Strobe	Black
5	Chassis	Not Connected

### Note:

- In-Sight 9902L line scan vision system's external LIGHT connector is not supported.
- Cables are sold separately.
- The External Light cables with the following product IDs do not support intensity control: CCB-M12LTF-xx, IVSL-M12-NSB-300, IVSL-M12-NSB-1000 and IVSL-M12-NSB-2000. If intensity control is required, use External Light cables with the following product IDs: IVSL-5PM12-J300, IVSL-5PM12-J500, IVSL-5PM12-J1000 and IVSL-5PM12-J2000.
- Current load: 750 mA maximum. Only the +24VDC pin is capable of sourcing 750mA.
- Intensity Control is an analog signal that ranges from 0 to +10VDC, and is configurable within In-Sight Explorer. It is a control signal only, and must not be used to power an external device. Power should be sourced from +24VDC and GND.
- The Strobe output is active low 0VDC and active high +12VDC, with the Polarity configurable within In-Sight Explorer. It is a control signal only and may not to be used for power. Power should be sourced from +24VDC and GND.

## Ethernet Cable

The Ethernet cable provides Ethernet connectivity to the vision system.

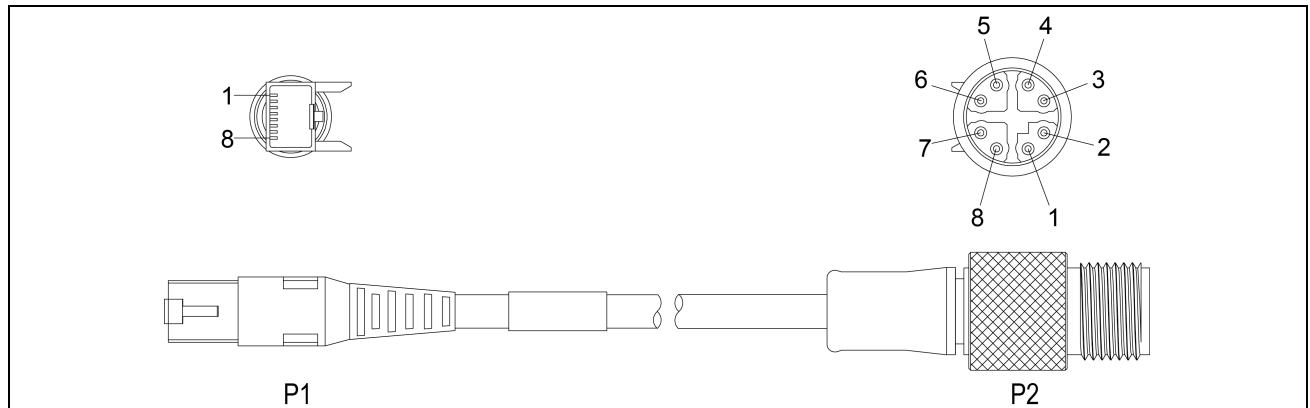

P1 Pin Number	Wire Color	Signal Name	P2 Pin Number
1	White/Orange	TxRx A +	1
2	Orange	TxRx A -	2
3	White/Green	TxRx B +	3
4	Blue	TxRx C +	8
5	White/Blue	TxRx C -	7
6	Green	TxRx B -	4
7	White/Brown	TxRx D +	5
8	Brown	TxRx D -	6

**CAUTION:** The Ethernet cable shield must be grounded at the far end. Whatever this cable is plugged into (typically a switch or router) should have a grounded Ethernet connector. A digital voltmeter should be used to validate the grounding. If the far end device is not grounded, a ground wire should be added in compliance with local electrical codes.

**Note:**



- Cables are sold separately.
- The wiring for this cable follows standard industrial Ethernet M12 specifications. It differs from the 568B standard.

## Breakout Cable

The Breakout cable provides connections to an external power supply, the acquisition trigger input, encoder inputs (9902L only), general-purpose inputs, high-speed outputs, and RS-232 serial communications. The Breakout cable is not terminated.

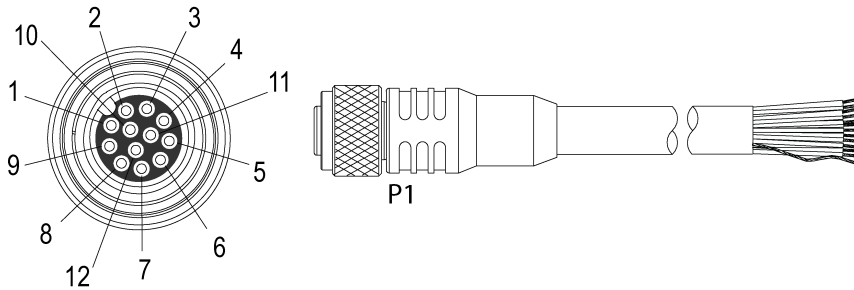

Pin#	9902L Signal Names	9912 Signal Names	Wire Color
1	ENCODER A INPUT	IN 2 / HS OUT 2	Yellow
2	RS-232 TRANSMIT	RS-232 TRANSMIT	White/Yellow
3	RS-232 RECEIVE	RS-232 RECEIVE	Brown
4	ENCODER B INPUT	IN 3 / HS OUT 3	White/Brown
5	IN 1	IN 1	Violet
6	COMMON IN	COMMON IN	White/Violet
7	+24VDC	+24VDC	Red
8	GND	GND	Black
9	COMMON OUT	COMMON OUT	Green
10	TRIGGER	TRIGGER	Orange
11	HS OUT 0	HS OUT 0	Blue
12	HS OUT 1	HS OUT 1	Grey

### Note:

- Cables are sold separately.
- You can cut exposed wires short or trim wire ends. You also can tie the wires back if you use a tie made of non-conductive material. Keep bare wires separated from the +24VDC wire.
- If hardware handshaking is required for serial communication, an I/O module must be used.
- Perform wiring or adjustments to I/O devices when the vision system is not receiving power.

## I/O Module Cable

The I/O Module cable connects the vision system directly to a compatible I/O module via the DB15 connector. When the I/O module is used, all power and communication lines used by the vision system are connected using the I/O Module cable.

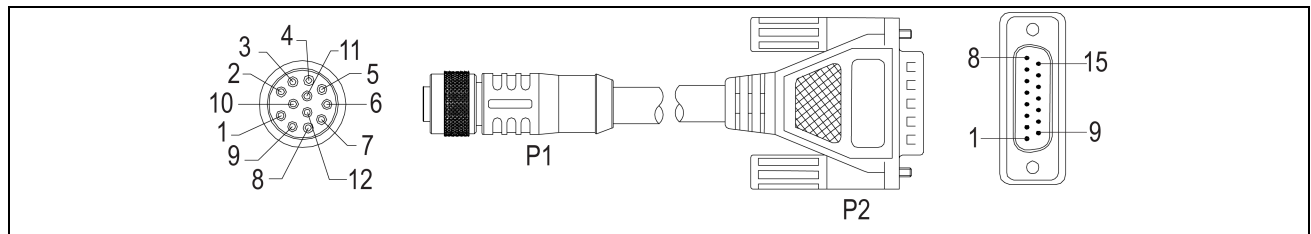

P1 Pin#	Signal Name	Wire Color	Signal Name	P2 Pin#
1	IN 2 / HS OUT 2	Yellow	Not Used	Not Used
2	RS-232 TRANSMIT	White/Yellow	RS-232 RECEIVE	7
3	RS-232 RECEIVE	Brown	RS-232 TRANSMIT	6
4	IN 3 / HS OUT 3	White/Brown	Not Used	Not Used
5	IN 1	Violet	Not Used	Not Used
6	COMMON IN	White/Violet	TRIGGER-	3
7	+24VDC	Red	+24VDC	1
8	GND	Black	-24VDC	8
9	COMMON OUT	Green	-24VDC	8
10	TRIGGER	Orange	TRIGGER+	2
11	HS OUT 0	Blue	HS OUT 0	4
12	HS OUT 1	Grey	HS OUT 1	5

**Note:** Cables are sold separately.

# Dimensions

The following sections list dimensions of the vision system and optional accessories.

## 9902L Vision System Dimensions

**Note:**



- Dimensions are in millimeters [inches] and are for reference purposes only.
- All specifications are for reference purposes only and can change without notice.

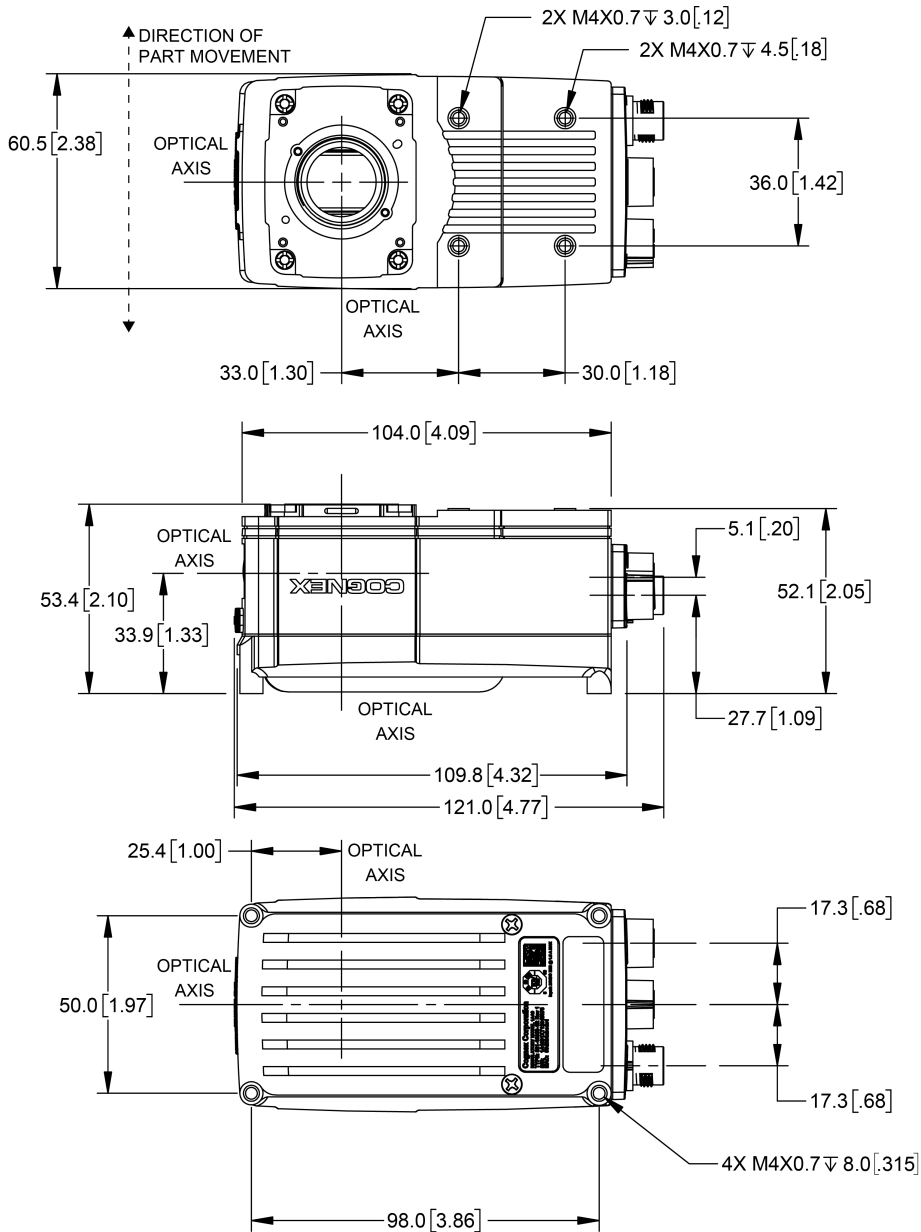

## 9902L Vision System with Cover (COV-7000-CMNT-LG)

**Note:**



- Dimensions are in millimeters [inches] and are for reference purposes only.
- All specifications are for reference purposes only and can change without notice.

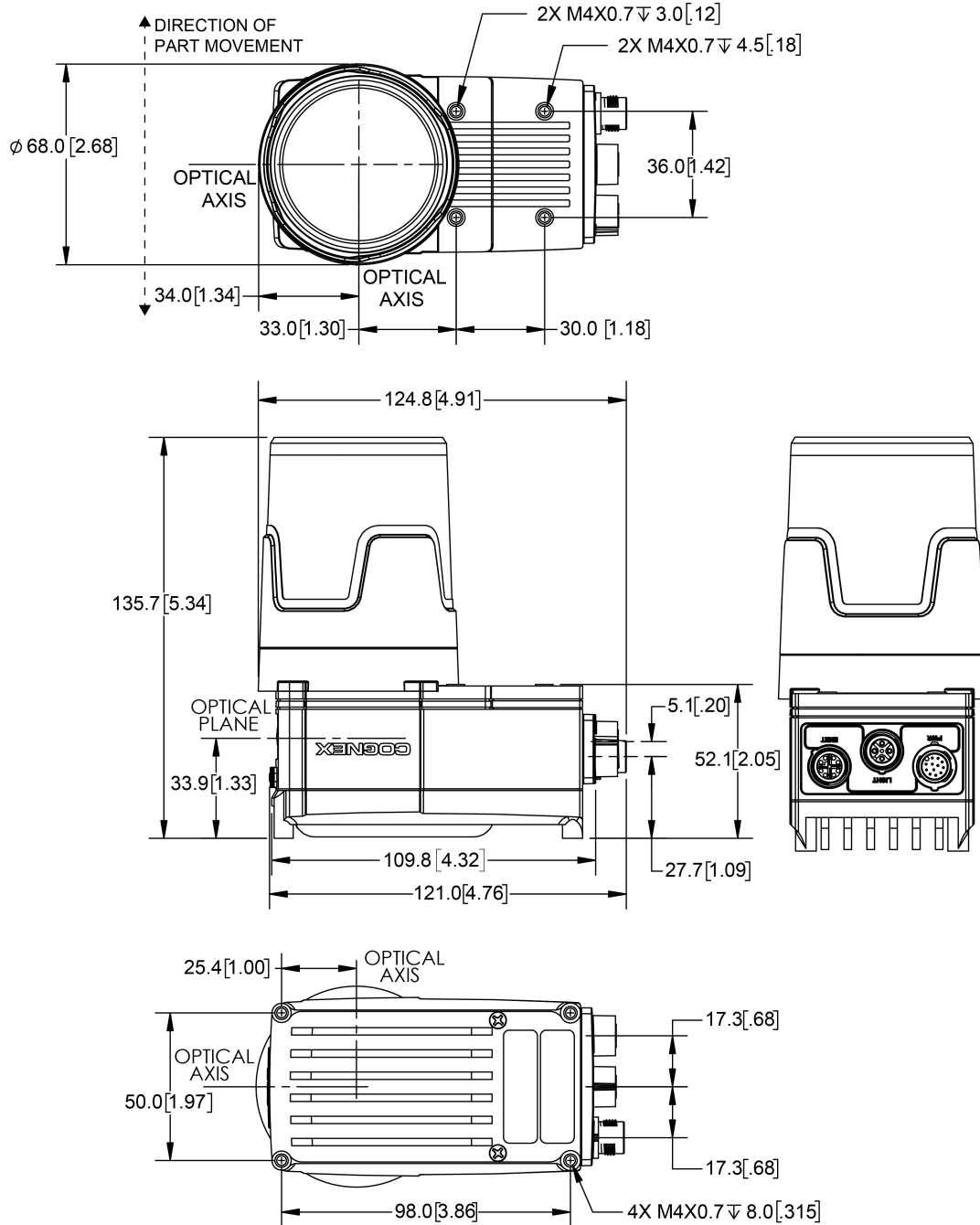

# 9902L Vision System with Cover (COV-7000-CMNT-LG) and Extender (COV-7000-CMNT-LGX)

**Note:**



- Dimensions are in millimeters [inches] and are for reference purposes only.
- All specifications are for reference purposes only and can change without notice.

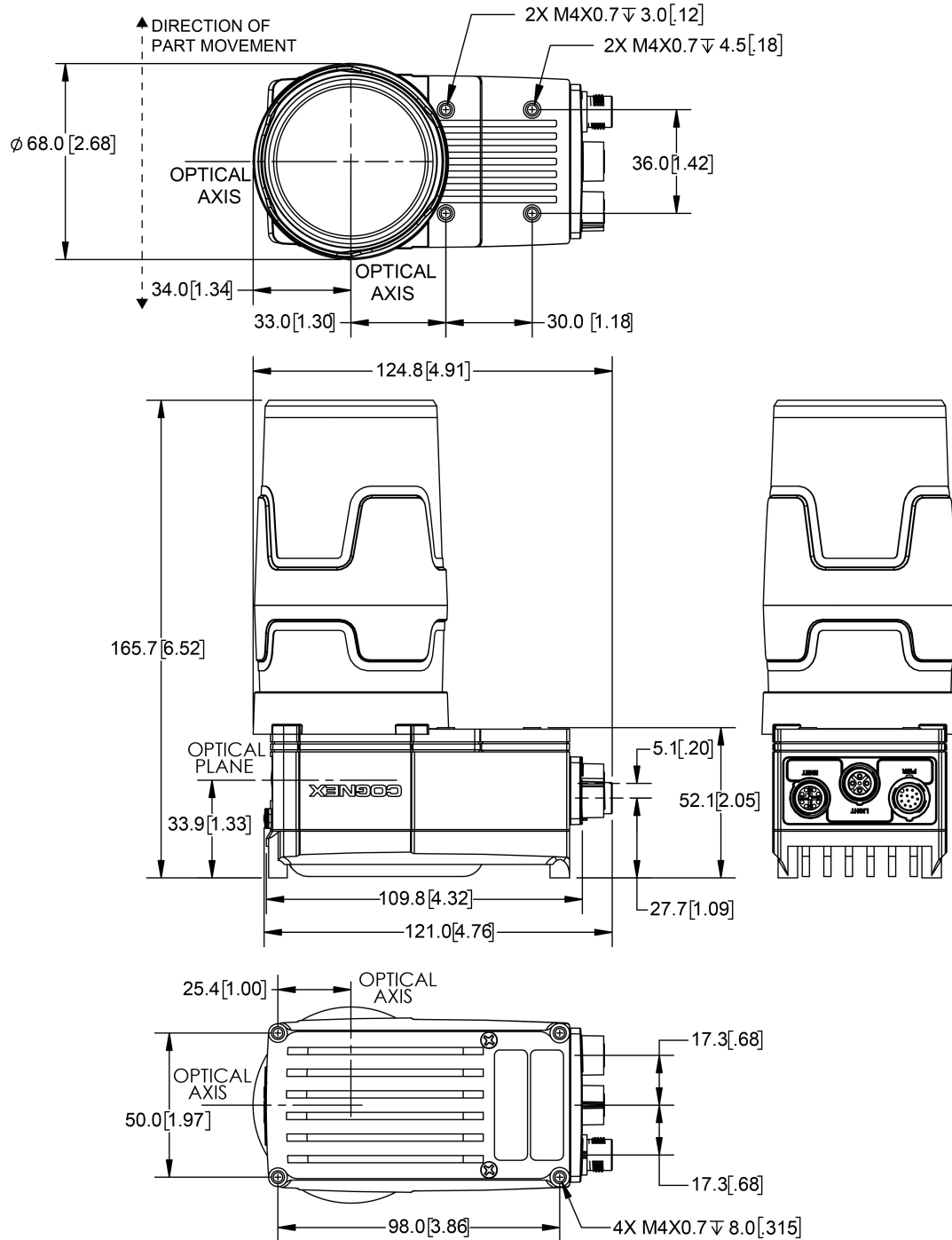

## 9902L C-Mount Lens Clearance Dimensions

**Note:**

- For the In-Sight 9902L vision system, the C-Mount lens has the following restrictions:
  - Maximum thread length is 5.25mm.
  - The C-Mount lens threads and body cannot protrude more than 6.5mm in length into the vision system when screwed in, unless the diameter of the back lens is smaller than 19.25mm. If the C-Mount lens threads and body protrude more than 6.5mm, you can add a spacer between the lens and vision system. However, the spacer decreases the working distance.
- Dimensions are in millimeters [inches] and are for reference purposes only.
- All specifications are for reference purposes only and can change without notice.

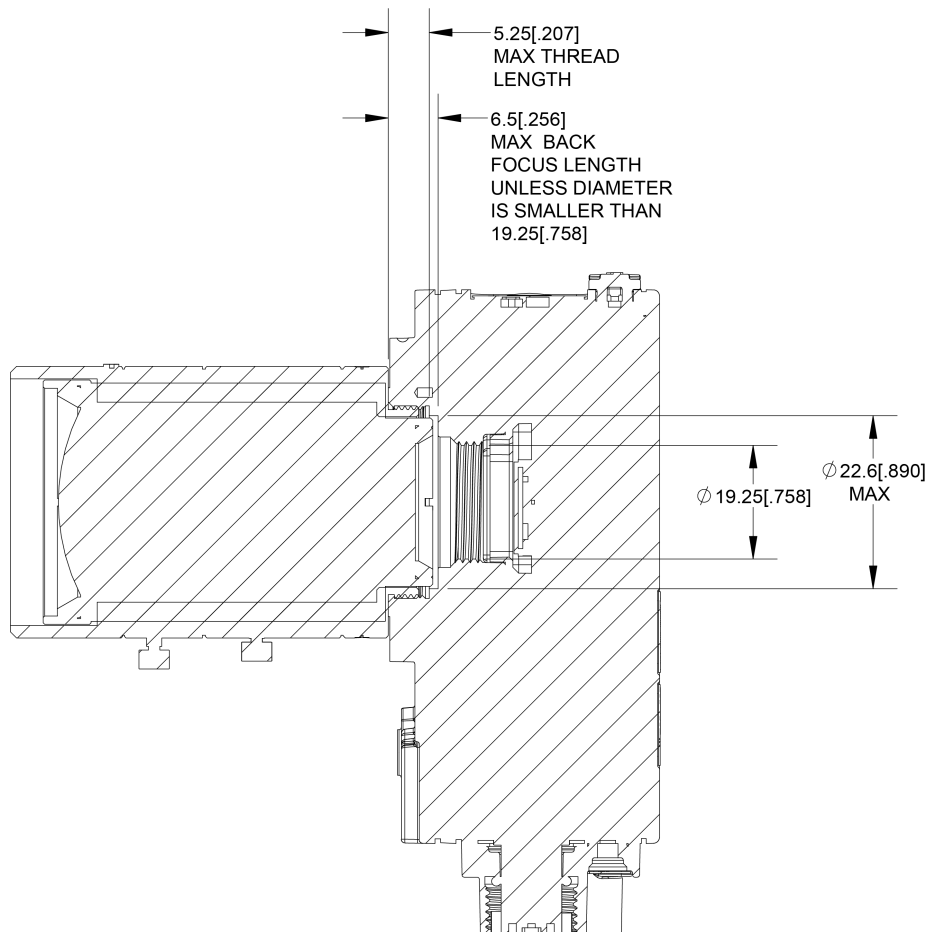

## 9912 Vision System Dimensions

**Note:**



- Dimensions are in millimeters [inches] and are for reference purposes only.
- All specifications are for reference purposes only and can change without notice.

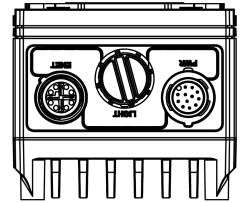
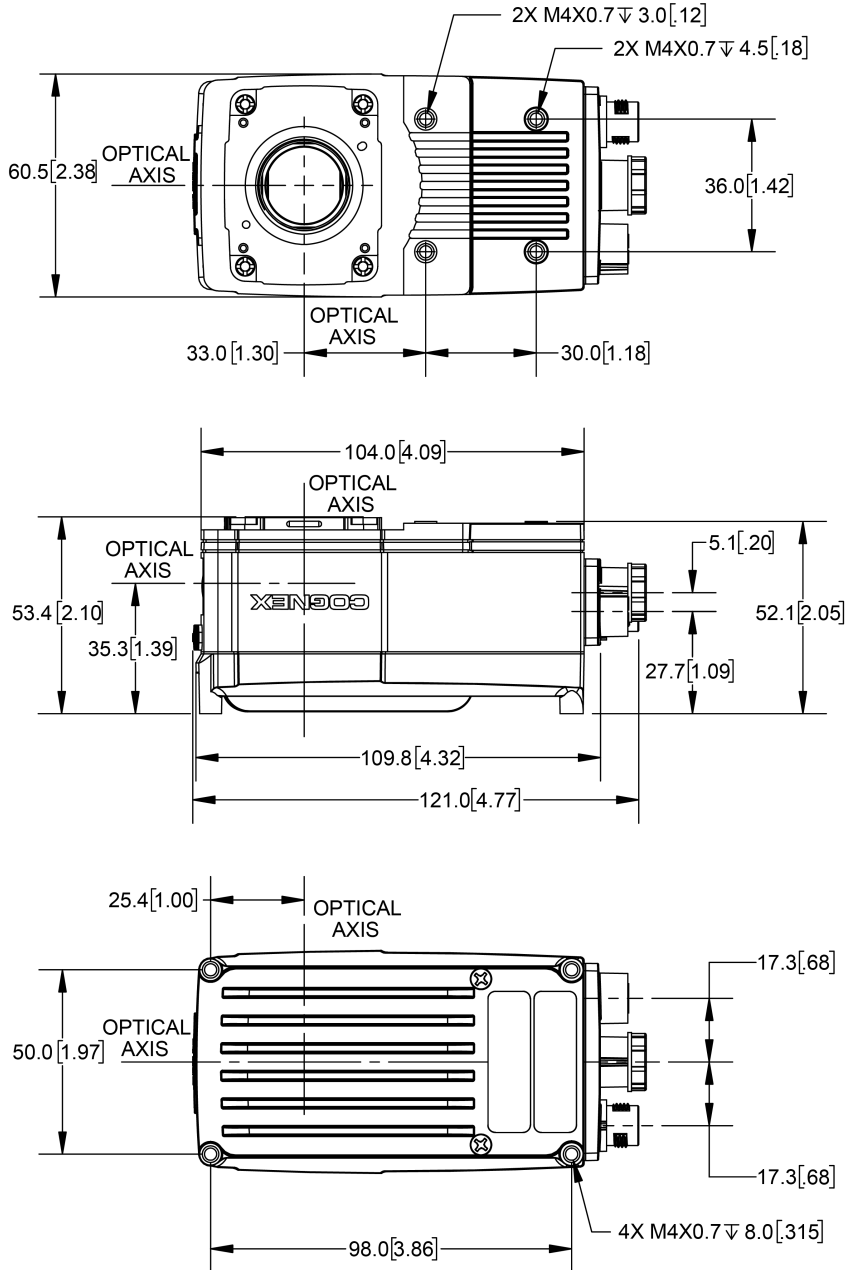

## 9912 Vision System with Cover (COV-7000-CMNT-LG)

**Note:**



- Dimensions are in millimeters [inches] and are for reference purposes only.
- All specifications are for reference purposes only and can change without notice.

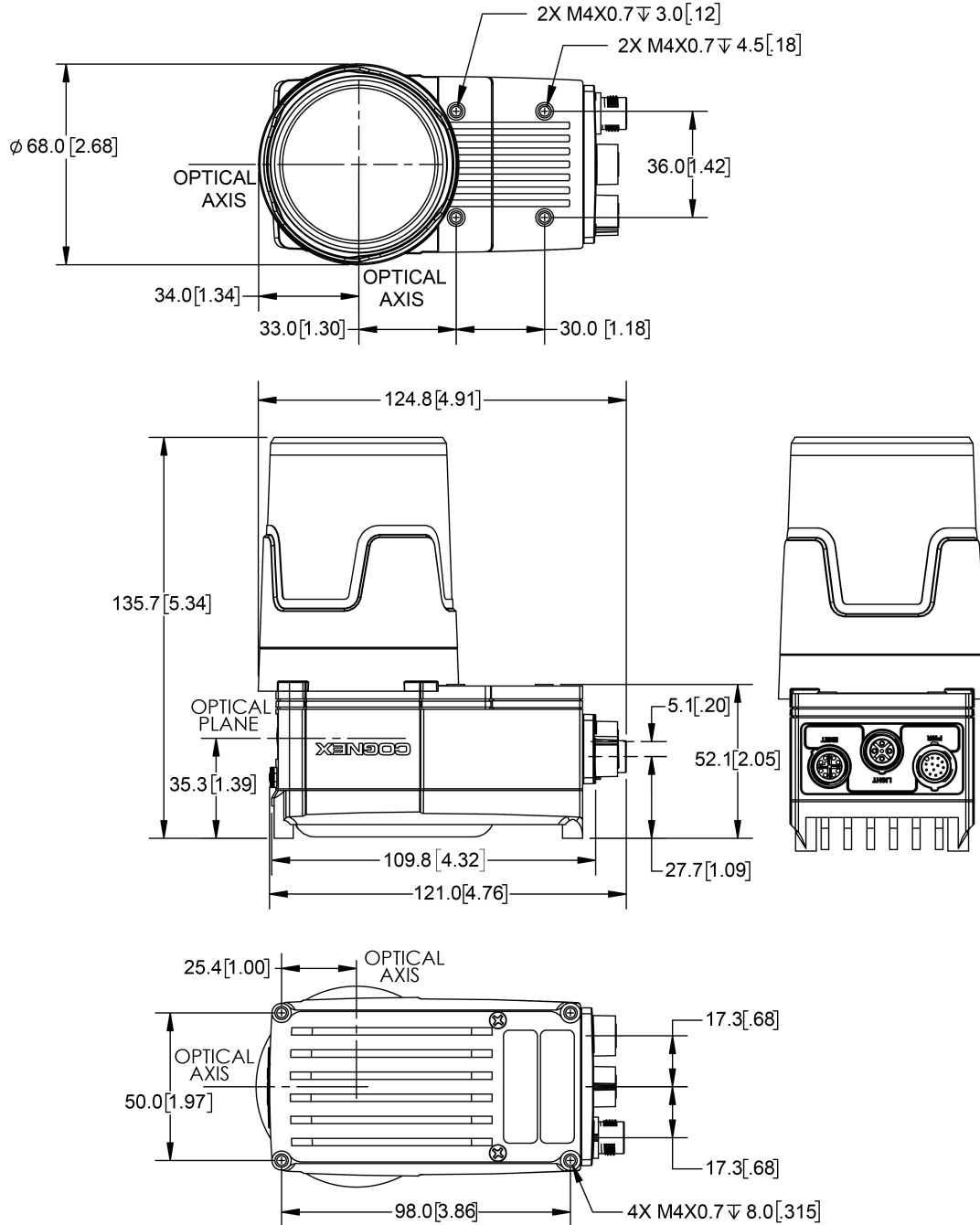

## 9912 Vision System with Cover (COV-7000-CMNT-LG) and Extender (COV-7000-CMNT-LGX)

**Note:**



- Dimensions are in millimeters [inches] and are for reference purposes only.
- All specifications are for reference purposes only and can change without notice.

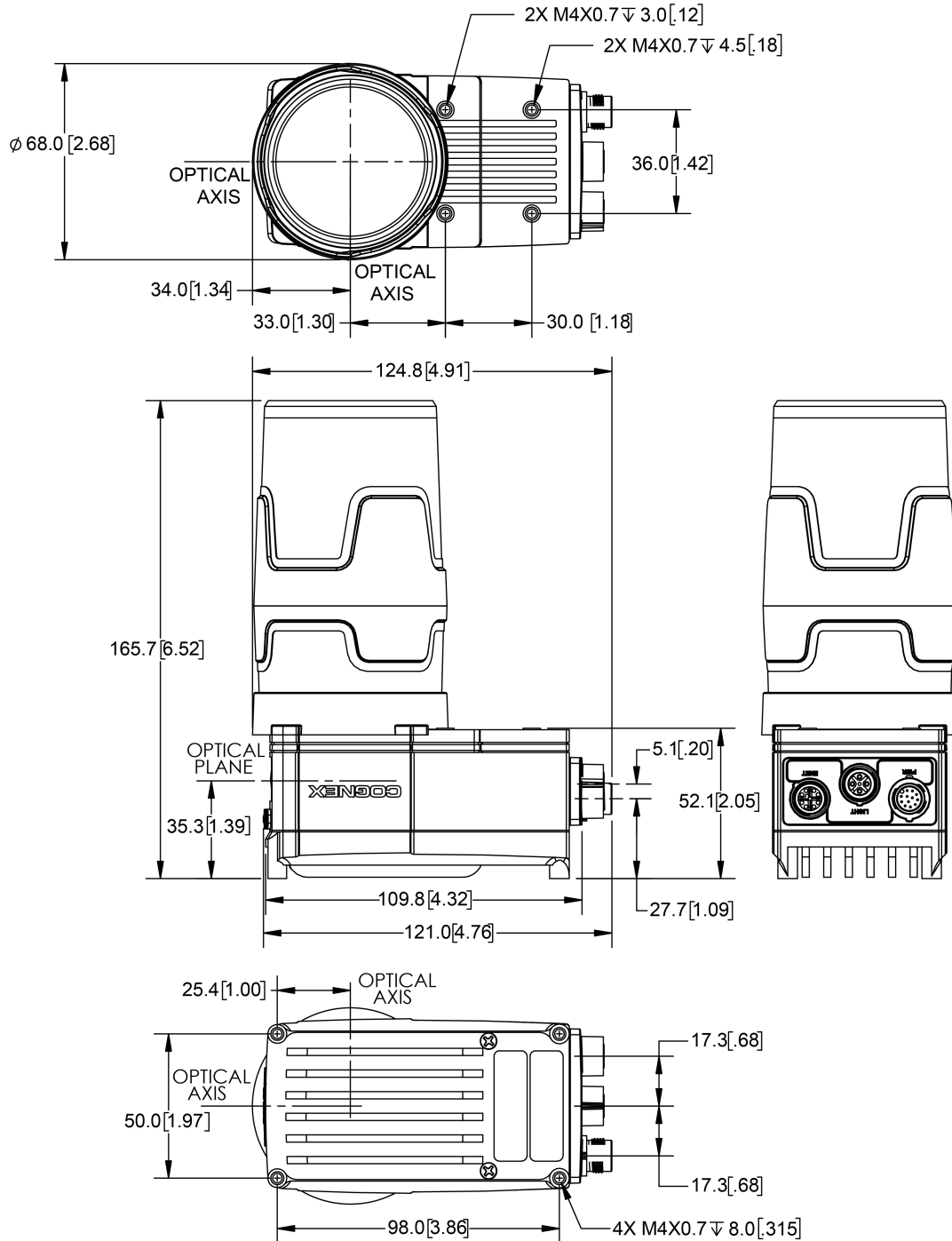

# Cleaning and Maintenance

## Clean the Housing

To clean the outside of the vision system housing, use a small amount of mild detergent cleaner or isopropyl alcohol on a cleaning cloth. Do not pour the cleaner on the vision system housing.

---

 **CAUTION:** Do not attempt to clean any In-Sight product with harsh or corrosive solvents, including lye, methyl ethyl ketone (MEK) or gasoline.

---

## Clean the Image Sensor Window

To remove dust from the outside of the image sensor window, use a pressurized air duster. The air must be free of oil, moisture or other contaminants that could remain on the glass and possibly degrade the image. Do not touch the glass window. If oil or smudges remain, use a cotton bud and alcohol (ethyl, methyl, or isopropyl) to clean the window. Do not pour the alcohol on the window.

## Clean the Cover

To remove dust from the lens cover, use a pressurized air duster. The air must be free of oil, moisture or other contaminants that could remain on the lens cover. To clean the plastic window of the lens cover, use a small amount of isopropyl alcohol on a cleaning cloth. Do not scratch the plastic window. Do not pour the alcohol on the plastic window.

