

In-Sight[®] 2000 Series Vision Sensor Reference Guide



2019 May 07
Revision: 5.7.0.4

Legal Notices

The software described in this document is furnished under license, and may be used or copied only in accordance with the terms of such license and with the inclusion of the copyright notice shown on this page. Neither the software, this document, nor any copies thereof may be provided to, or otherwise made available to, anyone other than the licensee. Title to, and ownership of, this software remains with Cognex Corporation or its licensor. Cognex Corporation assumes no responsibility for the use or reliability of its software on equipment that is not supplied by Cognex Corporation. Cognex Corporation makes no warranties, either express or implied, regarding the described software, its merchantability, non-infringement or its fitness for any particular purpose.

The information in this document is subject to change without notice and should not be construed as a commitment by Cognex Corporation. Cognex Corporation is not responsible for any errors that may be present in either this document or the associated software.

Companies, names, and data used in examples herein are fictitious unless otherwise noted. No part of this document may be reproduced or transmitted in any form or by any means, electronic or mechanical, for any purpose, nor transferred to any other media or language without the written permission of Cognex Corporation.

Copyright © 2018. Cognex Corporation. All Rights Reserved.

Portions of the hardware and software provided by Cognex may be covered by one or more U.S. and foreign patents, as well as pending U.S. and foreign patents listed on the Cognex web site at: cognex.com/patents.

The following are registered trademarks of Cognex Corporation:

Cognex, 2DMAX, Advantage, AlignPlus, Assemblyplus, Check it with Checker, Checker, Cognex Vision for Industry, Cognex VSOC, CVL, DataMan, DisplayInspect, DVT, EasyBuilder, Hotbars, IDMax, In-Sight, Laser Killer, MVS-8000, OmniView, PatFind, PatFlex, PatInspect, PatMax, PatQuick, SensorView, SmartView, SmartAdvisor, SmartLearn, UltraLight, Vision Solutions, VisionPro, VisionView

The following are trademarks of Cognex Corporation:

The Cognex logo, 1DMax, 3D-Locate, 3DMax, BGAll, CheckPoint, Cognex VSoC, CVC-1000, FFD, iLearn, In-Sight (design insignia with cross-hairs), In-Sight 2000, InspectEdge, Inspection Designer, MVS, NotchMax, OCRMax, PatMax RedLine, ProofRead, SmartSync, ProfilePlus, SmartDisplay, SmartSystem, SMD4, VisiFlex, Xpand



Portions copyright © Microsoft Corporation. All rights reserved.

Portions copyright © MadCap Software, Inc. All rights reserved.

Other product and company trademarks identified herein are the trademarks of their respective owners.

Regulations/Conformity

Note: For the most current CE declaration and regulatory conformity information, see the Cognex support site: cognex.com/support.

Safety and Regulatory	
Manufacturer	Cognex Corporation One Vision Drive Natick, MA 01760 USA
	In-Sight 2000 Series Vision Sensor: Regulatory Model R00039 In-Sight 2000 Mini Series Vision Sensor: Regulatory Model 1ABD This is a class A product. In a domestic environment this product may cause radio interference in which case the user may be required to take immediate measures. This equipment complies with the essential requirements of the EU Directive 2014/30/EU. Declarations are available from your local representative.
EU RoHS	Compliant to the most recent applicable directive.
FCC	FCC Part 15, Class A This equipment has been tested and found to comply with the limits for a Class A digital device, pursuant to part 15 of the FCC Rules. These limits are designed to provide reasonable protection against harmful interference when the equipment is operated in a commercial environment. This equipment generates, uses, and can radiate radio frequency energy and, if not installed and used in accordance with the instruction manual, may cause harmful interference to radio communications. Operation of this equipment in a residential area is likely to cause harmful interference in which case the user will be required to correct the interference at his own expense.
Korea 	R-REM-CGX-R00039 MSIP-REM-CGX-DM260 MSIP-REM-CGX-IS2000 This device is certified for office use only and if used at home, there can be frequency interference problems.
Canadian EMC Compliance	This Class A digital apparatus complies with Canadian ICES-003. Cet appareil numérique de la classe A est conforme à la norme NMB-003 du Canada.
UL and CUL NRTL Statement 	UL 60950-1, 2nd Edition, 2014-10-14 CAN/CSA C22.2 No. 60950-1-07, 2nd Edition, 2014-10
CB	UL IEC/EN 60950-1. CB report available upon request.

China RoHS



Part Name 部件名称	Hazardous Substances 有害物质					
	Lead (Pb) 铅	Mercury (Hg) 汞	Cadmium (Cd) 镉	Hexavalent Chromium (Cr (VI)) 六价铬	Polybrominated biphenyls (PBB) 多溴联苯	Polybrominated diphenyl ethers (PBDE) 多溴二苯醚
Regulatory Model R00039 Regulatory Model 1ABD	X	O	O	O	O	O

This table is prepared in accordance with the provisions of SJ/T 11364.
这个标签是根据SJ/T 11364 的规定准备的。

O: Indicates that said hazardous substance contained in all of the homogeneous materials for this part is below the limit requirement of GB / T26572 - 2011.

表示本部件所有均质材料中含有的有害物质低于GB / T26572 - 2011 的限量要求。

X: Indicates that said hazardous substance contained in at least one of the homogeneous materials used for this part is above the limit requirement of GB / T26572 - 2011.

表示用于本部件的至少一种均质材料中所含的危害物质超过GB / T26572 - 2011 的限制要求。

For European Community Users

Cognex complies with Directive 2012/19/EU OF THE EUROPEAN PARLIAMENT AND OF THE COUNCIL of 4 July 2012 on waste electrical and electronic equipment (WEEE).

This product has required the extraction and use of natural resources for its production. It may contain hazardous substances that could impact health and the environment, if not properly disposed.

In order to avoid the dissemination of those substances in our environment and to diminish the pressure on the natural resources, we encourage you to use the appropriate take-back systems for product disposal. Those systems will reuse or recycle most of the materials of the product you are disposing in a sound way.



The crossed out wheeled bin symbol informs you that the product should not be disposed of along with municipal waste and invites you to use the appropriate separate take-back systems for product disposal.

If you need more information on the collection, reuse, and recycling systems, please contact your local or regional waste administration.

You may also contact your supplier for more information on the environmental performance of this product.

Precautions

To reduce the risk of injury or equipment damage, observe the following precautions when you install the Cognex product:

- This device requires the use of an LPS or NEC class 2 power supply. Any other voltage creates a risk of fire or shock and can damage the components. Applicable national and local wiring standards and rules must be followed.
- Route cables and wires away from high-current wiring or high-voltage power sources to reduce the risk of damage or malfunction from the following causes: over-voltage, line noise, electrostatic discharge (ESD), power surges, or other irregularities in the power supply.
- Do not install Cognex products where they are exposed to environmental hazards such as excessive heat, dust, moisture, humidity, impact, vibration, corrosive substances, flammable substances, or static electricity.
- Do not expose the image sensor to laser light. Image sensors can be damaged by direct, or reflected, laser light. If your application requires laser light that might strike the image sensor, use a lens filter at the corresponding laser wavelength. For suggestions, contact your local integrator or application engineer.
- Include service loops with cable connections. Changes or modifications not expressly approved by the party responsible for regulatory compliance could void the user's authority to operate the equipment.
- Ensure that the cable bend radius begins at least six inches from the connector. Cable shielding can be degraded or cables can be damaged or wear out faster if a service loop or bend radius is tighter than 10X the cable diameter.
- This device is certified for office use only and if used at home, there can be frequency interference problems.
- This device should be used in accordance with the instructions in this manual.
- Applicable national and local wiring standards and rules must be followed.
- All specifications are for reference purposes only and can change without notice.

Symbols

The following symbols indicate safety precautions and supplemental information:

 **WARNING:** This symbol indicates a hazard that could cause death, serious personal injury or electrical shock.

 **CAUTION:** This symbol indicates a hazard that could result in property damage.

 **Note:** This symbol indicates additional information about a subject.

 **Tip:** This symbol indicates suggestions and shortcuts that might not otherwise be apparent.

Table of Contents

Legal Notices	2
Regulations/Conformity	3
China RoHS	4
For European Community Users	4
Precautions	5
Symbols	6
Table of Contents	7
Introduction	9
Support	9
Standard Components	9
Options and Accessories	10
In-Sight 2000 Vision Sensor Lenses, Lights, Filters and Covers	10
In-Sight 2000 Mini Vision Sensor Lights, Filters and Covers	11
Cables	12
Power Supplies	12
Mounting Brackets	12
I/O Module	13
Replacement Kit	13
Connectors and Indicators	14
Installation	15
Install the In-Sight 2000 Vision Sensor	15
Mounting Configurations	15
Mount the Vision Sensor	18
Set the Focus Position (S-Mount/M12 Lens Configuration)	19
Replace the M12 Lens (S-Mount/M12 Lens Configuration)	20
Install the Lens Filter (S-Mount/M12 Lens Configuration)	22
Replace the LED Ring Light (S-Mount/M12 Lens Configuration)	24
Install the In-Sight 2000 Mini Vision Sensor	26
Mount the Vision Sensor	26
Mounting Configurations	27
Replace the LED Light	29
Install the Lens Filter	31
Working Distance and Field of View	33
In-Sight 2000 Vision Sensor (S-Mount/M12 Lens Configuration)	33
In-Sight 2000 Vision Sensor (Liquid Lens Configuration)	35
In-Sight 2000 Mini Vision Sensor	37
Connect the Ethernet Cable	39
Connect the Breakout Cable	39
Connect the CIO-1400 I/O Expansion Module (Optional)	40
Specifications	42
In-Sight 2000 Vision Sensor Specifications	42
In-Sight 2000 Mini Vision Sensor Specifications	44
Acquisition Trigger	46
General-Purpose Input	47

High-Speed Outputs	48
High-Speed Output Wiring	49
Breakout Cable Specifications	50
Ethernet Cable Specifications	51
I/O Module Cable Specifications	52
In-Sight 2000 Vision Sensor Dimensions	53
In-Sight 2000 Mini Vision Sensor Dimensions (With 6.2 mm Lens)	54
In-Sight 2000 Mini Vision Sensor Dimensions (With 16 mm Lens)	55
Cleaning/Maintenance	56
Clean the Vision Sensor Housing	56
Clean the Vision Sensor Image Sensor Window	56
Clean the Vision Sensor Lens Cover	56

Introduction

The In-Sight[®] 2000 is a compact, network-ready, stand-alone machine vision sensor used for automated inspection and measurement applications on the factory floor. All models can be easily programmed remotely over a network using an intuitive user interface.

Support

Resources available to assist you in using the vision sensor:



- The *In-Sight[®] Explorer Help* and *EasyBuilder Help* files, provided with In-Sight Explorer software.
- The In-Sight online support site: <http://www.cognex.com/Support/InSight>.

Standard Components

Note:





- Cables are sold separately.
- If a standard component is missing or damaged, immediately contact your Cognex Authorized Service Provider (ASP) or Cognex Technical Support.

Product		Components
	In-Sight 2000 Vision Sensor	<ol style="list-style-type: none"> 1. Optics module, featuring high brightness LED ring light and S-Mount/M12 lens, or liquid lens with auto-focus capability 2. Main module, including sensor and CPU 3. I/O connector module
	In-Sight 2000 Mini Vision Sensor	<ol style="list-style-type: none"> 1. Optics module, featuring LED light and liquid lens with auto-focus capability 2. Main module, including sensor and CPU 3. I/O connector module

Options and Accessories

In-Sight 2000 Vision Sensor Lenses, Lights, Filters and Covers





Lens Options



Lens, M12, 3.6 mm (LM12-03-01)	
Lens, M12, 6 mm (LM12-06-01)	
Lens, M12, 8 mm (LM12-08-01)	
Lens, M12, 12 mm (LM12-12-01)	
Lens, M12, 16 mm (LM12-16-01)	
Lens, M12, 25 mm (LM12-25-01)	
Lens Spacer, M12, 16 mm (LM12-SPACER-16-0)	
Lens Spacer, M12, 25 mm (LM12-SPACER-25-01)	

Lights

High Brightness Red LED Ring Light (IFS-2000-HBRING-RD)	
High Brightness White LED Ring Light (IFS-2000-HBRING-WH)	
High Brightness Blue LED Ring Light (IFS-2000-HBRING-BL)	
High Brightness Near IR LED Ring Light (IFS-2000-HBRING-IR)	

Filters and Covers

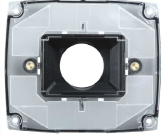
Red Bandpass Filter, 635 nm (IMRF-2000-BP635)	
Blue Bandpass Filter, 470 nm (IMBF-2000-BP470)	
IR Bandpass Filter, 850 nm (IMIF-2000-BP850)	
Polarizer Cover (IMPF-2000-POLAR)	

Replacement Cover (IFS-2000-HBRING-CV)	
Clear Cover (IFS-2000-HBRING-CC)	

In-Sight 2000 Mini Vision Sensor Lights, Filters and Covers

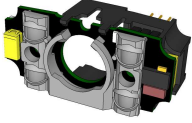
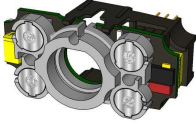

Lights

Red LED Light for 6.2 mm Lens (DM150-LED-RED)	
White LED Light for 6.2 mm Lens (DM150-LED-WHT)	
Blue LED Light for 6.2 mm Lens (DM150-LED-BLU)	
High Powered Red LED Light for 16 mm Lens (DM260-LED-RED-HP)	
High Powered White LED Light for 16 mm Lens (DM260-LED-WHT-HP)	



Filters and Covers

Blue Bandpass Filter (DM150-BP470)	
Red Bandpass Filter (DM150-BP635)	
Clear Cover for 6.2 mm Lens (DM150-CVR-CLR)	
Clear Cover for 6.2 mm Lens, ESD Safe (DM150-CVR-ESD)	
Polarized Cover for 6.2 mm Lens (DM260-LENS-62CVR-F)	
Extended Cover for 16 mm Lens, Un-polarized (DM260-LENS-16CVR)	
Extended Cover for 16 mm Lens, Half-polarized (DM260-LENS-16CVR-P)	
Extended Cover for 16 mm Lens, Fully Polarized (DM260-LENS-16CVR-F)	

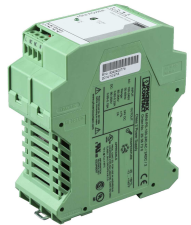

Cables

Breakout Cable, M12-12 to Flying Lead (CCB-PWRIO-xx) (xx specifies length: 5m, 10m, 15m)	
Ethernet X-coded M12-8 to RJ-45 Cable (CCB-84901-2001-xx) (xx specifies length: 2m, 5m, 10m, 15m, 30m)	
I/O Module Cable M12-12 to DB15 (CCB-PWRIO-MOD-xx) (xx specifies length: 2m, 5m)	

Power Supplies

Cognex 24VDC Power Supply (ACC-24I)	
North America Power Cord (CBLI-24VDUS)	
Japan Power Cord (CBLI-24VDJP)	
United Kingdom Power Cord (CBLI-24VDUK)	
Europe Power Cord (CBLI-24VDEU)	

Mounting Brackets

Universal Mounting Bracket (DM100-UBRK-000)	
Pivot Mounting Bracket (DM100-PIVOTM-00)	

Flat Surface Mounting Plate Adapter (BKT-2000-ADAPT-00)



I/O Module

In-Sight CIO-1400 I/O Expansion Module (CIO-1400)¹



Replacement Kit

Screws, Washers, and Caps Kit (IS2000-CAPS-KIT)

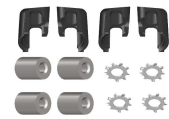

¹ The CIO-1400 I/O expansion module supports In-Sight 2000 series vision sensors with firmware version 5.3.0 and higher.

Connectors and Indicators



Connector	Function
Ethernet connector (left)	Connects the Ethernet cable. For more information, refer to Ethernet Cable Specifications on page 51 .
Power, I/O and RS-232 connector (right)	Connects the Breakout cable, which provides connections to an external power supply, the acquisition trigger input, general-purpose inputs, high-speed outputs, and RS-232 serial communications. For more information, refer to Breakout Cable Specifications on page 50 . Alternately, this connector is used to attach the I/O Module cable to a compatible In-Sight I/O module, which adds general-purpose discrete I/O. For more information, refer to I/O Module Cable Specifications on page 52 .



Indicator	Function
	Power LED The green LED illuminates to indicate that the vision sensor is powered on.
	Status LED Yellow when active. User-configurable (LED 5 Yellow).
	Pass/Fail LED Green (pass) or red (fail) when active. User configurable (LED 4 Green/LED 4 Red).
	Network LED The yellow LED flashes to indicate network activity.
	Error LED Red when active.
	Trigger button Manually triggers an image acquisition when the vision sensor is either: <ul style="list-style-type: none"> • Online and the Trigger type is configured as Manual • Offline
	Tune button Unsupported.

Installation

Read this section to learn how the vision sensor connects to its standard components and accessories. For a list of options and accessories, contact your Cognex sales representative.

Note:

- Disregard any references to In-Sight Explorer software in the In-Sight 2000 Series Vision Sensor Reference Guide. Instead, configure the AS200 Alignment Sensor with the AS200 Alignment Sensor software as described in the "AS200 Alignment Sensor User Interface" topic in this document.
- Cables are sold separately.
- If a standard component is missing or damaged, immediately contact your Cognex Authorized Service Provider (ASP) or Cognex Technical Support.



CAUTION: All cable connectors are keyed to fit the connectors on the vision sensor. Do not force the connections or damage may occur.

Install the In-Sight 2000 Vision Sensor

Mounting Configurations

Perform the following steps to change between the in-line and right-angle configuration.

Note:

- Switching between the in-line and right-angle configuration is recommended only up to 10 times in the lifetime of the vision sensor.
- You can order a replacement kit (IS2000-CAPS-KIT) if you misplaced screws, washers or caps.



CAUTION: Make sure that no electrostatic charges are applied to the PCB (e.g., wear ESD shoes). If the main module is separated from the I/O connector module, make sure to reassemble them correctly. Otherwise, the IP rating can be compromised.

1. Verify that the 24VDC power supply is unplugged and not receiving power.
2. Carefully remove the screw covers, threaded cap nuts, and washers.

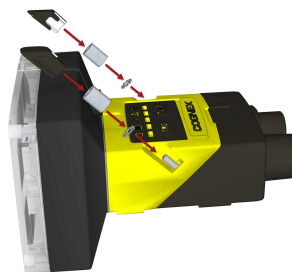

3. Detach the main module and the I/O connector module by firmly pulling them apart.

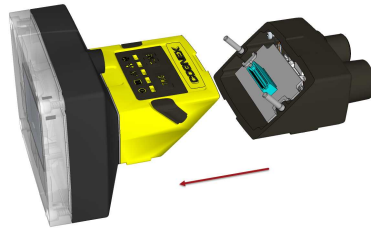

4. Change the orientation.



5. Reattach the I/O connector module to the main module.



6. Reinstall the washers and fasten the cap nuts.

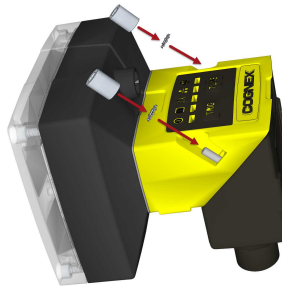

- After each cap nut has been fastened, torque to 0.12 Nm (1.06 in-lb) and reinstall the screw covers.

i Note: The left and right screw covers are different. Make sure to attach them correctly.

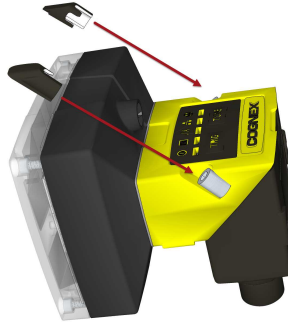

- Restore power to the 24VDC power supply and turn it on if necessary.

Mount the Vision Sensor

Mounting the vision sensor at a slight angle (15°) can reduce reflections and improve performance.

In-line Configuration

Use the universal mounting bracket (DM100-UBRK-000) with the mounting holes on the I/O connector module.

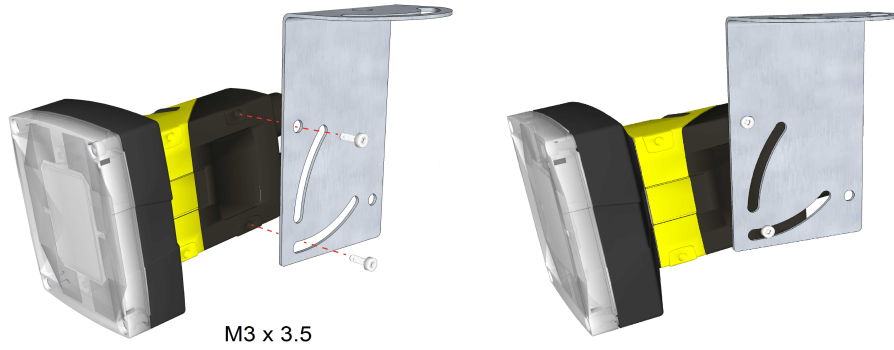

Right-Angle Configuration

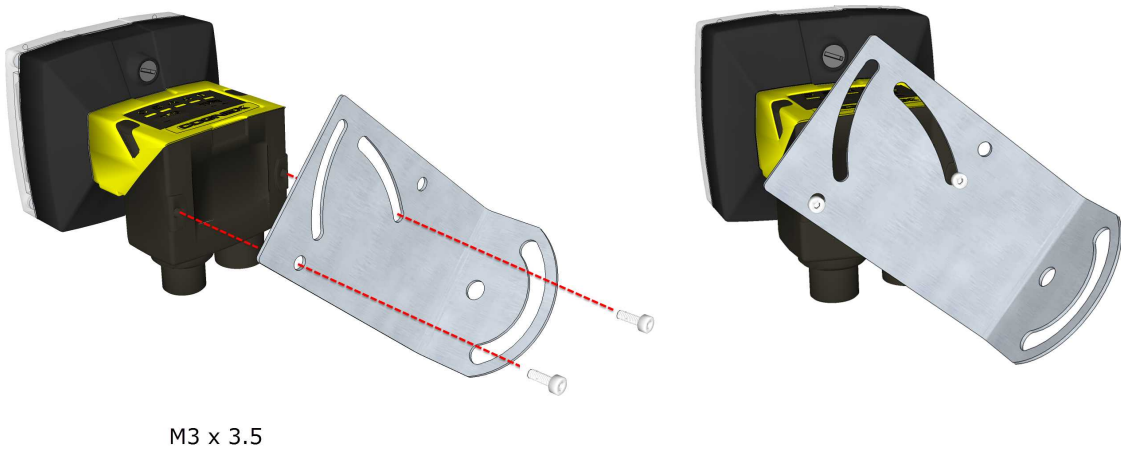

Set the Focus Position (S-Mount/M12 Lens Configuration)

Adjust the focus on the back of the light module. Turn the screw clockwise to focus at a shorter distance, and counter-clockwise to focus at a longer distance.

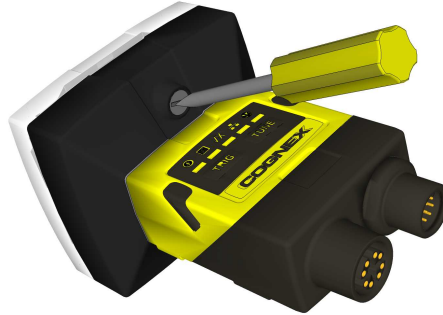

Replace the M12 Lens (S-Mount/M12 Lens Configuration)

1. Verify that the 24VDC power supply is unplugged and not receiving power.
2. Remove the four screws and the cover from the optics module.

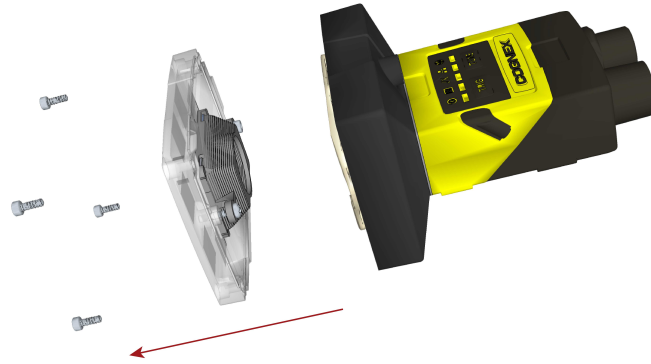

3. Move the lens to the furthest out position by turning the screw on the back of the light module clockwise.

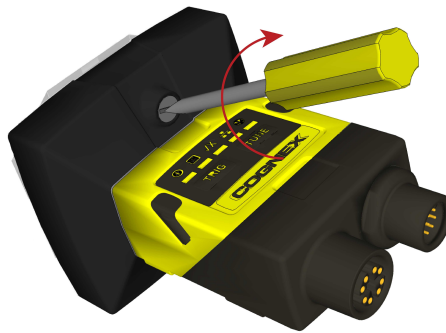

4. Using your fingers, turn the lens counter-clockwise to remove the lens.

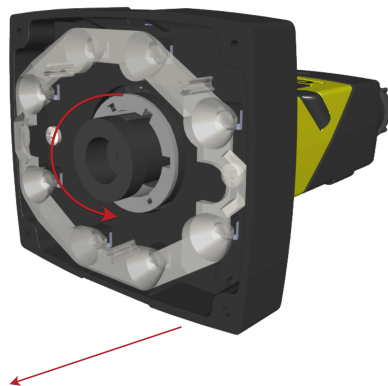

5. Insert the new lens and using your fingers, turn it clockwise to tighten the lens.

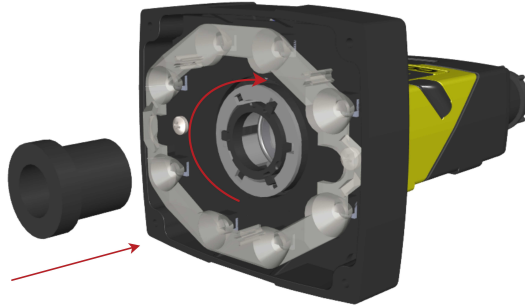

6. Reattach the cover. Tighten all four screws using a torque wrench; the maximum torque is 0.2 Nm (1.77 in-lb).

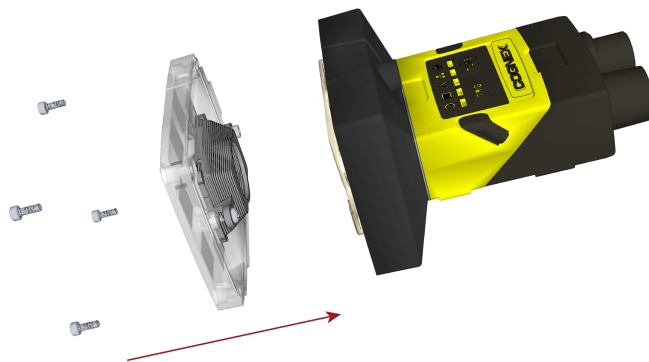

7. Restore power to the 24VDC power supply and turn it on if necessary.

Install the Lens Filter (S-Mount/M12 Lens Configuration)

Lens filters can be used to increase the contrast of images and improve the ability of the vision sensor to distinguish desired characteristics. Lens filters are available for purchase as an accessory.

1. Verify that the 24VDC power supply is unplugged and not receiving power.
2. Remove the four screws and the cover from the optics module.

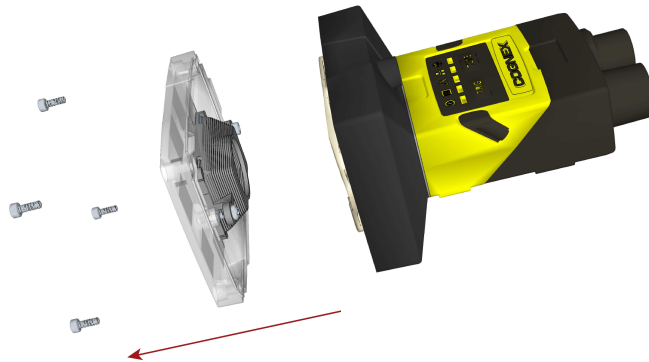

3. Unscrew the two screws on the filter holder and remove the filter holder from the cover.

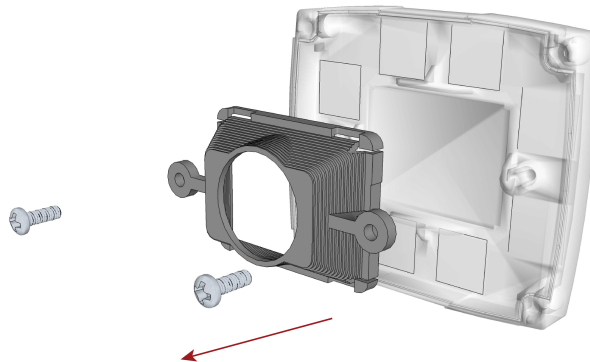

4. Hold the filter by the sides, then push the filter in until it is sitting firmly against the filter holder.

Note: Wear gloves when installing the filter to prevent leaving fingerprints on the surface of the filter.

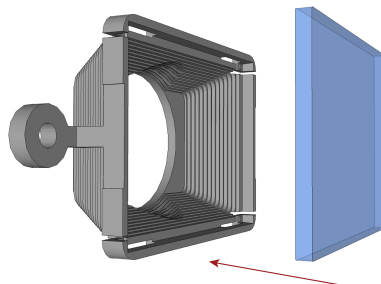

5. Reinstall the filter holder back to the cover. Tighten the screws until they stop turning.

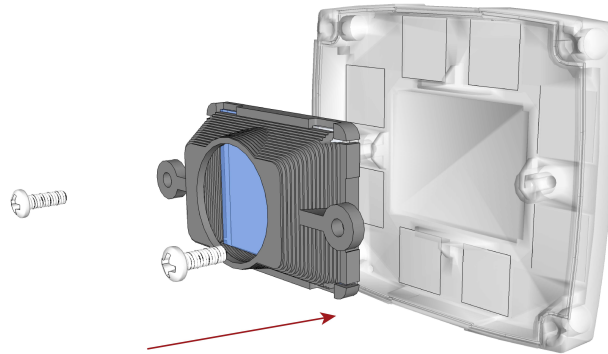

6. Reattach the cover. Tighten all four screws using a torque wrench; the maximum torque is 0.2 Nm (1.77 in-lb).

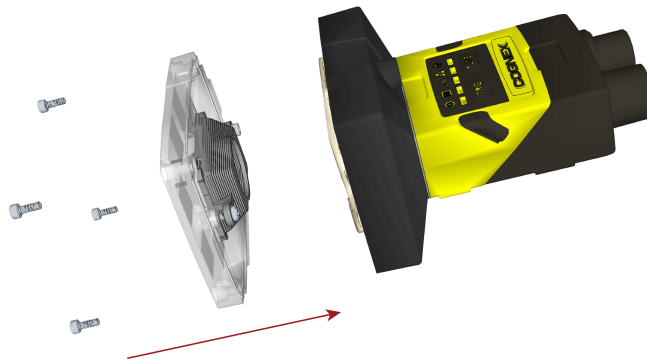

7. Restore power to the 24VDC power supply and turn it on if necessary.

Replace the LED Ring Light (S-Mount/M12 Lens Configuration)

1. Verify that the 24VDC power supply is unplugged and not receiving power.
2. Remove the four screws and the cover from the optics module.

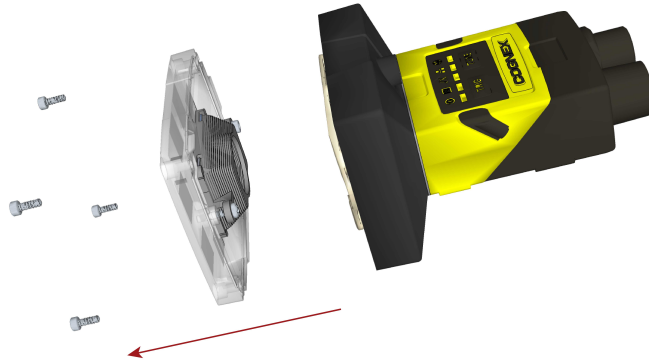

3. Using a screwdriver, loosen the two screws on the LED ring light.

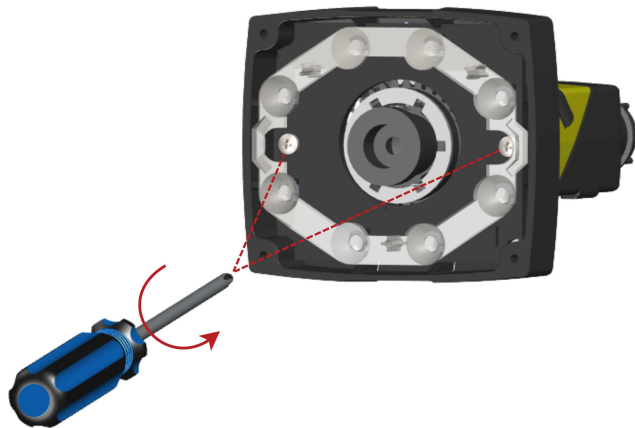

4. Remove the LED ring light.

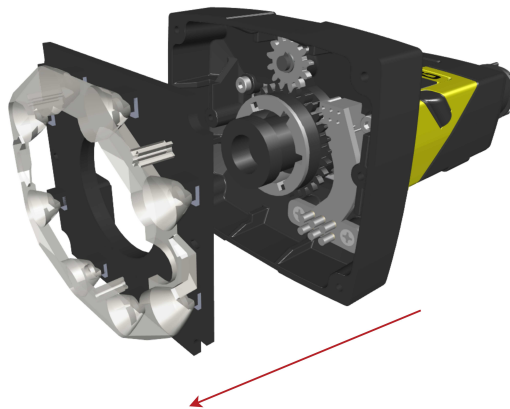

5. Carefully align the connector on the back of the new LED ring light with the pins on the vision sensor. Gently press down the LED ring light to the optics module.

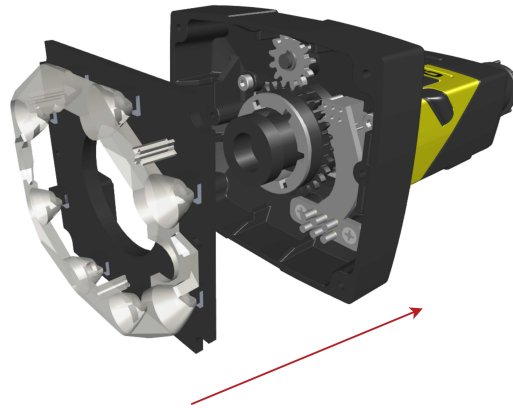

6. Using a screwdriver, tighten the screws until they stop turning.

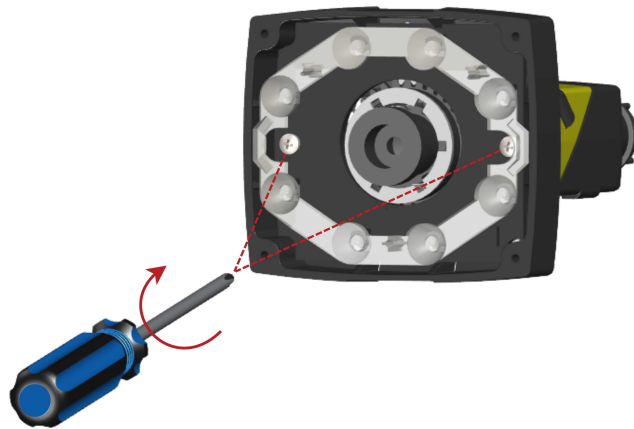

7. Reattach the cover. Tighten all four screws using a torque wrench; the maximum torque is 0.2 Nm (1.77 in-lb).

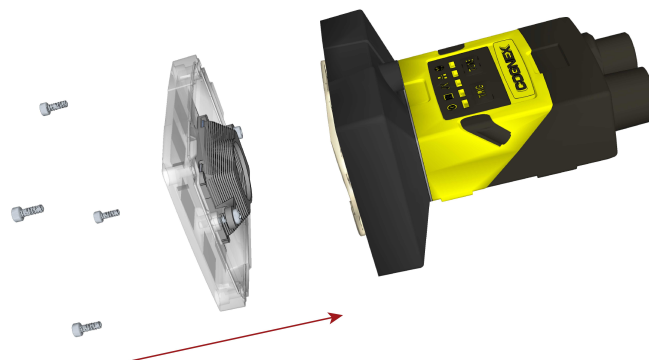

8. Restore power to the 24VDC power supply and turn it on if necessary.

Install the In-Sight 2000 Mini Vision Sensor

Mount the Vision Sensor

Mounting the In-Sight 2000 Mini at a slight angle (15°) can reduce reflections and improve reader performance.

In-line Configuration

Use the universal mounting bracket (DM100-UBRK-000) with the mounting holes on the I/O connector module.



Right-Angle Configuration



Mounting Configurations

Perform the following steps to change between the in-line and right-angle configuration.

Note:



- Switching between the in-line and right-angle configuration is recommended only up to 10 times in the lifetime of the vision sensor.
- You can order a replacement kit (IS2000-CAPS-KIT) if you misplaced screws, washers or caps.



CAUTION: Make sure that no electrostatic charges are applied to the PCB (e.g., wear ESD shoes). If the main module is separated from the I/O connector module, make sure to reassemble them correctly. Otherwise, the IP rating can be compromised.

1. Verify that the 24VDC power supply is unplugged and not receiving power.
2. Carefully remove the screw covers, threaded cap nuts and washers.

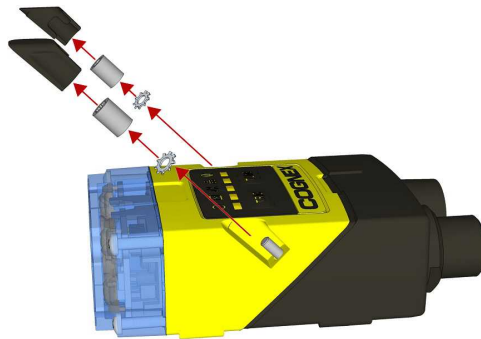

3. Detach the main module and the I/O connector module by firmly pulling them apart.

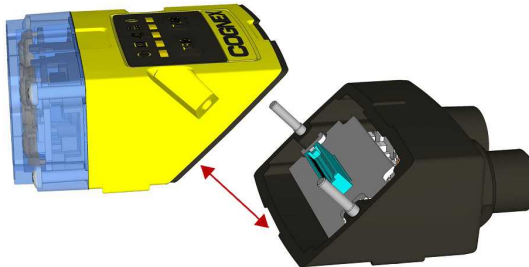

4. Change the orientation.

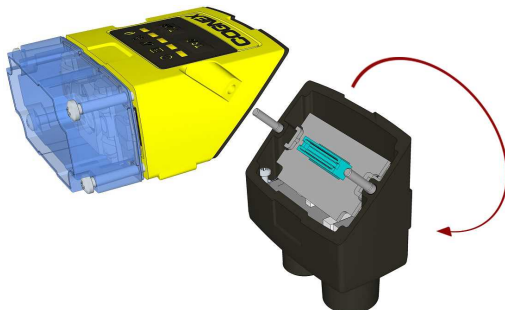

5. Reattach the I/O connector module to the main module.



6. Reinstall the washers and fasten the cap nuts.

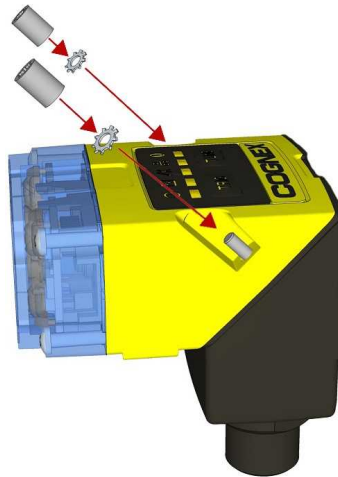

7. After each cap nut has been fastened, torque to 0.12 Nm (1.06 in-lb) and reinstall the screw covers.

Note: The left and right screw covers are different. Make sure to attach them correctly

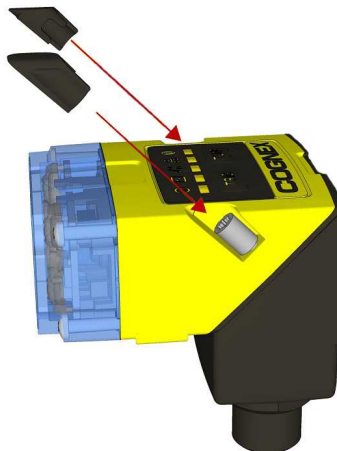

8. Restore power to the 24VDC power supply and turn it on if necessary.

Replace the LED Light

Perform the following steps to change the LED light.

1. Verify that the 24VDC power supply is unplugged and not receiving power.
2. Unscrew the four screws and take off the cover.

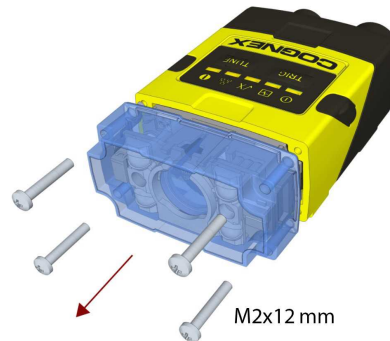

3. Remove the illumination module.

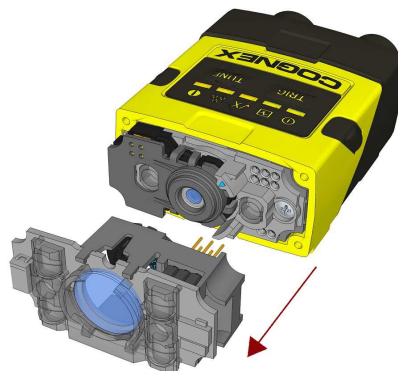

4. Attach a new illumination module. Make sure to attach the illumination module with the correct orientation.

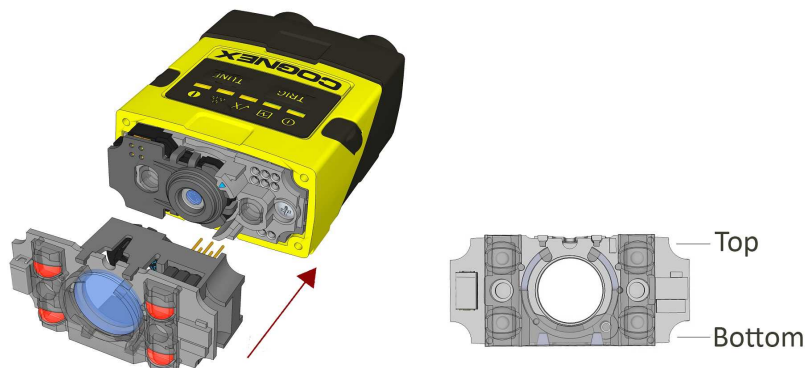

- Attach the cover. Observing the tightening sequence below, tighten all four screws to 9 Ncm (0.80 in-lb) using a torque wrench.

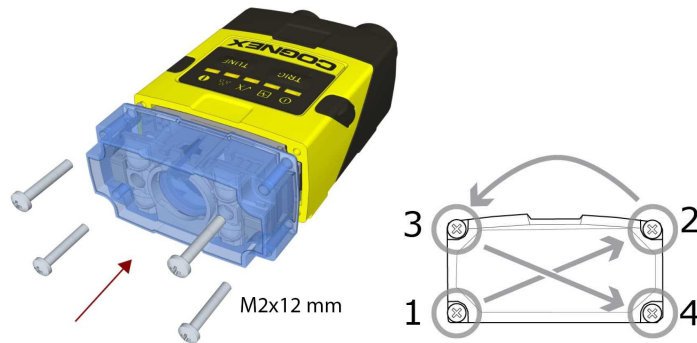

Note: The rib in the front cover must be oriented to the top side.

- Restore power to the 24VDC power supply and turn it on if necessary.

Install the Lens Filter

1. Verify that the 24VDC power supply is unplugged and not receiving power.
2. Unscrew the four M2 x 12 mm Phillips pan head screws and take off the cover.

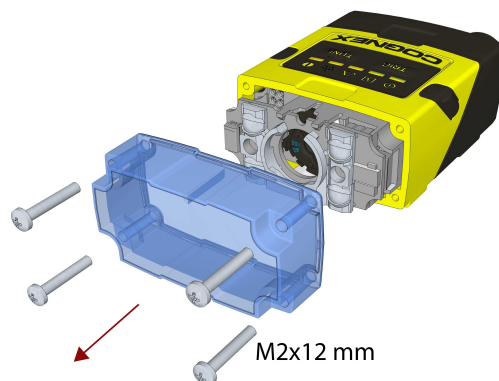

3. Insert the filter at the bottom side of the round opening in the transparent plastic part.

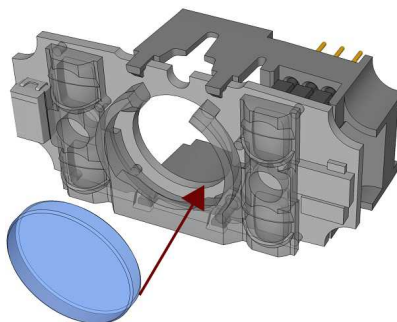

4. Push the top side of the filter firmly until it is sitting flat against the PCB.

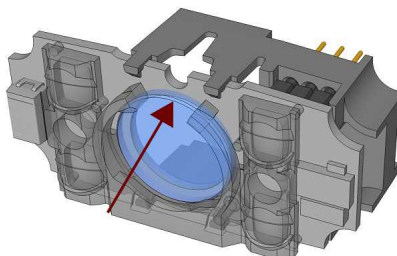

Note: Use your finger to push the filter in and then a cotton bud to clean the filter, or use a cotton bud to push the filter into place.

- Attach the cover. Observing the tightening sequence below, tighten all four screws to 9 Ncm (0.80 in-lb) using a torque wrench.

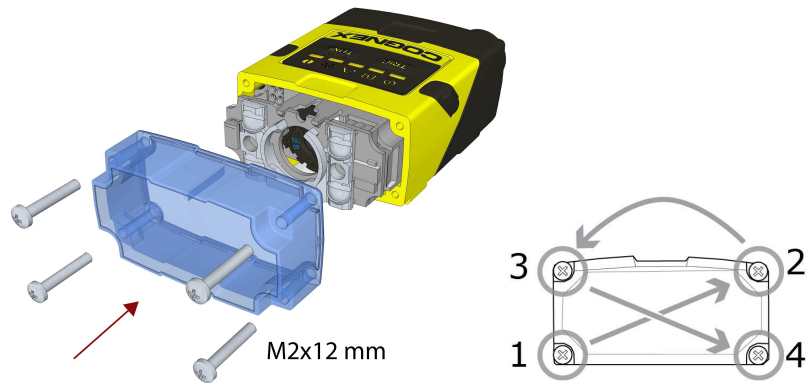

Note: The rib in the front cover must be oriented to the top side.

- Restore power to the 24VDC power supply and turn it on if necessary.

Working Distance and Field of View

The working distance is the distance from the vision sensor lens to the part; field of view is what the vision sensor can see at that distance. As the working distance increases, so does the field of view.

In each working distance and field of view chart, the x-axis represents the working distance and the y-axis represents the horizontal field of view. The following table shows the working distance and field of view examples for the In-Sight 2000 vision sensors with the S-Mount/M12 lens configuration (default 640 x 480 image resolution).

Working Distance	Field of View Width (mm)					
	3.6 mm	6 mm	8 mm	12 mm	16 mm	25 mm
50	100	55	N/A	N/A	N/A	N/A
100	166.7	100	69.6	41	25.8	N/A
200	300	190	135	85	55	34
400	465	362	254.3	157.9	111.9	70.1
500	569.3	449.7	316.2	197.2	140.6	88.7

In-Sight 2000 Vision Sensor (S-Mount/M12 Lens Configuration)

The following chart shows the horizontal field of view for In-Sight 2000 vision sensors with 640 x 480 image resolution (default).

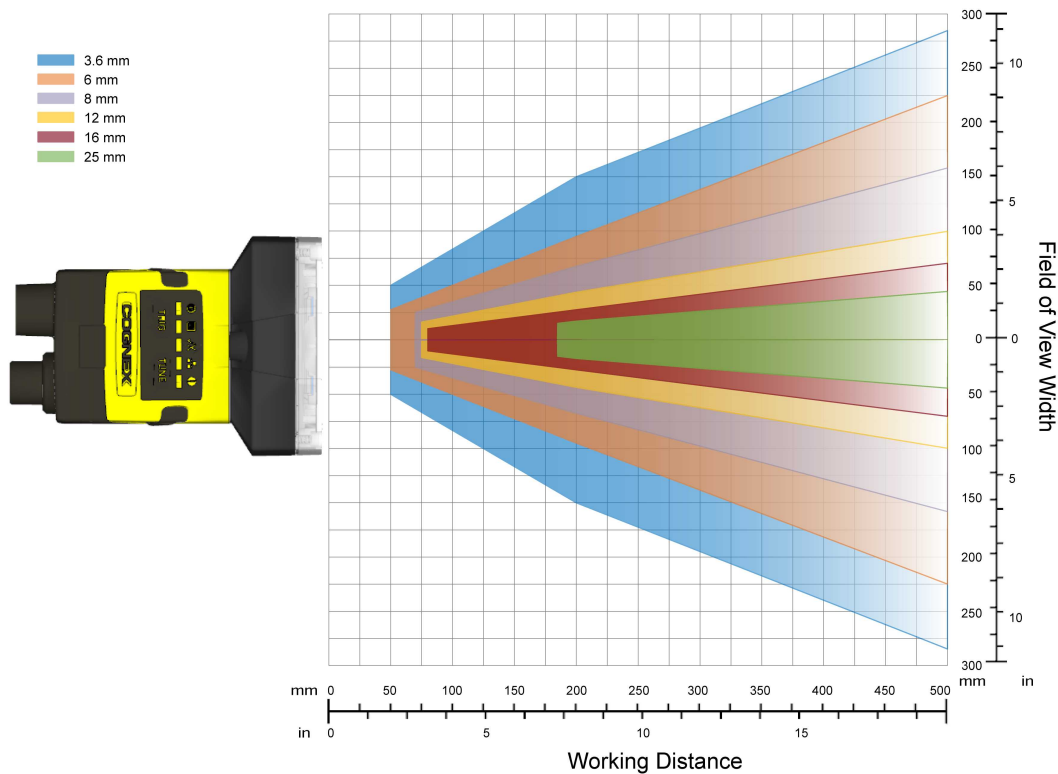

The following chart shows the horizontal field of view for In-Sight 2000 vision sensors with 640 x 480 image resolution (2X Image Magnification mode).

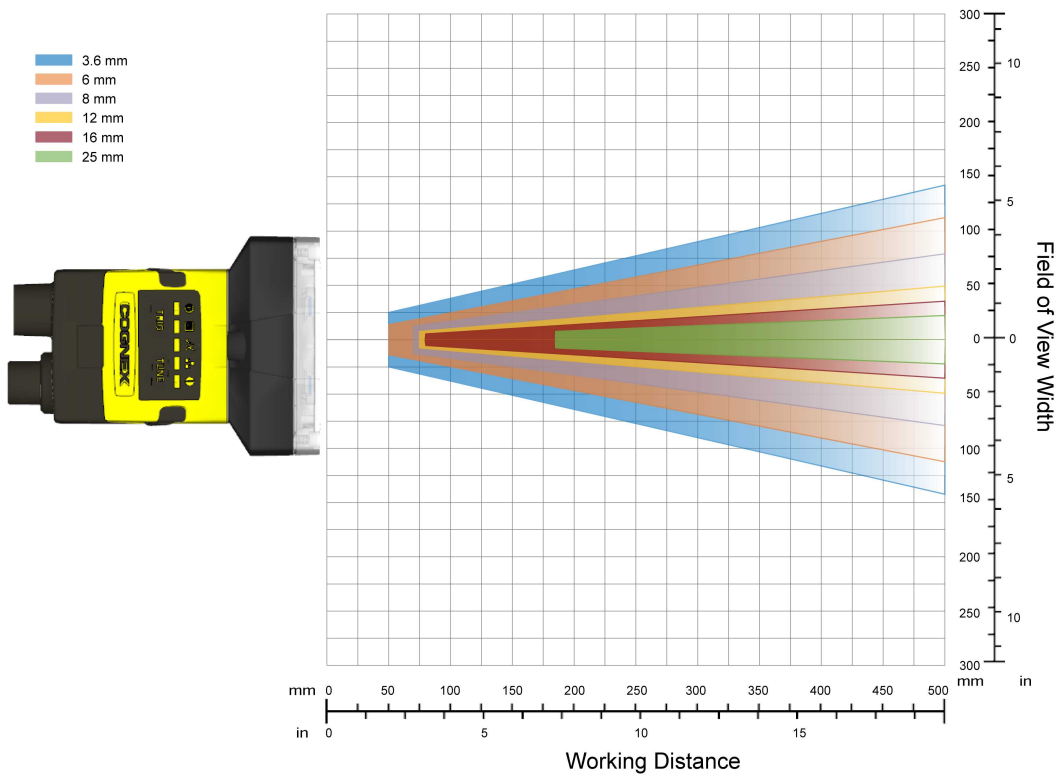

The following chart shows the horizontal field of view for In-Sight 2000 vision sensors with 800 x 600 image resolution (2X Image Magnification mode).

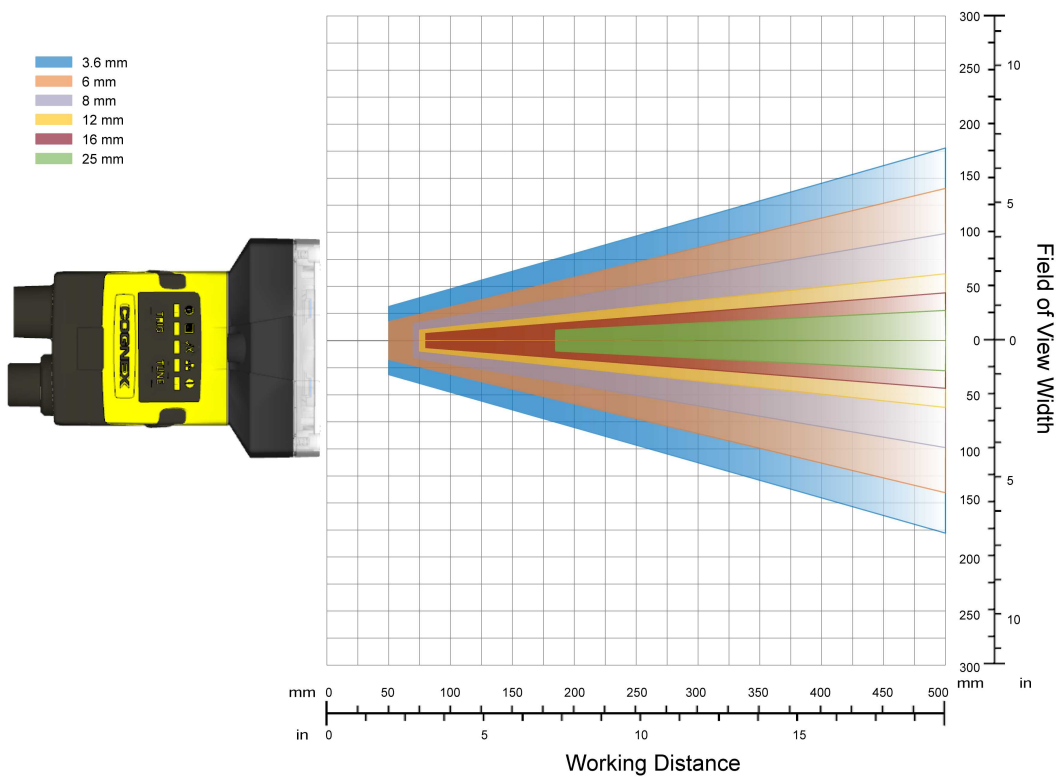

In-Sight 2000 Vision Sensor (Liquid Lens Configuration)

The following chart shows the horizontal field of view for In-Sight 2000 vision sensors with 640 x 480 image resolution (default).

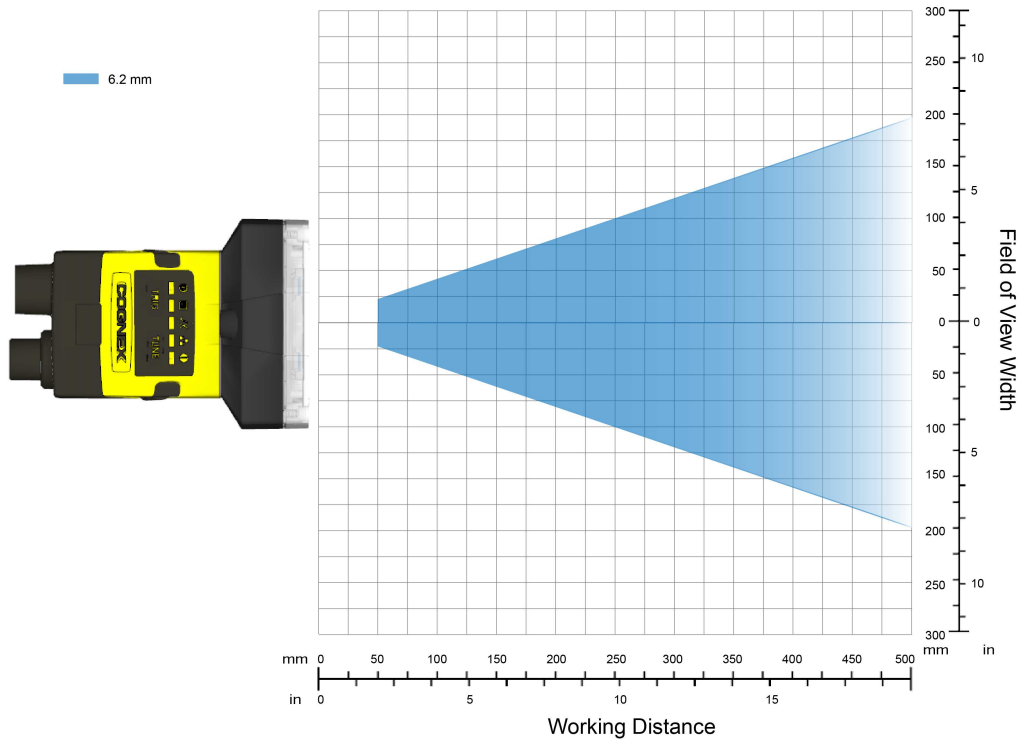

The following chart shows the horizontal field of view for In-Sight 2000 vision sensors with 640 x 480 image resolution (2X Image Magnification mode).

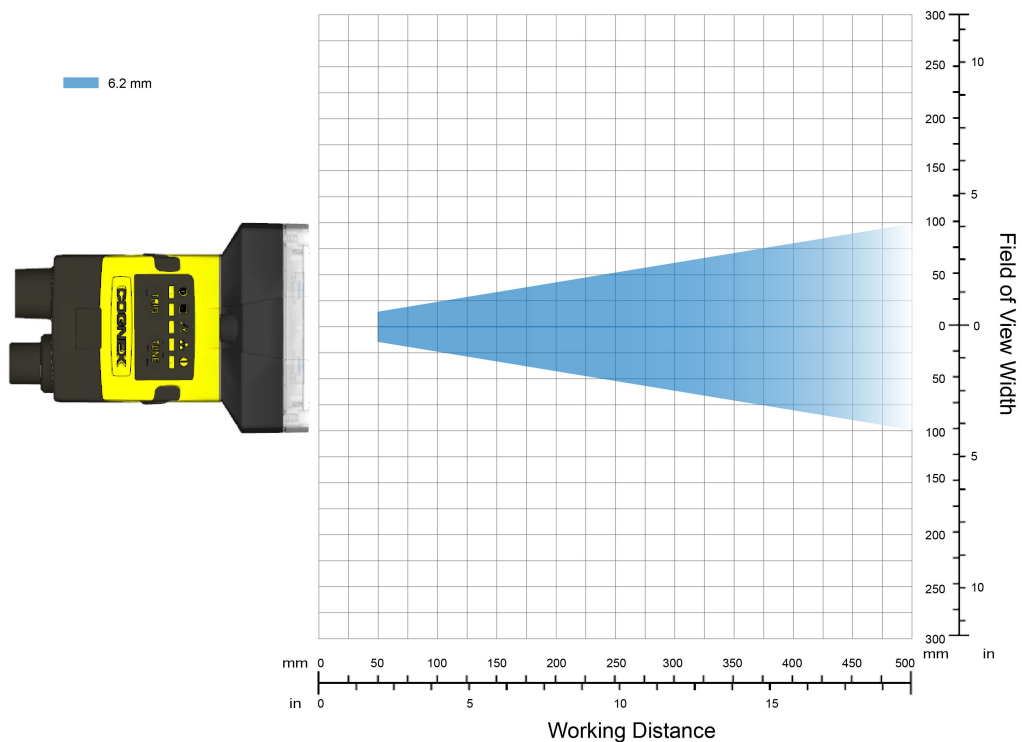

The following chart shows the horizontal field of view for In-Sight 2000 vision sensors with 800 x 600 image resolution (2X Image Magnification mode).

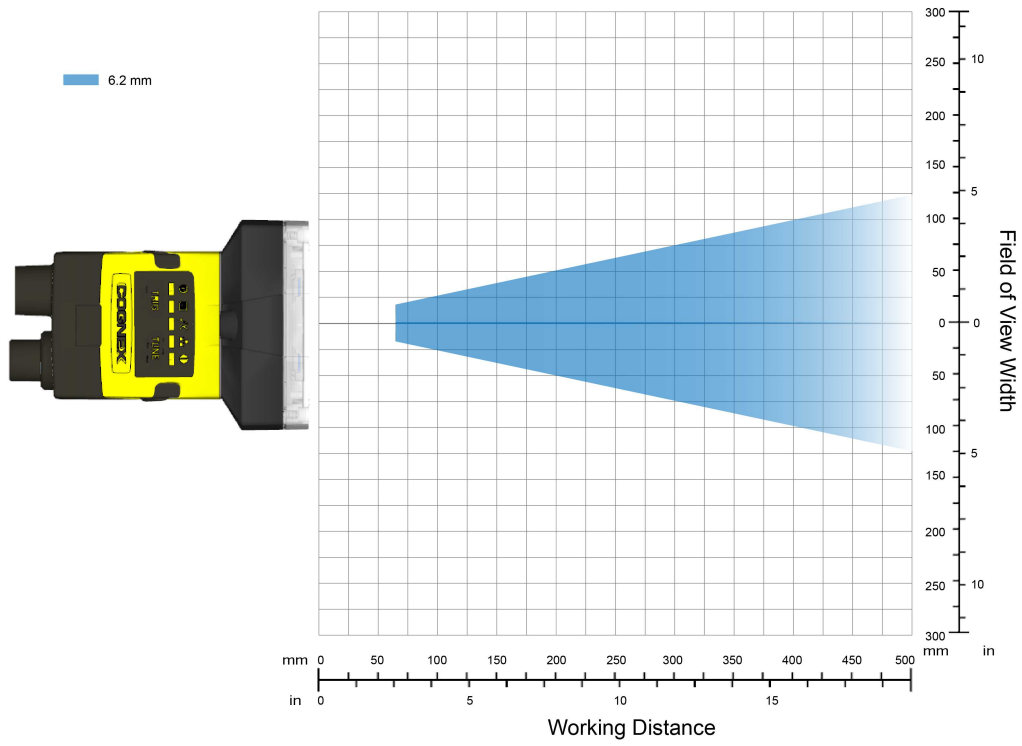

In-Sight 2000 Mini Vision Sensor

The following chart shows the horizontal field of view for In-Sight 2000 Mini vision sensors with 640 x 480 image resolution (default).

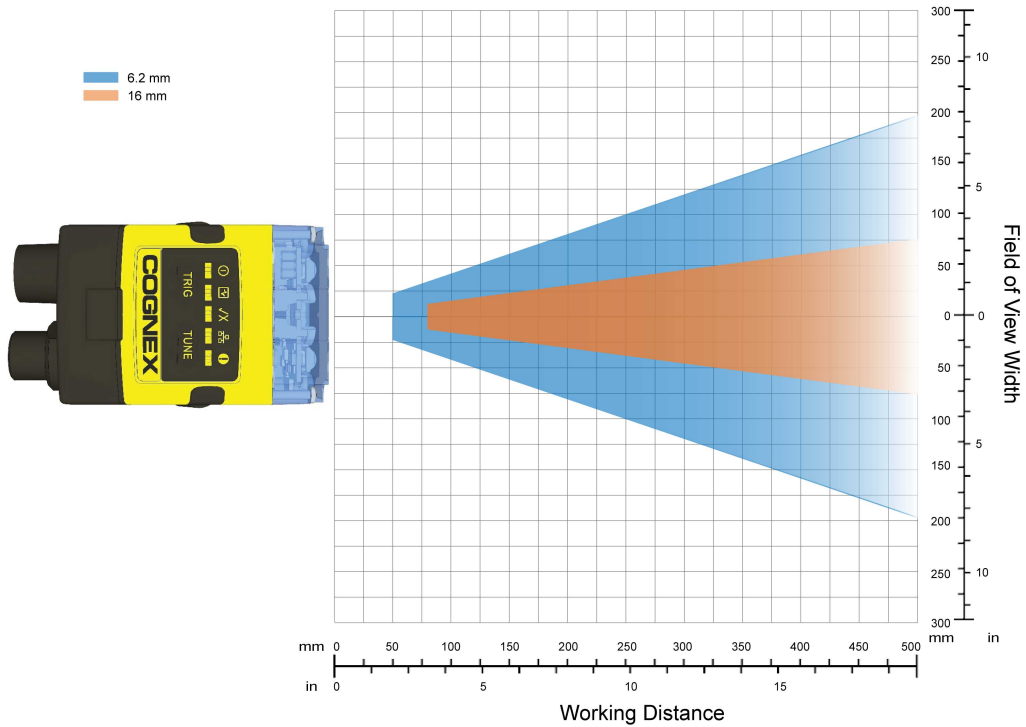

The following chart shows the horizontal field of view for In-Sight 2000 Mini vision sensors with 640 x 480 image resolution (2X Image Magnification mode).

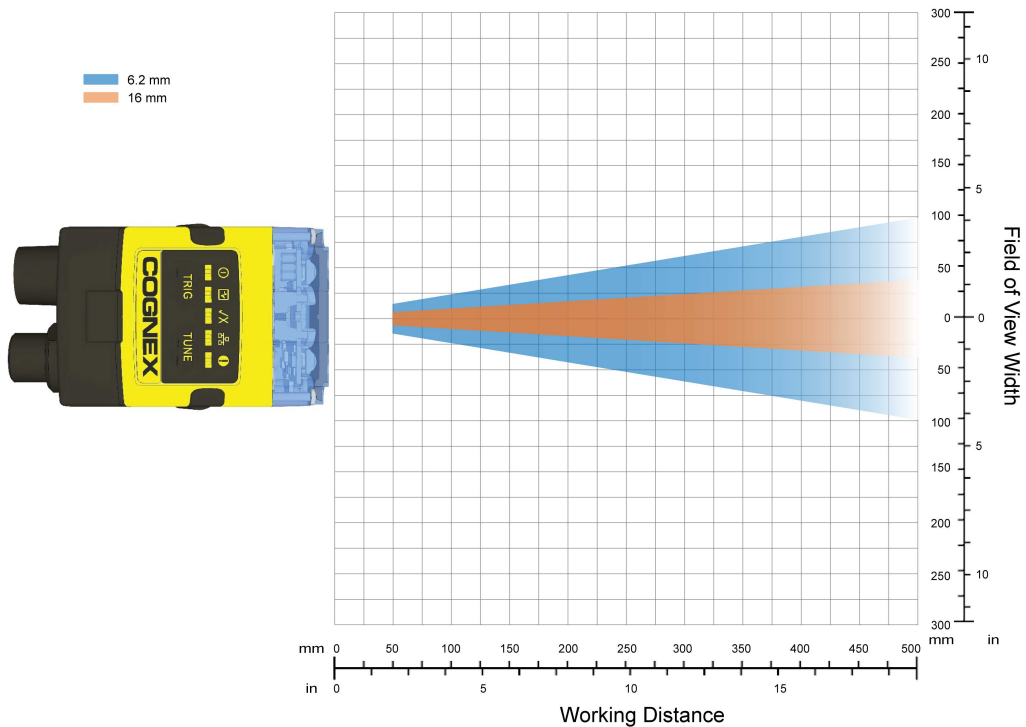

The following chart shows the horizontal field of view for In-Sight 2000 Mini vision sensors with 800 x 600 image resolution (2X Image Magnification mode).

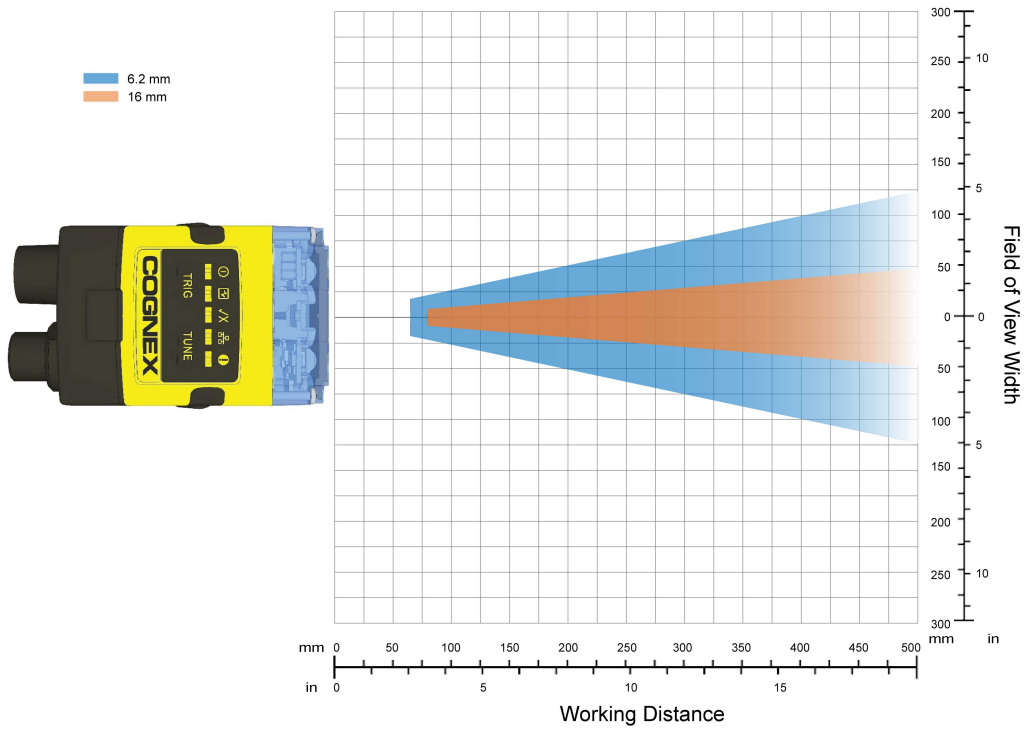

Connect the Ethernet Cable

1. Connect the Ethernet cable M12 connector to the vision sensor Ethernet connector.

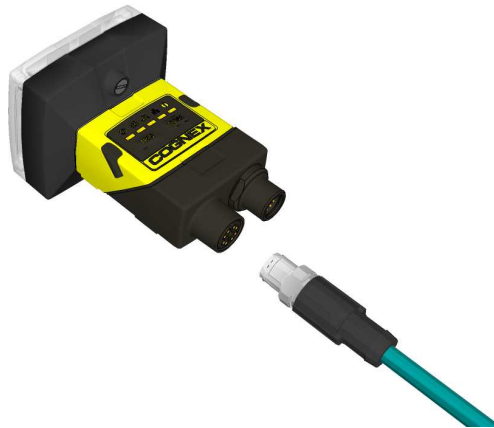

2. Connect the Ethernet cable RJ-45 connector to a switch/router or PC, as applicable.

Connect the Breakout Cable

Note: You can clip unused wires short or use a tie made of non-conductive material to tie them back. Keep bare wires separated from the +24VDC wire.

1. Verify that the 24VDC power supply is unplugged and not receiving power.
2. Optionally, connect the I/O or serial wires to an appropriate device (for example, a PLC or a serial device). For more information, refer to [Breakout Cable Specifications on page 50](#).
3. Attach the Breakout cable +24VDC (red wire) and GROUND (black wire) to the corresponding terminals on the power supply.

CAUTION: Never connect voltages other than 24VDC. Always observe the polarity shown.

4. Attach the Breakout cable M12 connector to vision sensor Power, I/O and RS-232 connector.

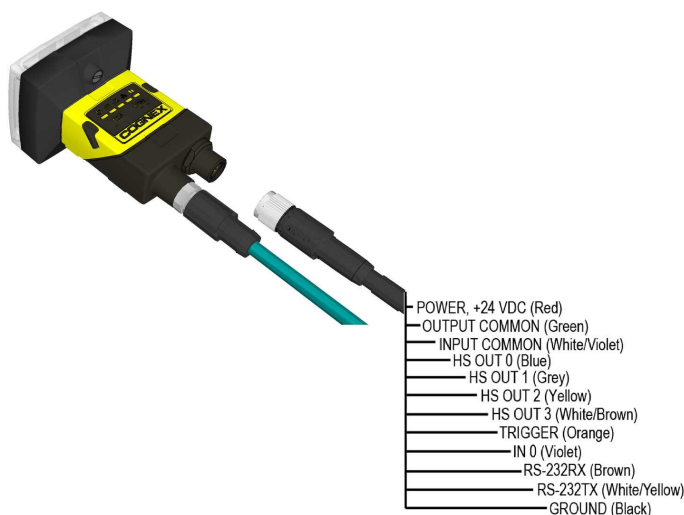

5. Restore power to the 24VDC power supply and turn it on if necessary.

Connect the CIO-1400 I/O Expansion Module (Optional)

Note: When connected to the CIO-1400 I/O expansion module, the two high-speed outputs are configured as NPN (current sinking) with 50mA maximum current and the general-purpose outputs are configurable as NPN (current sinking) or PNP (current sourcing) with 100mA maximum current.

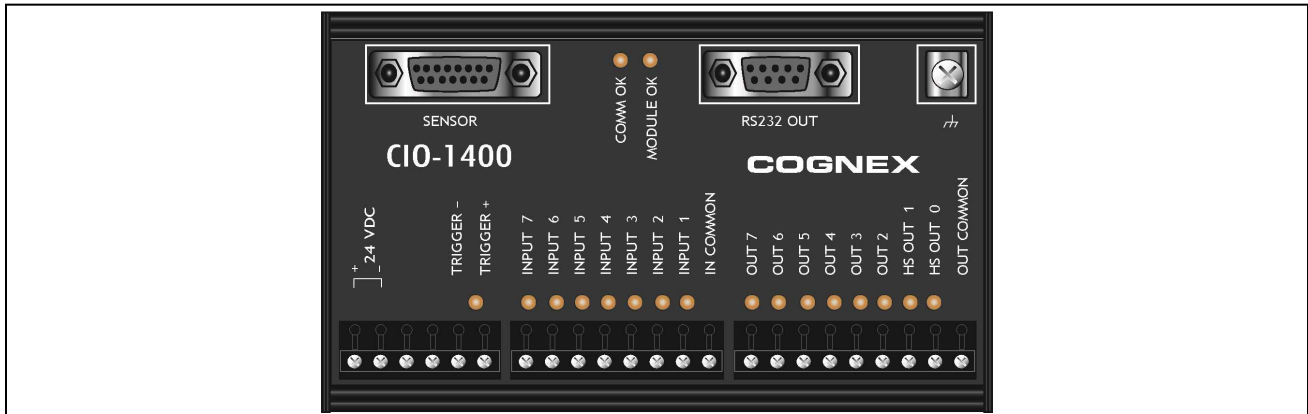

Connector/Indicator	Description
COMM OK LED (yellow)	Illuminates to indicate that the vision sensor and I/O module are communicating properly.
MODULE OK LED (yellow)	Illuminates after the I/O module has initialized and is ready to communicate with the vision sensor.
I/O and Trigger Status LEDs (yellow)	Illuminates to indicate when an input/output has switched ON.
SENSOR Port	Connect an I/O Module cable, which provides power, trigger, I/O and RS-232 signals to the vision sensor.
RS232 OUT Port	Connect an RS-232 serial cable, which provides RS-232 communications between the I/O module and an external serial device.
Frame Ground Terminal \oplus	Connect a common frame ground.

1. Connect the I/O module's power wires.

Note: Never connect the I/O module to a power source other than 24VDC. Any other voltage creates a risk of fire or shock and can damage the hardware. Do not connect the 24VDC power source to any terminals other than the 24VDC + and – power terminals.

- a. Verify that the 24VDC power supply is unplugged and not receiving power.
- b. Use a screwdriver to loosen the I/O module's power terminals (labeled 24VDC + and –).
- c. Insert the 24VDC + and – wires (16 - 26 AWG, solid or stranded wire) from the power supply into the 24VDC + and – terminals on the I/O module.
- d. Tighten the screw terminals with the screwdriver to secure the wire leads in the terminal block; the maximum torque is 0.4 Nm (3.5 in-lb).

2. Connect a frame ground wire to the I/O module's Frame Ground terminal. Connect the other end of the frame ground wire to frame ground.

CAUTION: The shield ground connections of the RS232 OUT port, SENSOR port, and Frame Ground terminal are internally connected. The system grounding is designed to be at a zero ground potential; this zero ground potential extends through the cable and to peripheral equipment (e.g., a vision sensor, PLC, etc.). To ensure safe operating conditions, it is strongly recommended that all ground connections are checked to ensure that a zero ground potential is met.

3. Connect the I/O module's I/O wires.
 - a. Determine how I/O devices will be connected to the I/O module's input and output terminals.
 - b. To loosen the appropriate screw terminals, use a screwdriver.
 - c. Connect the input and output wires to the input and output terminals.
 - d. Connect the other end of the input and output wires to the corresponding I/O device.
 - e. Tighten the screw terminals with the screwdriver to secure the wire leads in the terminal block; the maximum torque is 0.4 Nm (3.5 in-lb).
4. To connect the vision sensor to a serial device, plug an RS-232 serial cable (DB9 male connector) into the I/O module's RS232 OUT port and connect the other end of the cable to the serial device. Tighten the connector screws to secure it to the I/O module.
5. Connect the I/O Module cable (CCB-PWRIO-MOD-xx) to the vision sensor.
 - a. Connect the I/O Module cable's M12 connector to the vision sensor's Power, I/O and RS-232 connector.
 - b. Connect the I/O Module cable's DB15 connector to the I/O module's SENSOR port.
 - c. Restore power to the I/O module's 24VDC power supply and turn it on if necessary.

Specifications

In-Sight 2000 Vision Sensor Specifications

Specifications	2000-110	2000-120	2000-120C	2000-130	2000-130C	2000-23M
Minimum Firmware Version	In-Sight 5.2.1	In-Sight 5.2.1	In-Sight 5.3.0	In-Sight 5.2.1	In-Sight 5.3.0	In-Sight 5.5.0
	In-Sight 5.5.0 (liquid lens configuration with auto-focus capability)					
Memory	Job/Program: 32MB non-volatile flash memory; unlimited storage via remote network device Image Processing: 128MB SDRAM					
Imager	1/3-inch CMOS, 4.80 mm x 3.60 mm (W x H), 3.75 μ m sq. pixels					
Lens	S-Mount/M12, standard 8 mm, optional 3.6 mm, 6 mm, 12 mm, 16 mm, 25 mm					
	6.2 mm liquid lens with auto-focus					
Image Resolution (pixels) ¹	640 x 480	640 x 480 (default)		640 x 480 (default)		640 x 480
		640 x 480 (2x image magnification mode)		640 x 480 (2x image magnification mode)		640 x 480 (2x image magnification mode)
			800 x 600 (2x image magnification mode)		800 x 600 (2x image magnification mode) (default)	
Bit Depth	256 grey levels (8 bits/pixel)		24-bit color	256 grey levels (8 bits/pixel)	24-bit color	256 grey levels (8 bits/pixel)
Electronic Shutter Speed	0 to 1000 ms					
Frames Per Second (FPS) ²	40 FPS	75 FPS	55 FPS	75 FPS	55 FPS	75 FPS
Trigger	1 opto-isolated, acquisition trigger input. Remote software commands via Ethernet.					
	Voltage: ON 15 to 24VDC (24VDC nominal); OFF 0 to 5VDC (0VDC nominal)					
	Current: 3.6 mA @ 12VDC, 7.5 mA @ 24VDC, Resistance: ~5.48 kOhms					
Discrete Inputs	1 opto-isolated general-purpose input line. (7 general-purpose inputs available when using the optional CIO-1400 I/O expansion module ³ .)					
	Voltage: ON 15 to 24VDC (24VDC nominal); OFF 0 to 5VDC (0VDC nominal)					
	Current: 3.6 mA @ 12VDC, 7.5 mA @ 24VDC, Resistance: ~5.48 kOhms					
Discrete Outputs	4 opto-isolated high-speed output lines. (2 high-speed outputs, plus 6 general-purpose outputs available when using the optional CIO-1400 expansion I/O module.)					
	Voltage: 28VDC maximum through external load					
	Current ⁴ : 50 mA maximum ON sink or source, OFF state leakage current 100 μ A External load resistance 240 Ohms to 10K Ohms Each line rated at a maximum 50 mA, protected against over-current, short circuits and transients from switching inductive loads. High current inductive loads require external protection diode.					

¹ The vision sensor's resolution can be configured in the In-Sight Explorer software. Refer to the Image Settings Dialog in the *In-Sight® Explorer Help* file for more information.

² Maximum frame rate with minimum exposure; no vision tools; and 640 x 480 image with 2x Image Magnification enabled (for 2000-120/130 models)

³ The CIO-1400 I/O expansion module supports In-Sight 2000 series vision sensors with firmware version 5.3.0 and higher.

⁴ When connected to the CIO-1400 I/O expansion module, the two high-speed outputs are configured as NPN (current sinking) with 50mA maximum current and the general-purpose outputs are configurable as NPN (current sinking) or PNP (current sourcing) with 100mA maximum current.

Specifications	2000-110	2000-120	2000-120C	2000-130	2000-130C	2000-23M
Power Consumption	24VDC ±10%, 48W (2.0A) maximum when illumination is on					
Status LEDs	Power, Trigger Status, Pass/Fail Status, Network and Error					
Network Communication	EtherNet/IP, PROFINET, SLMP, SLMP Scanner, Modbus TCP, TCP/IP, UDP, FTP, Telnet (Native Mode). Supports DHCP (factory default), static and link-local IP address configuration					
RS-232	RxD, TxD according to TIA/EIA-232-F					
Material	Painted aluminum					
Mounting	Four M3 threaded mounting holes					
Weight	200 g (7.05 oz.)					
Temperature	Operating: 0°C to 40°C (32°F to 104°F) Storage: -10°C to 60°C (14°F to 140°F)					
Maximum Humidity	< 95%, non-condensing					
Protection	IP65 when all connectors are attached to cables or shielded by a sealing cap					
Shock (Shipping and Storage)	IEC 60068-2-27: 1000 shocks, semi-sinusoidal, 11g, 10ms					
Vibration (Shipping and Storage)	IEC 60068-2-6: vibration test in each of the three main axis for 2 hours @ 10 Gs (10 to 500 Hz at 100m/s ² /15mm)					

In-Sight 2000 Mini Vision Sensor Specifications

Specifications	2000-110 Mini	2000-120 Mini	2000-120C Mini	2000-130 Mini	2000-130C Mini	2000-23M Mini
Minimum Firmware Version	In-Sight 5.5.0					
Memory	Job/Program: 32MB non-volatile flash memory; unlimited storage via remote network device Image Processing: 128MB SDRAM					
Imager	1/3-inch CMOS, 4.8 mm x 3.6 mm (W x H), 3.75 μ m sq. pixels					
Lens	6.2 mm liquid lens with auto-focus, 16 mm liquid lens with auto-focus					
Image Resolution (pixels) ¹	640 x 480	640 x 480 (default)		640 x 480 (default)		640 x 480
		640 x 480 (2x image magnification mode)		640 x 480 (2x image magnification mode)		640 x 480 (2x image magnification mode)
				800 x 600 (2x image magnification mode)		800 x 600 (2x image magnification mode) (default)
Bit Depth	256 grey levels (8 bits/pixel)		24-bit color	256 grey levels (8 bits/pixel)	24-bit color	256 grey levels (8 bits/pixel)
Electronic Shutter Speed	0 to 1000 ms					
Frames Per Second (FPS) ²	40 FPS	75 FPS	55 FPS	75 FPS	55 FPS	75 FPS
Trigger	1 opto-isolated, acquisition trigger input. Remote software commands via Ethernet.					
	Voltage: ON 15 to 24VDC (24VDC nominal); OFF 0 to 5VDC (0VDC nominal)					
	Current: 3.6 mA @ 12VDC, 7.5 mA @ 24VDC, Resistance: ~5.48 kOhms					
Discrete Inputs	1 opto-isolated general-purpose input line. (7 general-purpose inputs available when using the optional CIO-1400 I/O expansion module ³ .)					
	Voltage: ON 15 to 24VDC (24VDC nominal); OFF 0 to 5VDC (0VDC nominal)					
	Current: 3.6 mA @ 12VDC, 7.5 mA @ 24VDC, Resistance: ~5.48 kOhms					
Discrete Outputs	4 opto-isolated high-speed output lines. (2 high-speed outputs, plus 6 general-purpose outputs available when using the optional CIO-1400 expansion I/O module.)					
	Voltage: 28VDC maximum through external load					
	Current ⁴ : 50 mA maximum ON sink or source, OFF state leakage current 100 μ A External load resistance 240 Ohms to 10K Ohms Each line rated at a maximum 50 mA, protected against over-current, short circuits and transients from switching inductive loads. High current inductive loads require external protection diode.					
Power Consumption	24VDC \pm 10%, 48W (1.0A maximum, 5W average)					
Status LEDs	Power, Trigger Status, Pass/Fail Status, Network and Error					

¹ The vision sensor's resolution can be configured in the In-Sight Explorer software. Refer to the Image Settings Dialog in the *In-Sight® Explorer Help* file for more information.

² Maximum frame rate with minimum exposure; no vision tools; and 640 x 480 image with 2x Image Magnification enabled (for 2000-120 mini/130 mini models)

³ The CIO-1400 I/O expansion module supports In-Sight 2000 series vision sensors with firmware version 5.3.0 and higher.

⁴ When connected to the CIO-1400 I/O expansion module, the two high-speed outputs are configured as NPN (current sinking) with 50mA maximum current and the general-purpose outputs are configurable as NPN (current sinking) or PNP (current sourcing) with 100mA maximum current.

Specifications	2000-110 Mini	2000-120 Mini	2000-120C Mini	2000-130 Mini	2000-130C Mini	2000-23M Mini
Network Communication	EtherNet/IP, PROFINET, SLMP, SLMP Scanner, Modbus TCP, TCP/IP, UDP, FTP, Telnet (Native Mode). Supports DHCP (factory default), static and link-local IP address configuration					
RS-232	RxD, TxD according to TIA/EIA-232-F					
Material	Painted aluminum					
Mounting	Four M3 threaded mounting holes					
Weight	142 g (5.01 oz.)					
Temperature	Operating: 0°C to 40°C (32°F to 104°F) Storage: -10°C to 60°C (14°F to 140°F)					
Maximum Humidity	< 95%, non-condensing					
Protection	IP65 when all connectors are attached to cables or shielded by a sealing cap					
Shock (Shipping and Storage)	IEC 60068-2-27: 1000 shocks, semi-sinusoidal, 11g, 10ms					
Vibration (Shipping and Storage)	IEC 60068-2-6: vibration test in each of the three main axis for 2 hours @ 10 Gs (10 to 500 Hz at 100m/s ² /15mm)					

Acquisition Trigger

The vision sensor features one acquisition trigger input that is opto-isolated. The acquisition trigger input can be configured to trigger from either an NPN (current sinking) or PNP (current sourcing) device.

Specification	Description
Voltage	ON: 15 to 24VDC (24VDC nominal) OFF: 0 to 5VDC (0VDC nominal)
Current	3.6 mA @ 12VDC, 7.5 mA @ 24VDC Resistance: ~5.48 kOhms
Delay	1.45 ms maximum latency between leading edge of trigger and start of acquisition. Input pulse should be a minimum of 1 ms wide.

To trigger from an NPN (pull-down) type photo-detector or PLC output, connect TRIGGER to the output of the photoelectric sensor or PLC and connect INPUT COMMON to +24VDC. When the output turns on, it pulls TRIGGER down to 0VDC, turning the opto-coupler on. For more information, refer to [Breakout Cable Specifications on page 50](#).

To trigger from a PNP (pull-up) type photo-detector or PLC output, connect TRIGGER to the output of the photoelectric sensor or PLC and connect INPUT COMMON to 0VDC. When the output turns on, it pulls TRIGGER up to 24VDC, turning the opto-coupler on. For more information, refer to [Breakout Cable Specifications on page 50](#).

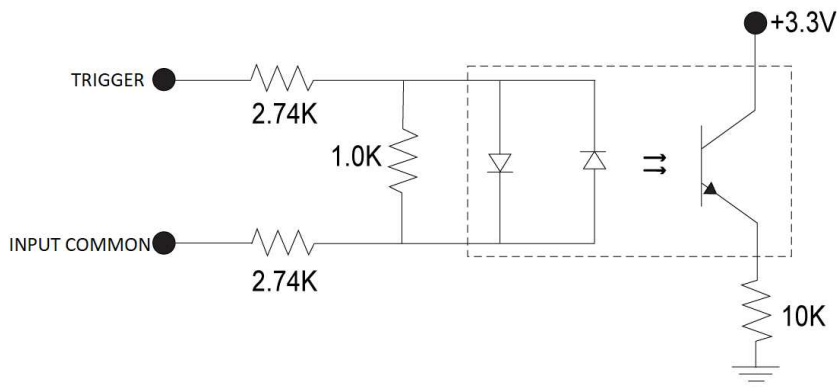

28V Max. across input pins - Transition approximately 12V (Min.)

General-Purpose Input

The vision sensor features one general-purpose input that is opto-isolated. The acquisition trigger input can be configured to trigger from either an NPN (current sinking) or PNP (current sourcing) device.

Specification	Description
Voltage	ON: 15 to 24VDC (24VDC nominal) OFF: 0 to 5VDC (0VDC nominal)
Current	3.6 mA @ 12VDC, 7.5 mA @ 24VDC Resistance: ~5.48 kOhms
Delay	1.45 ms maximum latency between leading edge of trigger and start of acquisition. Input pulse should be a minimum of 1 ms wide.

For NPN lines, connect IN 0 to the output of the photoelectric sensor or PLC and connect INPUT COMMON to +24VDC. When the output turns on, it pulls IN 0 down to 0VDC, turning the opto-coupler on. For more information, refer to [Breakout Cable Specifications on page 50](#).

For PNP lines, connect IN 0 to the output of the photoelectric sensor or PLC and connect INPUT COMMON to 0VDC. When the output turns on, it pulls IN 0 up to 24VDC, turning the opto-coupler on. For more information, refer to [Breakout Cable Specifications on page 50](#).

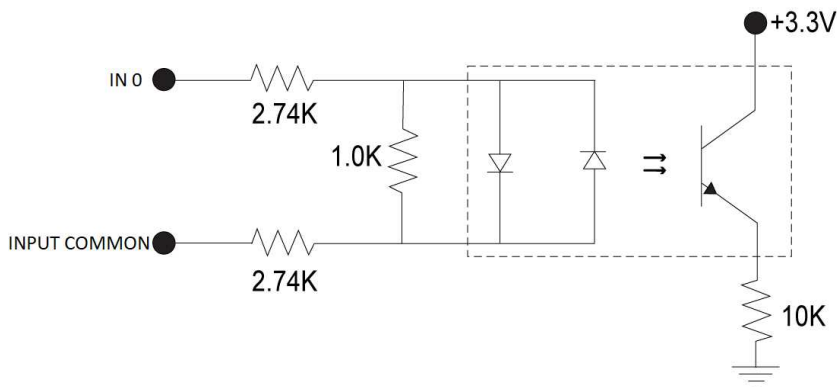

28V Max. across input pins - Transition approximately 12V (Min.)

High-Speed Outputs

The high-speed outputs can be used as either NPN (current sinking) or PNP (current sourcing) lines.

Specification	Description
Voltage	28VDC maximum through external load
Current ¹	50 mA maximum ON sink or source OFF state leakage current 100 μ A External load resistance 240 Ohms to 10K Ohms Each line rated at a maximum 50 mA, protected against over-current, short circuits and transients from switching inductive loads. High current inductive loads require external protection diode.

For NPN lines, the external load should be connected between the output and the positive supply voltage (<28VDC). The outputs pull down to less than 3VDC when ON, which causes current to flow through the load. When the outputs are OFF, no current flows through the load. For more information, refer to [Breakout Cable Specifications on page 50](#).

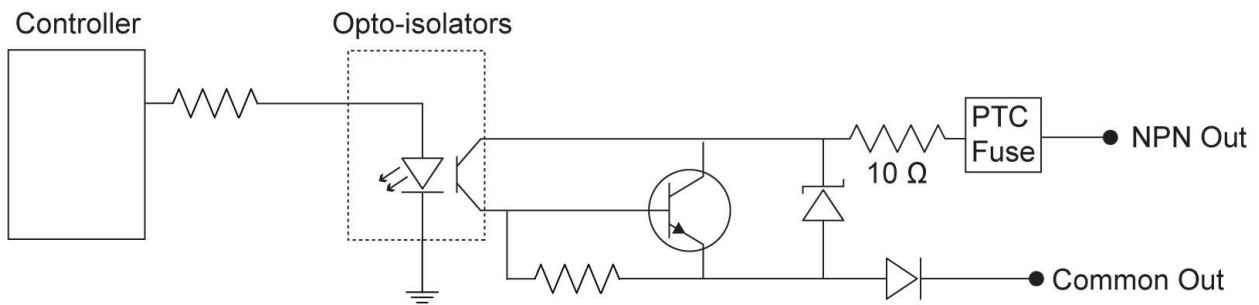

For PNP lines, the external load should be connected between the output and the negative supply voltage (0VDC). When connected to a 24VDC power supply, the outputs pull up greater than 21VDC when ON, and current flows through the load. When the outputs are OFF, no current flows through the load. For more information, refer to [Breakout Cable Specifications on page 50](#).

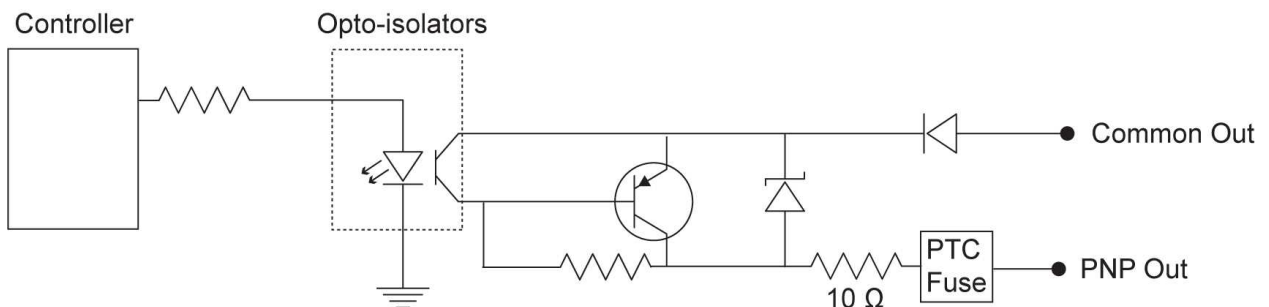

¹ When connected to the CIO-1400 I/O expansion module, the two high-speed outputs are configured as NPN (current sinking) with 50mA maximum current and the general-purpose outputs are configurable as NPN (current sinking) or PNP (current sourcing) with 100mA maximum current.

High-Speed Output Wiring

Note: For more information, refer to [Breakout Cable Specifications on page 50](#).

To connect to an NPN-compatible PLC input, connect Output 0, Output 1, Output 2 or Output 3 directly to the PLC input. When enabled, the output pulls the PLC input down to less than 3VDC.

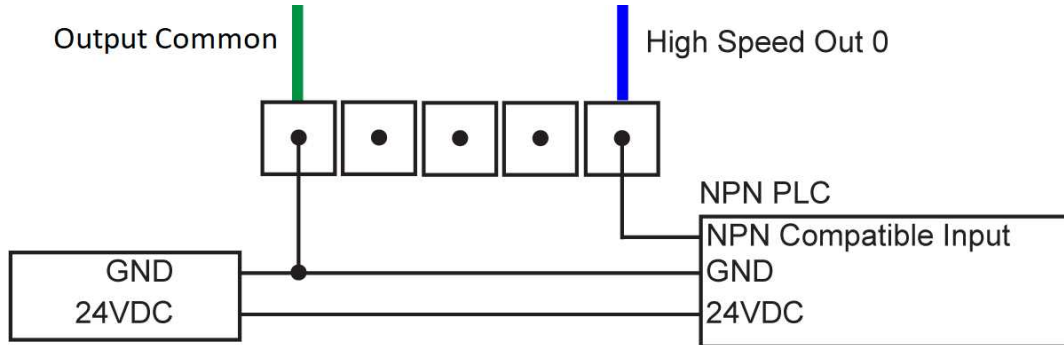

To connect to a PNP-compatible PLC input, connect Output 0, Output 1, Output 2 or Output 3 directly to the PLC input. When enabled, the output pulls the PLC input up to greater than 21VDC.

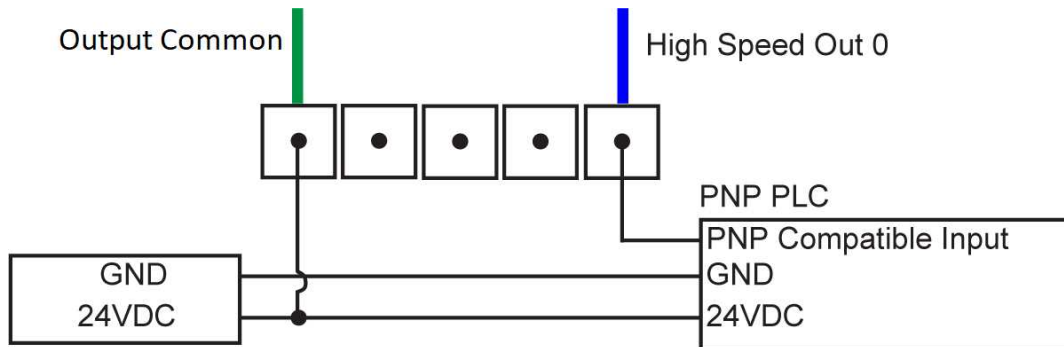

To connect the high-speed outputs to a relay, LED, or similar load, connect the negative side of the load to the output and the positive side to +24VDC. When the output switches to ON, the negative side of the load is pulled down to less than 3VDC, and 24VDC appears across the load. Use a protection diode for a large inductive load, with the anode connected to the output and the cathode connected to +24VDC.

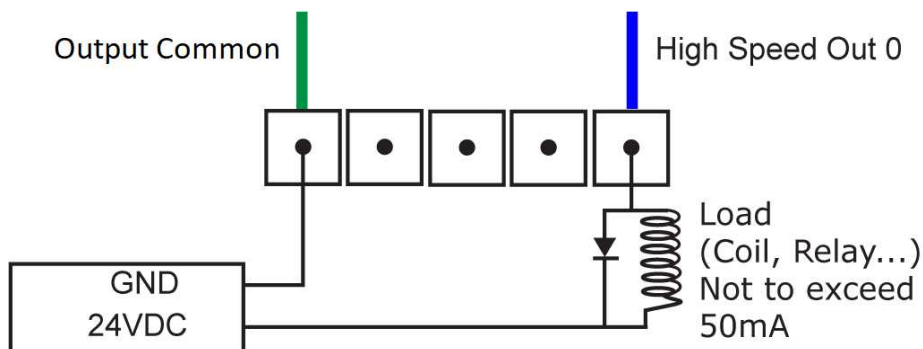

Breakout Cable Specifications

The Breakout cable provides connections to an external power supply, the acquisition trigger input, a general-purpose input, high-speed outputs, and RS-232 serial communications. The Breakout cable is not terminated.

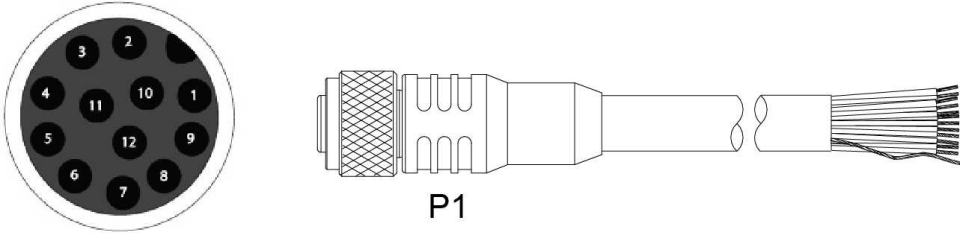

Pin#	Signal Name	Wire Color
1	HS OUT 2	Yellow
2	RS-232 Tx ¹	White/Yellow
3	RS-232 Rx ¹	Brown
4	HS OUT 3	White/Brown
5	IN 0	Violet
6	INPUT COMMON	White/Violet
7	+24VDC	Red
8	GND	Black
9	OUTPUT COMMON	Green
10	TRIGGER	Orange
11	HS OUT 0	Blue
12	HS OUT 1	Grey

Note:

- For RS-232, use the Power Supply return path for ground.



- Cables are sold separately.
- You can clip unused wires short or use a tie made of non-conductive material to tie them back. Keep bare wires separated from the +24VDC wire.

¹ If hardware handshaking is required, an I/O module must be used.

Ethernet Cable Specifications

The Ethernet cable provides Ethernet connection for network communications. The Ethernet cable can be connected to a single device or provide connections to multiple devices via a network switch or router.

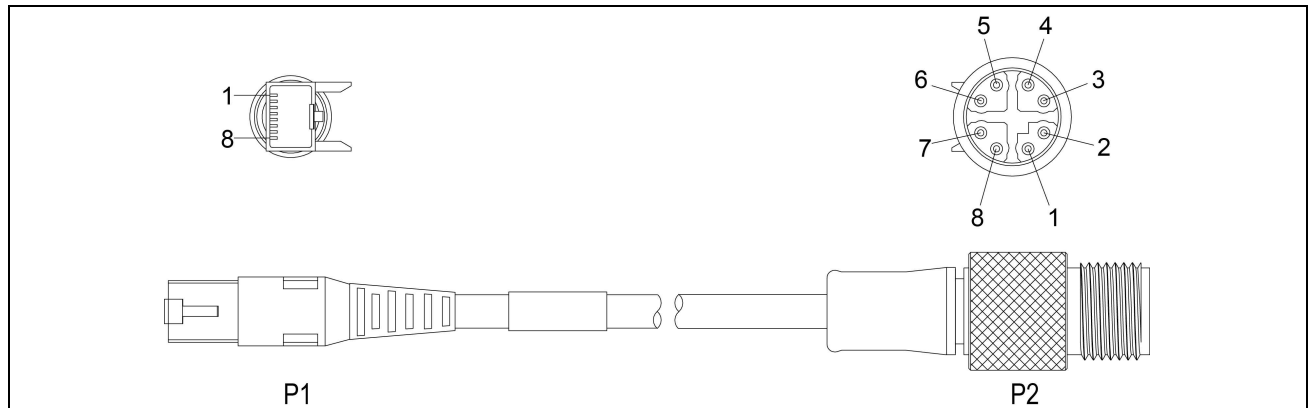

P1 Pin Number	Wire Color	Signal Name	P2 Pin Number
1	White/Orange	TxRx A +	1
2	Orange	TxRx A -	2
3	White/Green	TxRx B +	3
4	Blue	TxRx C +	8
5	White/Blue	TxRx C -	7
6	Green	TxRx B -	4
7	White/Brown	TxRx D +	5
8	Brown	TxRx D -	6

Note:



- Ensure that the cable bend radius begins at least six inches from the connector. Cable shielding can be degraded or cables can be damaged or wear out faster if a service loop or bend radius is tighter than 10X the cable diameter.
- Cables are sold separately. The wiring for this cable follows standard industrial Ethernet M12 specifications. It differs from the 568B standard.

I/O Module Cable Specifications

The I/O Module cable is used with the CIO-1400 I/O expansion module. The I/O Module cable connects the vision sensor directly to the I/O module via the DB15 connector. When the I/O module is used, all power and communication lines used by the vision sensor are connected using the I/O Module cable.

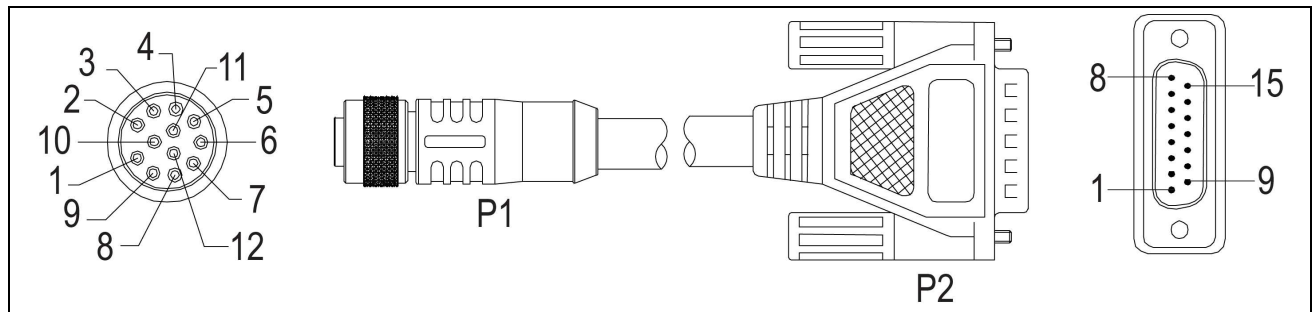

P1 Pin#	Signal Name	Wire Color	Signal Name	P2 Pin#
1	HS OUT 2	Yellow	Not Used	Not Used
2	RS-232 Tx	White/Yellow	RS-232 Rx	7
3	RS-232 Rx	Brown	RS-232 Tx	6
4	HS OUT 3	White/Brown	Not Used	Not Used
5	IN 0	Violet	Not Used	Not Used
6	INPUT COMMON	White/Violet	TRIGGER-	3
7	+24VDC	Red	+24VDC	1
8	GND	Black	-24VDC	8
9	OUTPUT COMMON	Green	-24VDC	8
10	TRIGGER	Orange	TRIGGER+	2
11	HS OUT 0	Blue	HS OUT 0	4
12	HS OUT 1	Grey	HS OUT 1	5

Note:



- Cables are sold separately.
- The CIO-1400 I/O expansion module supports In-Sight 2000 series vision sensors with firmware version 5.3.0 and higher.

In-Sight 2000 Vision Sensor Dimensions

Note:

- Dimensions are in millimeters [inches] and are for reference purposes only.
- All specifications are for reference purposes only and can change without notice.

Inline Configuration:

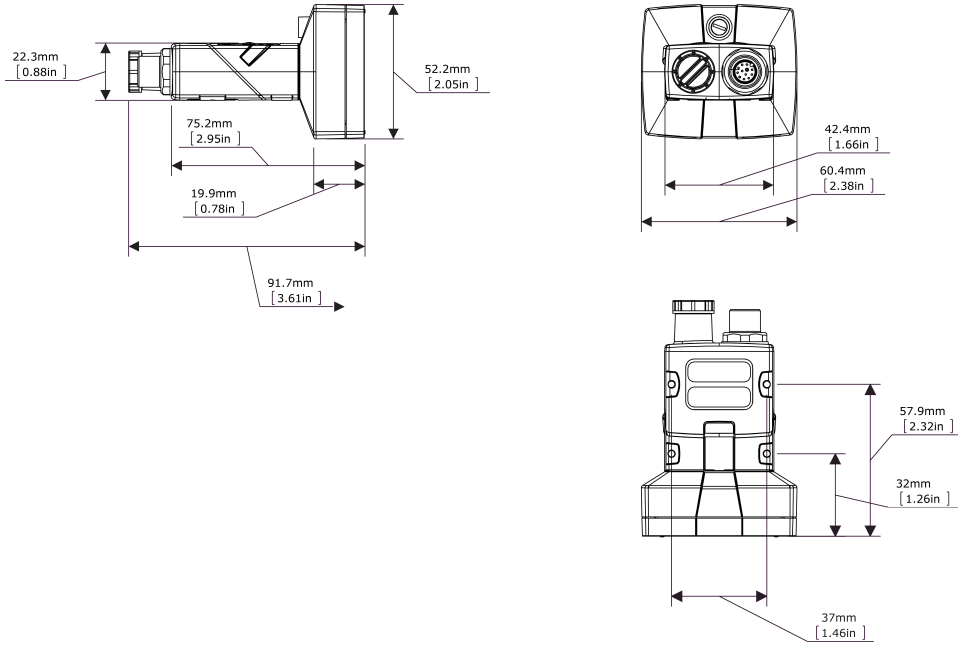

Right-angled Configuration:

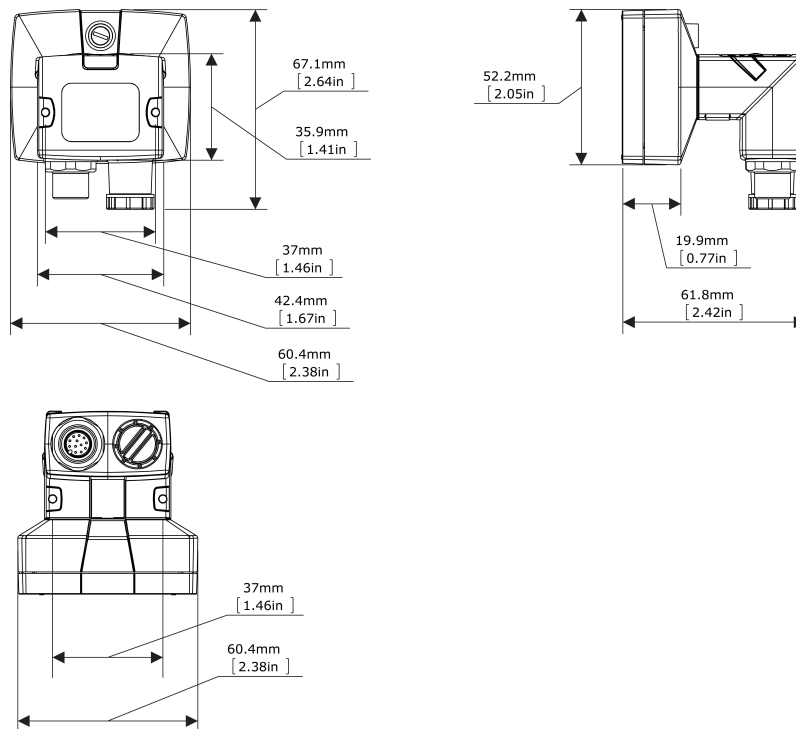

In-Sight 2000 Mini Vision Sensor Dimensions (With 6.2 mm Lens)

Note:



- Dimensions are in millimeters [inches] and are for reference purposes only.
- All specifications are for reference purposes only and can change without notice.

Inline Configuration:

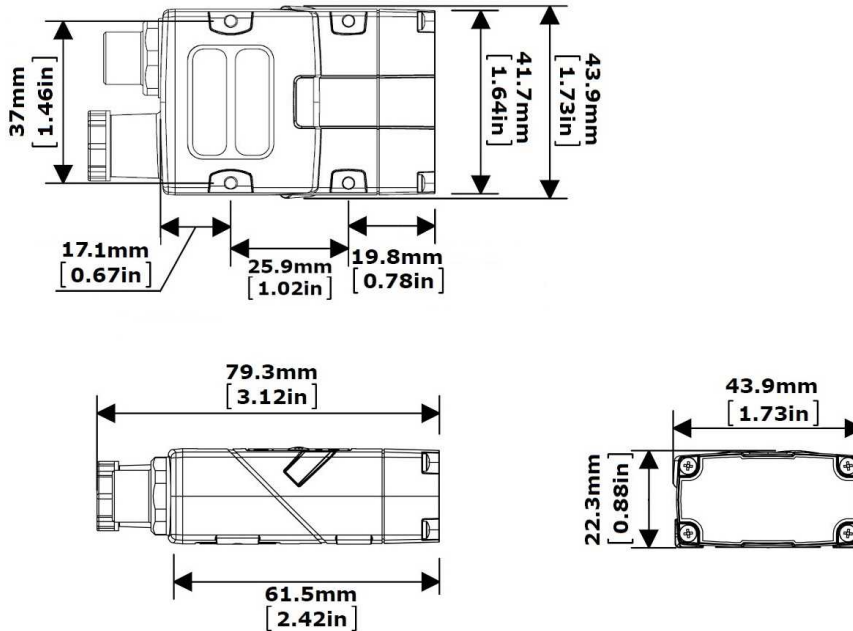

Right-angled Configuration:

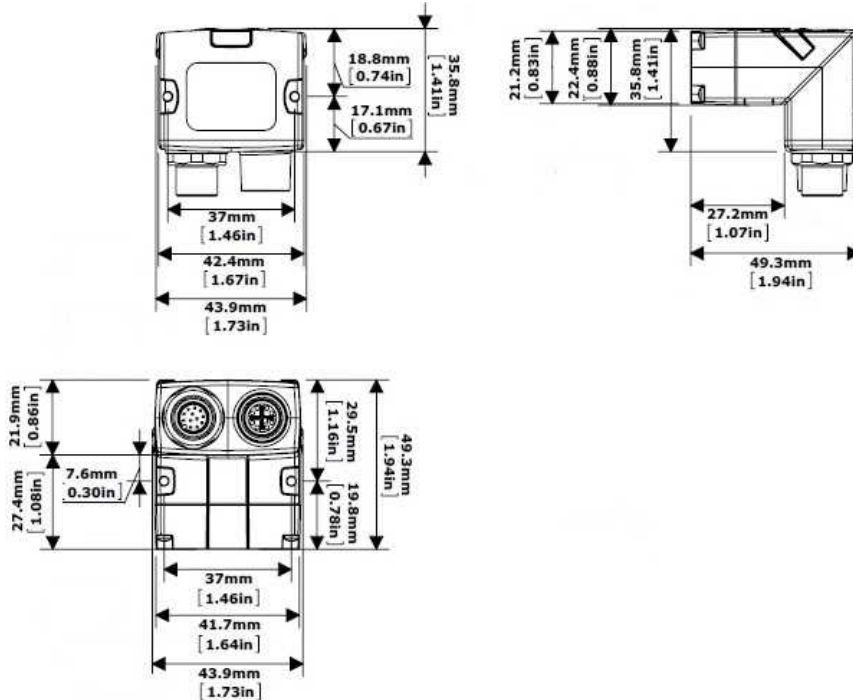

In-Sight 2000 Mini Vision Sensor Dimensions (With 16 mm Lens)

Note:



- Dimensions are in millimeters [inches] and are for reference purposes only.
- All specifications are for reference purposes only and can change without notice.

Inline Configuration:

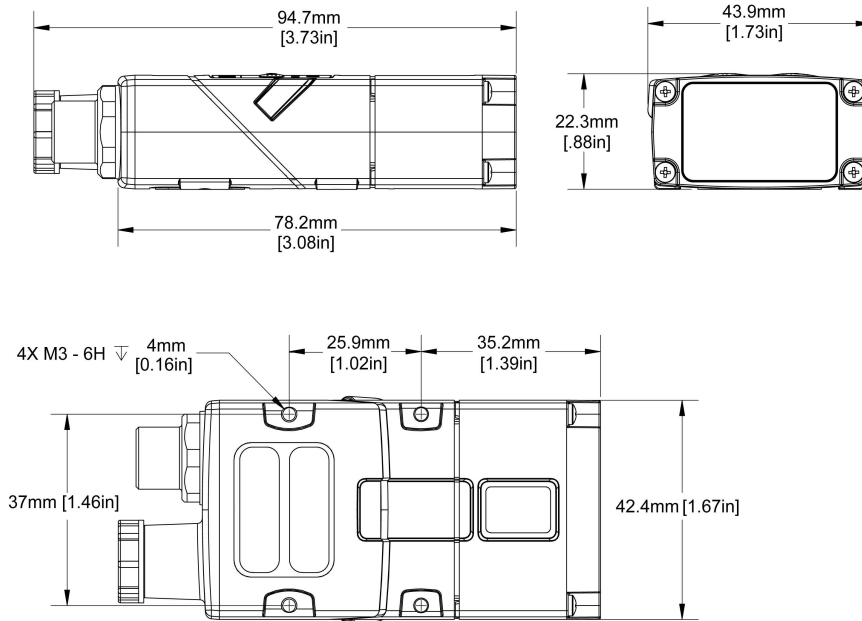

Right-angled Configuration:

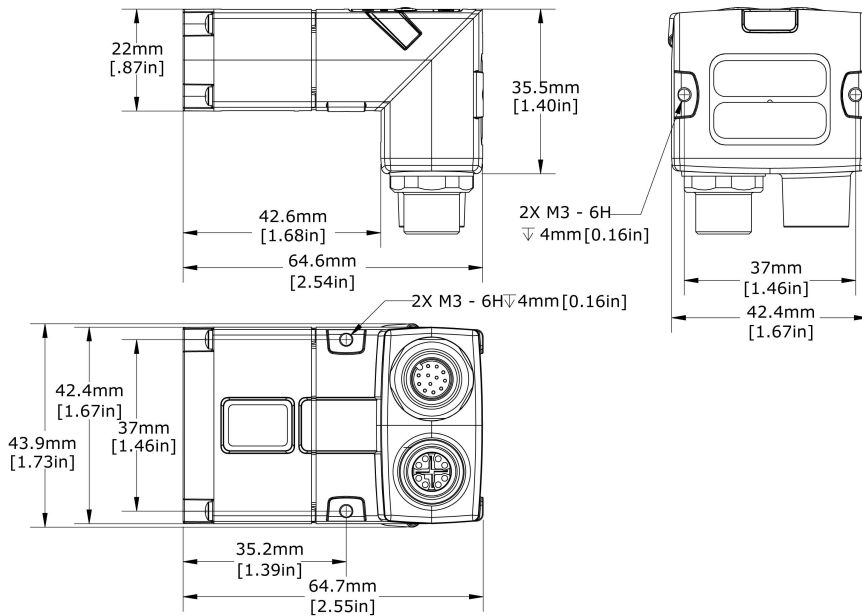

Cleaning/Maintenance

Clean the Vision Sensor Housing

To clean the outside of the vision sensor housing, use a small amount of mild detergent cleaner or isopropyl alcohol on a cleaning cloth. Do not pour the cleaner on the vision sensor housing.

 **CAUTION:** Do not attempt to clean any In-Sight product with harsh or corrosive solvents, including lye, methyl ethyl ketone (MEK) or gasoline.

Clean the Vision Sensor Image Sensor Window

To remove dust from the outside of the image sensor window, use a pressurized air duster. The air must be free of oil, moisture or other contaminants that could remain on the glass and possibly degrade the image. Do not touch the glass window. If oil or smudges remain, use a cotton bud and alcohol (ethyl, methyl, or isopropyl) to clean the window. Do not pour the alcohol on the window.

Clean the Vision Sensor Lens Cover

To remove dust from the lens cover, use a pressurized air duster. The air must be free of oil, moisture or other contaminants that could remain on the lens cover. To clean the plastic window of the lens cover, use a small amount of isopropyl alcohol on a cleaning cloth. Do not scratch the plastic window. Do not pour the alcohol on the plastic window.

