

COGNEX

In-Sight[®] 7000 Series Vision System Optional Configurations



2018 June 07
Revision: 5.6.00010000.1

Legal Notices

The software described in this document is furnished under license, and may be used or copied only in accordance with the terms of such license and with the inclusion of the copyright notice shown on this page. Neither the software, this document, nor any copies thereof may be provided to, or otherwise made available to, anyone other than the licensee. Title to, and ownership of, this software remains with Cognex Corporation or its licensor. Cognex Corporation assumes no responsibility for the use or reliability of its software on equipment that is not supplied by Cognex Corporation. Cognex Corporation makes no warranties, either express or implied, regarding the described software, its merchantability, non-infringement or its fitness for any particular purpose.

The information in this document is subject to change without notice and should not be construed as a commitment by Cognex Corporation. Cognex Corporation is not responsible for any errors that may be present in either this document or the associated software.

Companies, names, and data used in examples herein are fictitious unless otherwise noted. No part of this document may be reproduced or transmitted in any form or by any means, electronic or mechanical, for any purpose, nor transferred to any other media or language without the written permission of Cognex Corporation.

Copyright © 2014 - 2018 Cognex Corporation. All Rights Reserved.

Portions of the hardware and software provided by Cognex may be covered by one or more U.S. and foreign patents, as well as pending U.S. and foreign patents listed on the Cognex web site at: <http://www.cognex.com/patents>.

The following are registered trademarks of Cognex Corporation:

Cognex, 2DMAX, Advantage, Alignplus, Assemblyplus, Check it with Checker, Checker, Cognex Vision for Industry, Cognex VSOC, CVL, DataMan, DisplayInspect, DVT, EasyBuilder, Hotbars, IDMax, In-Sight, Laser Killer, MVS-8000, OmniView, PatFind, PatFlex, PatInspect, PatMax, PatQuick, SensorView, SmartView, SmartAdvisor, SmartLearn, UltraLight, Vision Solutions, VisionPro, VisionView

The following are trademarks of Cognex Corporation:

The Cognex logo, 1DMax, 3D-Locate, 3DMax, BGAll, CheckPoint, Cognex VSoC, CVC-1000, FFD, iLearn, In-Sight (design insignia with cross-hairs), In-Sight 2000, InspectEdge, Inspection Designer, MVS, NotchMax, OCRMax, PatMax RedLine, ProofRead, SmartSync, ProfilePlus, SmartDisplay, SmartSystem, SMD4, VisiFlex, Xpand

Portions copyright © Microsoft Corporation. All rights reserved.

Portions copyright © MadCap Software, Inc. All rights reserved.

Other product and company trademarks identified herein are the trademarks of their respective owners.

Table of Contents

Legal Notices	i
Uninstall and Install the M12 Lens	1
Uninstall the M12 Lens	1
Install the M12 Lens	3
Replace the Cognex Lens Tool Pad	4
Install the Lens Filter	5
Install a Lens Filter with a Shroud	6
Install a Lens Filter without a Shroud	8
Replace the Ring Light	9
Replace a Ring Light with a Shroud	10
Convert to a Ring Light with a Shroud	12
Replace a Ring Light without a Shroud	15
Convert from the M12 Lens to the C-Mount Lens	17
Uninstall the Ring Light	17
Uninstall a Ring Light with a Shroud	18
Uninstall a Ring Light without a Shroud	20
Uninstall the M12 Lens Capsule	21
Install the C-Mount Lens	22
Install the Lighting Bracket	25
Lighting Bracket Kit Components	25
Installation Procedure	26
Lighting Bracket Dimensions	28

Uninstall and Install the M12 Lens

If you purchased a vision system with the pre-installed M12 lens, the lens can be replaced with other M12 lenses. The Cognex Lens Tool accessory (LNS-M12-TOOLKIT) must be used to replace the M12 lens. Please contact your Cognex sales representative for more information.

CAUTION:



- Using a non-Cognex lens or replacing the M12 lens without the Cognex Lens Tool accessory (LNS-M12-TOOLKIT) may cause damage to the vision system.
- Do not remove the entire lens capsule. Once removed, the lens capsule cannot be re-installed. Unauthorized modifications may void your warranty.

Uninstall the M12 Lens



Tip: Before disconnecting the power supply of a vision system, it is recommended to move the M12 lens to the furthest out position by setting the Set Focus Position Value parameter to 100 in In-Sight Explorer. For more information on how to set up the focus position, refer to the EditFocusPosition topic in the *In-Sight® Explorer Help* file provided on the In-Sight Explorer DVD.

1. Verify that the 24VDC power supply being used is unplugged and not receiving power.
2. Remove the lens cover, if present.
3. Place the lens tool directly on the lens, with the padded end of the tool pressed against the lens. The pad will “grab” onto the lens.



Figure 1-1: Place Lens Tool on Lens

4. To loosen the lens, turn the lens tool counter-clockwise.

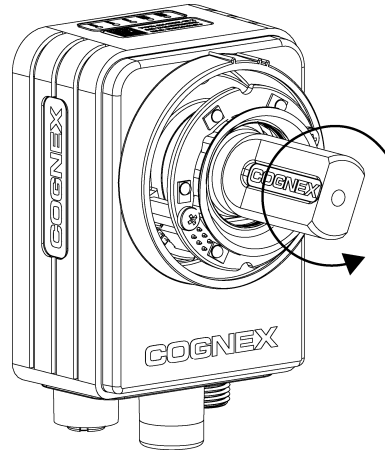

Figure 1-2: Turn Counter-Clockwise

5. Remove the lens.

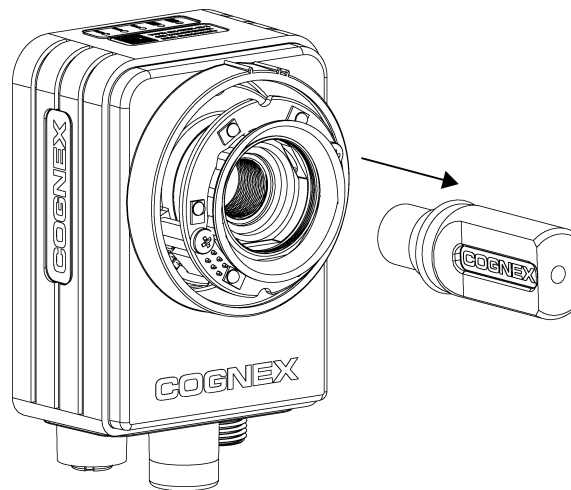

Figure 1-3: Remove the Lens

Install the M12 Lens

1. Verify that the 24VDC power supply being used is unplugged and not receiving power.
2. Determine the correct lens tool to use, based on the focal length of the lens.

Table 1-1: Cognex Lens Tool

Lens Focal Length	Cognex Lens Tool
6MM (LM 12-06-02) 8MM (LM 12-08-02) 12MM (LM 12-12-02) 16MM (LM 12-16-02)	Clear Anodized (P/N 820-0233-xR)
25MM (LM 12-25-02)	Black Anodized (P/N 820-0234-xR)

3. To install the lens, insert the lens and using your fingers, turn it clockwise. If needed, attach the lens tool and finish tightening the lens; the maximum torque is 0.34 Nm (3 in-lb).

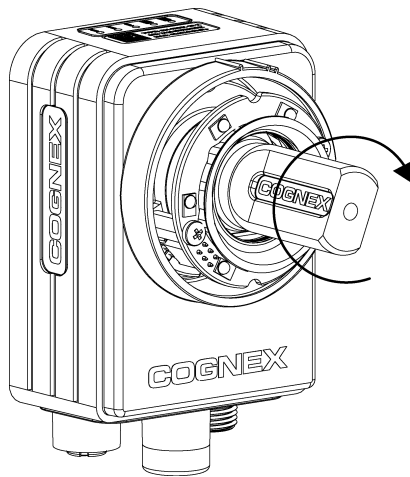

Figure 1-4: Turn Clockwise

4. Reattach the lens cover.
5. Restore power to the 24VDC power supply and turn it on if necessary.

Replace the Cognex Lens Tool Pad

If the Cognex Lens Tool's Pad tears, it can be replaced using one of the pads included with the lens tool.

1. Grab the edge of the existing pad and pull it out of the lens tool.

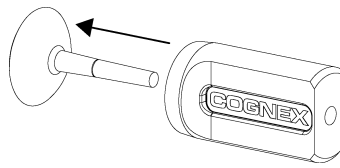

Figure 1-5: Remove Pad

2. Using one of the replacement pads included with the lens tool, feed the stem through the lens tool until the pad is resting firmly on the end of the lens tool.

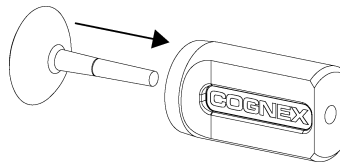

Figure 1-6: Replace Pad

Install the Lens Filter

If you purchased a vision system with the M12 lens configuration, a filter kit is available for purchase. The filter kit can be used to increase the contrast of images and improve the ability of the vision system to distinguish desired characteristics. Please contact your Cognex sales representative for more information.

Table 2-1: Cognex Filter Kit

Lens Filter Color	Lens Filter Part Number
Blue	IMBF-BP470-IS7
Green	IMGF-BP525-IS7
Orange	IMOF-BP590-IS7
Red	IMRF-BP635-IS7
Dark Red	IMRF-BP660-IS7
Infrared	IMIF-BP850-IS7

The steps for installing the lens filter vary, depending on whether the vision system you purchased has a shroud. Refer to the table below to determine the installation steps required for your application.

Table 2-2: Vision System Configurations

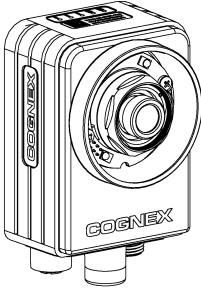
Configuration	Vision System	Installation Instructions
Configuration 1	 <p>Vision System with Shroud</p>	Refer to Install a Lens Filter with a Shroud on page 6 .
Configuration 2	 <p>Vision System without Shroud</p>	Refer to Install a Lens Filter without a Shroud on page 8 .

Install a Lens Filter with a Shroud

If the vision system you purchased has a shroud, complete the following steps to install the lens filter.

1. Verify that the 24VDC power supply being used is unplugged and not receiving power.
2. Remove the lens cover, if present.
3. Using your fingers, remove the shroud.

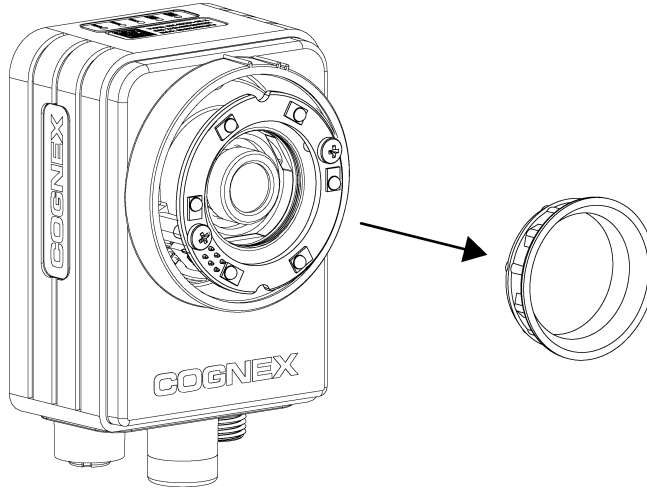

Figure 2-1: Remove Shroud

4. Install the lens filter.
 - a. Hold the lens filter by the sides, with the threaded end towards the lens. Align the filter with the filter thread on the vision system.
 - b. Screw the lens filter onto the vision system by twisting it clockwise until it stops turning.

Note: Make sure to only touch the sides of the filter to avoid leaving fingerprints on the filter.

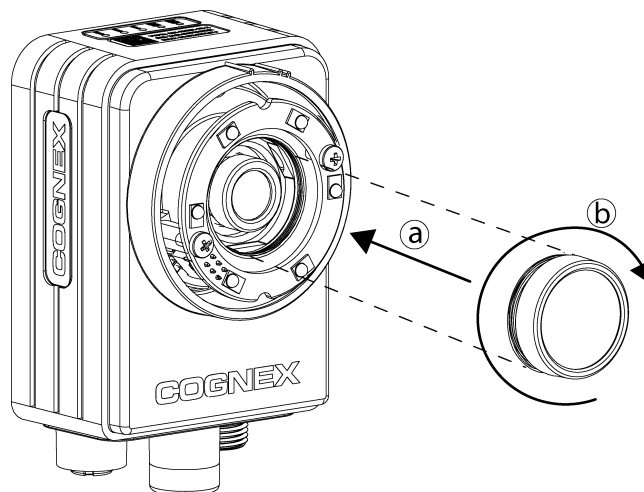

Figure 2-2: Install the Lens Filter

5. Reinstall the shroud to the vision system. Gently press the shroud down into the vision system.

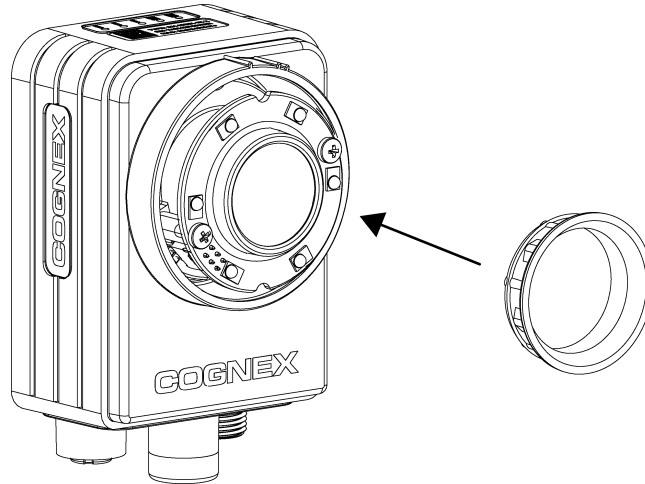

Figure 2-3: Reinstall Shroud

6. Reattach the lens cover.
7. Restore power to the 24VDC power supply and turn it on if necessary.

Install a Lens Filter without a Shroud

If the vision system you purchased does not have a shroud, complete the following steps to install the lens filter.

1. Verify that the 24VDC power supply being used is unplugged and not receiving power.
2. Remove the lens cover, if present.
3. Install the lens filter.
 - a. Hold the lens filter by the sides, with the threaded end towards the lens. Align the filter with the filter thread on the vision system.
 - b. Screw the lens filter onto the vision system by twisting it clockwise until it stops turning.

Note: Make sure to only touch the sides of the filter to avoid leaving fingerprints on the filter.

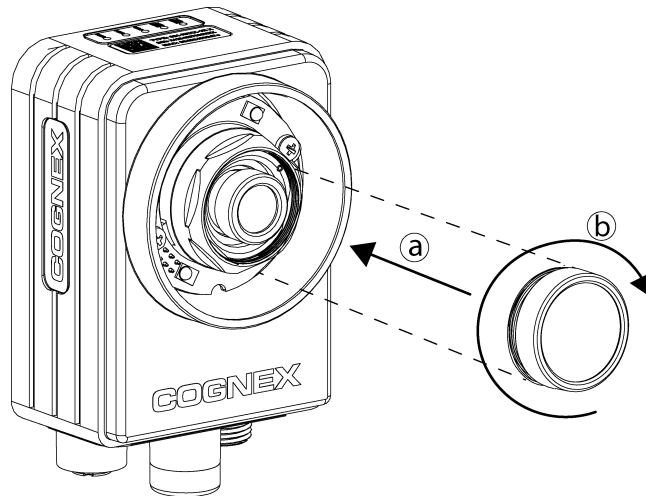

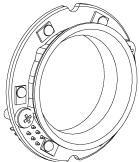
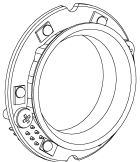
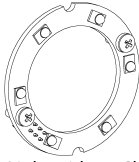
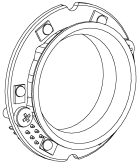
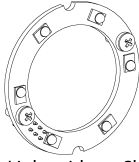

Figure 2-4: Install the Lens Filter

4. Reattach the lens cover.
5. Restore power to the 24VDC power supply and turn it on if necessary.

Replace the Ring Light

If you purchased a vision system with the M12 lens configuration, the vision system is shipped with an internal LED ring light pre-installed. The steps for replacing the ring light vary, depending on whether the pre-installed ring light and the ring light you purchased have a shroud. Refer to the table below to determine the installation steps required for your application.

Table 3-1: Ring Light Configurations

Configuration	Existing Ring Light	Replacement Ring Light	Installation Instructions
Configuration 1	 <p>Ring Light with Shroud</p>	 <p>Ring Light with Shroud</p>	Refer to Replace a Ring Light with a Shroud on page 10 .
Configuration 2	 <p>Ring Light without Shroud</p>	 <p>Ring Light with Shroud</p>	Refer to Convert to a Ring Light with a Shroud on page 12 .
Configuration 3	 <p>Ring Light without Shroud</p>	 <p>Ring Light without Shroud</p>	Refer to Replace a Ring Light without a Shroud on page 15 .

Replace a Ring Light with a Shroud

If the pre-installed ring light on your vision system has a shroud, please complete the following steps to replace the ring light.

1. Verify that the 24VDC power supply being used is unplugged and not receiving power.
2. Remove the lens cover, if present.
3. Loosen the ring light.
 - a. Using a screwdriver, loosen the two screws on the ring light.

Note: Do not attempt to remove the screws from the ring light; the screws are held in place with washers on the back of the ring light.

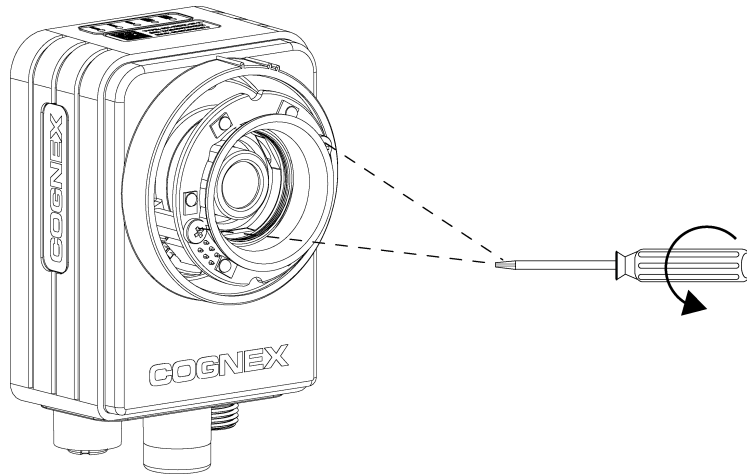

Figure 3-1: Loosen Ring Light

- b. Pins on the back of the ring light are connected to the vision system. Grab the notch on the ring light that is closest to the pins, and gently pull up to disengage the pins from the vision system.
4. Remove the ring light and shroud from the vision system.

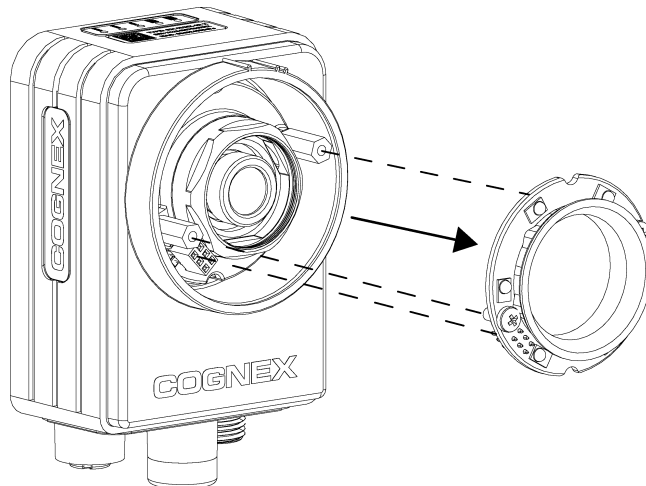

Figure 3-2: Remove Ring Light and Shroud

5. To install the new ring light, align the screws with the threaded screw posts on the vision system. Also align the pins on the back of the ring light with the connector on the vision system, but do not attempt to connect the pins.

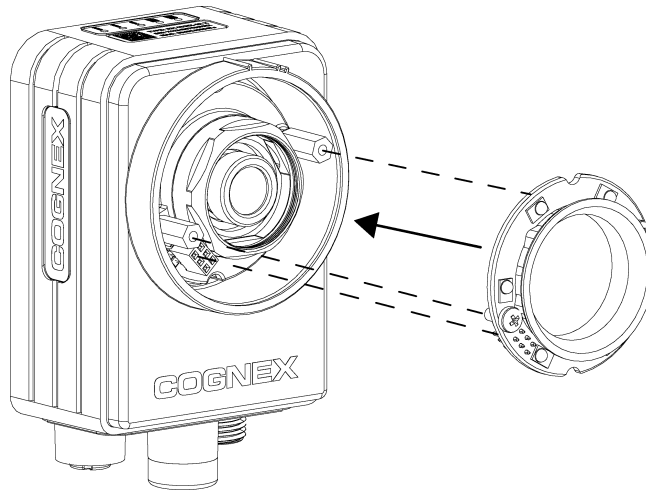

Figure 3-3: Align the Screws and Pins

6. Gently press down on the ring light to connect the pins on the back of the ring light to the vision system.
7. Using a screwdriver, tighten the screws until they stop turning; the maximum torque is 0.56 Nm (5 in-lb).

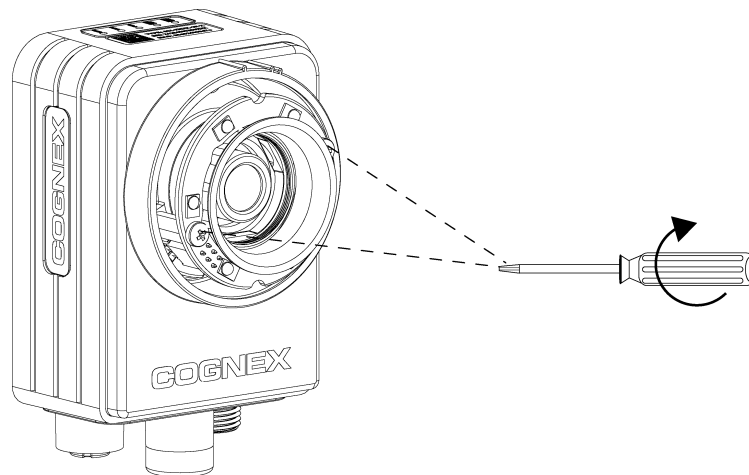

Figure 3-4: Partially Tighten the Screws

8. Reattach the lens cover.
9. Restore power to the 24VDC power supply and turn it on if necessary.

Convert to a Ring Light with a Shroud

If the pre-installed ring light does not have a shroud, and you need to convert to a ring light with a shroud, please complete the following steps. To install a ring light with a shroud, you must first install the Cognex Standoff and Connector Kit (LM12-UPDATE). Please contact your Cognex sales representative for more information.

1. Verify that the 24VDC power supply being used is unplugged and not receiving power.
2. Remove the lens cover, if present.
3. Loosen the ring light.
 - a. Using a screwdriver, loosen the two screws on the ring light.

Note: Do not attempt to remove the screws from the ring light; the screws are held in place with washers on the back of the ring light.

- b. Pins on the back of the ring light are connected to the vision system. Using small tweezers, grab the notch on the ring light that is closest to the pins, and gently pull up to disengage the pins from the vision system.

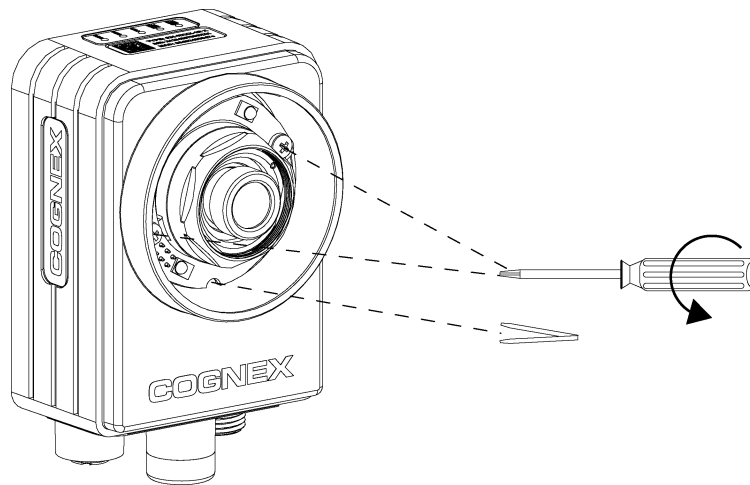

Figure 3-5: Loosen Ring Light

4. Remove the ring light from the vision system.

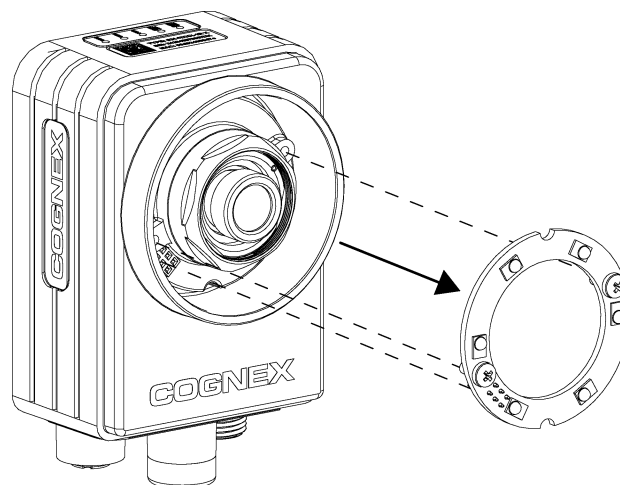

Figure 3-6: Remove Ring Light

5. Install the Cognex Standoff and Connector Kit (LM12-UPDATE).
 - a. Insert the light connector into the connector on the vision system.

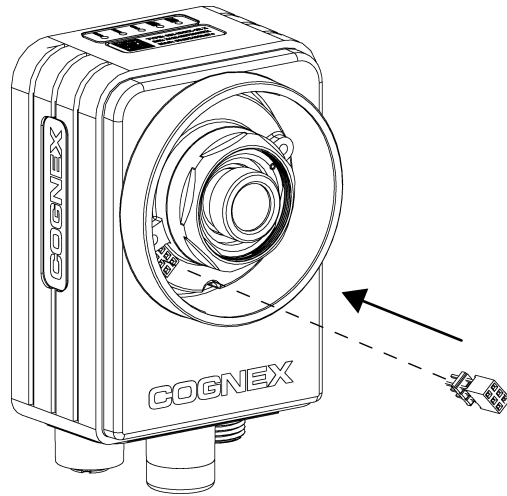

Figure 3-7: Install the Light Connector

- b. Align the posts with the threaded screw holes on the vision system. Using a post wrench, tighten the posts until they stop turning; the maximum torque is 0.56 Nm (5 in-lb).

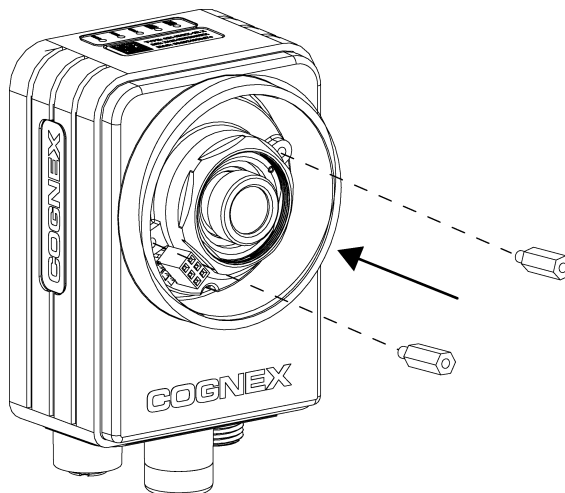

Figure 3-8: Install the Posts

6. To install the new ring light, align the screws with the threaded screw posts on the vision system. Also align the pins on the back of the ring light with the connector on the vision system, but do not attempt to connect the pins.

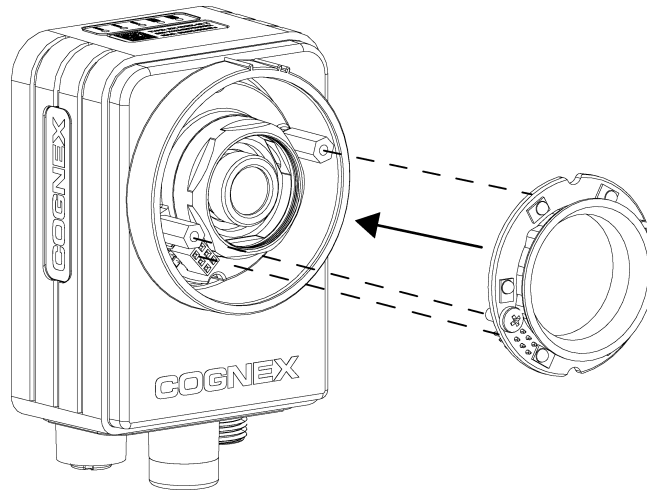

Figure 3-9: Align the Screws and Pins

7. Gently press down on the ring light to connect the pins on the back of the ring light to the vision system.
8. Using a screwdriver, tighten the screws until they stop turning; the maximum torque is 0.56 Nm (5 in-lb).

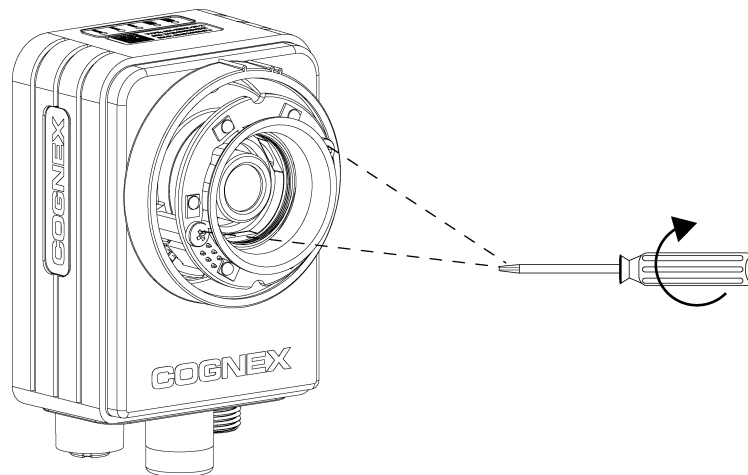

Figure 3-10: Partially Tighten the Screws

9. Reattach the lens cover.
10. Restore power to the 24VDC power supply and turn it on if necessary.

Replace a Ring Light without a Shroud

If the pre-installed ring light on your vision system does not have a shroud, and you need to replace it with another ring light that also does not have a shroud, please complete the following steps.

1. Verify that the 24VDC power supply being used is unplugged and not receiving power.
2. Remove the lens cover, if present.
3. Loosen the ring light.
 - a. Using a screwdriver, loosen the two screws on the ring light.

Note: Do not attempt to remove the screws from the ring light; the screws are held in place with washers on the back of the ring light.

- b. Pins on the back of the ring light are connected to the vision system. Using small tweezers, grab the notch on the ring light that is closest to the pins, and gently pull up to disengage the pins from the vision system.

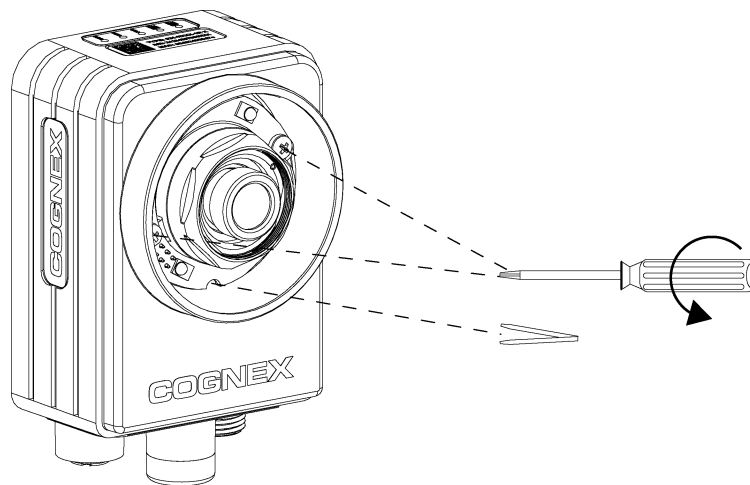

Figure 3-11: Loosen Ring Light

4. Remove the ring light from the vision system.

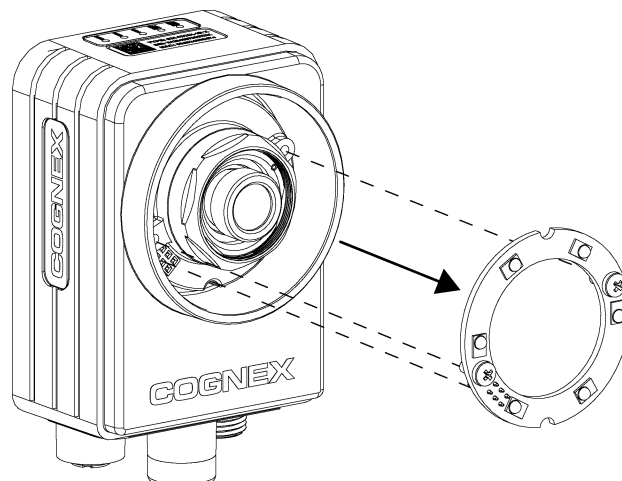

Figure 3-12: Remove Ring Light

5. To install the new ring light, align the screws with the threaded screw holes on the vision system. Also align the pins on the back of the ring light with the connector on the vision system, but do not attempt to connect the pins.

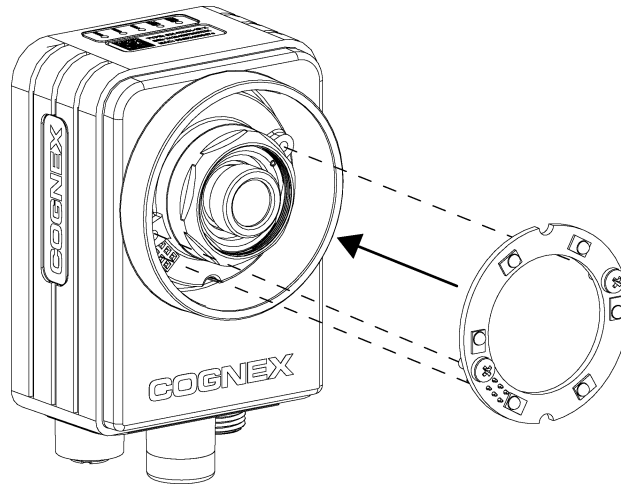

Figure 3-13: Align the Screws and Pins

6. Using a screwdriver, tighten the screws until they are partially threaded.

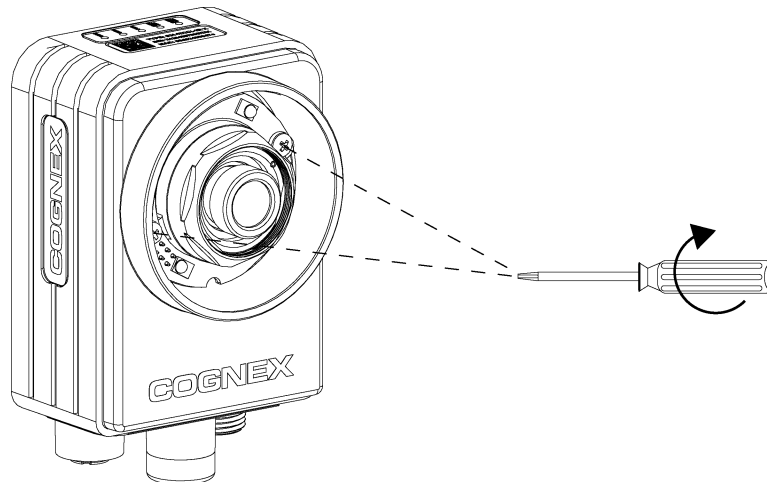

Figure 3-14: Partially Tighten the Screws

7. Gently press down on the ring light to connect the pins on the back of the ring light to the vision system.

⚠ CAUTION: If the screws are not partially threaded prior to connecting the pins, the pins may bend or break.

8. Using a screwdriver, finish tightening the screws.
 - a. If installing a ring light that uses nylons screws, gently tighten the screws until a slight change in resistance is detected.

⚠ CAUTION: Use caution when tightening the nylon screws, to ensure the screws do not become stripped.

- b. If installing a ring light that uses stainless steel screws, the maximum torque is 0.56 Nm (5 in-lb).

9. Reattach the lens cover.
10. Restore power to the 24VDC power supply and turn it on if necessary.

Convert from the M12 Lens to the C-Mount Lens

If you purchased a vision system with the pre-installed M12 lens, the M12 lens can be replaced with a C-Mount lens. Please complete the following steps to convert from the M12 lens to the C-Mount lens.

CAUTION: The conversion is irreversible. Once the vision system is converted from the M12 lens to the C-Mount lens, it cannot be converted back to the M12 lens.

Uninstall the Ring Light

The steps for uninstalling the ring light vary, depending on whether the pre-installed ring light has a shroud.

Table 4-1: Vision System Configurations

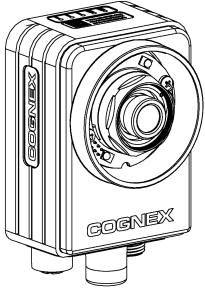
Configuration	Vision System	Installation Instructions
Configuration 1	 <p>Vision System with Shroud</p>	Refer to Uninstall a Ring Light with a Shroud on page 18 .
Configuration 2	 <p>Vision System without Shroud</p>	Refer to Uninstall a Ring Light without a Shroud on page 20 .

Uninstall a Ring Light with a Shroud

If the pre-installed ring light on your vision system has a shroud, please complete the following steps to remove the ring light.

1. Verify that the 24VDC power supply being used is unplugged and not receiving power.
2. Remove the lens cover, if present.
3. Loosen the ring light.
 - a. Using a screwdriver, loosen the two screws on the ring light.

Note: Do not attempt to remove the screws from the ring light; the screws are held in place with washers on the back of the ring light.

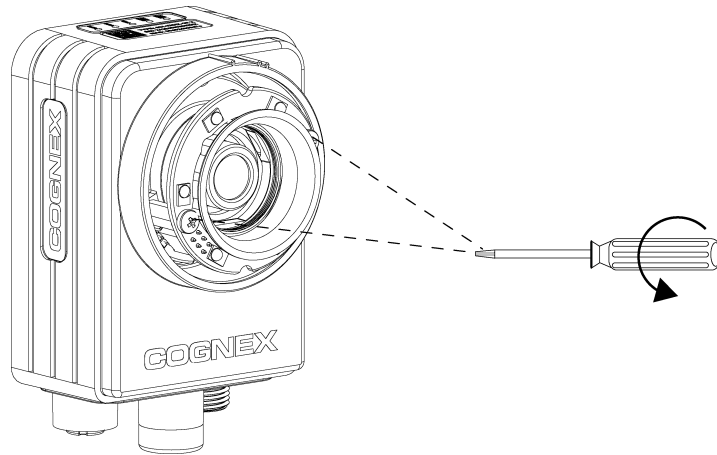

Figure 4-1: Loosen Ring Light

- b. Pins on the back of the ring light are connected to the vision system. Grab the notch on the ring light that is closest to the pins, and gently pull up to disengage the pins from the vision system.
4. Remove the ring light and shroud from the vision system.

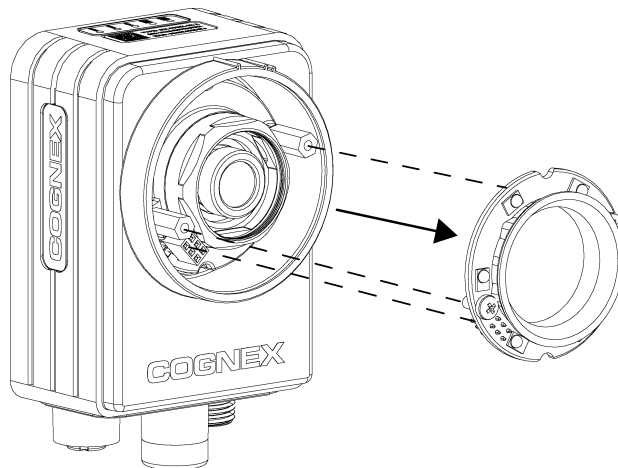

Figure 4-2: Remove Ring Light and Shroud

5. Remove the posts from the vision system.

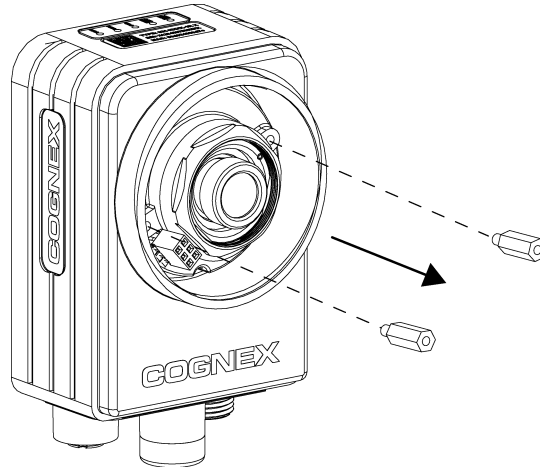

Figure 4-3: Remove Posts

6. Remove the light connector from the vision system.

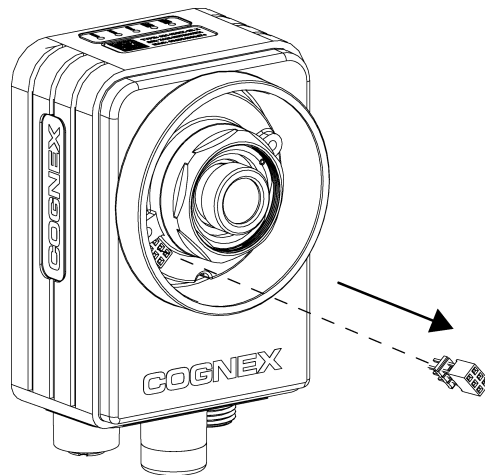

Figure 4-4: Remove Light Connector

Uninstall a Ring Light without a Shroud

If the pre-installed ring light on your vision system does not have a shroud, please complete the following steps to remove the ring light.

1. Verify that the 24VDC power supply being used is unplugged and not receiving power.
2. Remove the lens cover, if present.
3. Loosen the ring light.
 - a. Using a screwdriver, loosen the two screws on the ring light.

Note: Do not attempt to remove the screws from the ring light; the screws are held in place with washers on the back of the ring light.

- b. Pins on the back of the ring light are connected to the vision system. Using small tweezers, grab the notch on the ring light that is closest to the pins, and gently pull up to disengage the pins from the vision system.

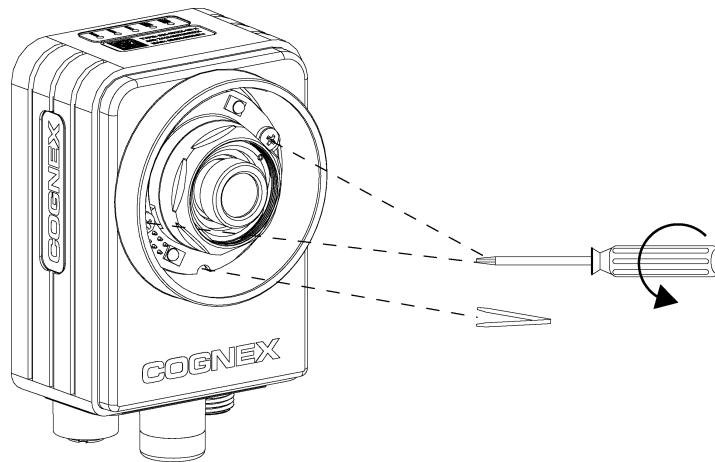

Figure 4-5: Loosen Ring Light

4. Remove the ring light from the vision system.

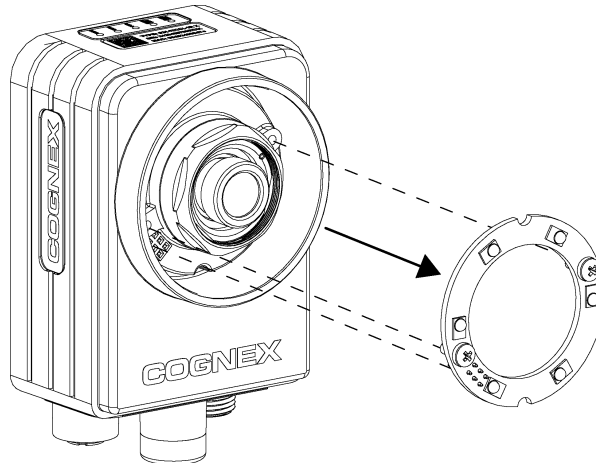

Figure 4-6: Remove Ring Light

Uninstall the M12 Lens Capsule

1. Position a 25mm hex socket on the lens capsule.

Note: The 25mm hex socket is used to remove the entire lens capsule. Do not use the Cognex lens tool to remove only the M12 lens when converting from the M12 lens to the C-Mount lens.

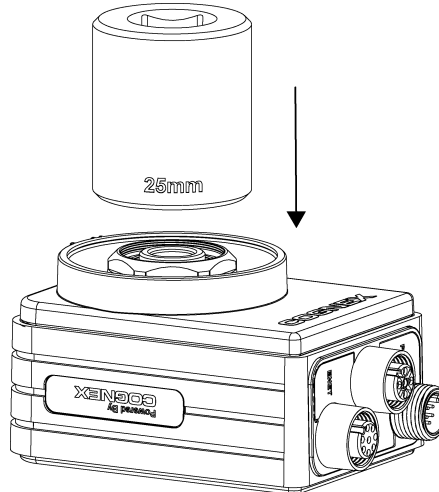

Figure 4-7: Place a 25mm Socket on Lens Capsule

2. To loosen the lens capsule, turn the hex socket counter-clockwise.
3. Remove the entire lens capsule.

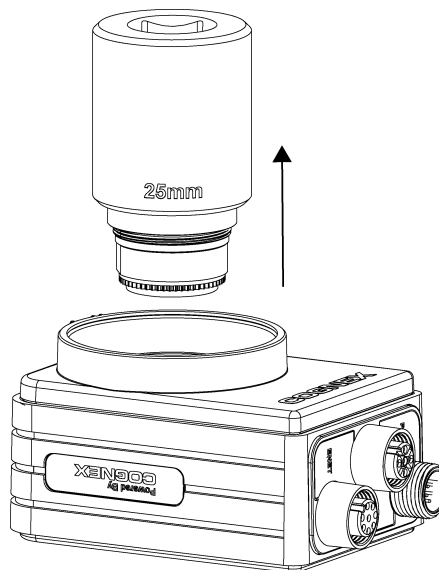

Figure 4-8: Remove the Lens Capsule

4. Discard the lens capsule.

Note: Once removed, the lens capsule must be discarded and cannot be re-installed in another vision system.

Install the C-Mount Lens

Note: Autofocus is not supported for the C-Mount lens configuration.

1. Attach a C-Mount lens to the vision system. The exact lens focal length needed depends on the working distance and the field of view required for your machine vision application.

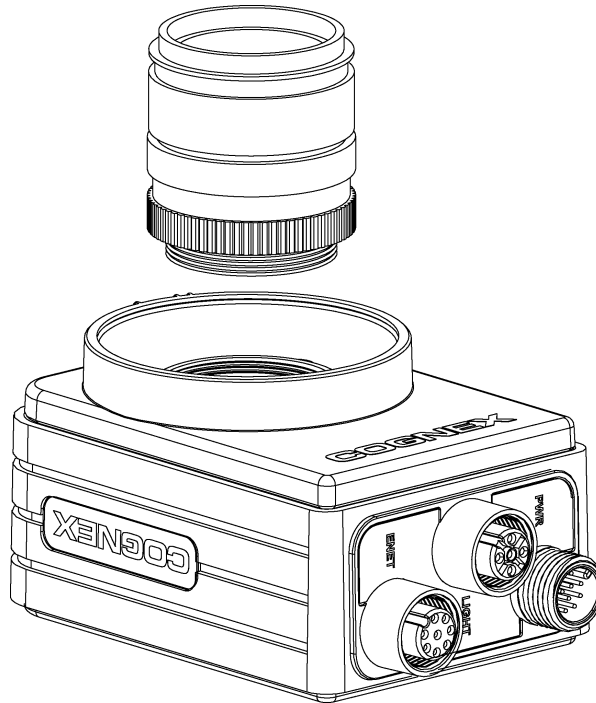

Figure 4-9: Install the C-Mount Lens

- If using a lens cover, attach the lens cover to the vision system.

Note: The lens cover for C-Mount lens is available for purchase separately. For more information, please contact your Cognex sales representative.

- Align the keys on each side of the lens cover with the notches on the vision system, then push the lens cover down to the vision system until it stops moving.

CAUTION: The lens cover is "keyed" to fit the vision system; do not force the connections or damage may occur.

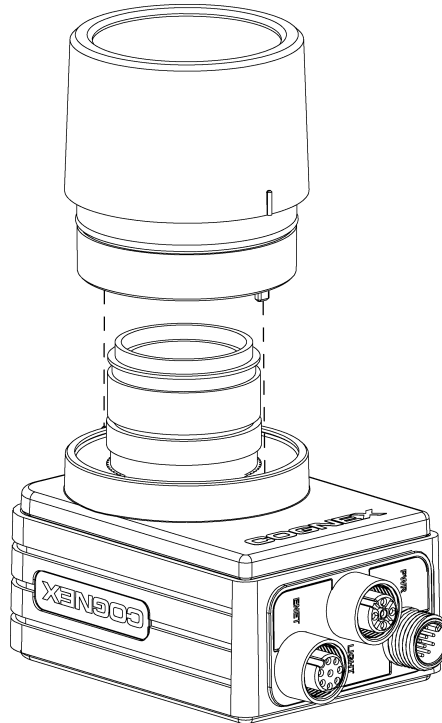

Figure 4-10: Install the Lens Cover

- Turn the lens cover clockwise until it is in the locked position.

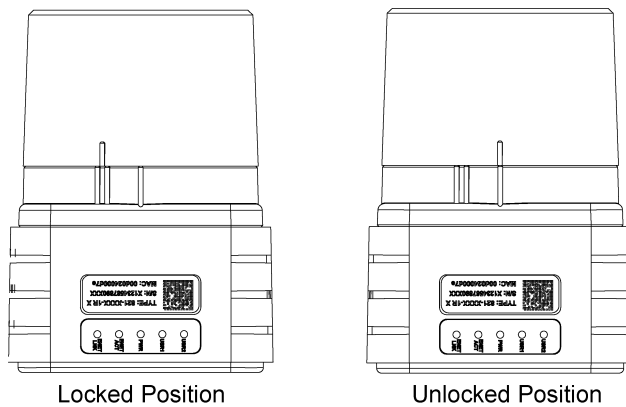

Figure 4-11: Locked and Unlocked Lens Cover Positions

Install the Lighting Bracket

The lighting bracket kit can be used to attach the external LED bar lights to the vision system to provide an integrated and flexible lighting solution. The lighting bracket kit is available for purchase as an optional accessory.

Note: The external LED bar lights and cables are sold separately. For a complete list of available LED bar lights, please contact your Cognex sales representative.

Table 5-1: Lighting Bracket Kit

Part Number	Linear Increment	Angular Increment
BKT-7K-04	5.5 mm	30°

Table 5-2: Cables

Part Number	Description
IC00-ADAP-02	Single light connection
IC00-ADAP-03	Dual light connection

Lighting Bracket Kit Components

The lighting bracket kit is shipped with the components listed below.

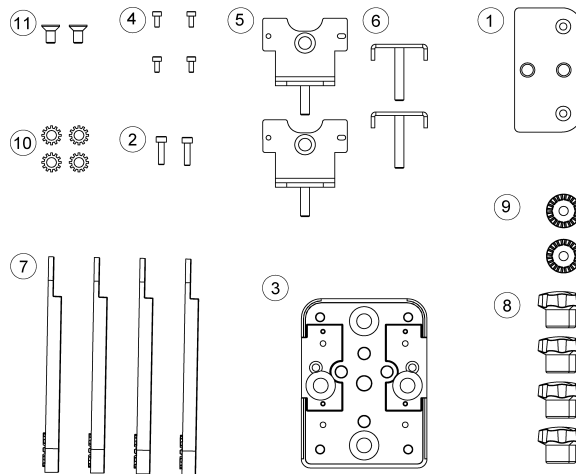

Figure 5-1: Lighting Bracket Kit Components

Table 5-3: Lighting Bracket Kit Components

Item #	Description (Qty)
1	Small mounting bracket (1)
2	M3x12 socket head cap screws (2)
3	Mounting bracket plate (1)
4	M3x6 socket head cap screws (4)
5	90° arm-base mounting brackets (2)
6	Pivot brackets (2)
7	Lighting bracket arms (4)
8	Star knobs (4)
9	Pivot rotation keys (2)
10	M4 external tooth washers (4)
11	M4x5 socket head flat head screws (2)

Installation Procedure

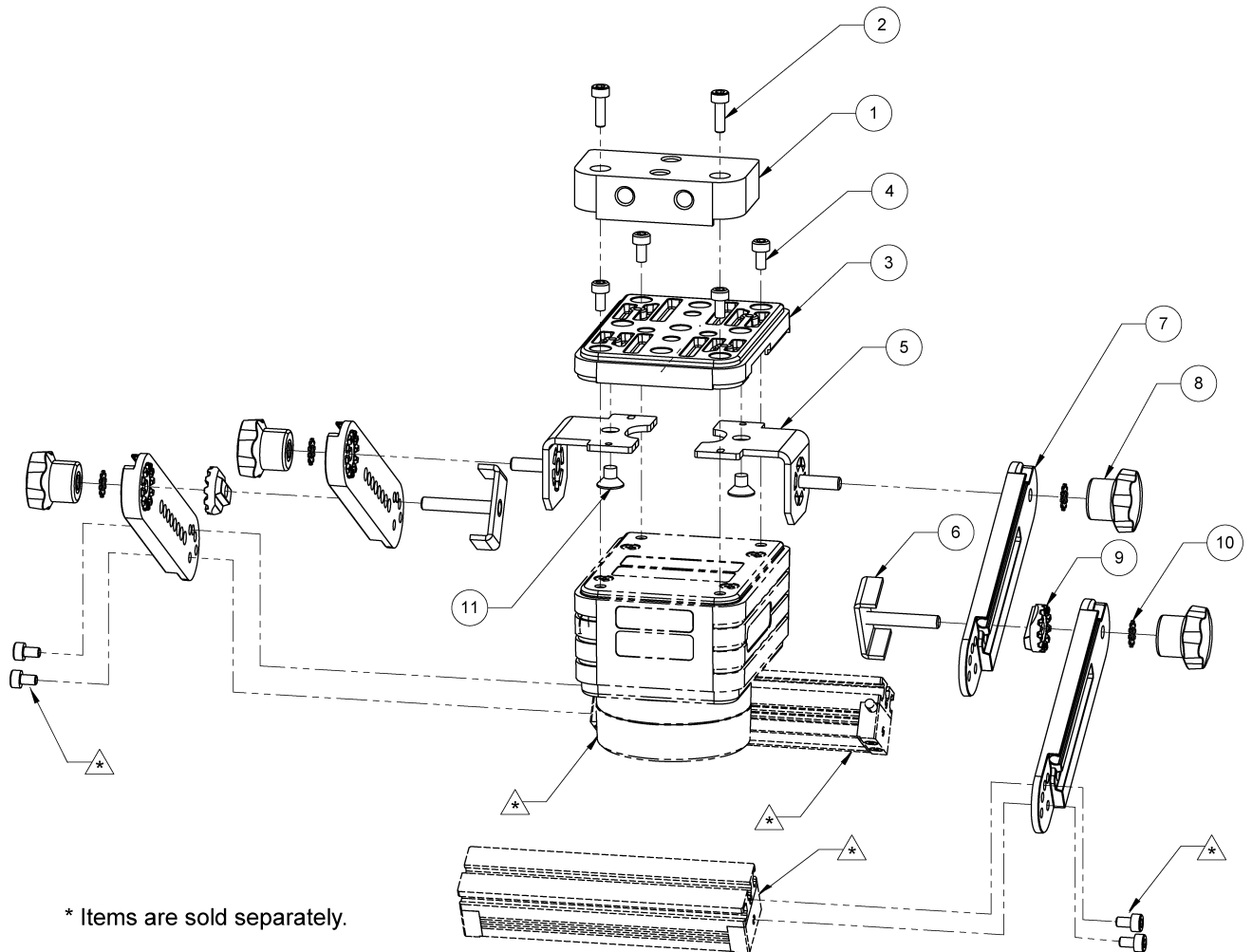

Figure 5-2: Install the Lighting Bracket

To install the lighting bracket:

1. Attach both parts of the 90° arm-base mounting bracket (item 5) to the mounting bracket plate (item 3) using M4x5 screws (item 11).
2. Attach the assembly to the In-Sight 7000 series vision system using M3x6 screws (item 4).

Note: If using small mounting bracket (item 1), attach the assembly to the In-Sight 7000 series vision system using only two of the M3x6 screws (item 4). Then attach the small mounting bracket to the mounting bracket plate (item 3) using M3x12 screws (item 2).

3. Place the lighting bracket arm (item 7) to the screw stud on the 90° arm-base mounting bracket (item 5). Adjust the angle accordingly.
4. Place the M4 external tooth washer (item 10) to the screw stud on the 90° arm-base mounting bracket (item 5).
5. Screw the star knob (item 8) onto the 90° arm-base mounting bracket (item 5) and then tighten the screw.

6. Insert the pivot bracket (item 6) into the incremental hold on the lighting bracket arm (item 7).

Note: The lighting bracket arm length can be adjusted according to your needs. The linear increment on the arm is 5.5 mm.

7. Place the pivot rotation key (item 9) on the screw stud of the pivot bracket (item 6). Align the key with the groove on the arm.
8. Place another lighting bracket arm (item 7) on the screw stud of the pivot bracket (item 6). Adjust the angle accordingly.
9. Place the M4 external tooth washer (item 10) on the screw stud of the pivot bracket (item 6).
10. Screw the star knob (item 8) onto the pivot bracket (item 6) and then tighten the screw.
11. Attach the external LED bar light to the lighting bracket arm (item 7) with screws provided with the LED bar light kit.

Note: The screws for external LED bar lights are not included in the lighting bracket kit.

12. Repeat steps 3 to 11 to install the other side of the lighting bracket.

Tip: The LED bar light cable can be routed in the groove on the lighting bracket arm (item 7).

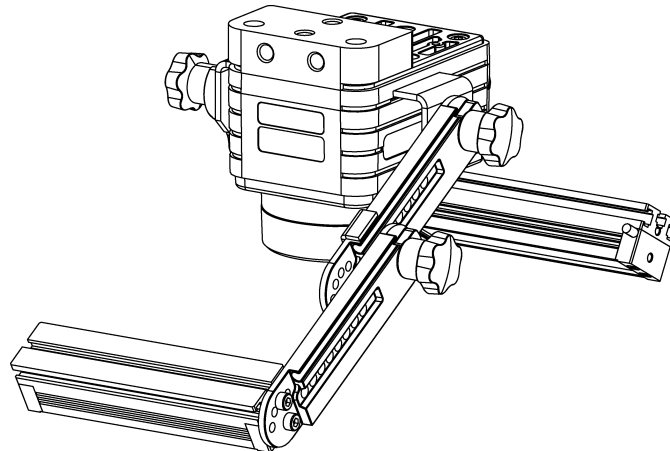

Figure 5-3: Vision System with Lighting Bracket Assembled

Lighting Bracket Dimensions

Note:



- All dimensions are in millimeters [inches] and are for reference purposes only.
- All specifications may be changed without notice.

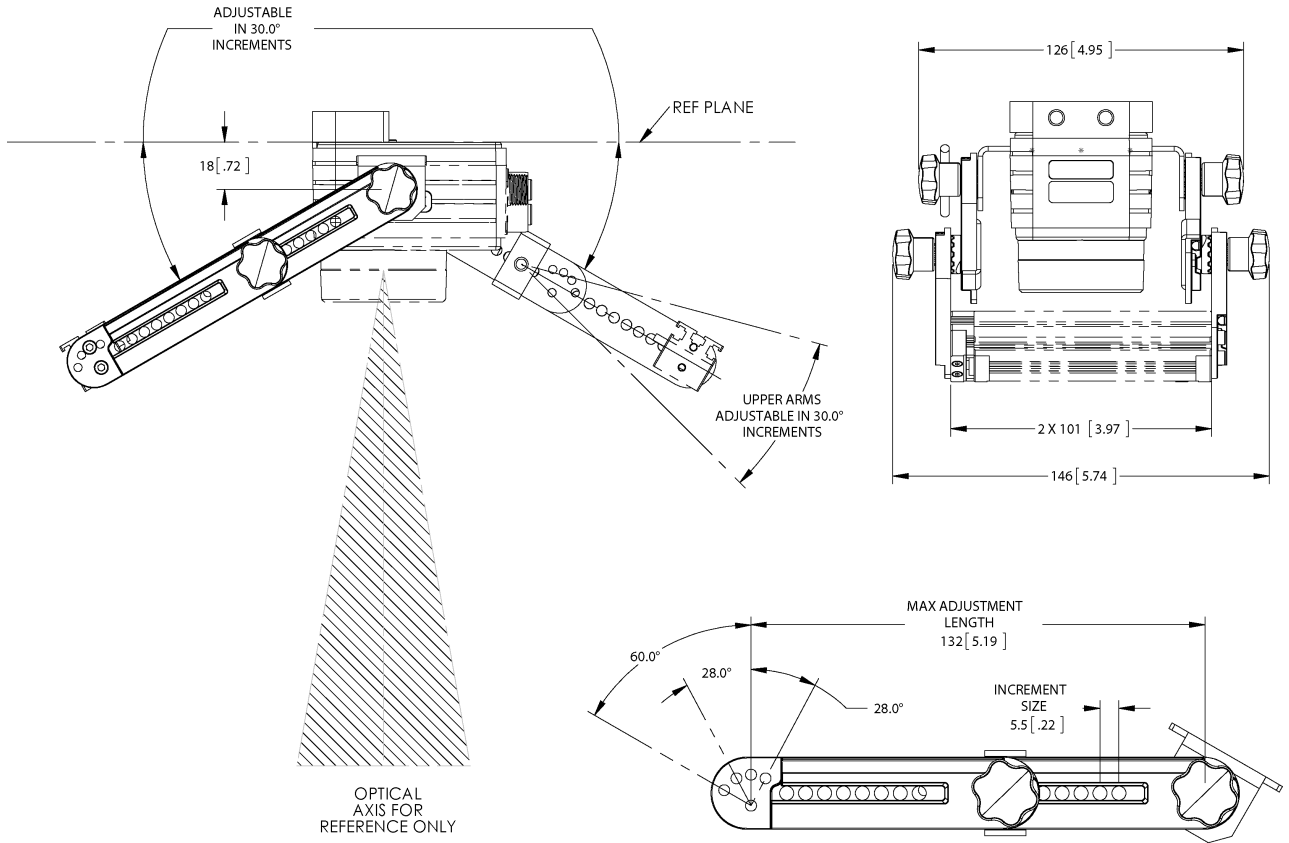

Figure 5-4: Lighting Bracket Dimensions

