

## DataMan<sup>®</sup> 260 Series Reference Manual



2020 August 13  
Revision: 6.1.9.1

# Legal Notices

The software described in this document is furnished under license, and may be used or copied only in accordance with the terms of such license and with the inclusion of the copyright notice shown on this page. Neither the software, this document, nor any copies thereof may be provided to, or otherwise made available to, anyone other than the licensee. Title to, and ownership of, this software remains with Cognex Corporation or its licensor. Cognex Corporation assumes no responsibility for the use or reliability of its software on equipment that is not supplied by Cognex Corporation. Cognex Corporation makes no warranties, either express or implied, regarding the described software, its merchantability, non-infringement or its fitness for any particular purpose.

The information in this document is subject to change without notice and should not be construed as a commitment by Cognex Corporation. Cognex Corporation is not responsible for any errors that may be present in either this document or the associated software.

Companies, names, and data used in examples herein are fictitious unless otherwise noted. No part of this document may be reproduced or transmitted in any form or by any means, electronic or mechanical, for any purpose, nor transferred to any other media or language without the written permission of Cognex Corporation.

Copyright © 2020. Cognex Corporation. All Rights Reserved.

Portions of the hardware and software provided by Cognex may be covered by one or more U.S. and foreign patents, as well as pending U.S. and foreign patents listed on the Cognex web site at: [cognex.com/patents](http://cognex.com/patents).

---

The following are registered trademarks of Cognex Corporation:

Cognex, 2DMAX, Advantage, AlignPlus, Assemblyplus, Check it with Checker, Checker, Cognex Vision for Industry, Cognex VSOC, CVL, DataMan, DisplayInspect, DVT, EasyBuilder, Hotbars, IDMax, In-Sight, Laser Killer, MVS-8000, OmniView, PatFind, PatFlex, PatInspect, PatMax, PatQuick, SensorView, SmartView, SmartAdvisor, SmartLearn, UltraLight, Vision Solutions, VisionPro, VisionView

The following are trademarks of Cognex Corporation:

The Cognex logo, 1DMax, 3D-Locate, 3DMax, BGAll, CheckPoint, Cognex VSoC, CVC-1000, FFD, iLearn, In-Sight (design insignia with cross-hairs), In-Sight 2000, InspectEdge, Inspection Designer, MVS, NotchMax, OCRMax, PatMax RedLine, ProofRead, SmartSync, ProfilePlus, SmartDisplay, SmartSystem, SMD4, VisiFlex, Xpand

Portions copyright © Microsoft Corporation. All rights reserved.

Portions copyright © MadCap Software, Inc. All rights reserved.

Other product and company trademarks identified herein are the trademarks of their respective owners.

# Table of Contents

<b>Legal Notices</b> .....	<b>2</b>
<b>Table of Contents</b> .....	<b>3</b>
<b>Symbols</b> .....	<b>5</b>
<b>Getting Started</b> .....	<b>6</b>
About DataMan 260 .....	6
Configuration .....	6
DataMan 260 Accessories .....	7
Lens Options .....	7
Filters .....	8
Lens Covers .....	9
Light Options .....	9
Cables .....	10
Power Supplies .....	10
Mounting Brackets .....	10
DataMan 260 Systems .....	11
Model Variants .....	11
Communication Modules .....	11
Ethernet Interfaces .....	11
Reader Layout .....	12
Indicator LEDs .....	13
Changing Orientation .....	13
Dimensions .....	15
Dimensional Drawings .....	16
DataMan 260 Specifications .....	17
DataMan 260 Series Imager Specifications .....	18
LED Wavelengths .....	18
Illumination Options .....	19
<b>Setting Up Your DataMan 260</b> .....	<b>20</b>
Installing an Optical Filter .....	20
Installing a Liquid Lens .....	21
Changing a 6.2 mm Lens to a 16 mm Lens .....	23
Changing to an Illumination with a Different Color .....	25
Mounting .....	27
Right-Angle Configuration .....	27
Field of View and Reading Distances .....	28
DataMan 260 Readers with a 6.2 mm Lens .....	28
DataMan 260 Readers with a 16 mm Lens .....	29
Connections, Optics and Lighting .....	31
5m I/O Breakout Cable (CCBL-05-01) .....	31
5m I/O Breakout Cable (CCB-M12x12Fy-xx) .....	32
15m I/O Breakout Cable (CCB-PWRIO-15) .....	33
Acquisition Triggering .....	34
High Speed Output Lines .....	34
High-Speed Output Wiring .....	35
5m RS-232 Connection Cable (CCB-M12XDB9Y-05) .....	36
Ethernet Cables .....	37

Multi-port Connections .....	38
<b>Using Your DataMan 260 .....</b>	<b>41</b>
Installing the DataMan Software .....	41
Industrial Protocols .....	41
Setting the Focus Position .....	42
Tuning .....	43
External Triggering and Trigger Modes .....	43
Training and Trigger Modes .....	44
Training .....	44
Incremental Training for Multiple Symbologies .....	45
<b>Cleaning and Maintenance .....</b>	<b>46</b>
Cleaning the Reader Housing .....	46
Cleaning the Reader Lens Cover .....	46
<b>Precautions .....</b>	<b>47</b>
<b>Regulations/Conformity .....</b>	<b>48</b>

# Symbols

The following symbols indicate safety precautions and supplemental information:

---

 **WARNING:** This symbol indicates a hazard that could cause death, serious personal injury or electrical shock.

---

---

 **CAUTION:** This symbol indicates a hazard that could result in property damage.

---

---

 **Note:** This symbol indicates additional information about a subject.

---

---

 **Tip:** This symbol indicates suggestions and shortcuts that might not otherwise be apparent.

---

# Getting Started

This section provides general information about the DataMan 260 series readers as well as about the DataMan 260 accessories and systems.

## About DataMan 260

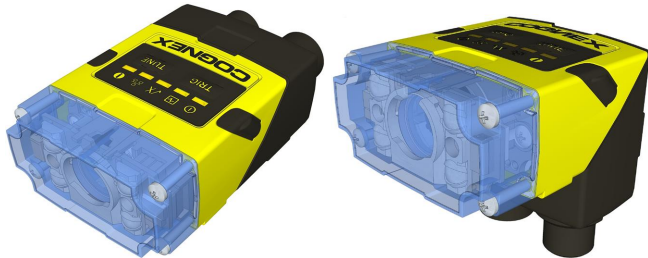

The DataMan 260 readers are best in class ID readers, offering superior performance with the latest ID tools, flexibility to configure the reader in terms of lighting and optics to optimize the application, and an ease-of-use giving the user the ability to setup and deploy an application quickly and efficiently all without the need for PC:

- Superior performance, 1-D and 2-D code reading, including HotBars2™ and patent-pending PowerGrid™
- Flexible optics/lighting, including field upgrades, allowing for the protection of your investment
- Ease-of-use, including an auto-tune and trigger button on the reader, the ability to configure the reader in a straight or right-angle orientation and auto-focus capability utilizing a liquid lens

The DataMan 260 readers provide support for Ethernet and RS-232 communications.

Key highlights:

- 1DMax with HotBars2™, best in class 1-D reading, 2DMax with PowerGrid™, best in class 2-D reading. Reading codes no other ID reader on the market can.
- Multiple options for LED lighting, along with optical filters and polarizing filters. Options for different powered lens, with autofocus capabilities for each.

## Configuration

This document provides basic information about how to configure and use DataMan 260 readers. Additional information is available through the Windows **Start** menu or the DataMan Setup Tool **Help** menu after you install the DataMan software on your PC:

- The **DataMan Communications and Programming Guide** shows you how to integrate your DataMan reader into your particular automation and factory environment.

Cognex->DataMan Software v x.x.x->Documentation->Communications->DataMan Communications and Programming Guide

- The **DataMan Industrial Protocols Manual** provides information on how to integrate DataMan readers into your particular environment using industrial protocols.

Cognex->DataMan Software v x.x.x->Documentation->Communications->DataMan Industrial Protocols Manual

- The **DataMan Reader Configuration Codes** document provides printable 2-D codes that you can use to configure the DataMan reader.

Cognex->DataMan Software v x.x.x->Documentation->English->Reader Configuration Codes

- The **DM260 Quick Reference Guide** provides essential information about the DM260 readers.  
Cognex->DataMan Software v x.x.x->Documentation->English->DM260 Series->DM260 Quick Reference Guide
- The **DataMan Fixed-Mount Readers Reference** is a complete online hardware reference for the DataMan fixed-mount ID readers.  
Cognex->DataMan Software v x.x.x->Documentation->English->DM260 ->Fixed-Mount Reference Manual
- The **DataMan Questions and Answers** document provides context-sensitive information. You can view this help inside the DataMan Setup Tool or as a stand-alone help file.  
Cognex->DataMan Software v x.x.x->Documentation->DM260->Questions and Answers
- The **DataMan Control Commands** lists DataMan Control Commands with all relevant information. You can view this help inside the Setup Tool or as a stand-alone help file.  
Cognex->DataMan Software v x.x.x->Documentation->English->DataMan Control Commands
- The **Setup Tool Reference Manual** describes the user interface of the DataMan Setup Tool software.  
Cognex->DataMan Software v x.x.x->Documentation->English->Setup Tool Reference Manual
- The **Release Notes** list detailed system requirements and additional information about this DataMan software release.  
Cognex->DataMan Software v x.x.x->Documentation->DataMan v x.x.x Release Notes

## DataMan 260 Accessories

### Lens Options

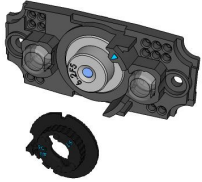
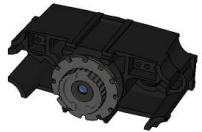

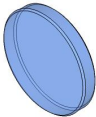
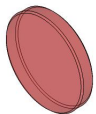

Accessory Name and Number	Accessory Image
6.2 mm lens kit (DM150-LENS-62) <ul style="list-style-type: none"> <li>• 6.2 mm optics mount</li> <li>• 6.2 mm lens</li> <li>• manual lens cap (assembled)</li> <li>• screws</li> </ul>	
16 mm lens with extended optics mount (requires the use of an extended front cover and high-powered red LED) (DM260-LENS-16) <ul style="list-style-type: none"> <li>• 16 mm optics mount</li> <li>• 16 mm lens</li> <li>• manual lens cap (assembled)</li> <li>• screws</li> </ul>	

<p>IR 6.2 mm lens kit, 3-position with IR LED (DMA-KIT-IR-62)</p> <ul style="list-style-type: none"> <li>• 6.2 mm optics mount</li> <li>• 6.2 mm lens (IR)</li> <li>• Standard Infrared Light for 6.2mm (Risk Group Exempt acc. IEC62471)</li> <li>• manual lens cap (not assembled)</li> <li>• screws</li> </ul>	
<p>UV Light Kit for 6.2 mm lens (DMA-KIT-UV365-62)</p> <ul style="list-style-type: none"> <li>• UV light board (365nm wavelength)</li> <li>• UV resistant front cover</li> <li>• screws</li> </ul>	
<p>IR 16 mm lens kit (DMA-KIT-IR-16)</p> <ul style="list-style-type: none"> <li>• 16 mm optics mount</li> <li>• 16 mm lens (IR)</li> <li>• Standard Infrared Light for 16mm (Risk Group Exempt acc. IEC62471)</li> <li>• manual lens cap (assembled)</li> <li>• screws</li> </ul>	
<p>Liquid Lens Module (LLM) to be used with 6.2 mm lens or 16 mm lens (DMA-LLM-150-260)</p>	
<p>16 mm lens with ImageMax kit (DM260-KIT-16LL)</p> <ul style="list-style-type: none"> <li>• 16 mm optics mount</li> <li>• 16 mm lens</li> <li>• Liquid Lens Module (DMA-LLM-150-260)</li> <li>• High Powered red LED illumination (DM260-LED-RED-HP) (Risk Group Exempt acc. IEC62471)</li> <li>• 2-LED half-polarized extended cover (DM260-LENS-16CVR-P) (Risk Group Exempt acc. IEC62471)</li> </ul>	

## Filters

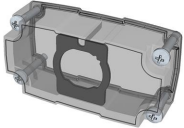
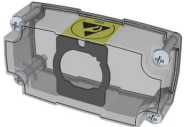

<p>Blue bandpass filter (DM150-BP470)</p>	
<p>Red bandpass filter (DM150-BP635)</p>	

## Lens Covers

Clear lens cover (DM150-CVR-CLR)*	
Clear lens cover, ESD safe (DM150-CVR-ESD)*	
Polarized front cover (DM260-LENS-62CVR-F)*	
Extended lens cover, un-polarized (DM260-LENS-16CVR)**	
Extended lens cover, half-polarized (DM260-LENS-16CVR-P)**	
Extended lens cover, fully polarized (DM260-LENS-16CVR-F)**	
C-mount adaptor, IP40 (DM260-CMNT-00)	
C-mount adaptor, IP65 (DM260-CMNT-CVR)	



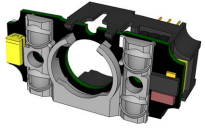



**Note:** \*Use with a 6.2 mm lens only!  
 \*\*Use with a 16 mm lens only! For maximum light power 24VDC supply is recommended.

## Light Options

Red LED illumination (DM150-LED-RED)* Risk Group Exempt acc. IEC62471	
White LED illumination (DM150-LED-WHT)* Risk Group Exempt acc. IEC62471	
Blue LED illumination (DM150-LED-BLU)* Risk Group Exempt acc. IEC62471	
High Powered red LED illumination (DM260-LED-RED-HP)** Risk Group Exempt acc. IEC62471	

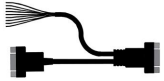
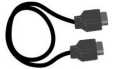
**Note:** \*Use with a 6.2 mm lens only!  
 \*\*Use with a 16 mm lens only!

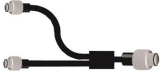

## Cables

Connection cable 24V, I/O, RS-232 (CCBL-05-01) Connection cable 24V, I/O, RS-232 (CCB-M12x12Fy-xx) (y=S: straight / y=A: angled *, xx specifies length)	
Connection cable RS-232 (CCB-M12xDB9Y-05)	
RS-232 & Flying Leads I/O Cable, 2.5 m (DM-RS232IO-00)	
RS-232 adapter cable with power tap (DM100-RS232-000)	
X-Coded to RJ45 Ethernet Cable, 5 m (CCB-84901-2001-xx, where xx can be 02, 05, 10 or 15, indicating length in meters)	
Adapter cable, M12x12 to M8x4/M8x5, 0.5 m (DM260-ADAP-M12M8)	
Adapter cable, ETH, M12, X-CODED/A-CODED, 0.5 m (CCB-M12x8MS-XCAC)	

## Power Supplies

Power supply, 6V (DM100-PWR-000)	
----------------------------------	---

## Mounting Brackets

Mounting bracket	(DM100-UBRK-000)	
Pivot mounting bracket	(DM100-PIVOTM-00)	

## DataMan 260 Systems

	1-D and Stacked Codes	Omni-directional 1-D Code Reading	1DMax™ — Best-In-Class 1-D Reading	IDQuick™ — High-Speed 2-D Reading	2DMax™ — for hard to read DPM and damaged 2-D codes	Resolution
DataMan 260 S		√	√	√		752 x 480 Global shutter
DataMan 260 QL		√	√			752 x 480 Global shutter
DataMan 260 Q		√	√	√		752 x 480 Global shutter
DataMan 260X		√	√	√	√	752 x 480 Global shutter
DataMan 262 S		√	√	√		1280 x 960 Global shutter
DataMan 262 QL		√	√			1280 x 960 Global shutter
DataMan 262 Q		√	√	√		1280 x 960 Global shutter
DataMan 262 X		√	√	√	√	1280 x 960 Global shutter

## Model Variants

S models do not have Burst and Continuous trigger modes.

	260S	260QL	260Q	260X
<b>2-D Codes</b>	Yes	No	Yes	Yes
<b>Algorithm</b>	1DMax, IDQuick, HotBars	1DMax, HotBars II	1DMax, IDQuick, HotBars II	1DMax, 2DMax (Power Grid available), HotBars II
<b>Acquisition</b>	Max 2 fps	Max 60 fps	Max 60 fps	Max 60 fps
<b>Max Decode Rate</b>	2/sec	45/sec	45/sec	45/sec

	262S	262QL	262Q	262X
<b>2-D Codes</b>	Yes	No	Yes	Yes
<b>Algorithm</b>	1DMax, IDQuick, HotBars	1DMax, HotBars II	1DMax, IDQuick, HotBars II	1DMax, 2DMax (Power Grid available), HotBars II
<b>Acquisition</b>	Max 2 fps	Max 45 fps	Max 45 fps	Max 45 fps
<b>Max Decode Rate</b>	2/sec	45/sec	45/sec	45/sec

## Communication Modules

The DataMan 260 is available with the following communication options:

- 24 VDC Ethernet Model
- PoE (Power over Ethernet) Ethernet Model

## Ethernet Interfaces

The DataMan 260 readers provide the following interface modules:

- **24 VDC Ethernet Model/ RS-232:** This module has Ethernet and RS-232 interfaces and requires 24V external power (Non-PoE).
- **PoE Ethernet Model/ RS-232:** This module has Ethernet and RS-232 interfaces and supports Power over Ethernet.



**Note:** Connectors without a cable should be covered by a protective cap to meet the IP requirements.

This I/O module has an M12x8 X-coded connector for the Ethernet signals and a (male) M12x12 connector for power, I/O and RS-232.

The signals on the M12x12 connector are the following:

PIN	Signal: 24 VDC Ethernet Model	Signal: PoE Ethernet Model
1	OUT_2	OUT_2
2	TXD	TXD
3	RXD	RXD
4	OUT_3	OUT_3
5	IN_1	IN_1
6	IN_COM	IN_COM
7	+24V VIN	N.C.
8	GND	RS232GND
9	OUT_COM	OUT_COM
10	IN_0	IN_0
11	OUT_0	OUT_0
12	OUT_1	OUT_1

**Note:** When angled cables are mounted, all of them point downwards or, in the case of the 90° configuration, backwards.

## Reader Layout

The following images show the built-in lighting system and other features of the DataMan 260.

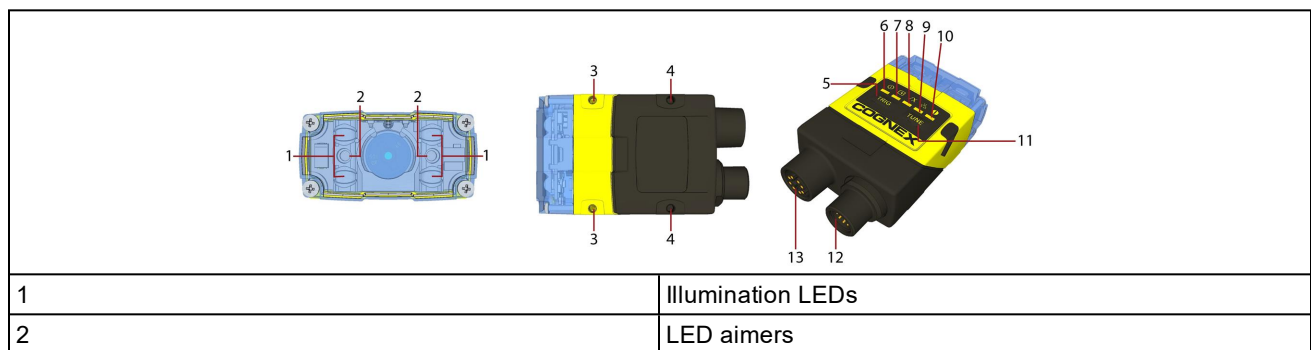

3-4*	Mounting holes (M3 x 3.5mm)
5	Trigger button
6	Power indicator
7	Train status indicator
8	Good/bad read indicator
9	Network status indicator
10	Error indicator
11	Tune button
12	Power, I/O and RS-232 connector
13	Ethernet connector

**Note:** \*Use only one set of mounting holes (either 3 OR 4) for mounting.

**Note:** The five status LEDs together also function as a peak meter using an orange light.

## Indicator LEDs

Type	Signal	Color	Meaning
Status	Power	GREEN	Power ON
	Train status	GREEN	Trained
		YELLOW	Untrained
	Error	RED	Error - check device log
Action	Good/bad read	GREEN	Good read
		RED	Bad read
	Network	YELLOW	Link up
		<i>blink</i>	Data transfer
	Peak meter	Yellow	Tune
			Focus

## Changing Orientation

Perform the following steps to change between in-line and right-angle configuration.

**Note:**

- Switching between in-line and right-angle configuration is recommended only up to 10 times in the lifetime of the DataMan 260.
- Disconnect the DataMan 260 from power before changing the orientation.

**WARNING:** Make sure that no electrostatic charges are applied to the PCB. (e.g. wear ESD shoes.) If the main module is separated from the I/O connector module, take care to assemble them correctly. Otherwise, the IP rating can be compromised.

1. Carefully remove the screw covers, threaded nuts and washers.

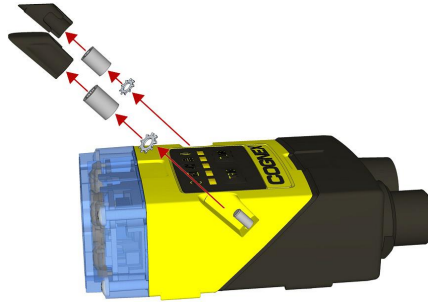

M2 Torx 10 CAP NUT

DIN 6798A M2 LOCKWASHER

2. Detach the main module and the I/O connector module by firmly pulling them apart.

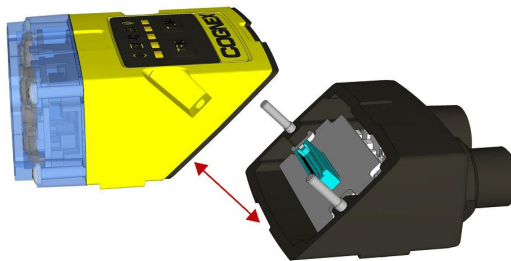

3. Change the orientation.

**Note:** Make sure that the gasket is properly seated on the main module. Ensure that the flat gasket side is facing away from the module.

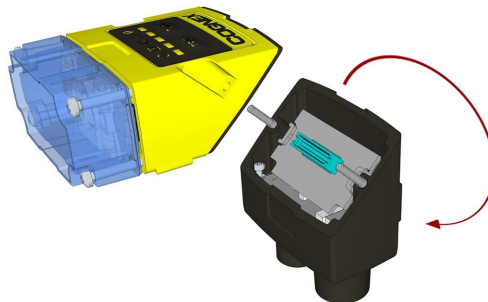

Place the bottom edge of the gasket onto the underside of the main module. Press on the top edge to fully seat the gasket.

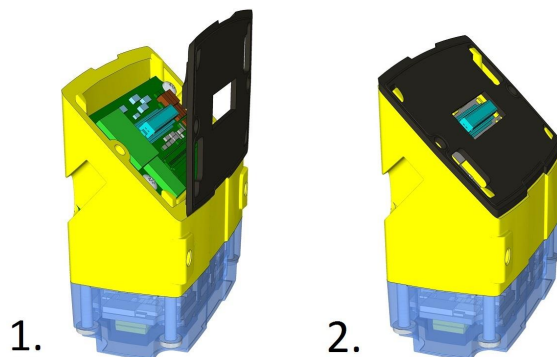

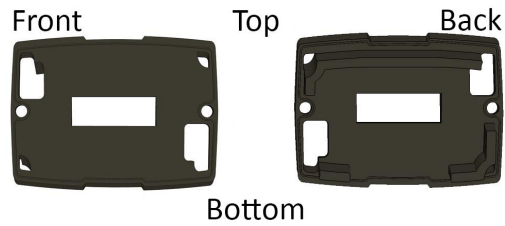

**Note:** The flat side of the gasket (marked as "Front" in the image above) has to face outside.

**WARNING:** Do not touch any electrical component.

- Reattach the I/O connector module to the main module.



- Reinstall the washers and loosely fasten the modules together with the two T10 cap nuts, but do not tighten.

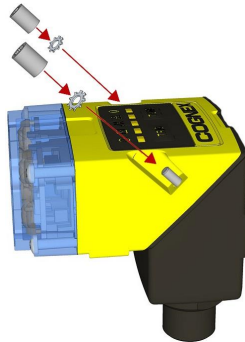

- After each cap nut has been fastened, torque to 0.12 Nm (1.06 in-lb) and reinstall the screw covers.

**Note:** There are unique left and right screw covers. Take care to attach them correctly.

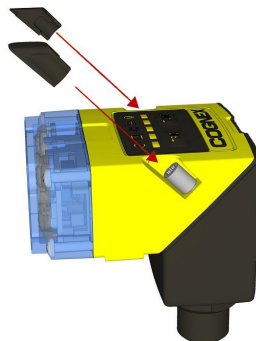

## Dimensions

The DataMan 260 consists of three main parts:

1. Optics module (lens including lens mount, illumination and front cover including filter mounting option for a Diameter ( $\varnothing$ ): 12.3mm< $\varnothing$ <12.7mm, Thickness (t): 1.6mm<t<2mm filter)
2. Main module, including sensor and CPU
3. I/O module

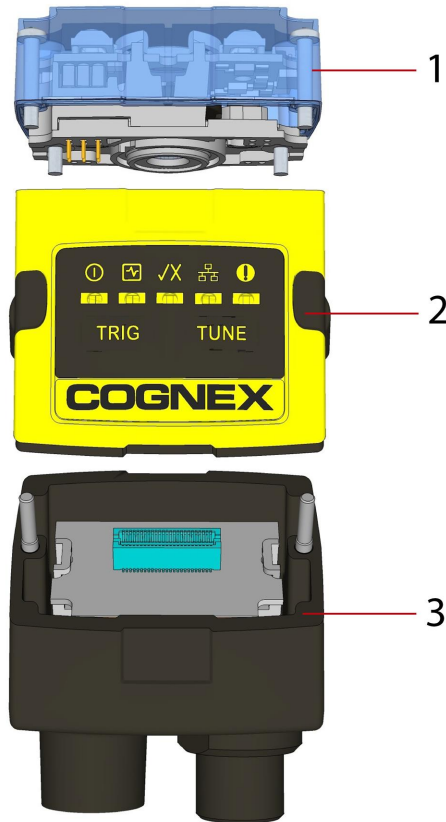

## Dimensional Drawings

The size of the DataMan 260 in the straight configuration is shown in the following figure:

**Note:**



- Dimensions are in millimeters [inches] and are for reference purposes only.
- All specifications are for reference purposes only and can change without notice.

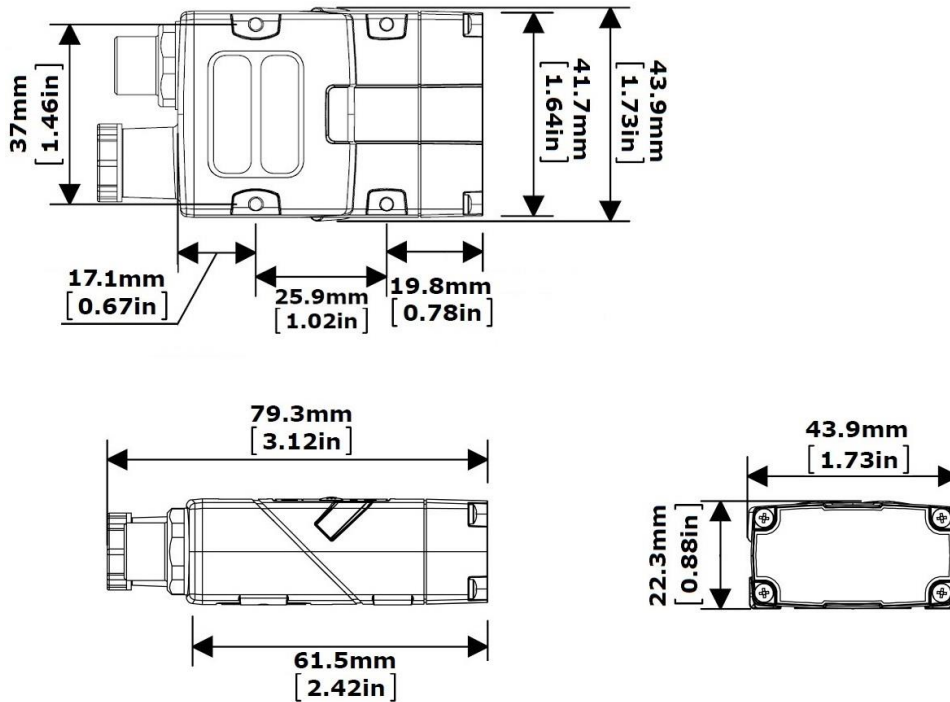

The size of the DataMan 260 in the angled configuration is shown in the following figure:

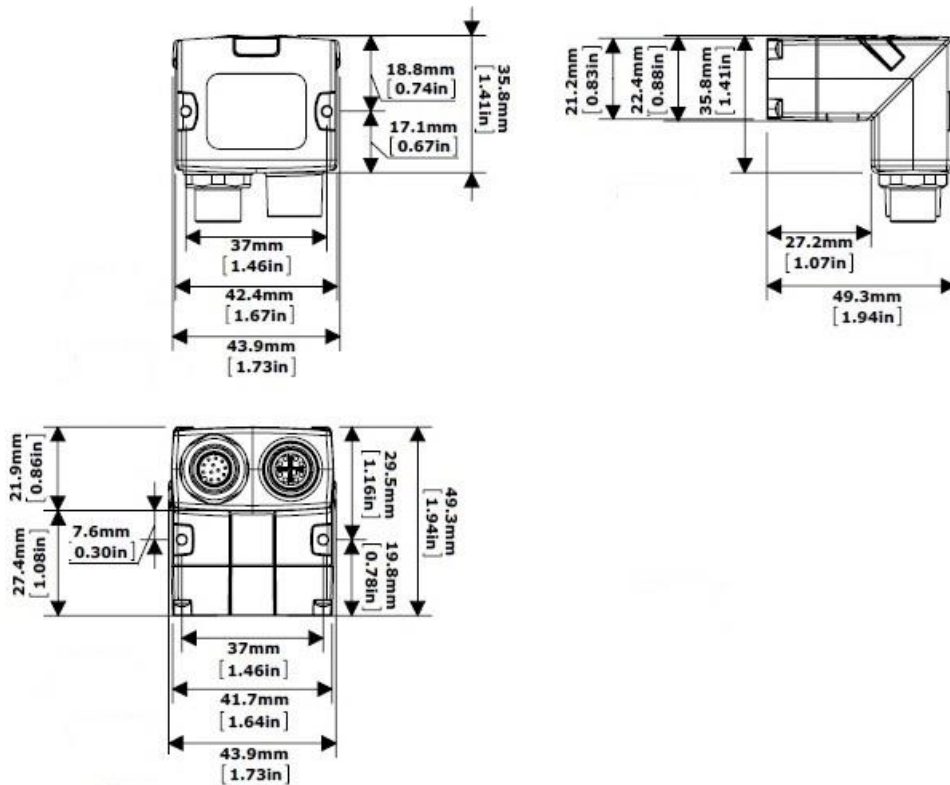

## DataMan 260 Specifications

Weight	142 g
--------	-------

Operating Temperature	0°C — +40°C (+32°F — +104°F)			
Storage Temperature	-10°C — +60°C (+14°F — +140°F)			
Maximum Humidity	<95% (non-condensing)			
Environmental	IP65			
Shock and Vibration	IEC 60068-2-27: 1000 shocks, semi-sinusoidal, 11g, 10ms IEC 60068-2-6: vibration test in each of the three main axis for 2 hours @ 10 Gs (10 to 500 Hz at 100m/s <sup>2</sup> / 15mm)			
LED Safety	IEC 62471: Exempt risk group, no further labeling is required.			
RS-232	RxD, TxD according to TIA/EIA-232-F			
Codes	<b>1-D barcodes:</b> Codabar, Code 39, Code 128, and Code 93, Code 25, Interleaved 2 of 5, Pharma, GS1 DataBar, Postal, Code UPC/EAN/JAN, MSI <b>2-D barcodes:</b> Data Matrix™ (IDMax and IDQuick: ECC 0, 50, 80, 100, 140, and 200) QR Code and microQR Code, RSS/CS, PDF 417, MicroPDF 417, AztecCode, DotCode, MaxiCode			
Discrete I/O operating Limits	HS Output 0, 1, 2, 3	I <sub>MAX</sub>	@ 24 VDC	50 mA
		R <sub>MAX</sub>	@ 12 VDC	150 Ω
			@ 24 VDC	470 Ω
	Input 0 (Trigger)	V <sub>IH</sub>	±15 — ±25 V	
	Input 1	V <sub>IL</sub>	0 — ±5 V	
		I <sub>TYP</sub>	@ 12 VDC	2.0 mA
			@ 24 VDC	4.2 mA
Power Supply Requirements	Options: <ul style="list-style-type: none"> <li>PoE powered: Class 1 PoE supply, maximum 3.84 W</li> <li>External power supply (no PoE): +24 VDC +/- 10% (1 A maximum, 5 W average)</li> </ul> Supplied by LPS or NEC class 2 only			
Power Consumption	<3.84 W (PoE Class 1) <5 W (average, externally powered at +24 V)			
Ethernet Speed	10/100			
Duplex Mode	Full duplex or half duplex			

## DataMan 260 Series Imager Specifications







Specification	DataMan 260 Imager	DataMan 262 Imager
Image Sensor	1/3 inch CMOS	1/3 inch CMOS
Image Sensor Properties	4.51 mm x 2.88 mm (W x H), 6.0 μm square pixels	4.8 mm x 3.6 mm (W x H), 3.75 μm square pixels
Image Resolution (pixels)	752 x 480	1280 x 960
Lens Type	S-mount 6.2 mm F:5 (with optional liquid lens) with IR blocking filter S-mount 16 mm F:7 (with optional liquid lens) with IR blocking filter	

## LED Wavelengths

The following table shows LED types and the related wavelengths:

LED	$\lambda$ [nm]
RED	617
RED HPIL	617
BLUE	470
WHITE	6500K (Color Temperature)
IR	850
IR HPIL	850
UV	365

## Illumination Options

Illumination Board	5V USB Powered		PoE Powered		24V Externally Powered	
	Max. exposure time	Max. duty cycle	Max. exposure time	Max. duty cycle	Max. exposure time	Max. duty cycle
<b>Standard Red</b> 	500 $\mu$ s	3%	500 $\mu$ s	3%	1 ms	6%
<b>High Power Red</b> 	500 $\mu$ s	2%	500 $\mu$ s	3%	10 ms	10%
<b>Standard White</b> 	450 $\mu$ s	3%	450 $\mu$ s	3%	1 ms	6%
<b>Standard Blue</b> 	500 $\mu$ s	3%	500 $\mu$ s	3%	1 ms	6%
<b>IR</b> 	500 $\mu$ s	3%	500 $\mu$ s	3%	1 ms	6%
<b>High Power IR</b> 	500 $\mu$ s	3%	500 $\mu$ s	3%	1 ms	6%

# Setting Up Your DataMan 260

This section provides information on the physical appearance of the DataMan 260 reader. It also details the steps of mounting the reader, installing the lenses and filters of the reader, and gives information on the imager itself.

## Installing an Optical Filter

Perform the following steps to install an optical filter in the optics module of the DataMan 260 reader.

**Note:** Disconnect the DataMan 260 reader from power before installing an optical filter.

Observe the following constraints on the filter:

- Diameter ( $\varnothing$ ):  $12.3\text{mm} < \varnothing < 12.7\text{mm}$
- Thickness (t):  $1.6\text{mm} < t < 2\text{mm}$  filter

1. First, remove the front cover: unscrew the four M2x12mm Phillips Pan head screws and take off the LED cover.

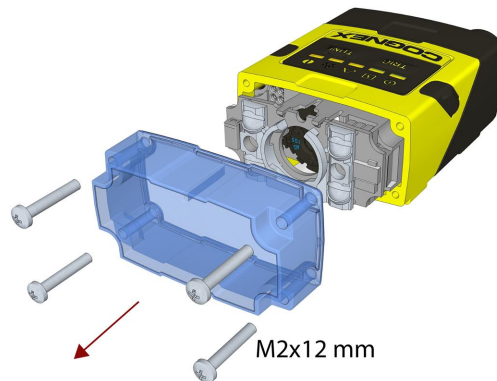

2. Insert the filter at the bottom side of the round opening in the transparent plastic part.

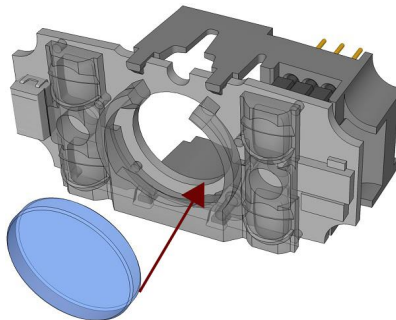

3. Push the top side of the filter firmly until it is sitting flat against the PCB.

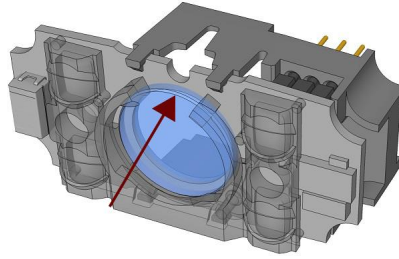

**Note:** Use finger to push the filter in and then a q-tip to clean the filter, or use a q-tip to push the filter into place.

4. Attach the front cover. Observing the tightening sequence below, tighten all four M2x12mm Phillips Pan head screws to 9 Ncm using a torque wrench.

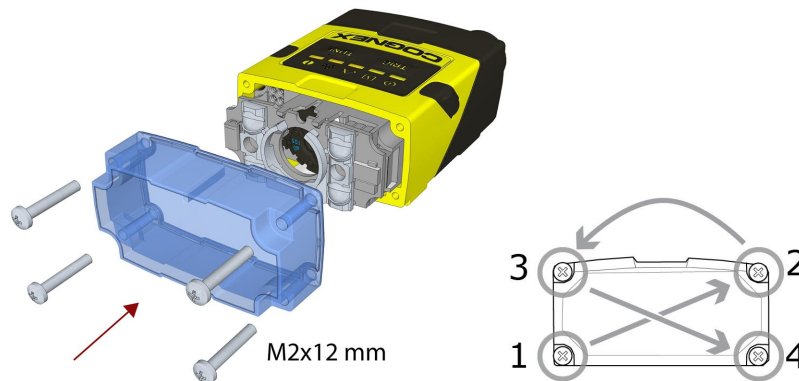

**Note:** The rib in the front cover must be oriented to the top side.

## Installing a Liquid Lens

Perform the following steps to install a liquid lens on your DataMan 260 reader.

**Note:** Disconnect the DataMan 260 reader from power before installing the liquid lens.

1. Remove the front cover: unscrew the four M2x12mm Phillips Pan screws and take off the LED cover.

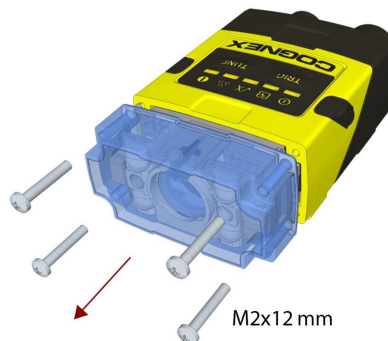

- Remove the illumination module.



- Turn the lens cap to the 105 mm position.

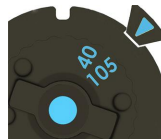

- Remove the lens cap from the imager lens by pulling it.



**Note:** Do not rotate the imager lens while the lens cap is removed. Otherwise, focus calibration will be lost.

- Attach the liquid lens accessory by aligning the 2x2 connectors of the liquid lens with the 2x2 sockets on the optics mount.



- Press the liquid lens onto the imager lens until you reach the stop.



- Reattach the illumination.

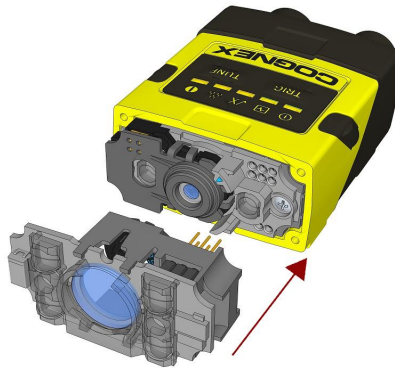

- Attach the front cover. Observing the tightening sequence below, tighten all four M2x12mm Phillips Pan screws to 9 Ncm using a torque wrench.

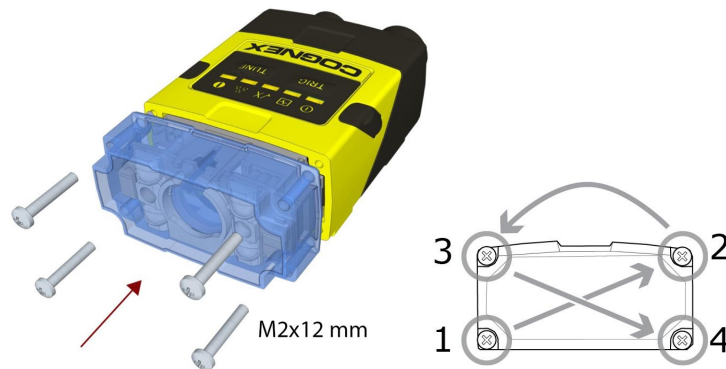

**Note:** The rib in the front cover must be oriented to the top side.

**Note:** The DataMan 260 liquid lens must be calibrated after field exchange. This can be done under **Focus Settings** in the DataMan Setup Tool. For more information, see the *DataMan Questions and Answers* document. **A reboot is required for the lens to operate with the new settings.**

## Changing a 6.2 mm Lens to a 16 mm Lens

Perform the following steps to change a 6.2 mm lens to a 16 mm lens on your DataMan 260 reader.

**Note:** Disconnect the DataMan 260 reader from power before changing lenses.

**WARNING:** This modification must be made in a dust-free and ESD safe area.

1. Remove the front cover: unscrew the four M2x12mm Phillips Pan head screws and take off the LED cover.

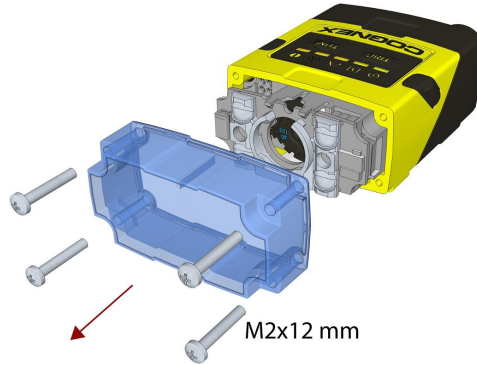

2. Remove the illumination module.



3. Unscrew the two M2x5mm Phillips head screws and remove the 6.2 mm lens mount.

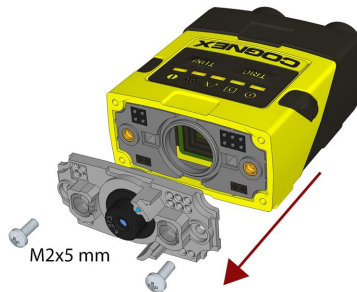

4. Attach the 16 mm lens mount.

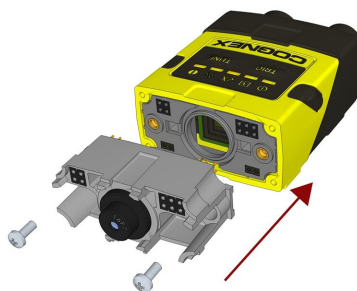

5. Fasten the two M2x5mm Phillips head screws to 0.06 Nm using a torque wrench.

- In the case of a manual focus lens, press the 16 mm lens cap onto the lens. The lens has 12 cutouts so it can be locked in steps of 30 degrees.

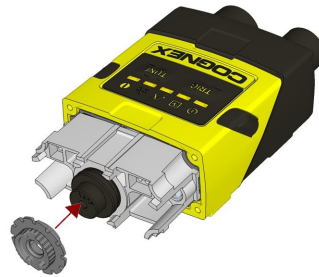

In the case of a liquid lens, mount the liquid lens cap onto the 16 mm lens. (See [Installing a Liquid Lens on page 21.](#))

- Attach the illumination board.

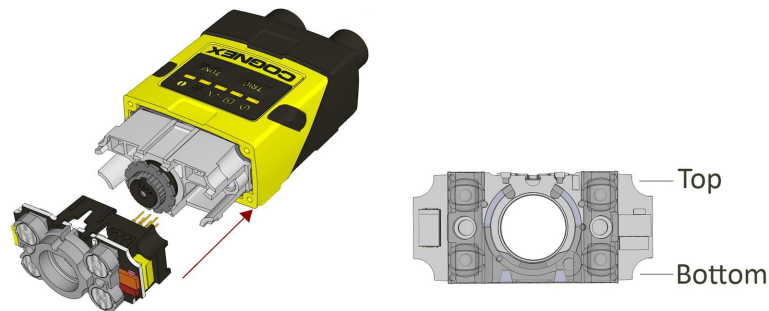

**Note:** Take care to attach the illumination with the right orientation.

- Attach the front cover. Observing the tightening sequence below, tighten all four M2x25 Phillips Pan head screws to 9 Ncm using a torque wrench.

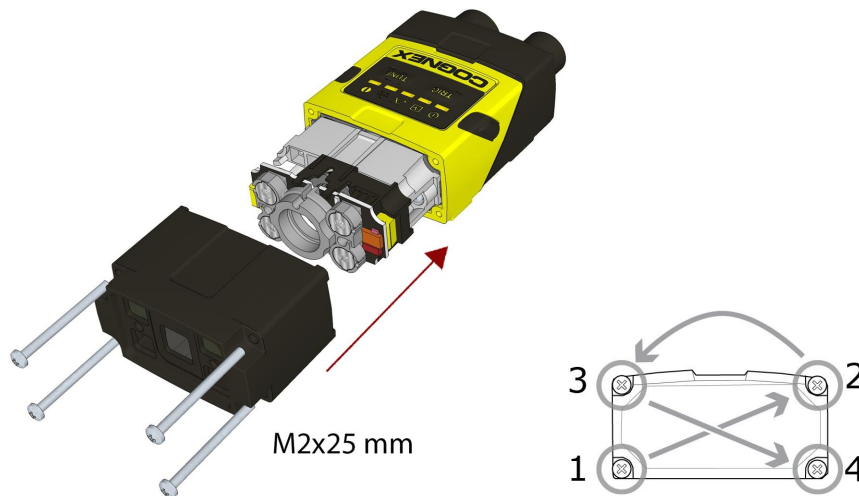

**Note:** The rib in the front cover must be oriented to the top side.

## Changing to an Illumination with a Different Color

Perform the following steps to change the illumination.

**Note:** Disconnect the DataMan 260 reader from power before changing to an illumination with a different color.

1. Remove the front cover: unscrew the four screws and take off the LED cover.

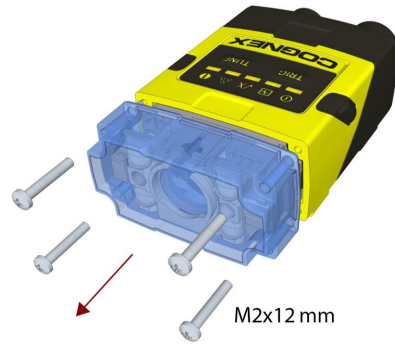

2. Remove the illumination module.

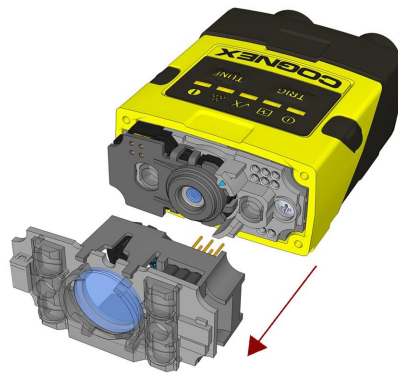

3. Attach a new color illumination module.

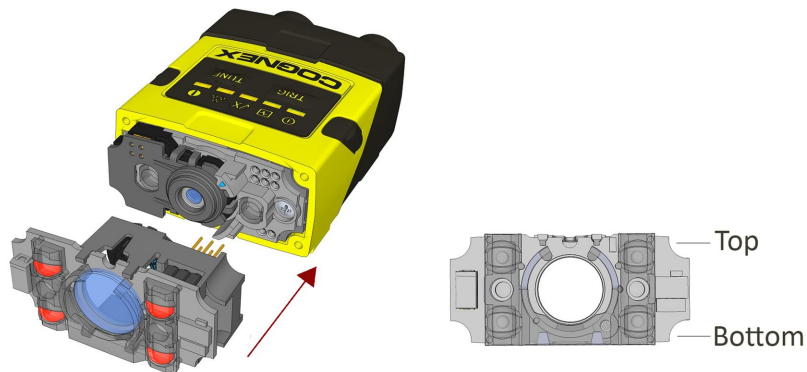

**Note:** Take care to attach the illumination with the right orientation.

- Attach the front cover. Observing the tightening sequence below, tighten all four screws to 9 Ncm using a torque wrench.

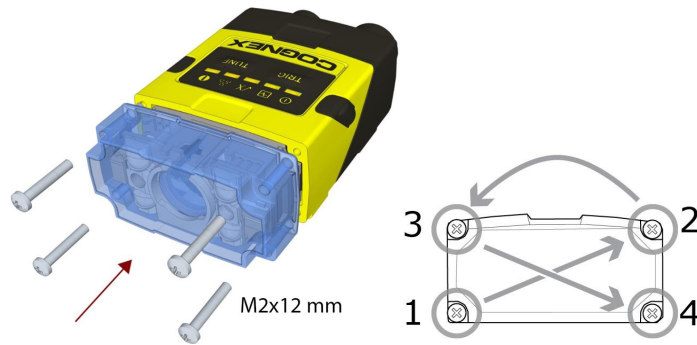

**Note:** The rib in the front cover must be oriented to the top side.

## Mounting

Mounting the DataMan 260 at a slight angle (15°) can reduce reflections and improve reader performance.



## Right-Angle Configuration



## Field of View and Reading Distances

### DataMan 260 Readers with a 6.2 mm Lens

#### Short Range (Focused to 105 mm)

The following tables show the Field of View (FoV) widths of the 6.2 mm lens focused to 105 mm at various distances.

DM260

Distances in mm	2D min. code	1D min. code
40	4 MIL	2 MIL
65	5 MIL	3 MIL
105	10 MIL	6 MIL

DM262

Distances in mm	2D min. code	1D min. code
40	3 MIL	2 MIL
65	4 MIL	2 MIL
105	7 MIL	5 MIL

The following map shows the FoV of the DataMan 260 series readers with a 6.2 mm lens. The horizontal and vertical field of view is shown for working distances of 40 mm, 65 mm and 105 mm.

The FoV values are shown as follows:

- outer: DM262
- inner: DM260

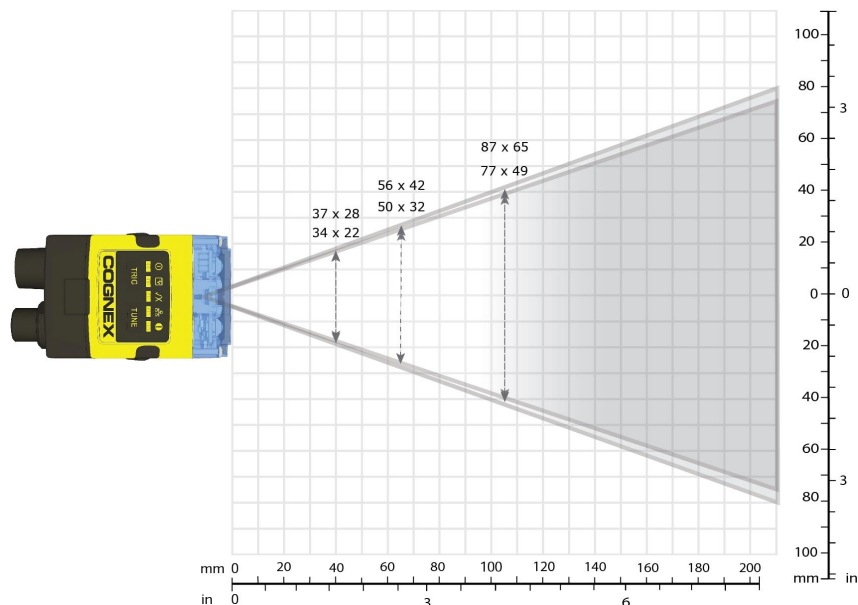

#### Long Range (Focused to 190 mm)

The following tables show the FoV widths of the 6.2 mm lens focused to 190 mm at various distances.

DM260

Distances in mm	2D min. code	1D min. code
150	12 MIL	6 MIL
190	15 MIL	10 MIL
225	18 MIL	10 MIL
375	30 MIL	15 MIL
500	35 MIL	20 MIL
1 m	-	35 MIL

DM262

Distances in mm	2D min. code	1D min. code
150	10 MIL	5 MIL
190	12 MIL	6 MIL
225	15 MIL	6 MIL
375	20 MIL	10 MIL
500	25 MIL	15 MIL
1 m	-	30 MIL

The following map shows the FoV of the DataMan 260 series readers with a 6.2 mm lens. The horizontal and vertical field of view is shown for working distances of 150 mm, 190 mm, 225 mm, 375 mm and 500 mm.

The FoV values are shown as follows:

- outer: DM262
- inner: DM260

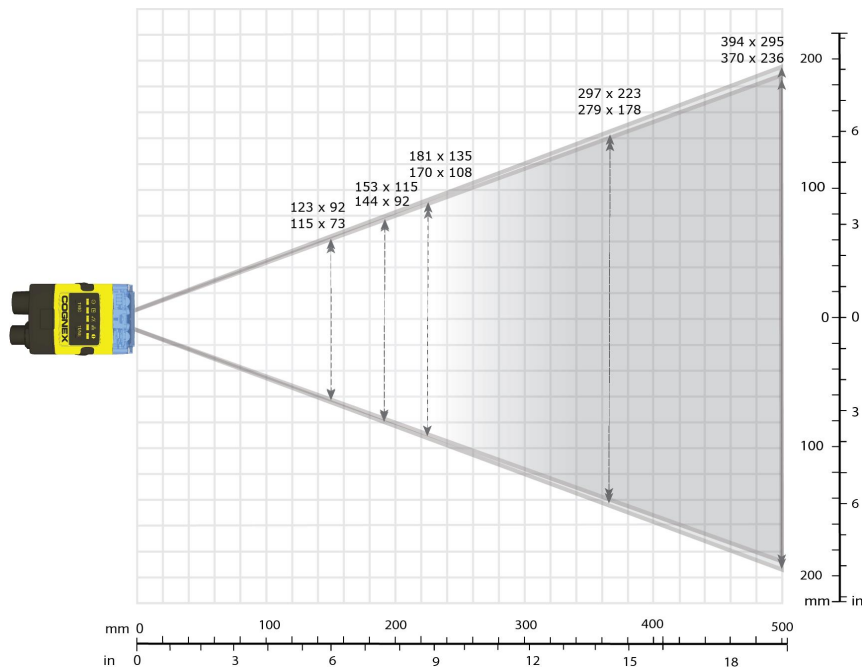

### DataMan 260 Readers with a 16 mm Lens

The following tables show the FoV widths of the 16 mm lens at various distances.

DM260

Distances in mm	2D min. code	1D min. code
80	3 MIL	2 MIL
150	5 MIL	3 MIL
190	6 MIL	4 MIL
225	7 MIL	4 MIL
375	12 MIL	5 MIL
500	15 MIL	10 MIL
1 m	25 MIL	15 MIL

DM262

Distances in mm	2D min. code	1D min. code
80	2 MIL	2 MIL
150	3 MIL	2 MIL
190	4 MIL	2 MIL
225	4 MIL	3 MIL
375	7 MIL	4 MIL
500	10 MIL	6 MIL
1 m	20 MIL	15 MIL

The following map shows the FoV of the DataMan 260 readers with a 16 mm lens. The horizontal and vertical field of view is shown for working distances of 80 mm, 150 mm, 190 mm, 225 mm, 375 mm, 500 mm and 1000 mm.

The FoV values are shown as follows:

- outer: DM262
- inner: DM260

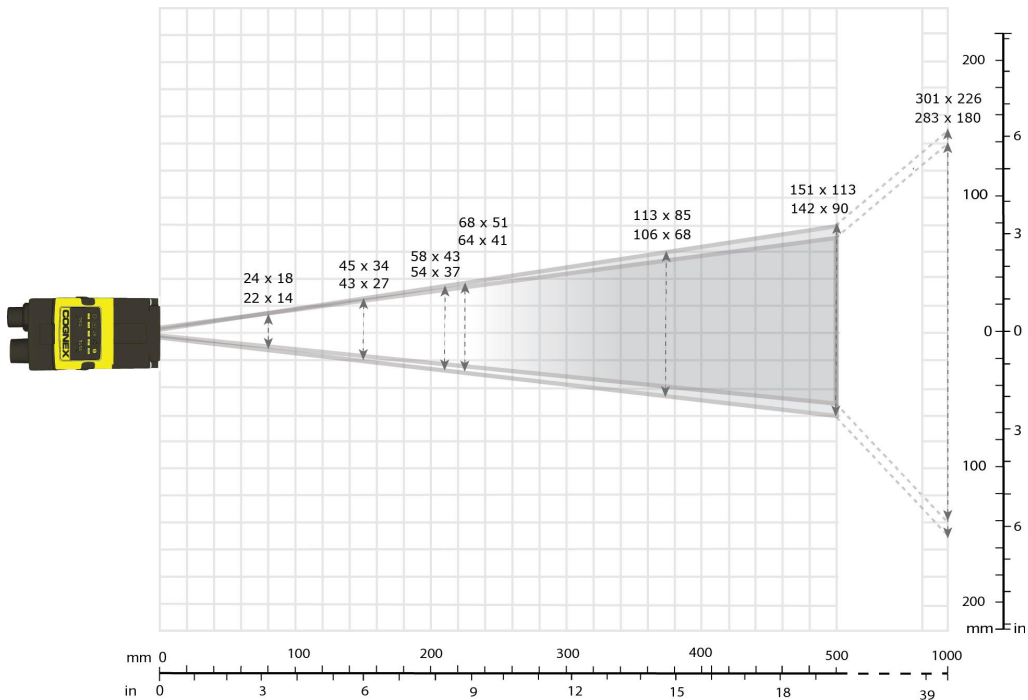

## Connections, Optics and Lighting

Descriptions about the I/O Cables, RS-232 cable, Ethernet cable, and high-speed output lines and wiring are provided in the following sections.

### 5m I/O Breakout Cable (CCBL-05-01)

The I/O cable provides access to trigger and high-speed outputs. You can clip unused wires short or use a tie made of non-conductive material to tie them back.

For RS-232, use the Power Supply return path for ground.

The drawing on the left shows the plug on the device.

#### Signal: 24 VDC Ethernet Model

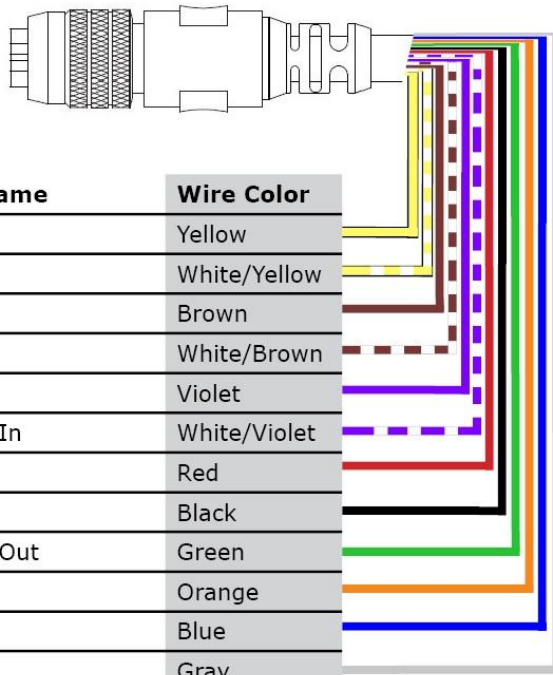

## Signal: PoE Ethernet Model

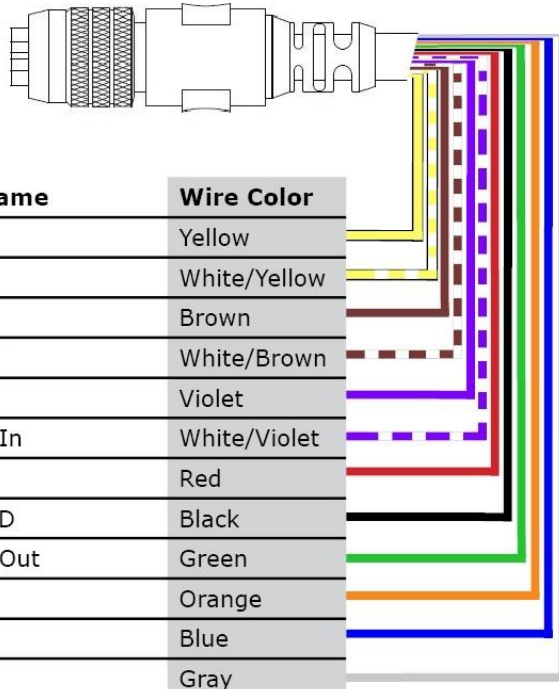

## 5m I/O Breakout Cable (CCB-M12x12Fy-xx)

The I/O cable provides access to trigger and high-speed outputs. You can clip unused wires short or use a tie made of non-conductive material to tie them back.

For RS-232, use the Power Supply return path for ground.

The drawing on the left shows the plug on the device.

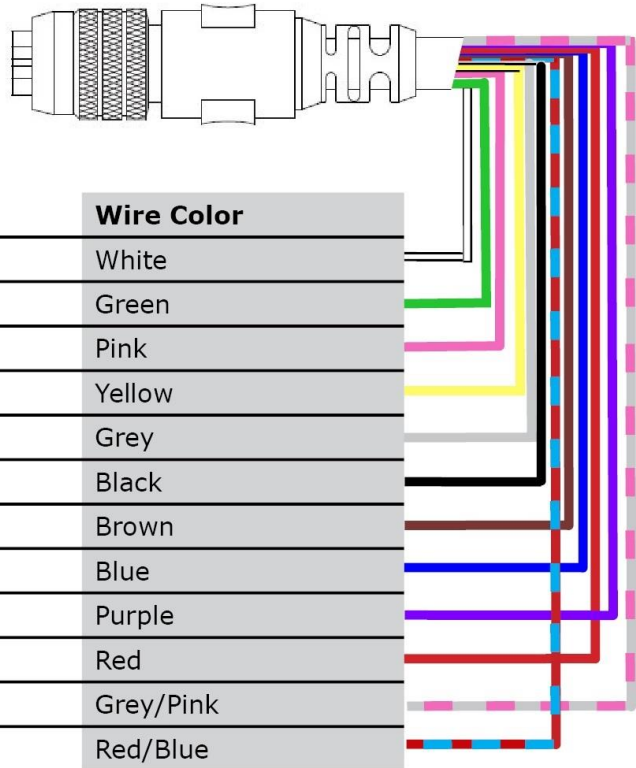

Pin #	Signal Name	Wire Color
1	Out 2/In 2	White
2	TxD	Green
3	RxD	Pink
4	Out 3/In 3	Yellow
5	In 1	Grey
6	Common In	Black
7	+24 VDC	Brown
8	GND	Blue
9	Common Out	Purple
10	In 0	Red
11	Out 0	Grey/Pink
12	Out 1	Red/Blue

### 15m I/O Breakout Cable (CCB-PWRIO-15)

The I/O cable provides access to trigger and high-speed outputs. The cable is not terminated. You can clip unused wires short or use a tie made of non-conductive material to tie them back. For RS-232, use the Power Supply return path for ground.

The drawing on the left shows the plug on the device.

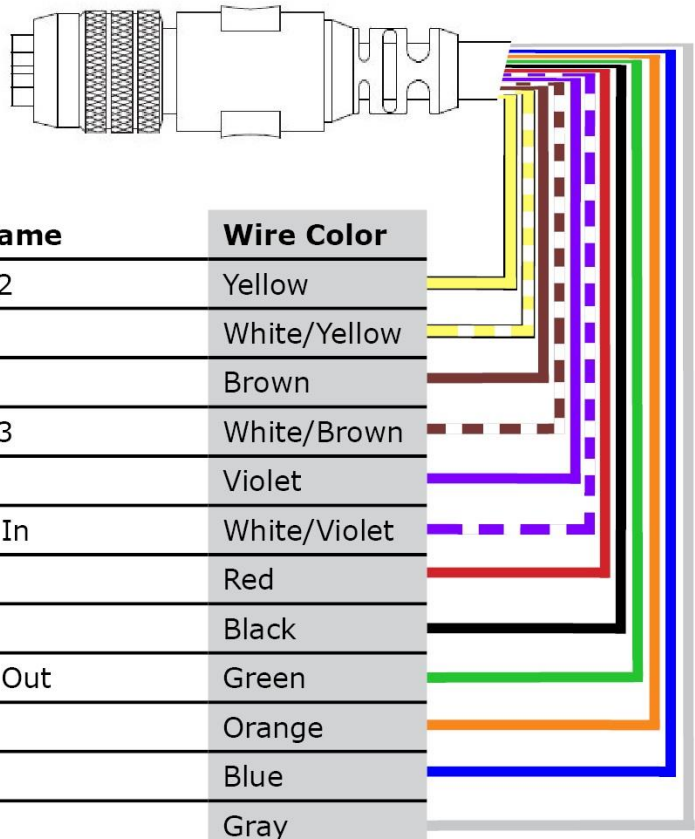

Pin #	Signal Name	Wire Color
1	Out 2/In 2	Yellow
2	TxD	White/Yellow
3	RxD	Brown
4	Out 3/In 3	White/Brown
5	In 1	Violet
6	Common In	White/Violet
7	+24 VDC	Red
8	GND	Black
9	Common Out	Green
10	In 0	Orange
11	Out 0	Blue
12	Out 1	Gray

## Acquisition Triggering

The acquisition trigger input on the reader is opto-isolated.

To trigger from an NPN (pull-down) type photo-detector or PLC output, connect Common In to +24VDC and connect In 0 to the output of the detector. When the output turns on, it pulls Common In down to 0VDC, turning the opto-coupler on.

To trigger from a PNP (pull-up) type photo-detector or PLC output, connect In 0 to the output of the detector and connect Common In to 0VDC. When the output turns on, it pulls In 0 up to 24VDC, turning the opto-coupler on.

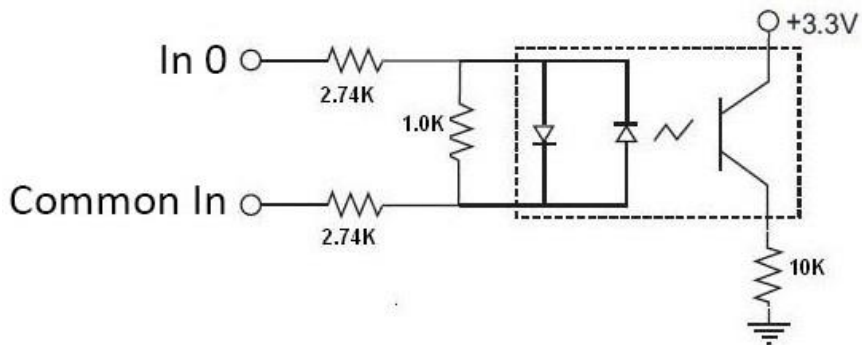

28V Max. Across input pins - Transition approx. 12V (Min).

## High Speed Output Lines

The high-speed outputs can be used as either NPN (pull-down) or PNP (pull-up) lines.

Specification	Description
Voltage	28VDC maximum through external load
Current	50mA maximum ON sink or source OFF state leakage current 100µA External load resistance 240 Ohms to 10K Ohms Each line rated at a maximum 50mA, protected against over-current, short circuits and transients from switching inductive loads. High current inductive loads require external protection diode.

For NPN lines, the external load should be connected between the output and the positive supply voltage (<28VDC). The outputs pull down to less than 3VDC when ON, which causes current to flow through the load. When the outputs are OFF, no current flows through the load.

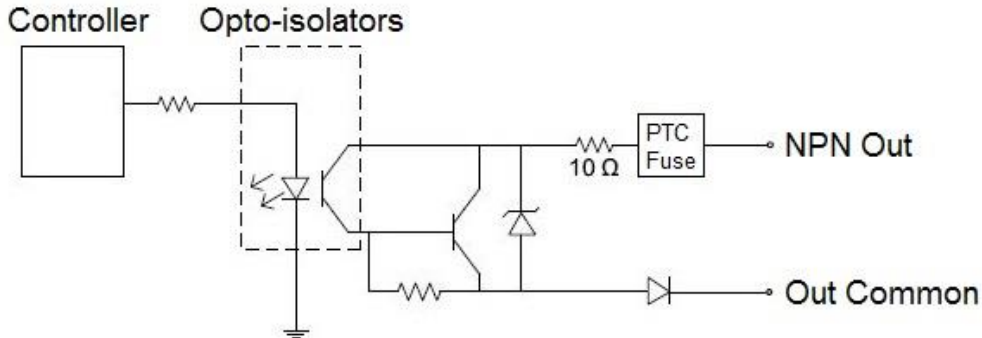

For PNP lines, the external load should be connected between the output and the negative supply voltage (0VDC). When connected to a 24VDC power supply, the outputs pull up greater than 21VDC when ON, and current flows through the load. When the outputs are OFF, no current flows through the load.

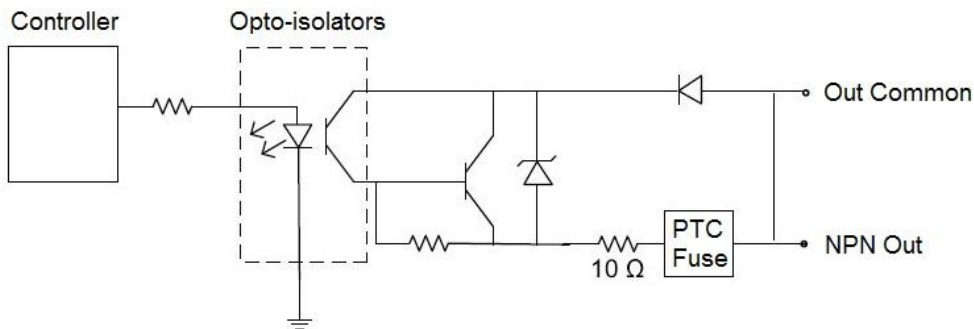

## High-Speed Output Wiring

**Note:** For more information, refer to Breakout Cable Specifications on page 1

To connect to an NPN-compatible PLC input, connect Output 0, Output 1, Output 2 or Output 3 directly to the PLC input. When enabled, the output pulls the PLC input down to less than 3VDC.

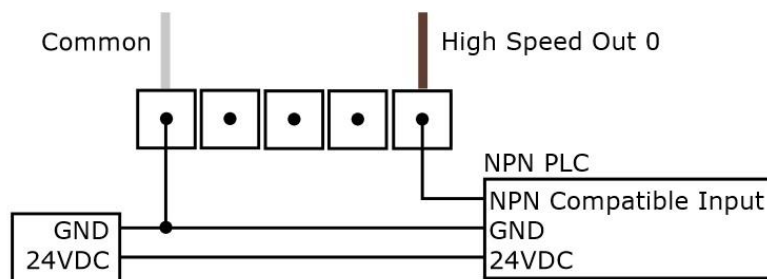

To connect to a PNP-compatible PLC input, connect Output 0, Output 1, Output 2 or Output 3 directly to the PLC input. When enabled, the output pulls the PLC input up to greater than 21VDC.

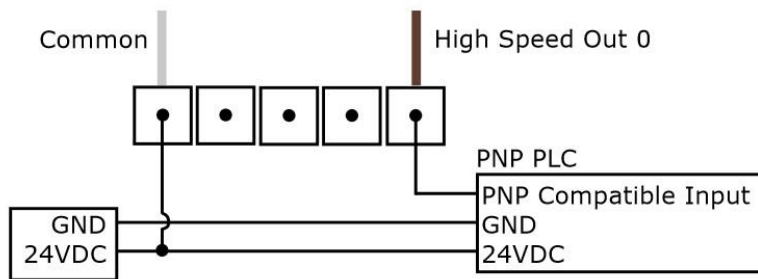

To connect the high-speed outputs to a relay, LED or similar load, connect the negative side of the load to the output and the positive side to +24VDC. When the output switches on, the negative side of the load is pulled down to less than 3VDC, and 24VDC appears across the load. Use a protection diode for a large inductive load, with the anode connected to the output and the cathode connected to +24VDC.

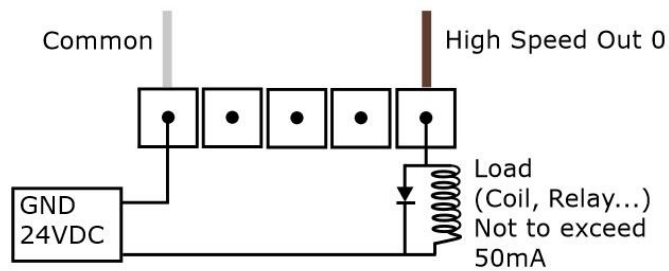

## 5m RS-232 Connection Cable (CCB-M12XDB9Y-05)

You can clip unused wires short or use a tie made of non-conductive material to tie them back.

The figure on the left shows the plug on the device.

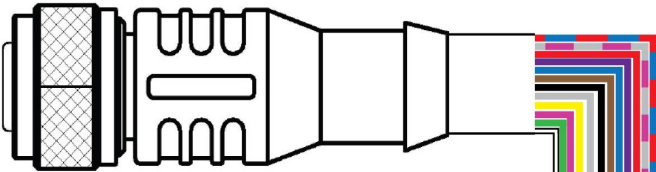

Pin #	Signal Name	Wire Color
1	Out 2	White
2	TxD	Green
3	RxD	Pink
4	Out 3	Yellow
5	In 1	Grey
6	Common In	Black
7	+24 VDC	Brown
8	GND	Blue
9	Common Out	Violet
10	In 0	Red
11	Out 0	Grey/Pink
12	Out 1	Red/Blue

### Ethernet Cables

The Ethernet cable (CCB-84901-2001-05) provides Ethernet connection for network communications. The Ethernet cable can be connected to a single device or provide connections to multiple devices via a network switch or router.

#### M12 X-coded to RJ-45 Cable

P1

P2

P1 Pin Number	Wire Color	Signal Name	P2 Pin Number
1	White/Orange	TxRx A +	1

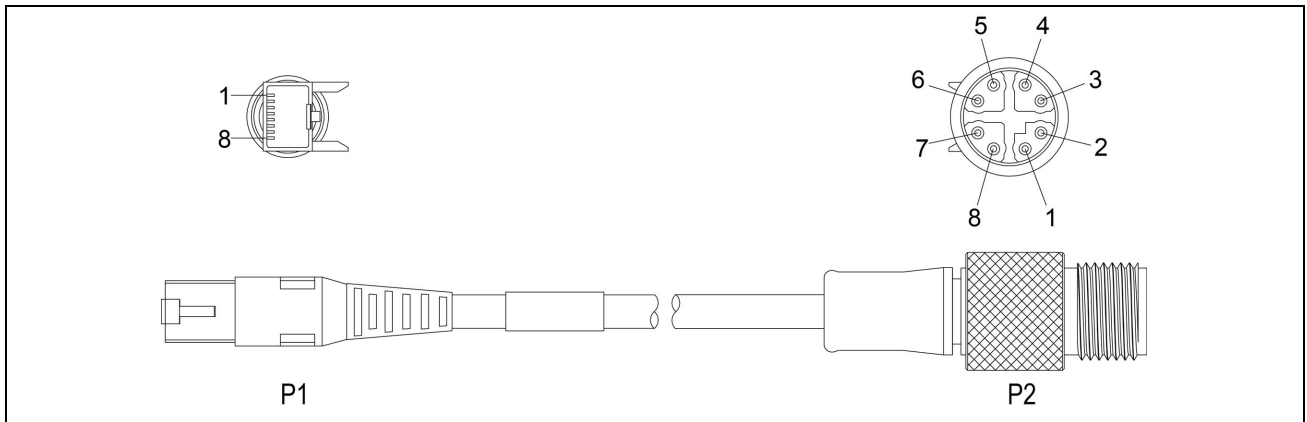

P1 Pin Number	Wire Color	Signal Name	P2 Pin Number
2	Orange	TxRx A -	2
3	White/Green	TxRx B +	3
4	Blue	TxRx C +	8
5	White/Blue	TxRx C -	7
6	Green	TxRx B -	4
7	White/Brown	TxRx D +	5
8	Brown	TxRx D -	6

**Note:** Cables are sold separately. The wiring for this cable follows standard industrial Ethernet M12 specifications. It differs from the 568B standard.

## Multi-port Connections

You can connect multiple DataMan 260 readers to a single PC (or other device equipped with a serial port) using a multi-port connection.

A multi-port connection creates a daisy-chain of readers. Each reader receives serial data from the previous reader and transmits it to the next reader. When a reader transmits data, it is passed through each of the readers in the chain between it and the PC.

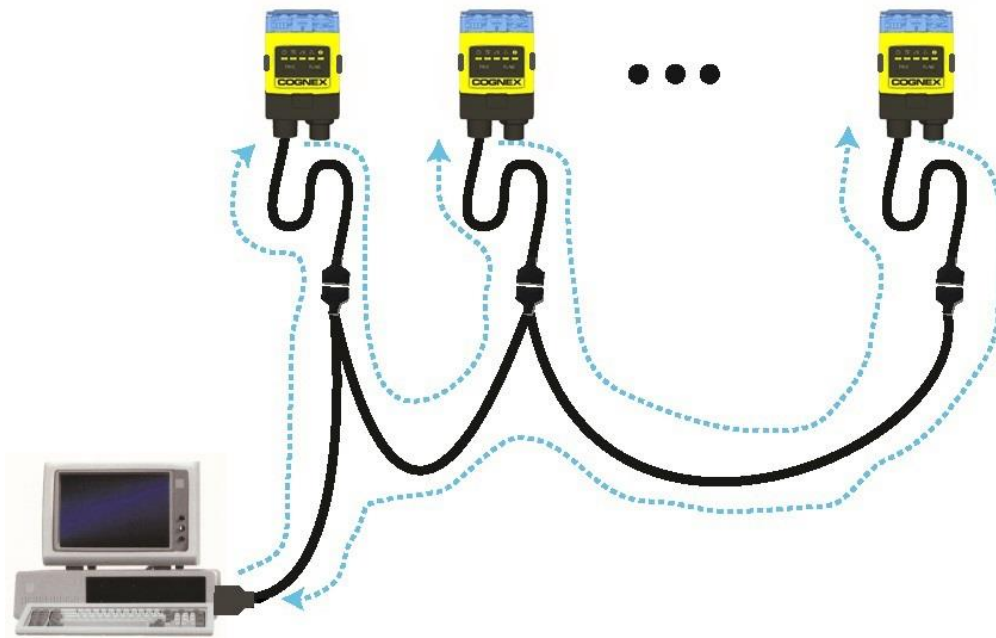

You must construct your own cable that meets the requirements of your system configuration.

The cable must provide a DB-15 connector for each DataMan 260 and a DB-9 connector for the PC serial port. Each DB-15 connector must provide Tx Data, Rx Data, Trigger (Input 0), ground, and DC power. The Tx Data and Rx Data pins on adjacent connectors must be connected to provide the multi-port connection.

The following diagram shows how to create a multi-port cable for a 3-reader system. In the example, all the readers share a common trigger. It is also possible to wire individual triggers for each reader.

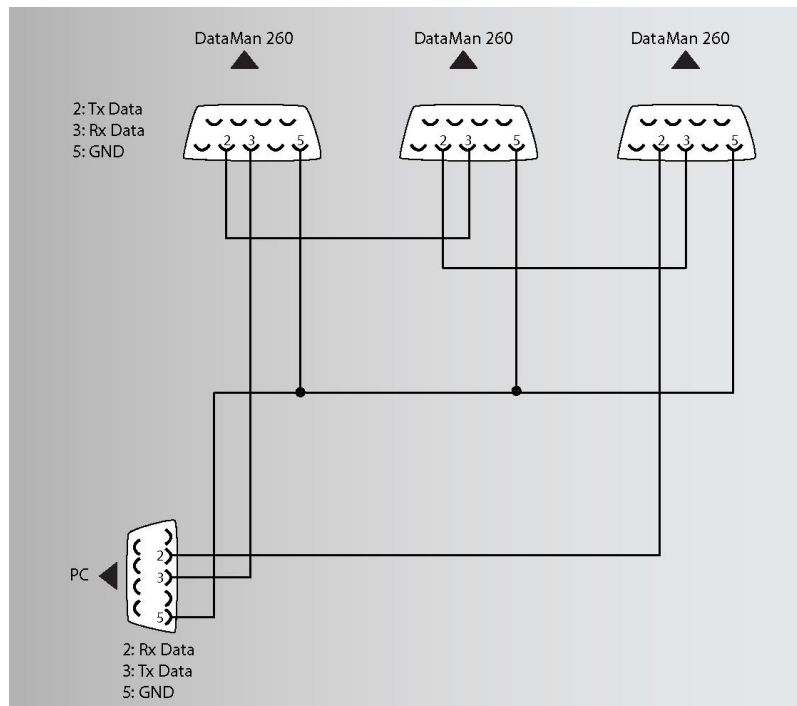

You must connect each DataMan 260 to DataMan Setup Tool using a USB connection and set the DataMan for multi-port operation. To configure a DataMan 260 for multi-port operation, click on the **Enable Multi-Port (RS-232 Sharing)** check box in **Communication Settings**.

There is no guaranteed delivery order when multiple readers transmit data using a multi-port connection; read results may arrive at the PC in any order. You can configure each DataMan 260 reader in a multi-port connection to add identifying data to each read result. Your PC application can then determine which reader produced a specific read result.

To do this, check the **Standard Formatting Enabled** box (for each symbology that you are using) in **Data Formatting**, and enter text in the **Leading Text** field. (You can also add trailing text by entering text in the **Trailing Text** field.)

You can obtain the best results when using multi-port connections by keeping the following usage guidelines in mind as you design your system:

- The maximum cable length between any two DataMan 260 readers or between the PC and any DataMan reader should be no greater than 15 meters.
- There is no fixed limit to the number of DataMan 260 readers that you can connect to a single PC. Each reader introduces a delay of about 100 ms when it retransmits received serial data. If you have 5 readers, this means that there will be a 400 ms delay between the time the first reader in the chain transmits data and the PC receives it.
- Each DataMan 260 reader must receive a hardware trigger signal on its Input 0 line. You can wire the input ports to a common trigger signal or you can provide individual triggers for each reader.
- Each DataMan 260 reader must be individually configured for multi-port operation, and you must perform this configuration using a USB connection.
- If *any* reader in the multi-port chain loses power or becomes disconnected, then no data from any other reader will be transmitted.
- If a DataMan 260 is transmitting its own read result, it will buffer any data received from another reader until it has finished its own data transmission. If a DataMan 260 is transmitting another reader's data, it will buffer its own data if it receives a trigger signal while it is processing the other reader's data.
- If you use a single power supply for multiple readers, make sure that the power supply can provide enough power for all of the readers.

# Using Your DataMan 260

This section provides general information about the installation process of the DataMan Setup Tool, triggering, and reader training.

## Installing the DataMan Software

Perform the following steps to install the DataMan Setup Tool:

1. Check the **DataMan Release Notes** for a full list of system requirements.
2. Download the DataMan Setup Tool from <http://www.cognex.com/support/dataman> and follow the on-screen steps.
3. Connect the DataMan 260 to your PC.
4. Choose **Start > Programs > Cognex > DataMan Software vx.x.x > Setup Tool** to launch the DataMan Setup Tool. Detected readers will appear under **COM ports**.
5. Click **Refresh** to update the list of connected devices.
6. Select the device from the Network list (**Discovered Devices**) and click **Connect**.

## Industrial Protocols

The DataMan 260 readers support the following industrial protocols:

- EtherNet/IP™
- PROFINET
- Modbus TCP
- SLMP

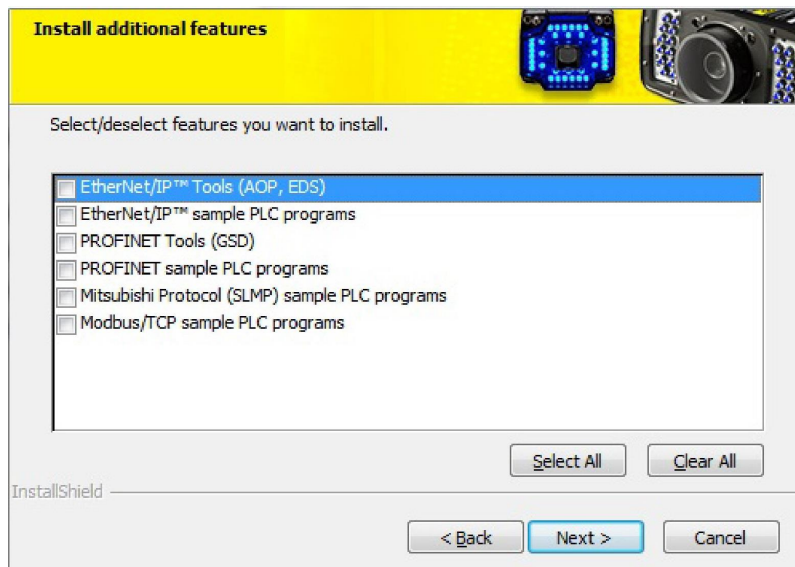

Select industrial protocol samples and tools you want to use when you install the DataMan Software. There are three ways to enable or disable Industrial Protocols. Using either method, a reboot is required for the changes to take effect.

1. Enable the protocols using the Industrial Protocols pane of the DataMan Setup Tool (under Communication Settings).
2. Scan the appropriate Reader Configuration codes (see **Reader Configuration Codes** available through the Windows **Start** menu or the DataMan Setup Tool **Help** menu).
3. Send the appropriate DMCC (see **Command Reference** available through the Windows **Start** menu or the DataMan Setup Tool **Help** menu).

For more information on using the industrial protocols, see the **DataMan Industrial Protocols Manual** available through the Windows **Start** menu or the DataMan Setup Tool **Help** menu.

## Setting the Focus Position

DataMan 260 can operate in one of three distance ranges. Follow the steps below to set the focus position.

1. Remove the screws and the front cover.

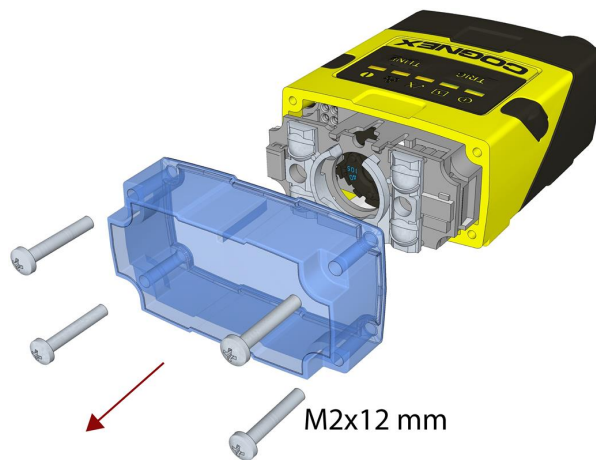

2. Using a flathead screwdriver, set the focus position from the front. Always turn clockwise to focus to a larger distance and counterclockwise to focus to a shorter distance.

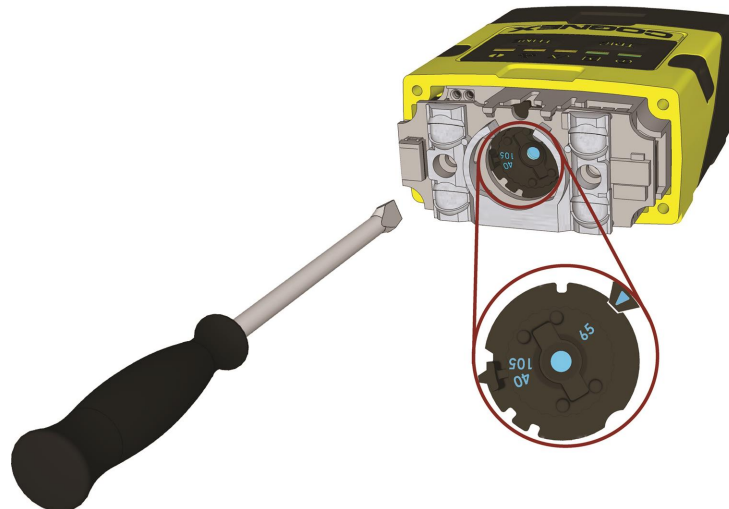

**Note:** If an optical filter has been mounted, first disconnect the DataMan 260 reader from power and remove the illumination module with the filter before adjusting the focus.

3. Remount the front cover. Observing the tightening sequence below, tighten all four screws to 9 Ncm using a torque wrench.

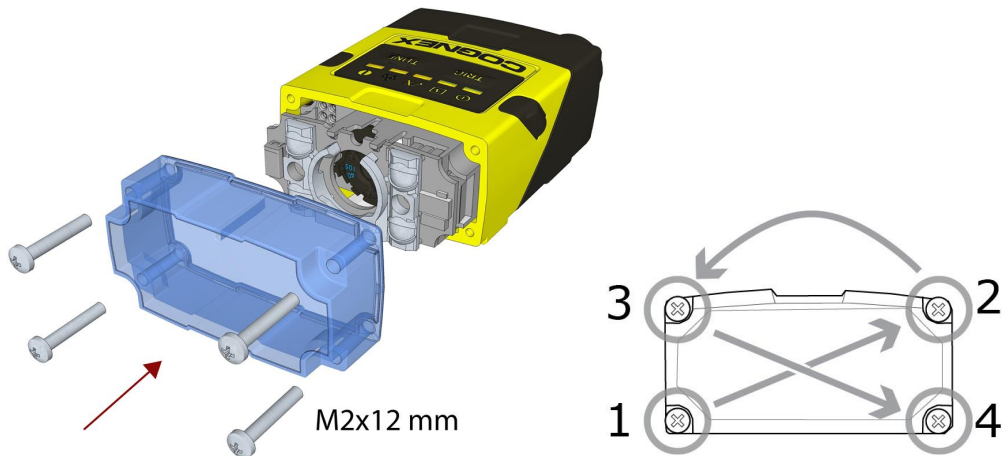

**Note:** If you use an optical filter and the illumination was removed, remount the illumination module first and then remount the front cover.

**Note:** The rib in the front cover must be oriented to the top side.

## Tuning

By tuning, your DataMan 260 reader automatically selects the best settings for the given reading situation, based on parameters of illumination, camera and decoder properties, and focal distance. Tuning autodiscriminates all enabled symbologies (both 1-D and 2-D). If multiple symbols are found in the field of view, tuning locks on the first one found. Use this feature to create an optimum setting to read your codes.

You can use any of the following methods to tune your reader:

Press the Tune button (  ) at least for 3 seconds on your reader. The first press starts the tuning and the second press cancels the tuning, if it is still ongoing.



Turn on tuning in DataMan Setup Tool (  ).

Start tuning by sending a DMCC, for more information, see the **Command Reference**, available through the Windows **Start** menu or the DataManSetup Tool **Help** menu.

Use Input line 1 for tuning. Go to the **System Settings** pane in the DataManSetup Tool and check **Tune**. You can also use the **In1** button on the toolbar.

**Note:** Tune button can toggle the aimer light ON and OFF.

## External Triggering and Trigger Modes

If you are using external triggering, you can use any of the following methods to trigger your DataMan 260 reader:

1. Press the Trigger button (  ) on the reader.
2. Send a pulse on the I/O cable: Trigger + (orange or red), Trigger - (black).

- Send a serial trigger command over the RS-232 or the Ethernet connection.
- Click the Trigger button (  ) or press <Ctrl>-T in DataMan Setup Tool.

DataMan 260 supports a variety of trigger modes:

- Single:** Acquires a single image and attempts to decode any symbol it contains or more than one symbol in cases where multicode is enabled. The reader relies on an external trigger source.
- Presentation:** Repeatedly scans for a symbol and decodes it whenever one is detected. The reader relies on an internal timing mechanism to acquire images.
- Manual (default):** Begins acquiring images when you press the trigger button on the reader or the discrete trigger input is activated, and continues acquiring images until a symbol is found and decoded or you release the button or the discrete trigger input is deactivated.
- Burst:** Performs multiple image acquisitions based on an external trigger and decodes one or multiple symbols appearing in the sequence of images.
- Self:** Similar to *Presentation* mode in that the reader perpetually scans for symbols and decodes them each time one is detected. Unlike *Presentation* mode, however, *Self* mode supports multicode results and a decode attempt occurs with every image. The main difference between *Self* and *Presentation* is the fixed and exact interval for image acquisitions in *Self*.
- Continuous:** Begins acquiring images based on a single external trigger and continues to acquire images until a symbol is found and decoded, or until multiple images containing as many codes as specified in multicode mode are located, or until the trigger is released.

S models do not have Burst and Continuous trigger types.



## Training and Trigger Modes

Training is supported for the following trigger modes:

- Single trigger
- Burst mode
- Self trigger
- Continuous mode

### Training

Training your reader with the expected symbology may help increase decode yield. To train your reader, place a code in front of the reader and do one of the following:

- Press and hold the trigger button (  ) for at least 3 seconds and then release it.
- Click and hold the trigger button in the DataMan Setup Tool (  ) for at least 3 seconds and then release it.
- Click **Train Code** in the **Action** ribbon of the DataMan Setup Tool.

If using Single trigger mode, upload the code through **File** -> **Train Image**.

**Note:** You can use training in *Single*, *Burst*, *Continuous* or *Self* trigger modes. Only a single symbol of each kind of symbology can be trained per read setup.

DataMan 260 reports the status of the training and brightness optimization operations using its signaling LEDs. The

second LED from left on the reader flashes green to indicate that the reader is currently trained, or yellow to indicate that it is not trained.



Connect the reader to the DataMan Setup Tool to untrain it and allow it to recognize other enabled symbologies.

## Incremental Training for Multiple Symbologies

If you want to train the reader to recognize multiple symbologies, you can present a single image showing all the desired symbologies and perform the training procedure described in the previous section.

If you cannot present a single image showing all the necessary symbologies, you can enable incremental training on the **Training** tab of the **Symbology Settings** page:

Time Stamp: 11:45:37.131 Data: 010599907520024610016<0x1d>21096099 Data Matrix 18x18 10.0ppm

With incremental training enabled, you can train the reader using multiple images showing the symbologies you expect to decode. The reader will train each new symbology while retaining the existing trained symbologies.

# Cleaning and Maintenance

## Cleaning the Reader Housing

To clean the outside of the reader housing, use a small amount of mild detergent cleaner or isopropyl alcohol on a cleaning cloth. Do not pour the cleaner directly onto the reader housing.

---

 **CAUTION:** Do not attempt to clean any DataMan product with harsh or corrosive solvents, including lye, methyl ethyl ketone (MEK) or gasoline.

---

## Cleaning the Reader Lens Cover

To remove dust from the lens cover, use a pressurized air duster. The air must be free of oil, moisture or other contaminants that could remain on the lens cover. To clean the plastic window of the lens cover, use a small amount of isopropyl alcohol on a cleaning cloth. Do not scratch the plastic window. Do not pour the alcohol directly on the plastic window.

# Precautions

To reduce the risk of injury or equipment damage, observe the following precautions when you install the Cognex product:

- This device requires the use of an LPS or NEC class 2 power supply (non-PoE device) or the use of a PoE Class 1 (PoE device).
- Do not connect or disconnect this device from the I/O module or 15-pin USB adapter cable when the I/O module or adapter cable is connected to a PC.
- Route cables and wires away from high-current wiring or high-voltage power sources to reduce the risk of damage or malfunction from the following causes: over-voltage, line noise, electrostatic discharge (ESD), power surges, or other irregularities in the power supply.
- Changes or modifications not expressly approved by the party responsible for regulatory compliance could void the user's authority to operate the equipment.
- Ensure that the cable bend radius begins at least six inches from the connector. Cable shielding can be degraded or cables can be damaged or wear out faster if a service loop or bend radius is tighter than 10X the cable diameter.
- This device should be used in accordance with the instructions in this manual.
- All specifications are for reference purposes only and can change without notice.

# Regulations/Conformity

The DataMan 260 has Regulatory Models 1AA5, 1ABD, 1AA0, 1ABF and meets or exceeds the requirements of all applicable standards organizations for safe operation. However, as with any electrical equipment, the best way to ensure safe operation is to operate them according to the agency guidelines that follow. Please read these guidelines carefully before using your device.

**Note:** For the most current CE declaration and regulatory conformity information, see the Cognex support site: [cognex.com/support](http://cognex.com/support).

**CAUTION:** This device requires the use of a PoE Class 1 or 24V DC LPS power supply.

**CAUTION:** IP protection is ensured only when all connectors are attached to cables or shielded by a sealing cap.

Safety and Regulatory	
Manufacturer	Cognex Corporation One Vision Drive Natick, MA 01760 USA
USA	FCC 47 CFR Part 15 Subpart B, Class A This device complies with Part 15 of the FCC Rules. Operation is subject to the following two conditions: (1) this device may not cause harmful interference; and (2) this device must accept any interference received, including interference that may cause undesired operation. This equipment generates, uses, and can radiate radio frequency energy and, if not installed and used in accordance with the instruction manual, may cause harmful interference to radio communications. Operation of this equipment in a residential area is likely to cause harmful interference in which case the user will be required to correct the interference at their own expense.
Canada	ICES-003, Class A This Class A digital apparatus complies with Canadian ICES-003. Cet appareil numérique de la classe A est conforme à la norme NMB-003 du Canada.
Europe	EN55022 (CISPR 22) Class A EN55024 EN60950 This is a class A product. In a domestic environment this product may cause radio interference in which case the user may be required to take immediate measures. This equipment complies with the essential requirements of the EU Directive 2014/30/EU. Declarations are available from your local representative. The CE mark on the product indicates that the system has been tested to and conforms with the provisions noted within the 2014/30/EU Electromagnetic Compatibility Directive. For further information please contact: Cognex Corporation, One Vision Drive Natick, MA 01760 USA. Cognex Corporation shall not be liable for use of our product with equipment (i.e., power supplies, personal computers, etc.) that is not CE marked.
Australia	C-TICK, AS/NZS CISPR 22 / EN 55022 for Class A Equipment
Korea	KN22, KN24 A급 기기(업무용 방송통신기자재): 이 기기는 업무용(A급) 전자파적합기기로서 판매자 또는 사용자는 이 점을 주의하시기 바라며, 가정외의 지역에서 사용하는 것을 목적으로 합니다. Certificate number: MSIP-REM-CGX-DM260 MSIP-REM-CGX-DM262X MSIP-REM-CGX-DM260PoE
Japan	VCCI V-3/2015.04 Class A この装置は、クラスA情報技術装置です。この装置を家庭環境で使用すると電波妨害を引き起こすことがあります。この場合には使用者が適切な対策を講ずるよう要求されることがあります。 VCCI-A

<b>Safety and Regulatory</b>	
UL and cUL Statement  	UL and cUL listed: IEC 60950-1:2005 (2nd Edition); Am 1:2009 + Am 2:2013



## For European Community Users

Cognex complies with Directive 2012/19/EU OF THE EUROPEAN PARLIAMENT AND OF THE COUNCIL of 4 July 2012 on waste electrical and electronic equipment (WEEE).

This product has required the extraction and use of natural resources for its production. It may contain hazardous substances that could impact health and the environment, if not properly disposed.

In order to avoid the dissemination of those substances in our environment and to diminish the pressure on the natural resources, we encourage you to use the appropriate take-back systems for product disposal. Those systems will reuse or recycle most of the materials of the product you are disposing in a sound way.



The crossed out wheeled bin symbol informs you that the product should not be disposed of along with municipal waste and invites you to use the appropriate separate take-back systems for product disposal.

If you need more information on the collection, reuse, and recycling systems, please contact your local or regional waste administration.

You may also contact your supplier for more information on the environmental performance of this product.



Reset Scanner to  
Factory Defaults



Reboot Scanner

