

DataMan[®] 60 Reference Manual

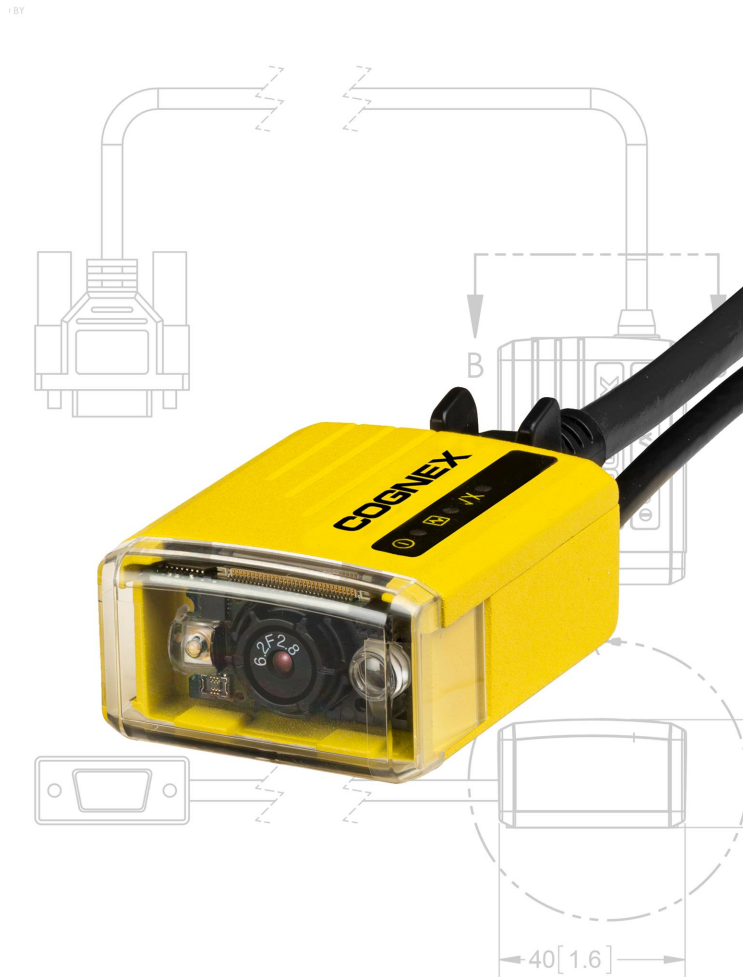

2020 April 14
Revision: 6.1.6.4

Legal Notices

The software described in this document is furnished under license, and may be used or copied only in accordance with the terms of such license and with the inclusion of the copyright notice shown on this page. Neither the software, this document, nor any copies thereof may be provided to, or otherwise made available to, anyone other than the licensee. Title to, and ownership of, this software remains with Cognex Corporation or its licensor. Cognex Corporation assumes no responsibility for the use or reliability of its software on equipment that is not supplied by Cognex Corporation. Cognex Corporation makes no warranties, either express or implied, regarding the described software, its merchantability, non-infringement or its fitness for any particular purpose.

The information in this document is subject to change without notice and should not be construed as a commitment by Cognex Corporation. Cognex Corporation is not responsible for any errors that may be present in either this document or the associated software.

Companies, names, and data used in examples herein are fictitious unless otherwise noted. No part of this document may be reproduced or transmitted in any form or by any means, electronic or mechanical, for any purpose, nor transferred to any other media or language without the written permission of Cognex Corporation.

Copyright © 2019. Cognex Corporation. All Rights Reserved.

Portions of the hardware and software provided by Cognex may be covered by one or more U.S. and foreign patents, as well as pending U.S. and foreign patents listed on the Cognex web site at: cognex.com/patents.

The following are registered trademarks of Cognex Corporation:

Cognex, 2DMAX, Advantage, AlignPlus, Assemblyplus, Check it with Checker, Checker, Cognex Vision for Industry, Cognex VSOC, CVL, DataMan, DisplayInspect, DVT, EasyBuilder, Hotbars, IDMax, In-Sight, Laser Killer, MVS-8000, OmniView, PatFind, PatFlex, PatInspect, PatMax, PatQuick, SensorView, SmartView, SmartAdvisor, SmartLearn, UltraLight, Vision Solutions, VisionPro, VisionView

The following are trademarks of Cognex Corporation:

The Cognex logo, 1DMax, 3D-Locate, 3DMax, BGAll, CheckPoint, Cognex VSoC, CVC-1000, FFD, iLearn, In-Sight (design insignia with cross-hairs), In-Sight 2000, InspectEdge, Inspection Designer, MVS, NotchMax, OCRMax, PatMax RedLine, ProofRead, SmartSync, ProfilePlus, SmartDisplay, SmartSystem, SMD4, VisiFlex, Xpand

Portions copyright © Microsoft Corporation. All rights reserved.

Portions copyright © MadCap Software, Inc. All rights reserved.

Other product and company trademarks identified herein are the trademarks of their respective owners.

Table of Contents

Legal Notices	2
Table of Contents	3
Symbols	5
Getting Started	6
About DataMan 60	6
DataMan 60 Accessories	7
Cables	7
Power Supply	7
Mounting Brackets	7
Control Box	8
DataMan 60 Systems	9
Model Limitations	9
ReaderLayout	10
Indicator LED	10
Dimensions	11
Setting Up Your DataMan 60	13
Setting the Focus Position	13
Field of View and Reading Distances	14
DataMan 60 Specifications	15
DataMan 60 Imager Specifications	16
LED Wavelengths	16
Using Your DataMan 60	17
Install Your DataMan 60	17
DataMan 60 Triggering	17
External Triggers	18
Connections, Optics and Lighting	19
I/O Cable	19
USB and Flying Leads I/O Cable	20
RS-232 and Flying Leads I/O Cable	20
Flying Leads Cable	22
Digital Input Lines	23
External Wiring Examples: Digital Input Lines	23
Digital Output Lines	24
External Wiring Examples: Digital Output Lines	25
Illumination Strobe Output	26
External Load Strobe Output	27
Multi-Port Connections	28
Configuring for Multi-Port Operation	29
Multi-Port Usage Notes	29
Cleaning/Maintenance	30
Cleaning the Reader Housing	30
Cleaning the Reader Lens Cover	30
Compliance Information, Warnings and Notices	31

Compliance Statements 31

Precautions 34

Reader Programming Codes 35

Symbols

The following symbols indicate safety precautions and supplemental information:

 **WARNING:** This symbol indicates a hazard that could cause death, serious personal injury or electrical shock.

 **CAUTION:** This symbol indicates a hazard that could result in property damage.

 **Note:** This symbol indicates additional information about a subject.

 **Tip:** This symbol indicates suggestions and shortcuts that might not otherwise be apparent.

Getting Started

About DataMan 60



DataMan 60 is a compact fixed-mount ID reader that among others offers the following advanced features:

- Smallest high-performance fixed mount reader
- Highest read rates for 1-D and 2-D codes
- Reliability and image feedback

DataMan 60 readers support RS-232, USB, and Ethernet interface connections plus discrete I/O.





The DataMan 60 reader is packaged in an IP40-rated housing.

This document provides basic information about how to configure and use DataMan 60 readers. Additional information is available through the Windows **Start** menu or the DataMan Setup Tool **Help** menu after you install the DataMan software on your PC:

- The **DataMan Communications & Programming Guide** shows how to integrate your DataMan reader with your automation software and factory network.
Cognex->DataMan Software v x.x.x->Documentation->Communications And Programming
- The **DataMan Reader Configuration Codes** document provides printable 2-D codes that you can use to configure the DataMan reader.
Cognex->DataMan Software v x.x.x->Documentation->English->Reader Configuration Codes
- The **DataMan Fixed Mount Readers Reference** is a complete online hardware reference for the DataMan fixed-mount ID readers.
Cognex->DataMan Software v x.x.x->Documentation->English->DM60 ->Fixed Mount Reference Manual
- The **DataMan Questions and Answers** document provides context-sensitive information. You can view this help inside the DataMan Setup Tool or as a stand-alone help file.
Cognex->DataMan Software v x.x.x->Documentation->DM60->Questions and Answers
- The **Release Notes** list detailed system requirements and additional information about this DataMan software release.
Cognex->DataMan Software v x.x.x->Documentation->DataMan v x.x.x Release Notes

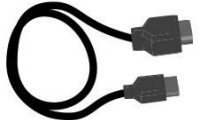
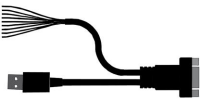
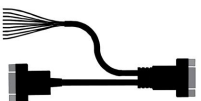
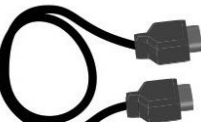
DataMan 60 Accessories

Cables

USB Cable, 1.5 m (DM100-USB-000)	
USB Cable, 3 m (DM100-USB-030)	
USB and Flying Leads I/O Cable, 2.0 m (DM-USBIO-00)	
RS-232 and Flying Leads I/O Cable, 2.5 m (DM-RS232IO-00)	
RS-232 Cable, 1.5 m (DM100-RS232-000)	
Extension Cable, 5 m (DM100-EXTCBL-000)	
Flying Leads Connection Cable, 5 m (DM50-PWRIO-05)	
Ethernet Cable: use any standard CAT5/5e, SF/FTP or S/FTP cable	
RS-232/USB adapter connector (DM100-PATCH-000)	

Power Supply

Power Supply, 6 V (DM100-PWR-000)	
-----------------------------------	---

Mounting Brackets

Pivot Mounting Bracket (DM100-PIVOTM-00)	
--	---

Universal Mounting Bracket (DM50-UBRK-000)

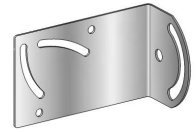

Control Box

Control Box (DM-CTRLBOX-00)



DataMan 60 Systems

	Omni-directional 1-D Code Reading	IDQuick™ — Well marked 2-D Code Reading	1DMax+™ with HOTBARS™
DataMan 60L (DMR-60L-00)			√
DataMan 60QL (DMR-60QL-00)	√		√
DataMan 60S (DMR-60S-00)	√	√	√

Model Limitations

S models do not have Burst and Continuous trigger modes.

	60L	60QL	60S
1-D and Stacked Codes	Yes, oriented	Yes, omnidirectional	Yes, omnidirectional
Omnidirectional 1-D Codes	No	Yes	Yes
2-D Codes	No	No	Yes
Algorithm	1DMax, Hotbars	1DMax, Hotbars	1DMax, Hotbars, IDQuick
Acquisition	Max 60 fps	Max 60 fps	Max 2 fps
Max Decode Rate	45/sec	45/sec	2/sec
Trigger	Manual; External: single, burst and continuous; Internal: self and presentation	Manual; External: single, burst and continuous; Internal: self and presentation	Manual; External: single Internal: self and presentation

ReaderLayout

The following image shows the characteristics of the DataMan 60 reader.

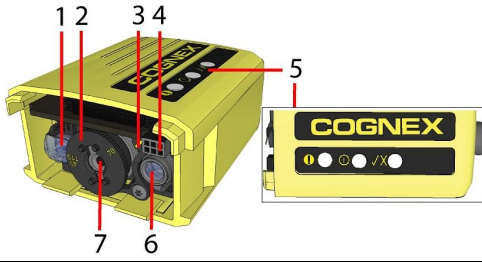

1	Internal illumination
2	3-position lens cap
3	Focal position indicator
4	External illumination connector
5	Status LEDs
6	LED aimer
7	Lens

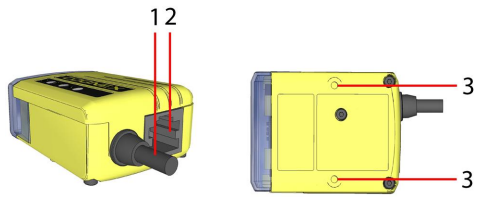

1	Directly connected cable terminating in a DB15 connector providing: power, I/O, USB, and RS-232 connectivity
2	Ethernet RJ-45 connector
3	Mounting points

Indicator LED

Type	Signal	Color	Meaning
Status LED	Power	YELLOW	Power On
	Communication	YELLOW <i>blinking</i>	Activity
	Good/bad read	GREEN	Good read
		RED	Bad read
Error	RED	Error, check device log	

Dimensions

Observe the following DataMan 60 reader dimensions when installing your reader

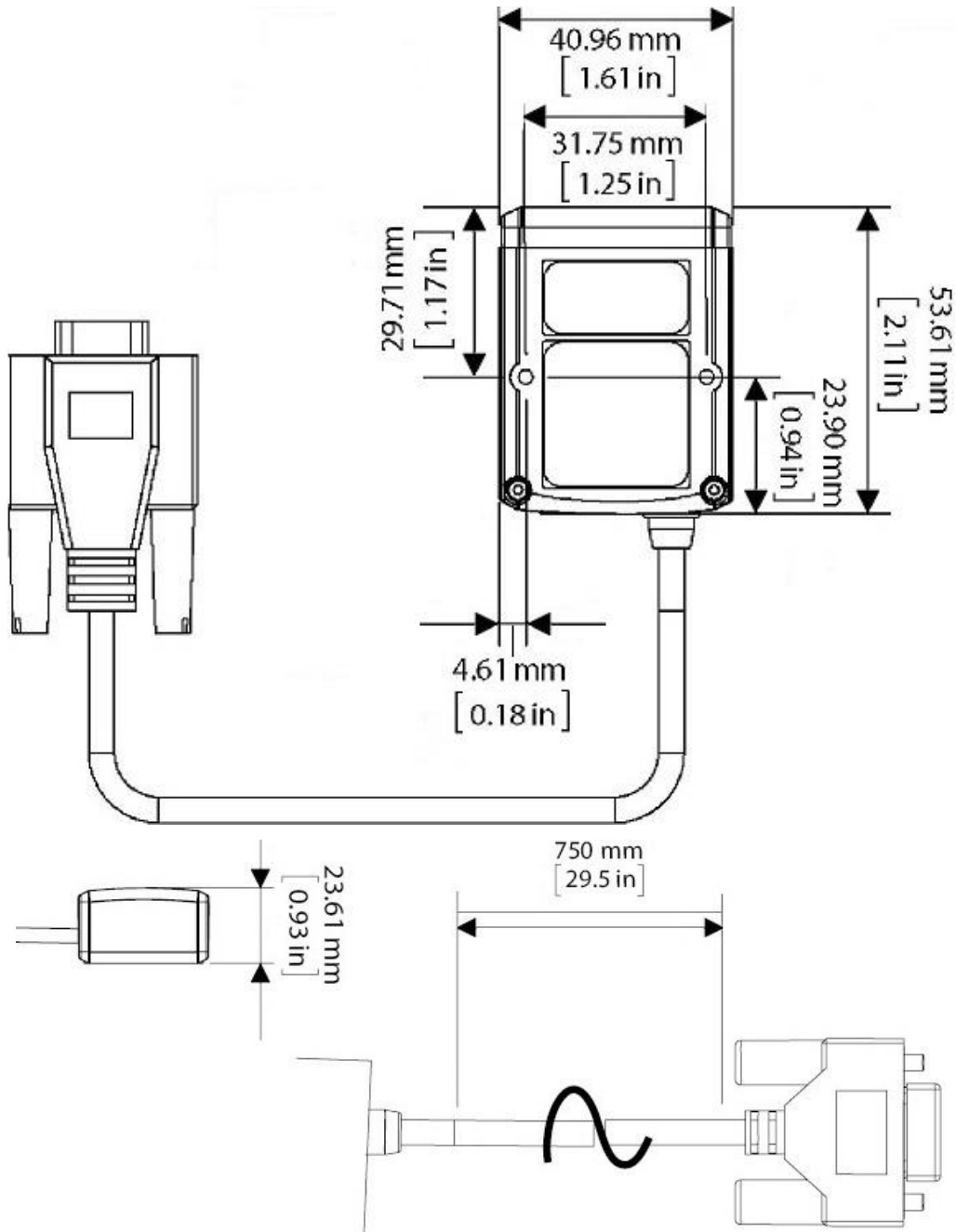

The attachment points have the following characteristics:

- M3 thread
- Maximum thread depth: 6 mm
- 1.3 N-m (11.5 in-lb) maximum torque

CAUTION: Use both attachment points when mounting your device.

 **Tip:** Some applications can benefit from mounting the system at a slight angle (15 degrees) to reduce reflection from the inspected surface back to the reader.

Setting Up Your DataMan 60

Setting the Focus Position

DataMan 60 can operate in one of three distance ranges.

To set the focus position:

1. Remove the lens cover.

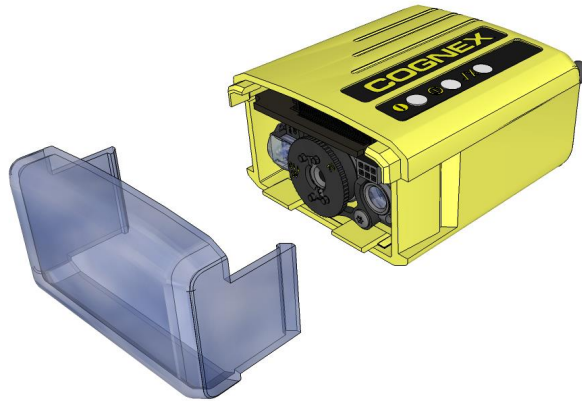

2. Set the focus position to 45, 70, or 110: turn the lens cap clockwise (45->70->110) to focus to a larger distance; turn the lens cap counter-clockwise (110->70->45) to focus to a shorter distance.

3. Reattach the front cover.

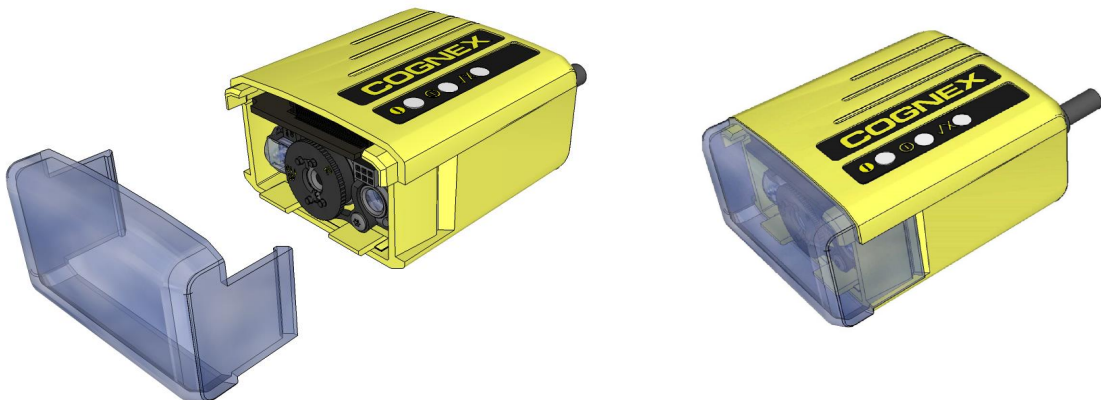

Field of View and Reading Distances

The following charts show the field of view (FoV) of the DataMan 60 series readers. Reading distance values are also provided for 1-D and 2-D example code distances.

This chart shows the supported range of reading distances at **45 mm** focus position.

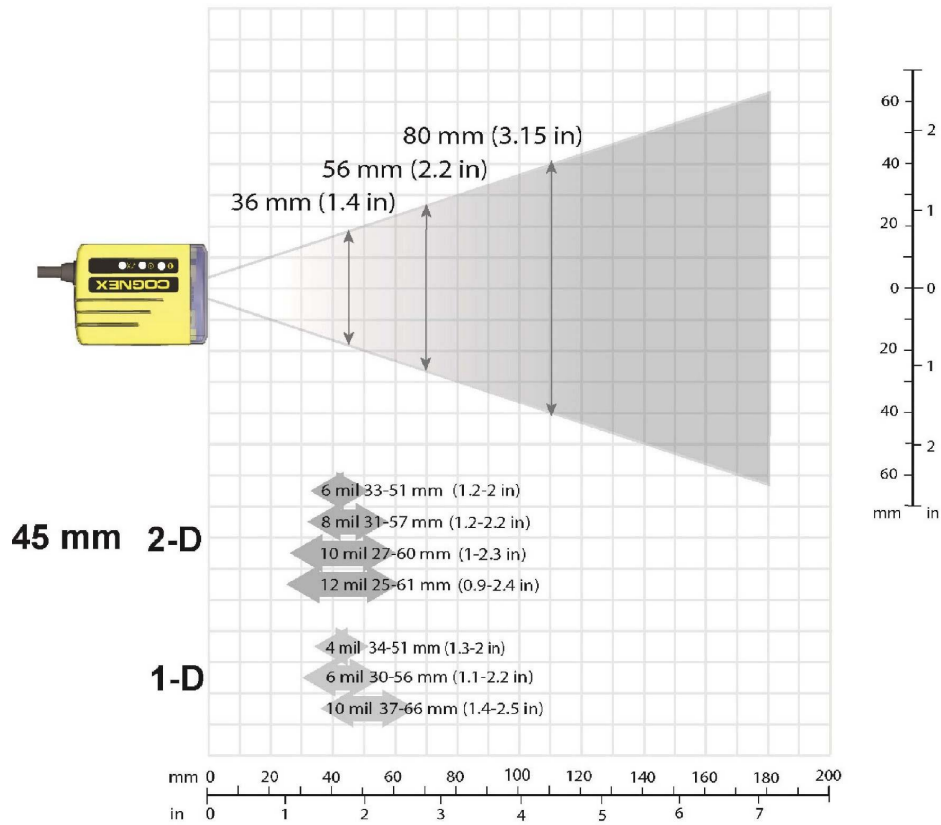

This chart shows the supported range of reading distances at **70 mm** focus position.

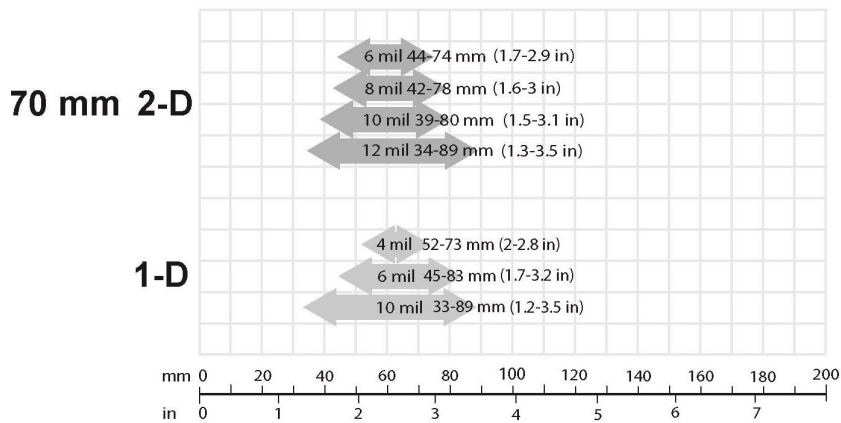

This chart shows the supported range of reading distances at **110 mm** focus position.

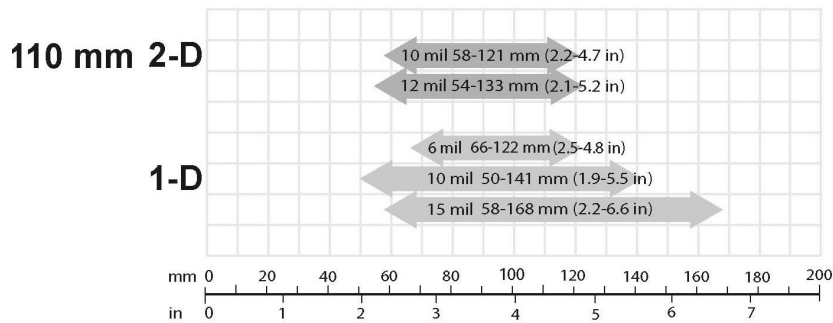

The following table shows the FoV widths in mm at various distances.

Distances in mm	DataMan 60
45	36
70	56
110	80

DataMan 60 Specifications

Weight	98 g (including cable)		
Operating Temperature	0 °C — 40 °C (32 °F — 104 °F)		
Storage Temperature	-10 °C — 60 °C (-14 °F — 140 °F)		
Maximum Humidity	95% (non-condensing)		
Environmental	IP40		
Vibration	IEC 60068-2-6 and 60068-2-27		
LED Safety	IEC 62471: Exempt risk group, no further labeling is required.		
Codes	1-D barcodes: Codabar, Code 39, Code 128, and Code 93, Interleaved 2 of 5, Pharma, GS1 DataBar, Postal, UPC/EAN/JAN 2-D barcodes: Data Matrix™ QR Code and microQR Code, MaxiCode, RSS/CS, PDF 417, MicroPDF 417		
Discrete I/O Operating Limits	Output 0,1	I_{MAX} @ 24 VDC	25 mA
		V_{MAX}	24 V
	Output 2	Source V_{TYP}	4 V
		Sink V_{IH}	4 V - V_{PSU}
		V_{IL}	0 — 2 V
	Input 0 (Trigger)	V_{IH}	4 — 26 V
	Input 1	V_{IL}	0 — 2 V
		I_{TYP}	3 mA
Power Supply Requirements	V_{PSU} 4,5 — 24 VDC 2.5 W maximum LPS or NEC class 2 power supply		
Ethernet Speed	10/100		
Duplex Mode	Full duplex or half duplex		

DataMan 60 Imager Specifications

Specification	DataMan 60 Series Imager
Image Sensor	1/3 inch CMOS
Image Sensor Properties	4.51 mm x 2.88 mm (H x V), 6.0 µm square pixels
Image Resolution (pixels)	752 x 480
Electronic Shutter Speed	18 µs to 25 ms exposure
Image Acquisition	up to 60 fps at full resolution
Lens Type	6.2 mm, F:5,3 focal position M12 lens with IR blocking filter

LED Wavelengths

The following table shows LED types and the related wavelengths:

LED	λ [nm]
RED	617

Using Your DataMan 60

Install Your DataMan 60

Perform the following steps to install the DataMan Setup Tool:

1. Check the **DataMan Release Notes** for a full list of system requirements.
2. Download the DataMan Setup Tool from <http://www.cognex.com/support/dataman> and follow the on-screen steps.
3. Connect the DataMan 60 reader to your PC.
4. Choose **Start > Programs > Cognex > DataMan Software v x.x.x > Setup Tool** to launch the DataMan Setup Tool. The detected readers will appear under the **COM ports**.
5. Click **Refresh** to update the list of connected devices.
6. Select a COM port that lists DataMan 60 and click **Connect**.

Follow the steps below to connect your reader to power and network:

1. Connect the cable on the back of the device to either a USB adapter cable with power tap or to an RS-232 adapter cable with power tab.
2. Connect a 6 V power supply.
3. Connect the reader to an Ethernet network.

DataMan 60 Triggering

DataMan 60 readers support the following trigger modes:

- **Self:** At an interval you configure, the reader automatically detects and decodes codes in its field of view. If you set a higher re-read delay than the trigger interval, there is a code output only once until the code is out of the field of view for the duration of the re-read delay.
- **Single (external trigger):** Acquires a single image and attempts to decode any symbol it contains, or more than one symbol in cases where multicode is enabled. The reader relies on an external trigger source.
- **Presentation:** Scans, decodes and reports a single code in the field of view. The reader relies on an internal timing mechanism to acquire images.
- **Manual:** Begins acquiring images when you press the trigger button on the reader, and continues acquiring images until a symbol is found and decoded or you release the button.
- **Burst:** Performs multiple image acquisitions based on an external trigger and decodes any symbol appearing in a single image or within a sequence of images, or multiple symbols in a single image or within a sequence of images when multicode is enabled. You can control the number of images within each burst and the interval between image acquisitions.
- **Continuous:** Begins acquiring images based on a single external trigger and continues to acquire and decode images until a symbol is found and decoded, or until multiple images containing as many codes as specified in multicode mode are located, or until the trigger is released. You can configure your reader to acquire images based on the start and stop signal from separate digital IO pulses.

S models do not have Burst and Continuous trigger modes.

External Triggers

If you are using external triggering, you can use any of these methods to trigger your DataMan 60 series reader:

- Send a pulse on the I/O cable:
 - Input 0 (white)
 - Input 1 (white/black)
- Send a serial trigger command over the RS-232 connection or the Ethernet connection.
- Press <CTRL>-T on the keyboard while the DataMan Setup Tool has the input focus.
- Click the **Trigger** button in the DataMan Setup Tool:



Connections, Optics and Lighting

I/O Cable

The I/O cable provides access to trigger and high-speed outputs. Unused wires can be clipped short or tied back using a tie made of non-conductive material. For RS-232, use the Power Supply return path for ground.

Note: GND (Pin 4) is connected to the reader housing, cable shield, and DB15 shell.

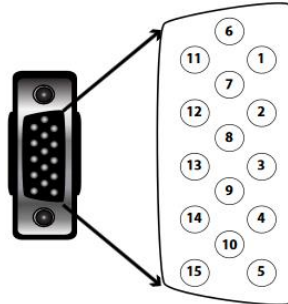

This is a male connector/plug.

PIN	Color	Signal
1	Brown	Reserved
2	Green	TxD
3	Green/Black	RxD
4	Red and Brown/White	GND
5	Red/Black	DC+ (system power, 5-24 VDC)
6	Blue	RTS
7	Blue/White	Output-0
8	White	Input-0
9	White/Black	Input-1
10	Light Blue	CTS
11	Light Blue/Black	Output-1
12	Light Blue/Yellow	Output-Common
13	Light Blue/Green	Output-Strobe
14	Yellow	Reserved
15	Yellow/Black	Reserved

USB and Flying Leads I/O Cable

You can connect a cable with USB and flying leads (DM-USBIO-00) to the cable that is attached to the device. The following table shows the pinout and color description of the flying leads.

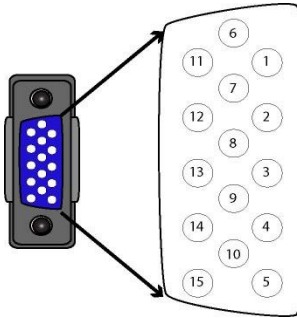

This is a female connector/socket.

PIN	Color	Signal
4	Black	GND
7	Blue/White	Output-0
8	White	Input-0
9	White/Black	Input-1
11	Light Blue/Black	Output-1
12	Light Blue/Yellow	Output-Common
13	Light Blue/Green	Output-Strobe

RS-232 and Flying Leads I/O Cable

You can connect a cable with RS-232 and flying leads (DM-RS232IO-00) to the cable that is attached to the device. The following table shows the pinout and color description of the flying leads.

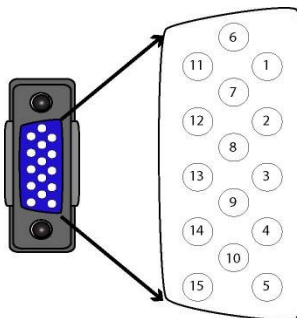

This is a female connector/socket.

PIN	Color	Signal
4	Black	GND
5	Brown/White	VDC
7	Blue/White	Output-0

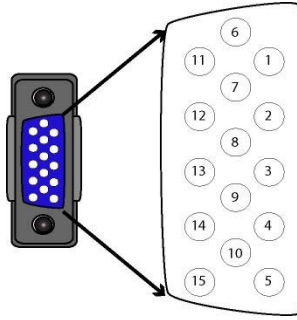

This is a female connector/socket.

PIN	Color	Signal
8	White	Input-0
9	White/Black	Input-1
11	Light Blue/Black	Output-1
12	Light Blue/Yellow	Output-Common
13	Light Blue/Green	Output-Strobe

Flying Leads Cable

You can connect a cable with flying leads (DM50-PWRIO-05) to the cable that is attached to the device. The following table shows the pinout and color description of the flying leads.

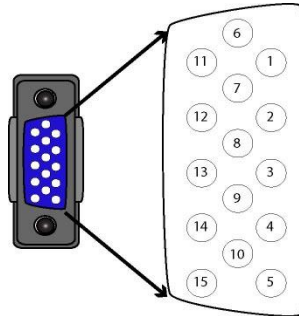

This is a female connector/socket.

IN	Color	Signal
2	Green	TxD
3	Green/Black	RxD
4	Red	GND
5	Brown/White	DC+ (system power, 5-24 VDC)
6	Blue	RTS
7	Blue/White	Output-0
8	White	Input-0
9	White/Black	Input-1
10	Light Blue	CTS
11	Light Blue/Black	Output-1
12	Light Blue/Yellow	Output-Common
13	Light Blue/Green	Output-Strobe

Digital Input Lines

Inputs are not galvanic isolated but need to be referenced to ground.

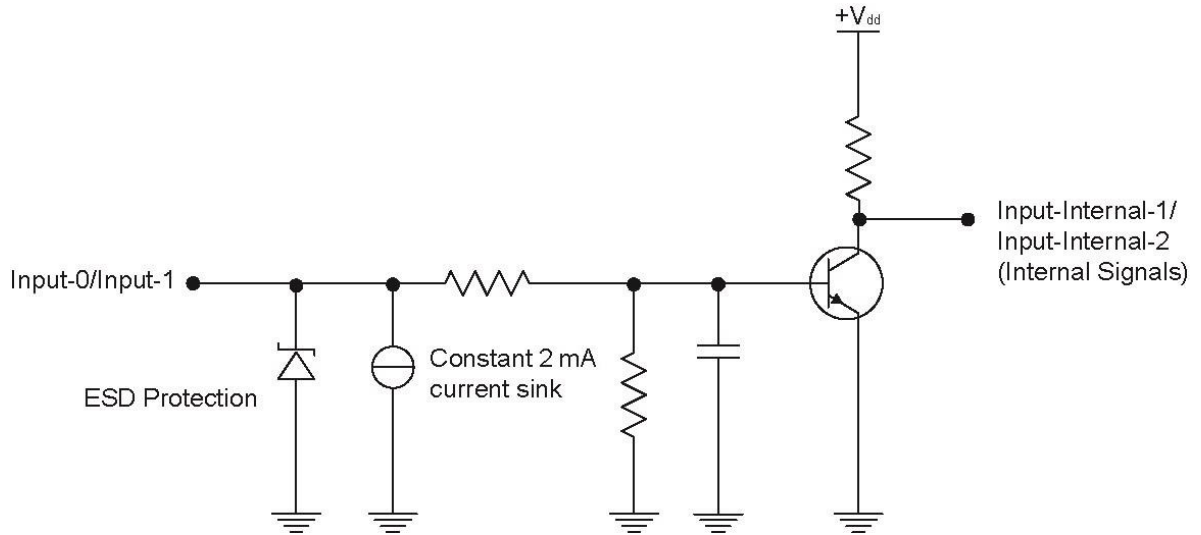

External Wiring Examples: Digital Input Lines

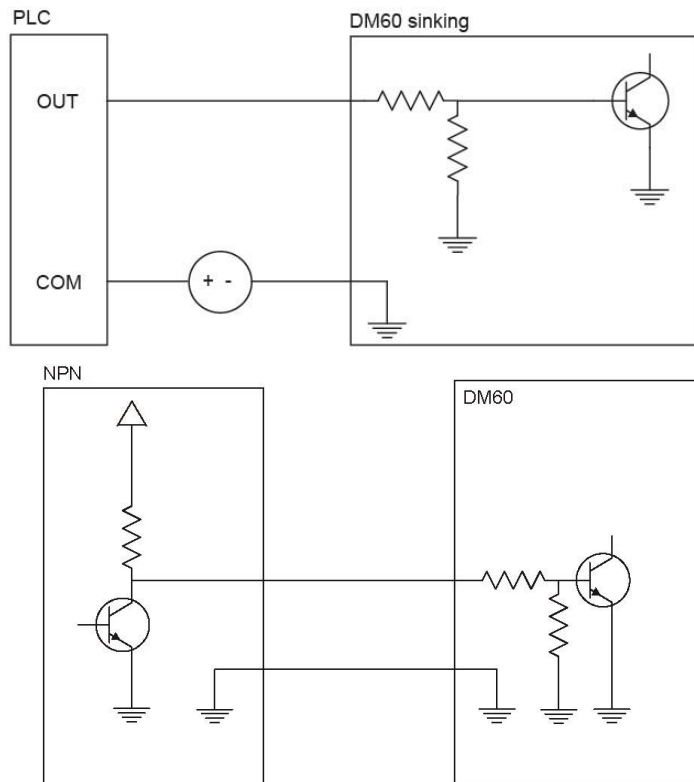

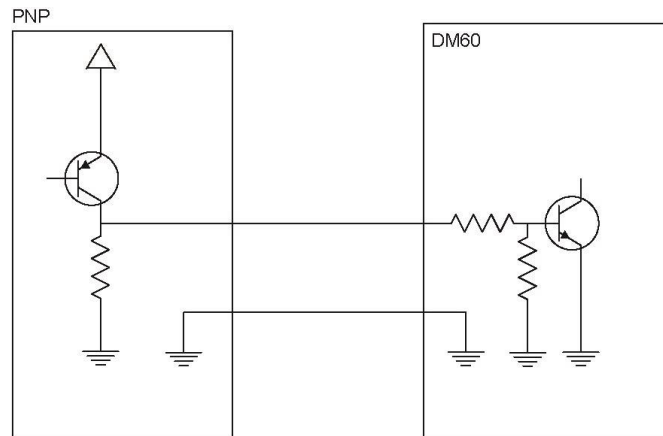

Digital Output Lines

The digital outputs can be used as either NPN (pull-down) or PNP (pull-up) lines. For NPN lines, the external load should be connected between the output and the positive supply voltage (<24 V). The outputs pull down to less than 3 V when ON, which causes current to flow through the load. When the outputs are OFF, no current flows through the load. Outputs are not galvanic isolated but need to be referenced to ground.

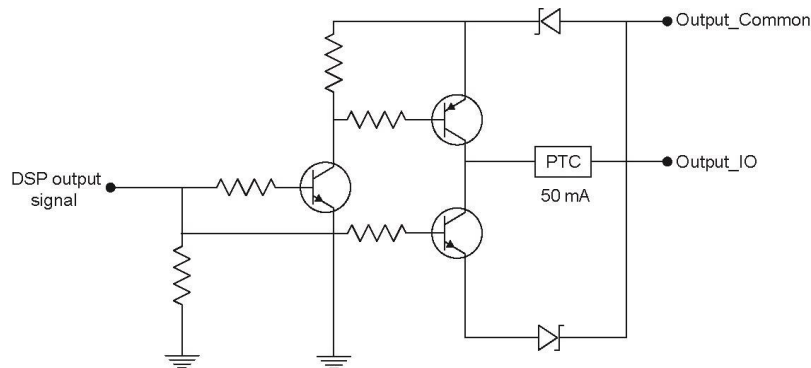

NPN (pull down) output type characteristics	
Applied voltage	24 VDC or less
Residual voltage	0.85V or less
Maximum sink current	25 mA
Short-circuit current	100 mA or less
Short-circuit protection	multifuse - 50 mA

PNP (pull up) output type characteristics	
Applied voltage	24 V or less
Residual voltage	0.8 V or less
Maximum sink current	25 mA
Short-circuit current	50 mA or less
Short-circuit protection	multifuse - 50 mA

External Wiring Examples: Digital Output Lines

NPN:

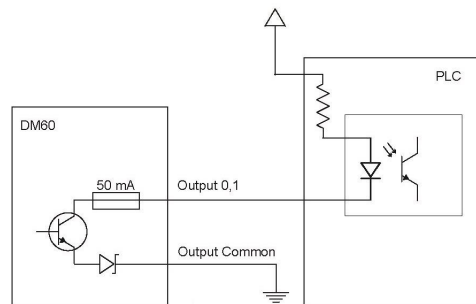
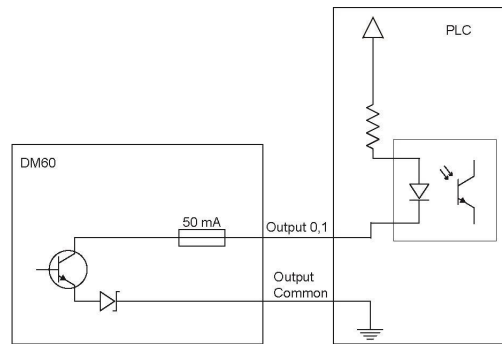

PNP:

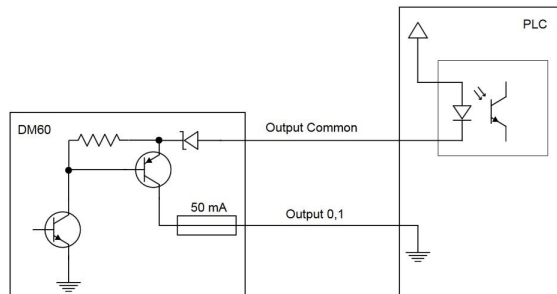
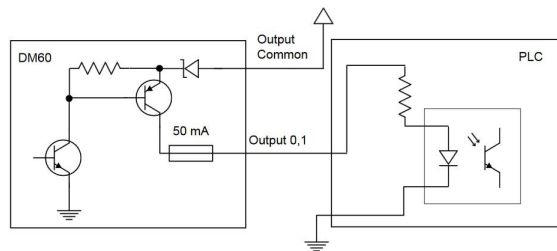

Illumination Strobe Output

The strobe output is provided by a diode that is added to the push-pull circuit, with series to the pull-up transistor. This diode blocks the higher voltage when the output is pulled up when used as open-collector type driving, but enables the driving of high level in TTL mode.

TTL output type characteristics	
High level	4.0-5.0 V
Low level	0-0.4 V
Output current	25 mA
Short-circuit current	125 mA
Short-circuit protection	multifuse - 50 mA

Open-collector output type characteristics	
Output voltage range	0-24 V
Low level	0-0.4 V
Output current	25 mA max
Short-circuit current	125 mA
Short-circuit protection	multifuse - 50 mA

The following figure shows the wiring diagram of the illumination strobe output:

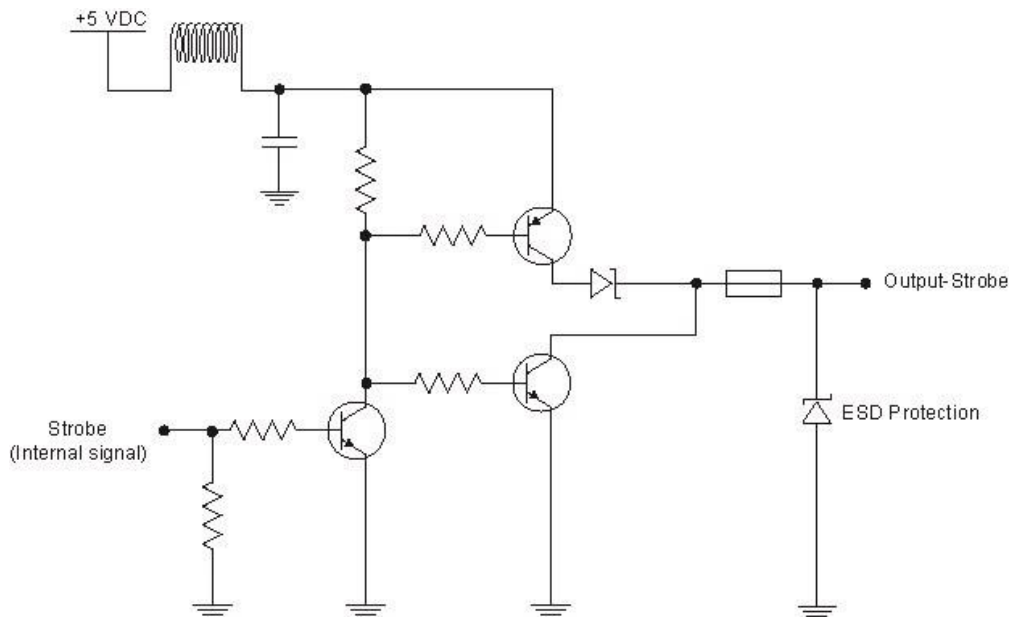

External Load Strobe Output

NPN:

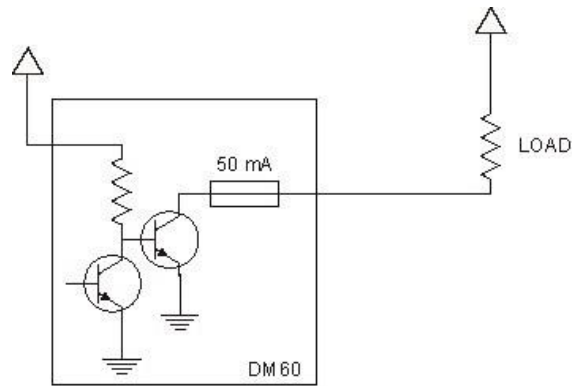

PNP:

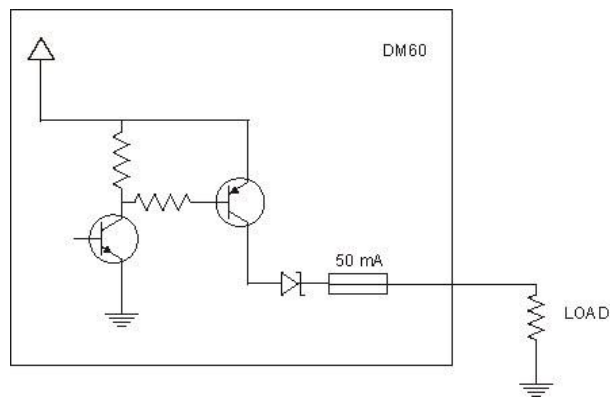

Multi-Port Connections

You can connect multiple DataMan 60 readers to a single PC (or other device equipped with a serial port) using a multi-port connection.

A multi-port connection creates a daisy-chain of readers. Each reader receives serial data from the previous reader and transmits it to the next reader. When a reader transmits data, it is passed through each of the readers in the chain between it and the PC.

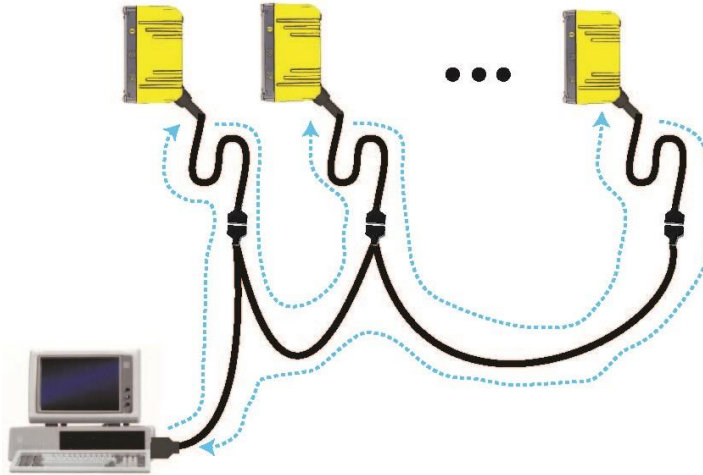

Because of the large number of possible configurations, Cognex does not supply cabling for multi-port DataMan 60 connections. Instead, you must construct your own cable that meets the requirements of your system configuration.

The cable must provide a DB9 connector for each DataMan 60 serial cable and a DB9 connector for the PC serial port. Each DB9 connector must provide Tx Data, Rx Data, and ground. The Tx Data and Rx Data pins on adjacent connectors must be connected to provide the multi-port connection.

The following diagram shows how to create a multi-port cable for a 3-reader system:

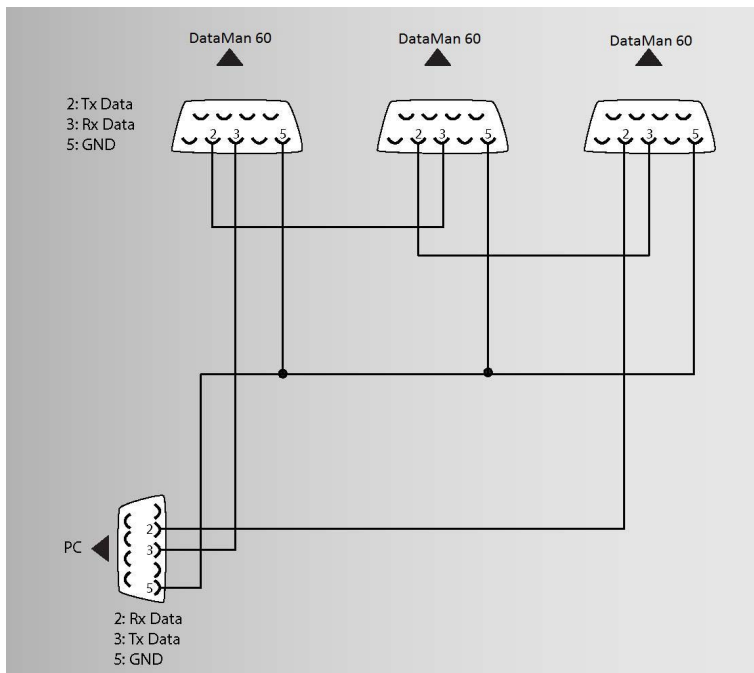

Configuring for Multi-Port Operation

You must connect the DataMan Setup Tool to each DataMan 60 in turn and enable multi-port operation. Click the **Communication Settings** pane, the **Serial** tab and check the **Enable Multi-Port (RS-232 Sharing)** checkbox.

Enable Multi-Port (RS-232 Sharing)

There is no guaranteed delivery order when multiple readers transmit data using a multi-port connection; read results may arrive at the PC in any order. You can configure each DataMan 60 reader in a multi-port connection to add identifying data to each read result. Your PC application can then determine which reader produced a specific read result.

To do this, click on the **Data Formatting** pane, go to **Standard Formatting**, select the **Data Matrix** tab and enter text in the **Leading Text** field. (You can also add trailing text by entering text in the **Terminating Text** field.)

The screenshot shows the 'Standard Formatting' dialog box. At the top, there are five tabs: 'Data Matrix', 'QR Code / MaxiCode / Aztec Code', 'DotCode', '1D / Stacked / Postal', and 'Universal'. The 'Data Matrix' tab is active. Below the tabs is a 'Leading Text' field containing the text 'Reader1'. Underneath is a 'Data' section with two sub-tabs: 'General' and 'Validation'. The 'General' sub-tab is selected, showing two radio button options: '<Sub-string>' and '<Full string>'.

Multi-Port Usage Notes

You can obtain the best results when using multi-port connections by keeping the following usage guidelines in mind as you design your system:

- The maximum cable length between any two DataMan readers or between the PC and any DataMan reader should be no greater than 15 meters.
- There is no fixed limit to the number of DataMan readers that you can connect to a single PC. Each reader introduces a delay of about 100 msec when it retransmits received serial data. If you have 5 readers, this means that there will be a 400 msec delay between the time the first reader in the chain transmits data and the PC receives it.
- Each DataMan reader must receive a hardware trigger signal on its Input 0 line. You can wire the input ports to a common trigger signal or you can provide individual triggers for each reader.
- If any reader in the multi-port chain loses power or becomes disconnected, then no data from any other reader will be transmitted.
- If a DataMan is transmitting its own read result, it will buffer any data received from another reader until it has finished its own data transmission. If a DataMan reader is transmitting another reader's data, it will buffer its own data if it receives a trigger signal while it is processing the other reader's data.
- If you use a single power supply for multiple readers, make sure that the power supply can provide enough power for all of the readers.
- You cannot connect a reader to the DataMan Setup Tool over RS-232 once multiport is enabled. You must first scan the Disable Multi-Port code from the **Reader Configuration Codes**, available from the **Start** menu.

Cleaning/Maintenance

Cleaning the Reader Housing

To clean the outside of the reader housing, use a small amount of mild detergent cleaner or isopropyl alcohol on a cleaning cloth. Do not pour the cleaner directly onto the reader housing.

 **CAUTION:** Do not attempt to clean any DataMan product with harsh or corrosive solvents, including lye, methyl ethyl ketone (MEK) or gasoline.

Cleaning the Reader Lens Cover

To remove dust from the lens cover, use a pressurized air duster. The air must be free of oil, moisture or other contaminants that could remain on the lens cover. To clean the plastic window of the lens cover, use a small amount of isopropyl alcohol on a cleaning cloth. Do not scratch the plastic window. Do not pour the alcohol directly on the plastic window.

Compliance Information, Warnings and Notices

Note: For product support, contact <http://support.cognex.com>.



CAUTION: IP protection is ensured only when all connectors are attached to cables or shielded by a sealing cap.

Compliance Statements

DataMan 60 readers meet or exceed the requirements of all applicable standards organizations for safe operation. However, as with any electrical equipment, the best way to ensure safe operation is to operate them according to the agency guidelines that follow. Please read these guidelines carefully before using your device.

Regulator	Specification
USA	FCC Part 15, Subpart B, Class A
European Community	EN55022, Class A
	EN55024 EN60950

Note: For the most current CE declaration and regulatory conformity information, see the Cognex support site: cognex.com/support.

Safety and Regulatory	
European Compliance 	This is a class A product. In a domestic environment this product may cause radio interference in which case the user may be required to take immediate measures. This equipment complies with the essential requirements of the EU Directive 2014/30/EU. Declarations are available from your local representative. The CE mark on the product indicates that the system has been tested to and conforms with the provisions noted within the 2014/30/EU Electromagnetic Compatibility. For further information please contact: Cognex Corporation, One Vision Drive Natick, MA 01760 USA. Cognex Corporation shall not be liable for use of our product with equipment (i.e., power supplies, personal computers, etc.) that is not CE marked.
FCC Class A Compliance Statement 	This equipment has been tested and found to comply with the limits for a Class A digital device, pursuant to Part 15 of the FCC rules. These limits are designed to provide reasonable protection against harmful interference when the equipment is operated in commercial environment. This equipment generates, uses, and can radiate radio frequency energy and, if not installed and used in accordance with the instructions, may cause harmful interference to radio communications. Operation of this equipment in a residential area is likely to cause harmful interference, in which case the user will be required to correct the interference at personal expense.
UL and cUL Statement 	UL and cUL listed: UL60950-1 1st ed. and CSA C22.2 No.60950-1 1st ed. Certified to CB scheme IEC 60950-1:2001 1st ed.

LED Safety Statement

This device has been tested in accordance with IEC62471, and has been certified to be under the limits of Exempt Risk Group. No further labeling is required.

For European Community Users

Cognex complies with Directive 2012/19/EU OF THE EUROPEAN PARLIAMENT AND OF THE COUNCIL of 4 July 2012 on waste electrical and electronic equipment (WEEE).

This product has required the extraction and use of natural resources for its production. It may contain hazardous substances that could impact health and the environment, if not properly disposed.

In order to avoid the dissemination of those substances in our environment and to diminish the pressure on the natural resources, we encourage you to use the appropriate take-back systems for product disposal. Those systems will reuse or recycle most of the materials of the product you are disposing in a sound way.



The crossed out wheeled bin symbol informs you that the product should not be disposed of along with municipal waste and invites you to use the appropriate separate take-back systems for product disposal.

If you need more information on the collection, reuse, and recycling systems, please contact your local or regional waste administration.

You may also contact your supplier for more information on the environmental performance of this product.

Precautions

To reduce the risk of injury or equipment damage, observe the following precautions when you install the Cognex product:

- Route cables and wires away from high-current wiring or high-voltage power sources to reduce the risk of damage or malfunction from the following causes: over-voltage, line noise, electrostatic discharge (ESD), power surges, or other irregularities in the power supply.
- Changes or modifications not expressly approved by the party responsible for regulatory compliance could void the user's authority to operate the equipment.
- Ensure that the cable bend radius begins at least six inches from the connector. Cable shielding can be degraded or cables can be damaged or wear out faster if a service loop or bend radius is tighter than 10X the cable diameter.
- This device should be used in accordance with the instructions in this manual.
- All specifications are for reference purposes only and can change without notice.

Reader Programming Codes



Reset Scanner to Factory Defaults



Reboot Scanner

