

DataMan[®] 475 Verifier Reference Manual

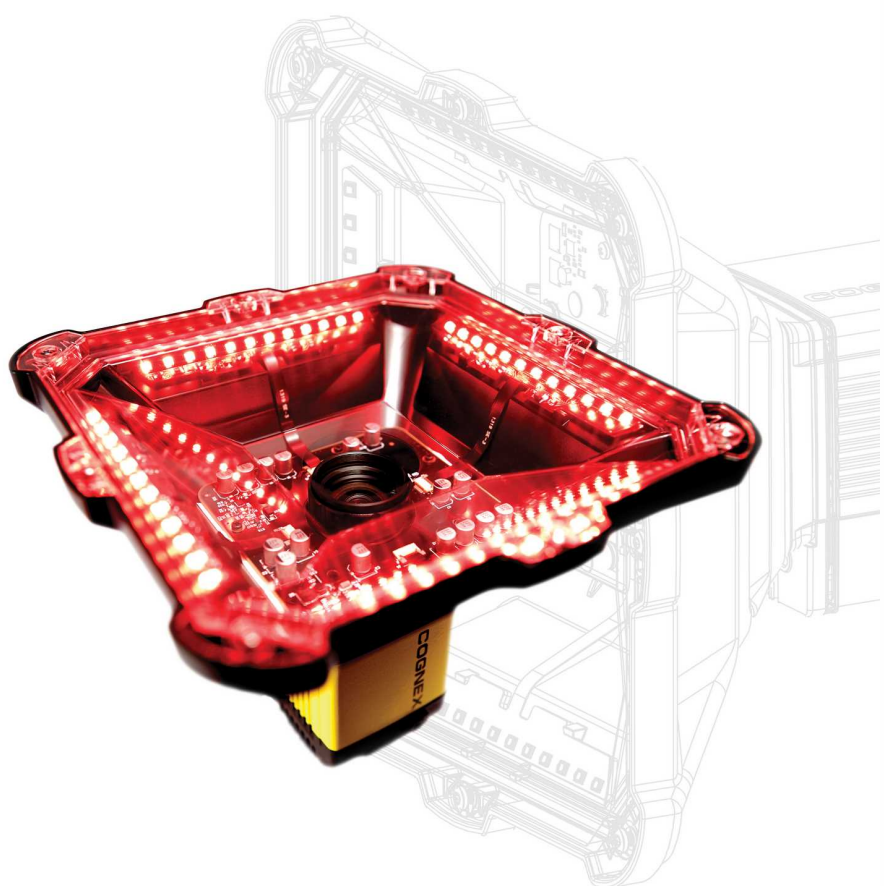

2021 April 14

Revision: 5.7.7SR5.6

Legal Notices

The software described in this document is furnished under license, and may be used or copied only in accordance with the terms of such license and with the inclusion of the copyright notice shown on this page. Neither the software, this document, nor any copies thereof may be provided to, or otherwise made available to, anyone other than the licensee. Title to, and ownership of, this software remains with Cognex Corporation or its licensor. Cognex Corporation assumes no responsibility for the use or reliability of its software on equipment that is not supplied by Cognex Corporation. Cognex Corporation makes no warranties, either express or implied, regarding the described software, its merchantability, non-infringement or its fitness for any particular purpose.

The information in this document is subject to change without notice and should not be construed as a commitment by Cognex Corporation. Cognex Corporation is not responsible for any errors that may be present in either this document or the associated software.

Companies, names, and data used in examples herein are fictitious unless otherwise noted. No part of this document may be reproduced or transmitted in any form or by any means, electronic or mechanical, for any purpose, nor transferred to any other media or language without the written permission of Cognex Corporation.

Copyright © 2020. Cognex Corporation. All Rights Reserved.

Portions of the hardware and software provided by Cognex may be covered by one or more U.S. and foreign patents, as well as pending U.S. and foreign patents listed on the Cognex web site at: cognex.com/patents.

The following are registered trademarks of Cognex Corporation:

Cognex, 2DMAX, Advantage, AlignPlus, Assemblyplus, Check it with Checker, Checker, Cognex Vision for Industry, Cognex VSOC, CVL, DataMan, DisplayInspect, DVT, EasyBuilder, Hotbars, IDMax, In-Sight, Laser Killer, MVS-8000, OmniView, PatFind, PatFlex, PatInspect, PatMax, PatQuick, SensorView, SmartView, SmartAdvisor, SmartLearn, UltraLight, Vision Solutions, VisionPro, VisionView

The following are trademarks of Cognex Corporation:

The Cognex logo, 1DMax, 3D-Locate, 3DMax, BGAll, CheckPoint, Cognex VSoC, CVC-1000, FFD, iLearn, In-Sight (design insignia with cross-hairs), In-Sight 2000, InspectEdge, Inspection Designer, MVS, NotchMax, OCRMax, PatMax RedLine, ProofRead, SmartSync, ProfilePlus, SmartDisplay, SmartSystem, SMD4, VisiFlex, Xpand

Portions copyright © Microsoft Corporation. All rights reserved.

Portions copyright © MadCap Software, Inc. All rights reserved.

Other product and company trademarks identified herein are the trademarks of their respective owners.

Table of Contents

Legal Notices	2
Table of Contents	3
Symbols	5
Getting Started	6
About the DataMan 475 Verifier	6
Supportive Documentation	6
Configuration	6
DataMan 475 Verifier Accessories	7
Cables and Power Supply	7
Mounting Brackets	8
DataMan 475 Verifier Systems	8
Setting Up Your DataMan 475 Verifier	9
Reader Layout	9
Dimensions	10
DataMan 475 Verifier	11
Additional Information	11
DataMan 475 Verifier Specifications	11
DataMan 475 Series Verifier Imager Specifications	12
LED Wavelengths	12
Calibration	13
User Interface	16
Toolbar	16
Using Your DataMan 475 Verifier	17
Verifying a 2D Barcode	17
Selecting Regions	18
Standards Based Grading	19
Verifications of Multiple Symbols	19
Examining the Results	21
1D & 2D Verification	21
Main Tab	21
General Characteristics Tab	22
Data Detail Tab	23
Quality Detail Tab	25
Advanced Detail Tab	25
Histogram Tab	26
Report Tab	27
Settings	28
Accessing the Settings Menu	28
Application Settings	28
Application Standards Settings	28
Grading Standards	32
Data Format Check	32
Auto Aperture	35

Navigation	35
Results through Setup Tool (local machine)	36
Results through FTP	37
Symbologies/Multi Mode	38
Scripting	39
Setting Up FTP Transfer	40
Image FTP Transfer	40
Result FTP Transfer	41
Report FTP Transfer	41
Grading Standards and their Parameters	42
ISO/IEC 15415 Grading Parameters	42
ISO 18004 QR Code Grading Parameters	46
ISO 29158 (AIM-DPM) 2006 Grading Parameters	47
Traditional (Non-Graded) Parameters	48
PCS	48
MRD	48
ISO/IEC 15416 (ANSI x3.182) Grading Parameters	48
Setting Up DataMan Setup Tool	52
Reading your first Code	52
External Triggers	54
Cleaning and Maintenance	55
Cleaning the Verifier Housing	55
Cleaning the Verifier Lens Cover	55
Compliance Information, Warnings and Notices	56
Precautions	56
Regulations/Conformity	57
For European Community Users	57

Symbols

The following symbols indicate safety precautions and supplemental information:

 **WARNING:** This symbol indicates a hazard that could cause death, serious personal injury or electrical shock.

 **CAUTION:** This symbol indicates a hazard that could result in property damage.

 **Note:** This symbol indicates additional information about a subject.

 **Tip:** This symbol indicates suggestions and shortcuts that might not otherwise be apparent.

Getting Started

This section provides general information about the DataMan 475 Verifier and the DataMan 475 Verifier accessories and systems.

About the DataMan 475 Verifier



The DataMan 475 Verifier provides immediate quality assurance benefits:

- Sets alerts for when code quality begins to degrade
- Grades up to 20 codes per second
- Exports verification results to PLC, database, or FTP server as CSV, HTML, PDF, or custom formats
- Improves processes with detailed analysis and diagnostic information for every code

The DataMan 475 four-quadrant, 45-degree lighting attachment is compliant with the International Organization for Standardization (ISO) requirements for grading 1D and 2D label-based barcodes. The included calibration card and robust grading algorithms ensure that the DataMan 475 conforms to ISO and application standards while providing accurate and repeatable results.

The DataMan 475 verifiers are packaged in a rugged, IP65-rated housing, and provide numerous ease-of-use features, including one button to trigger and one button to start tuning.

Supportive Documentation

Configuration

This document provides basic information about how to configure and use the DataMan 475 verifier. Additional information is available through the Windows **Start** menu or the DataMan Setup Tool **Help** menu once installing the DataMan software on your PC:

- The ***DataMan Communications and Programming Guide*** shows you how to integrate your DataMan reader into your particular automation and factory environment.

Cognex->DataMan Software v x.x.x->Documentation->Communications->DataMan Communications and Programming Guide







- The **DataMan Industrial Protocols Manual** provides information on how to integrate DataMan readers into your particular environment using industrial protocols.
Cognex->DataMan Software v x.x.x->Documentation->Communications->DataMan Industrial Protocols Manual
- The **DataMan Reader Configuration Codes** document provides printable 2-D codes that you can use to configure the DataMan reader.
Cognex->DataMan Software v x.x.x->Documentation->English->Reader Configuration Codes
- The **DataMan 475 Verifier Quick Reference Guide** provides essential information about the DataMan 475 Verifier.
Cognex->DataMan Software v x.x.x->Documentation->English->DM475V Series->DM475V Quick Reference Guide
- The **DataMan Fixed-Mount Readers Reference** is a complete online hardware reference for the DataMan fixed-mount ID readers.
Cognex->DataMan Software v x.x.x->Documentation->English->DM475V ->Fixed-Mount Reference Manual
- The **Setup Tool Reference Manual** describes the user interface of the DataMan Setup Tool software.
Cognex->DataMan Software v x.x.x->Documentation->English->Setup Tool Reference Manual
- The **Release Notes** list detailed system requirements and additional information about this DataMan software release.
Cognex->DataMan Software v x.x.x->Documentation->DataMan v x.x.x Release Notes

DataMan 475 Verifier Accessories



Note: For ISO compliant verification, equip the DM475V with LabelLight 45° lighting accessory (DMV-475V-LBL-0200). Use other light accessories for DM475V for Standards Based Grading only.

Note: The product images below serve illustration purposes only. You can purchase the following components separately. For a list of options and accessories, contact your local Cognex sales representative.

Cables and Power Supply

Accessory Name	Accessory Product Number	Accessory Illustration
Power and I/O breakout cable, M12-12, straight, xx specifies length: 5 m, 10 m, 15 m, angled, xx specifies length: 5 m, 10 m, 15 m	CCB-PWRIO-xx CCB-PWRIO-xxR	
X-Coded to A-Coded Ethernet cable adapter, 0.5 m	CCB-M12X8MS-XCAC	
X-Coded to RJ45 Ethernet cable, xx specifies length: 2 m, 5 m, 15 m, 30 m	CCB-84901-2001-xx	
I/O extension cable, straight, 5 m	CKR-200-CBL-EXT	
Connection module (up to 4 cameras including network switch) xx can be US, EU, UK or JP	DMA-CCM-4X-xx	
Connection module (1 camera) xx can be US, EU, UK or JP	DMA-CCM-1-xx	

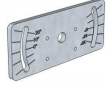
Mounting Brackets

Accessory Name	Accessory Product Number	Accessory Illustration
Mounting Bracket Kit	DMBK-470-MNT	
Pivot Mounting Bracket	DM100-PIVOTM-00	
External Heat Sink	DMHS-370-470	

DataMan 475 Verifier Systems

	Symbologies	Light Configurations	Verification Standards
DMV-475V-LBL-0200	1D, 2D, DPM	45° LabelLight	ISO/IEC 15415, 15416, 29158

Setting Up Your DataMan 475 Verifier

This section provides information on the physical appearance of the DataMan 475 verifier. It also details the steps of installing the lenses and filters of the verifier, and gives information on the imager.

Reader Layout

The following image shows the lighting system of the DataMan 475 verifier and the mounting holes underneath the plastic lighting cover.

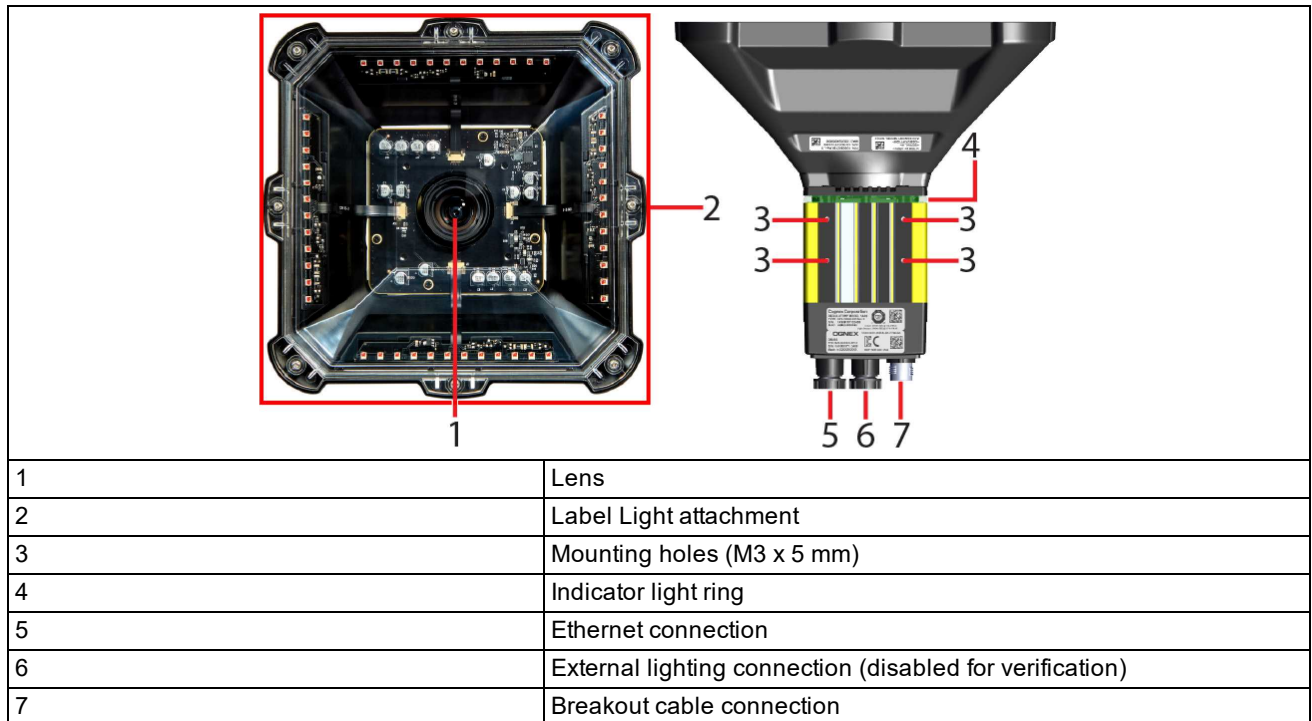

The image shows the back cover of the DM475V and the functions of the indicator lights.

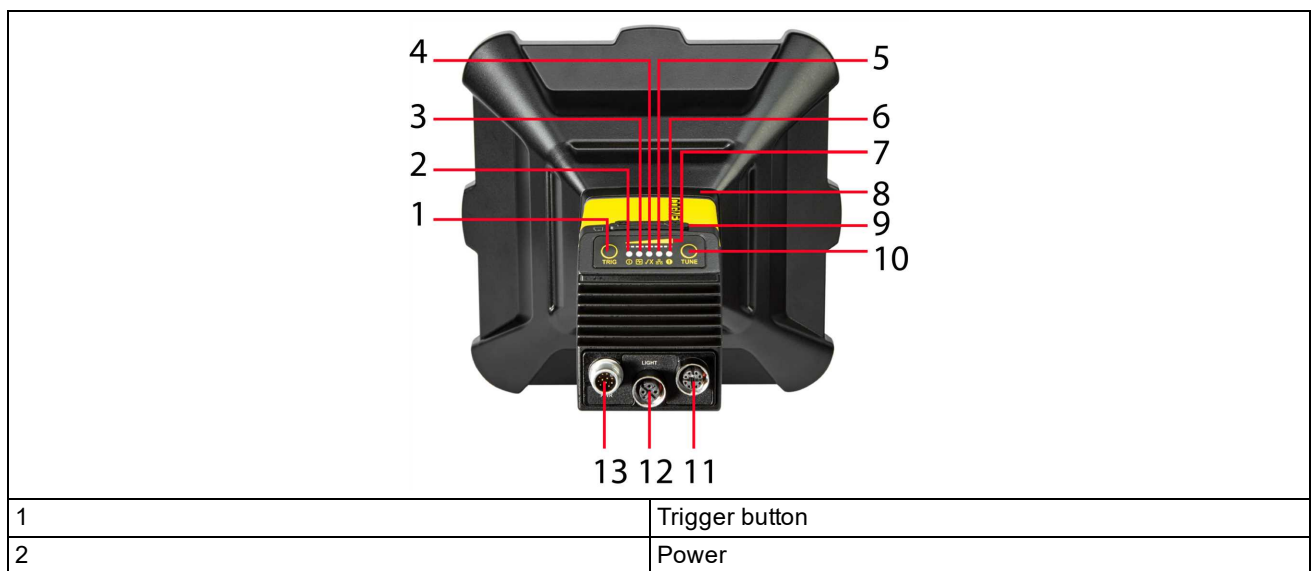

3	Train status
4	Good/bad read
5	Network
6	Error
7	Peak meter
8	Indicator light ring
9	SD card slot
10	Tuning button
11	Ethernet
12	External light control
13	Power, I/O, and RS-232

The table explains the indicator light ring behavior.

Type	Signal	Color	Meaning
Status	Power	GREEN	Power ON
	Train status	GREEN	Trained
		YELLOW	Untrained
	Error	RED	Error - check device log
Action	Good/bad read	GREEN	Good read
		RED	Bad read
	Communication	YELLOW	Link up
		<i>blink</i>	Activity
	Peak meter	-	Decode yield, train progress/quality

Dimensions

Note:



- Dimensions are in millimeters [inches] and are for reference purposes only.
- All specifications are for reference purposes only and can change without notice.

Observe the following DataMan 475 verifier dimensions when installing your reader.

DataMan 475 Verifier

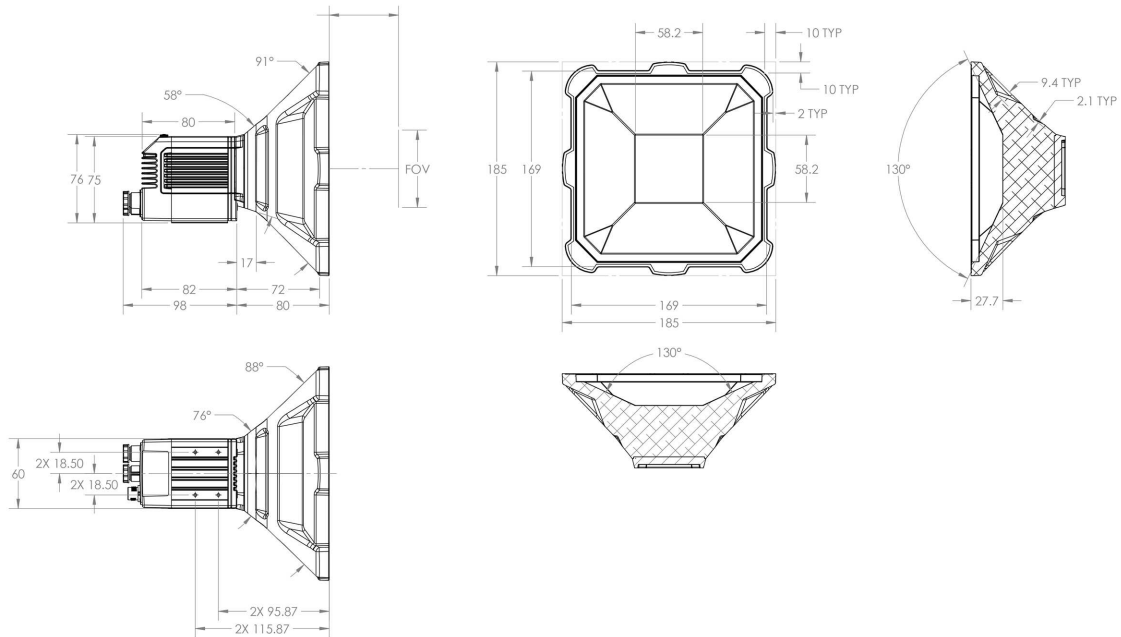

Additional Information

DataMan 475 Verifier Specifications

Specification	DataMan 475 Verifier
Weight	945 g
Field of View	80 x 60 mm
Dimensions	185 x 185 x 175 mm
Power Consumption	<ul style="list-style-type: none"> 24 VDC \pm10%, 1.5 A maximum (Label Light, 36 W peak power consumption) Supplied by LPS or NEC class 2 only.
Light Connector	0.4 A
	Note: The Light Connector is disabled while the Label Light accessory is in place.
Case Temperature ¹	0 °C - 57 °C (32 °F - 134.6 °F)

¹ Additional cooling measures may be required to keep the case temperature from exceeding 50 °C. Examples of such measures include: extra heat sinking and/or air movement.

Specification	DataMan 475 Verifier																								
Operating Temperature ¹	0 °C - 40 °C (32 °F - 104 °F)																								
Storage Temperature	-20 °C - 80 °C (-4 °F - 176 °F)																								
Humidity	< 95% non-condensing																								
Environmental	IP65 with cables attached.																								
Shock (Shipping and Storage)	IEC 60068-2-27: 18 shocks (3 shocks in each polarity in each (X, Y, Z) axis) 80 Gs (800 m/s ² at 11 ms, half-sinusoidal) with cables or cable plugs and appropriate lens cover attached.																								
Vibration (Shipping and Storage)	IEC 60068-2-6: vibration test in each of the three main axis for 2 hours @ 10 Gs (10 to 500 Hz at 100 m/s ² / 15 mm) with cables or cable plugs and appropriate lens cover attached.																								
Supported Symbologies	1D codes: Codabar, Code 39, Code 128, and Code 93, Interleaved 2 of 5, UPC/EAN/JAN 2D codes: Data Matrix (ECC 200), QR Code, microQR Code Stacked codes: PDF 417																								
Discrete I/O operating limits	<table border="0"> <tr> <td>HS Output 0,1,2,3</td> <td>I_{MAX}</td> <td></td> <td>50 mA</td> </tr> <tr> <td></td> <td>R_{MIN}</td> <td>@ 12 VDC</td> <td>200 Ω</td> </tr> <tr> <td>Input 0 (Trigger)</td> <td>V_{IH}</td> <td>± 15 — ± 28 V</td> <td></td> </tr> <tr> <td>Input 1,2,3</td> <td>V_{IL}</td> <td>0 — ± 5 V</td> <td></td> </tr> <tr> <td></td> <td>I_{TYP}</td> <td>@ 12 VDC</td> <td>2.0 mA</td> </tr> <tr> <td></td> <td></td> <td>@ 24 VDC</td> <td>4.2 mA</td> </tr> </table>	HS Output 0,1,2,3	I_{MAX}		50 mA		R_{MIN}	@ 12 VDC	200 Ω	Input 0 (Trigger)	V_{IH}	± 15 — ± 28 V		Input 1,2,3	V_{IL}	0 — ± 5 V			I_{TYP}	@ 12 VDC	2.0 mA			@ 24 VDC	4.2 mA
HS Output 0,1,2,3	I_{MAX}		50 mA																						
	R_{MIN}	@ 12 VDC	200 Ω																						
Input 0 (Trigger)	V_{IH}	± 15 — ± 28 V																							
Input 1,2,3	V_{IL}	0 — ± 5 V																							
	I_{TYP}	@ 12 VDC	2.0 mA																						
		@ 24 VDC	4.2 mA																						
Ethernet Speed	10/100/1000																								

DataMan 475 Series Verifier Imager Specifications

Specification	DataMan 475 Imager
Image Sensor	2/3 inch CMOS, global shutter
Image Sensor Properties	8.8 mm x 6.6 mm (H x V); 3.45 μ m square pixels
Image Resolution (pixels)	2448 x 2048
Electronic Shutter Speed	Fixed at 30 μ s for ISO 15415 compliance. Auto adjusted exposure for ISO 29158 (AIM-DPM) compliance. Note: If the user adjusts the shutter speed, there is no guarantee that the verifier retains compliance.
Image Acquisition at Full Resolution	37 Hz for imager without lighting. Note: Max. acquisition speed with 45 lighting degree accessory enabled is significantly less. Practical acquisition rate is application dependent.

LED Wavelengths

The following table shows LED types and the related peak wavelengths:

LED	λ [nm]
RED	660

¹ In situations where the operating temperature exceeds 40 °C, an external heat sink is required.

Calibration

Calibration informs the verifier about the grey scale levels and pixel dimensions of the reader. This way, the verifier can report Symbol Contrast and X-dimension in true physical units.

For ISO compliant barcode verification, make sure that the verifier is in a calibrated state.

For Standards Based Grading, the verifier will not report all quality parameters without calibration.

In an uncalibrated state the verifier does not report:

- Aperture and Symbol Contrast (SC) for ISO/IEC 15415/15416 applications
- Minimum Reflectance (MR) for ISO/IEC TR29158 (AIM-DPM) applications

When the verifier is used in an uncalibrated state, neither the aperture nor Symbol Contrast (SC) for ISO/IEC 15415/15416 applications and Minimum Reflectance (MR) for ISO/IEC TR29158 (AIM-DPM) applications is reported.

Note: In an uncalibrated state, the verifier does not report aperture value, but uses the default aperture selection: Auto 80%.

To calibrate the DataMan 475:

1. Click the **Calibration** icon in the top left corner in the TruCheck Verification window.



2. Enter the **Rmax** and **Rmin** values from the calibration card.

TruCheck Calibration

COGNEX

1. Please enter the RMax and RMin values for the Master Grade symbol

2. Click Center Target or pull and release handheld trigger to display a live view of the Master Grade Symbol

3. After centering symbol, pull and release handheld trigger or click below to begin calibration

RMax RMin

3. Click **Center Target**.

4. A live image appears in the Calibration screen. Center the verifier over the Master Symbol on the Data Matrix symbol of your traceable calibration card.
5. Click **Start Calibration**.

6. The verifier goes through a series of lighting calibrations. After a successful calibration, the **Calibration Complete** window pops up:

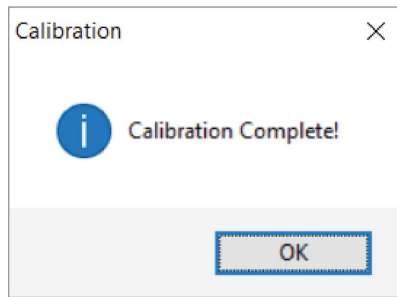

 **Tip:** Click **Discard Calibration** to remove all calibration values and return the verifier to an uncalibrated state.

Calibrate your verifier as needed to ensure accurate verification results:

- Monthly calibration recommended: for laboratory or QA environment, which is free of dust, vibration, bright sunlight or oil particulates
- Weekly calibration is recommended: for production environments, where contaminants exist
- Custom frequency calibration recommended: where internal quality guidelines demand more frequent calibration

 **Note:** Store the calibration card away from direct light where contaminants do not compromise the calibration symbol.



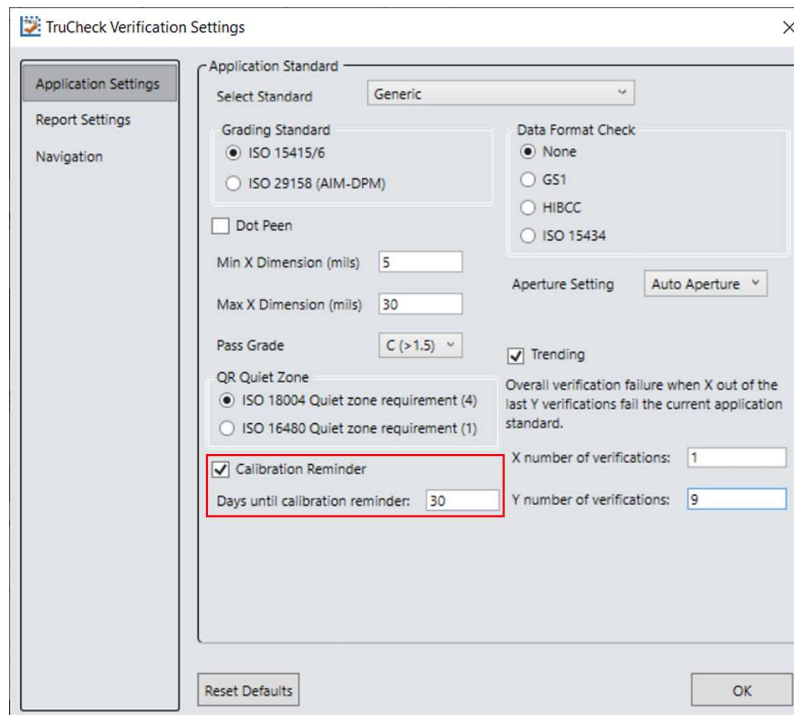

 **Tip:** Enable a calibration reminder to alert you about the next scheduled calibration. After enabling the calibration reminder, set the number of days for prompting a calibration reminder.



User Interface

This section describes the settings and options of the TruCheck Verification window.

Toolbar

Icon	Function
	<p>Settings: Opens up the settings menu allowing changes in the Application Settings, the Reporting Settings and the User Information menu. For more information, see Settings on page 28.</p>
	<p>Calibration: Opens up the calibration window to calibrate the unit. For more information, see Calibration on page 13.</p>
	<p>Grid & Modulation Circles: When selected, this applies a grid and/or modulation circle to the image after verification. Use the drop-down menu to apply a Real Grid, an Ideal Grid, or both. Select one of the options to either show Mod Circles Filled or Mod Circles Outlined.</p>
	<p>Original Image: Shows the image as acquired by imager before post processing.</p>
	<p>45° illumination: Enables 45° illumination. 45° four-sided illumination is used primarily for labels. This illumination is either not reported or reported as 45Q. (If illumination is not reported, it is assumed to be 45Q).</p>

Using Your DataMan 475 Verifier

Verifying a 2D Barcode

To verify a Data Matrix code or a QR code in the TruCheck Verification Window:

1. Navigate to the **Main** tab.
2. Click **Go Live** and center your symbol in the field of view, or press and release the trigger button to **Go Live**.

Note: After selecting **Go Live**, the button changes to **Verify**.

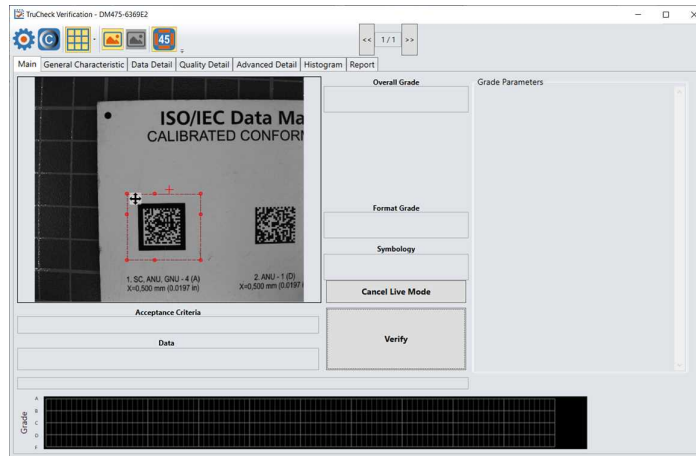

3. Draw a selection region around the code to be verified, if necessary.

Note: The region must be drawn around the outside perimeter of the code including quiet zones. More information on properly defining regions is explained in [Selecting Regions on page 18](#).

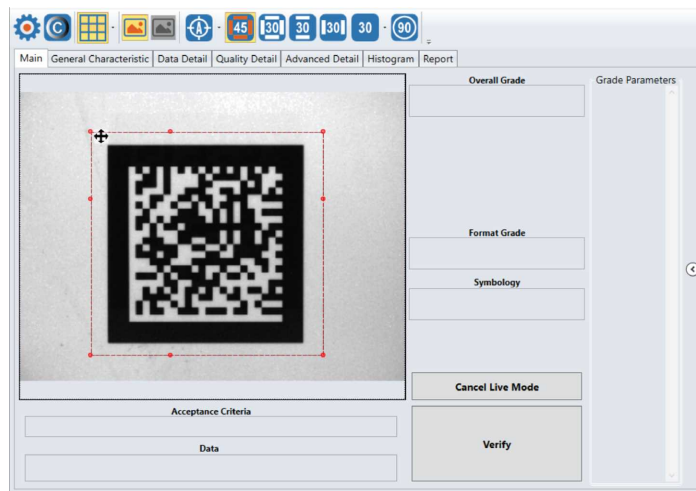

4. Click **Verify**, or press and release the trigger button on the verifier to begin verification.

Note: The following screenshot shows a successful 2D barcode verification. Additional details in the TruCheck window are displayed depending on grading and application standards.

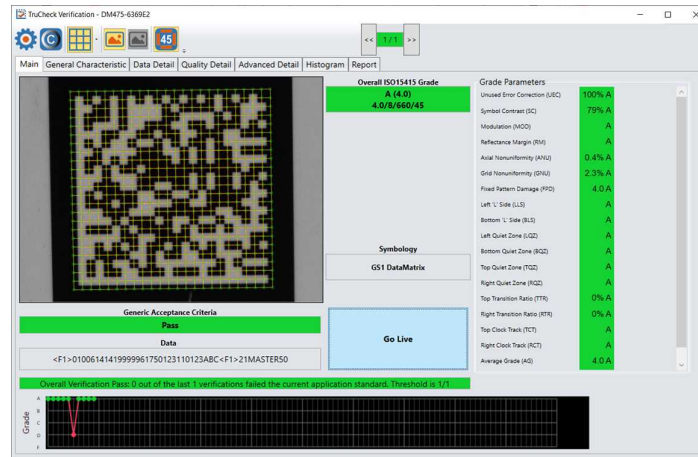

Note: Use the tool bar buttons and tabs on the screen for in-depth analysis of codes. For more information, see [Examining the Results on page 21](#).

Selecting Regions

Requirements for specifying regions on the image are the following:

- The code is off-center.
- To speed up the verification process on verifiers with large fields of view. Defining a small sampling area increases the speed.
- To restrict a region for image brightness adjustments when grading according to AIM-DPM (ISO/IEC 29158).
- To specify a barcode for verification when more than one barcode is present in the field of view.

If you do not define a region, the whole image is used for verification.

To define a region:

1. Position your cursor where you want the region to start, click and drag.
2. Release the button when you are done.

For Data Matrix symbols and QR Codes, draw the region around the outside perimeter including quiet zones of the code to capture the entire finder pattern within the selection to properly grade the code.

When verifying a 1D symbol, select a region that includes the full width of the barcode including both quiet zones:

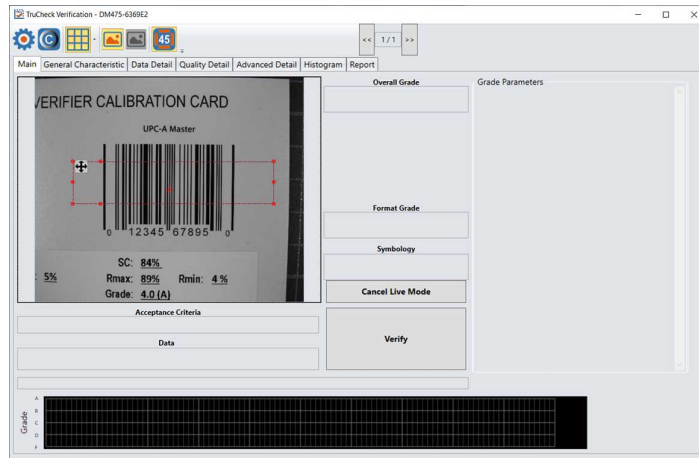

Standards Based Grading

Standards based grading is an option in the DM475V that uses true verification algorithms to produce well-defined, consistent results from the image of a code captured by a barcode reader in a real-world setup. In practice, the setup needs to be as close as possible to a fully ISO compliant verifier – lighting angle in particular. The measurements are calculated the same way as with a verifier, so the closer the setup is to a true verifier, the closer the results are to true verification. With the same lighting setup, the measurements between standards based grading and verification converge. This method is called standards based grading because as the quality of a code changes during a production run, grades change in about the same way as with a verifier. Standards based grading is the closest way to achieve verification results without having to conform to specific lighting angles, distances, or every ISO standard parameter.

For Standards Based Grading, the verifier can be used without calibration but not all quality parameters are reported. When the verifier is used in an uncalibrated state, neither the aperture nor Symbol Contrast (SC) for ISO/IEC 15415/15416 applications and Minimum Reflectance (MR) for ISO/IEC TR29158 (AIM-DPM) applications is reported.

Note: In an uncalibrated state, the verifier does not report aperture value, but uses the default aperture selection: Auto 80%.

Verifications of Multiple Symbols

To enable multiple barcode verification feature, complete the steps below in DataMan Setup Tool before initiating verification in the TruCheck window.

1. Open DataMan Setup Tool.
2. To connect to the DM475 Verifier double click on the icon in the automatically generated list on the **Start up** page.

Note: Refer to DataMan Setup Tool Reference manuals if you have trouble connecting.

3. Select **Code Details** from the **Application Steps** in Setup Tool.

- Under the **Basic** tab, change the **Number of Codes** field to a value greater than 1 to see the expanded list of options available.

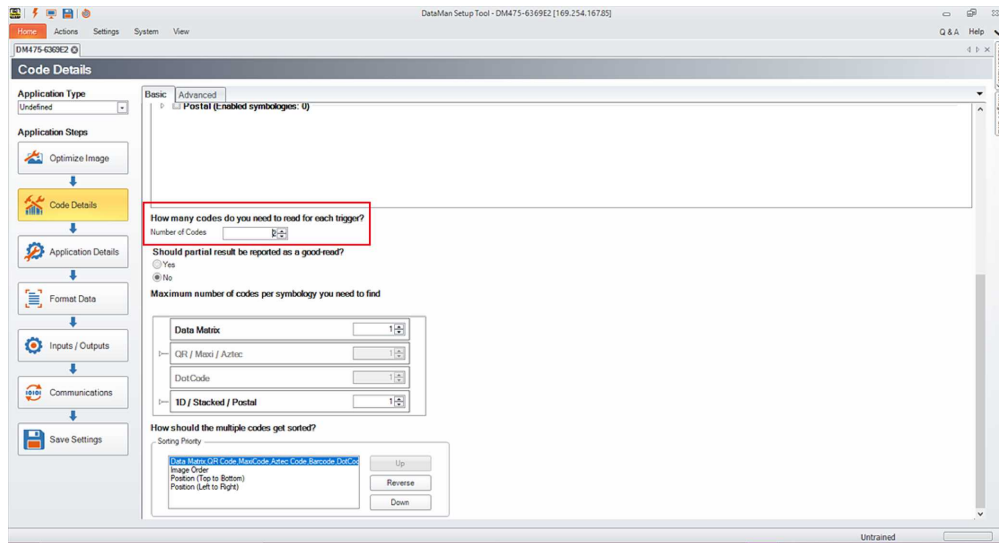

- Select the **Number of Codes** to be verified during a single trigger.
- For **Should partial result be reported as a good read?** select **No**.

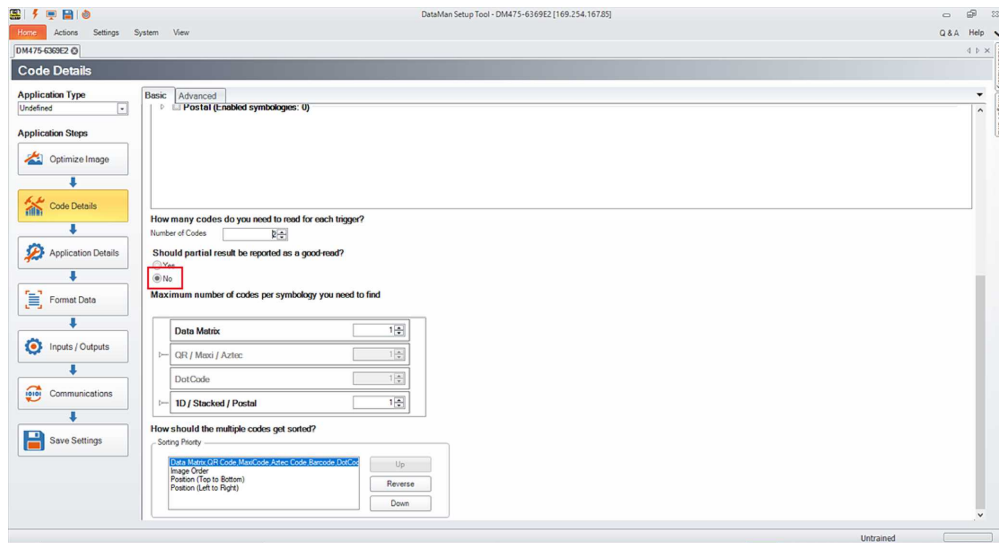

- Select the quantity of each symbology type to be verified in a single trigger under **Maximum number of codes per symbology you need to find**.
- Select the appropriate **Sorting Priority**.
- Open the TruCheck window and initiate a verification.
For multiple verifications, select either a single region to identify all symbols for verification, or the entire field of view.

See the individual results in the tabs with the help of the arrows at the top of the TruCheck verification window, following the successful verification of multiple symbols. If all verifications pass, the box is green. If any verification fails, the box is red.



Saved Code Quality reports include an appended report containing individual result for each verified barcode.

Examining the Results

This section details how the results of the verification can be viewed and analyzed.

1D & 2D Verification

The following chapters will discuss the user interface of TruCheck Verification. The image below shows the opening window of TruCheck Verification.

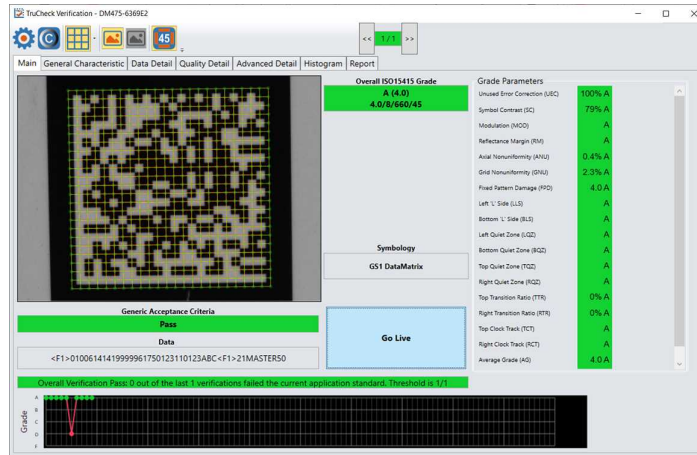

Main Tab

The **Main** tab shows a snapshot of the verification results.

Acceptance Criteria: Provides a Pass or Fail grade for the barcode and is dependent on the **Application Standard** selected. For more information, see [Application Settings on page 28](#).

Data: Shows the decoded data.

Overall Grade: Shows the overall grade results for the barcode as both a letter grade (A) and numeric grade (4.0). A Formal Grade is provided in the format “Grade/Aperture/Wavelength/Lighting”.

For example, a Formal Grade of “4.0/08/660/45” is interpreted as receiving a grade of 4.0 using 8 mil aperture (0.2 mm), 660 nm wavelength, and 45° lighting.

Format Grade: Provides the Format Grade of the barcode and is dependent either on the **Application Standard** or **Data Format Check** criteria selected. For more information, see [Application Settings on page 28](#)

Symbology: The type of symbology the verifier detected and verified.

Grade Parameters: Provides information on the Quality Parameters grading for the barcode. For more information, see [Quality Detail Tab on page 25](#).

Grade Trending:

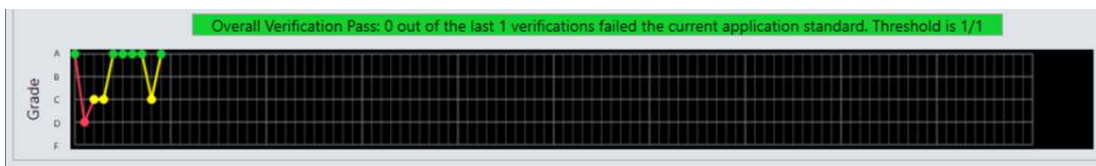

The TruCheck window shows the grade trending values for symbol verified over time. The graph at the bottom of the **Main** window shows data points associated with the overall grade for each symbol verified. The grade trending reports the data point for each Overall Grade.

In verifications where a symbol passes all quality parameters but fails the acceptance criteria for another reason such as data parsing error or x-dimension range, the grade is shown as an F. For example, if a symbol receives an overall grade of A (4.0) but fails for an X-dimension out of range, grade trending marks the data point as an F.

1. Enable or disable **Grade Trending** using the **Trending** checkbox in the **Application Settings** menu.
2. Set a tolerance range for the number of verifications (x) allowed to fail out of the total number of verifications (y) specified.

If the trending point falls below the specified threshold, trending is reported as an Overall Verification Failure. The Pass Grade value set in the **Application Settings** menu determines if a symbol is considered a pass or fail for Grade Trending purposes. Grade Trending does not show data points for verifications that result in a NO DECODE evaluation.

Note: Grade Trending data points remain populated and continue to trend on the **Main** window until the power is disconnected from the verifier.

General Characteristics Tab

General Characteristic: shows the physical characteristics of the verified barcode.

The image shows the characteristics of a Data Matrix barcode:

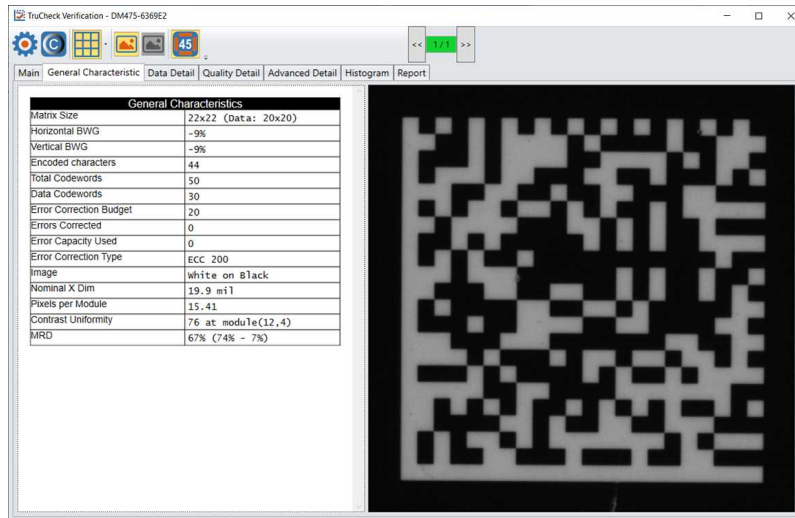

Contrast Uniformity : verifies conformance with ISO/IEC 15426-2 as shown in the **General Characteristics** tab. Some of the contents of this screen depend on the symbology and settings on the **Report Settings** menu. For more information, see

The image shows the characteristics of a 1D barcode:

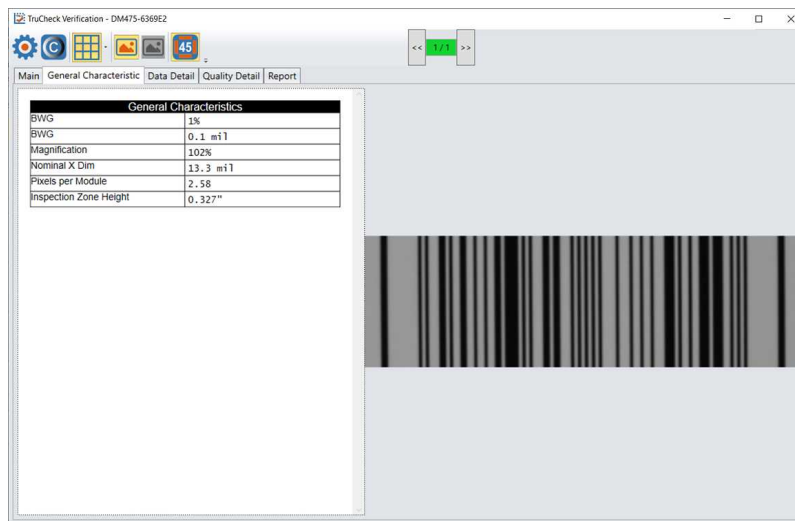

Data Detail Tab

The **Data Detail** tab shows all of the data encoded in the symbology in various ways, and makes the understanding of the the symbology easier. The versatile interpretation of the symbology is especially helpful when the data is encoded incorrectly. The level of detail depends on the symbology and the selected **Application Standards**.

The image shows a Data Matrix with encoding information with a depiction of the symbol to the right showing each module:

The screenshot shows the TruCheck Verification software interface. The main window displays a Data Matrix symbol and its decoded data. The Data section shows a long string of characters. The Unicode Data section shows the same data interpreted as Unicode characters. The ASCII Values section shows the decimal values for each character. The Codewords section lists the raw codewords and their corresponding ASCII values. The Encodation Analysis section shows the conversion of raw codewords into decoded ASCII values using various methods.

The **Data Detail** tab contains:

- Data,
- Unicode Data
- ASCII Values
- Codewords (if applicable)
- Encodation Analysis (if applicable)

Data Parameter	Content
Data	Data refers to the data decoded from the symbology in normal, printable characters.
Unicode Data	Unicode Data shows the data interpreted as Unicode characters. The characters are the same as the characters in Data section, except when the data in the symbology encodes non-latin characters, such as Kanji, using Unicode encodation.
ASCII Values	ASCII Values gives ASCII value of each decoded character. ASCII values are helpful in case an unprintable character is encoded in the symbology and you need to confirm that the character is correct. For example, by looking at the ASCII values table you can see that a <GS> in the decoded data is actually the ASCII character with decimal value of 29, and not the four characters: “less than”, G, S, “greater than”.
Codewords	Codewords section lists the values of the raw codewords encoded in the symbology, including the error correction codewords. An asterisk (*) denotes codewords which were decoded incorrectly and determined through error correction decoding.
Encodation Analysis	Encodation Analysis section shows the detailed conversion of raw codewords, into decoded ASCII values using the encodation and compression methods defined for the symbology. For example, in Data Matrix an encodation method known as C40, encodes 3 ASCII characters in only two codewords. Similarly, PDF417 and other 2D symbologies have various methods of encoding different types of data (such as numeric only data) in efficient ways. The encodation analysis table can show you the process of this encodation/decode.

When a data checking failure occurs, a message indicates the cause of the failure.

For example, if a check digit is incorrect, a message indicates the expected check digit value. When an error is detected, it is reported and the parsing is stopped.

When the cursor hovers over the codewords in the Data Matrix **Codeword table**, the modules constituting the 8-bit codeword are highlighted within the image to show where the data is encoded within a Data Matrix symbol.

Quality Detail Tab

The **Quality Detail** tab shows the measured quality parameters and lists the formal grade. Different symbologies and quality grading standards display pertinent data here.

Characteristics of a 2D Data Matrix code graded according to ISO 15415:

TruCheck Verification - DM475-6369E2

Main | General Characteristic | Data Detail | **Quality Detail** | Advanced Detail | Histogram | Report

Verification Grade				
Overall	Aperture	Wavelength	Lighting	Formal
A (4.0)	16	650	45	4.0/16/650/45

ISO15415 Quality Parameters				
1. Unused Error Correction (UEC)	A	100%		PASS
2. Symbol Contrast (SC)	A	80%	RiRd (84/3)	PASS
3a. Modulation (MOD)	A			PASS
3b. Reflectance Margin (RM)	A			PASS
4. Axial Nonuniformity (ANU)	A	0.1%		PASS
5. Grid Nonuniformity (GNU)	A	3.1%		PASS
6. Fixed Pattern Damage (FPD)	A	4.0		PASS
7. Left 'L' Side (LLS)	A			PASS
8. Bottom 'L' Side (BLS)	A			PASS
9. Left Quiet Zone (LQZ)	A			PASS
10. Bottom Quiet Zone (BQZ)	A			PASS
11. Top Quiet Zone (TQZ)	A			PASS
12. Right Quiet Zone (RQZ)	A			PASS
13. Top Transition Ratio (TR)	A	0%		PASS
14. Right Transition Ratio (RTR)	A	0%		PASS
15. Top Clock Track (TCT)	A			PASS
16. Right Clock Track (RCT)	A			PASS
17. Average Grade (AG)	A	4.0		PASS
18. DECODE	A			PASS

Characteristics of a 1D UPC-A symbol graded according to ISO 15416:

TruCheck Verification - DM475-6369E2

Main | General Characteristic | Data Detail | **Quality Detail** | Report

Verification Grade				
Overall	Aperture	Wavelength	Lighting	Formal
B (3.2)	11	650	45	3.2/11/650/45

ISO15416 Quality Parameters				
1. Edge	A	59		PASS
2. Reflectance Light / Reflectance Dark (RiRd)	A	79/4		PASS
3. Symbol Contrast (SC)	A	75%		PASS
4. Minimum Edge Contrast (MinEC)	A	80%		PASS
5. Modulation (MOD)	A	90%		PASS
6. Defect (DEF)	A	0%		PASS
7. Decode (DCC)	A	10/10		PASS
8. Decodability (DEC)	B	52%		PASS
9. Minimum Quiet Zone (MinQZ)	A	9		PASS

Individual Scan Results									
Scan #	Edge	MinRef	SC	MinEC	MOD	DEF	DECODE	DEC	QZ
1	A	A	A	A	A	A	A	A	A
2	A	A	A	A	A	A	A	A	A
3	A	A	A	A	A	A	A	B	A
4	A	A	A	A	A	A	A	B	A
5	A	A	A	A	A	A	A	B	A
6	A	A	A	A	A	A	A	B	A
7	A	A	A	A	A	A	A	B	A
8	A	A	A	A	A	A	A	B	A
9	A	A	A	A	A	A	A	B	A
10	A	A	A	A	A	A	A	B	A

For more information on grading standards, see [Grading Standards and their Parameters on page 42](#).

Advanced Detail Tab

The **Advanced Detail** tab shows in-depth information on the verified code. Depending on the type of the verified 1-D or 2-D code, information on the **Advanced Detail** tab may vary.

The example shows the modulation values from a Data Matrix symbol:

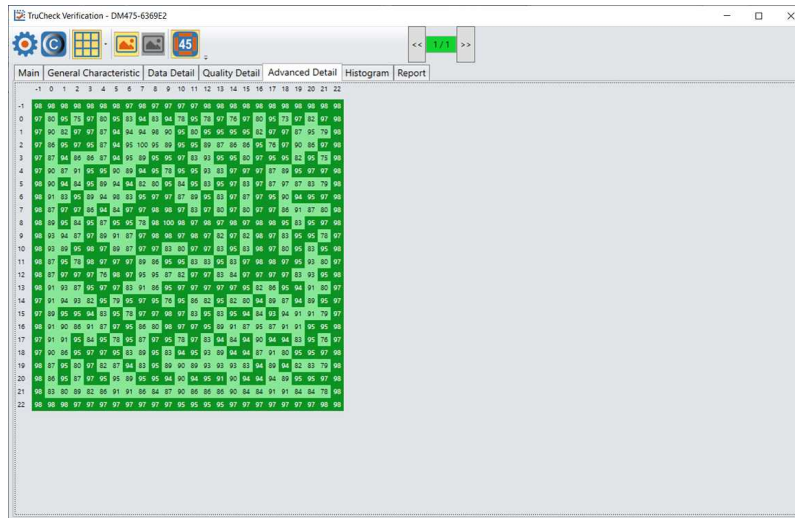

For more information on modulation calculation, see [Grading Standards and their Parameters on page 42](#).

Histogram Tab

The **Histogram** tab shows the analysis of the reflectivity of each cell and associated grade.

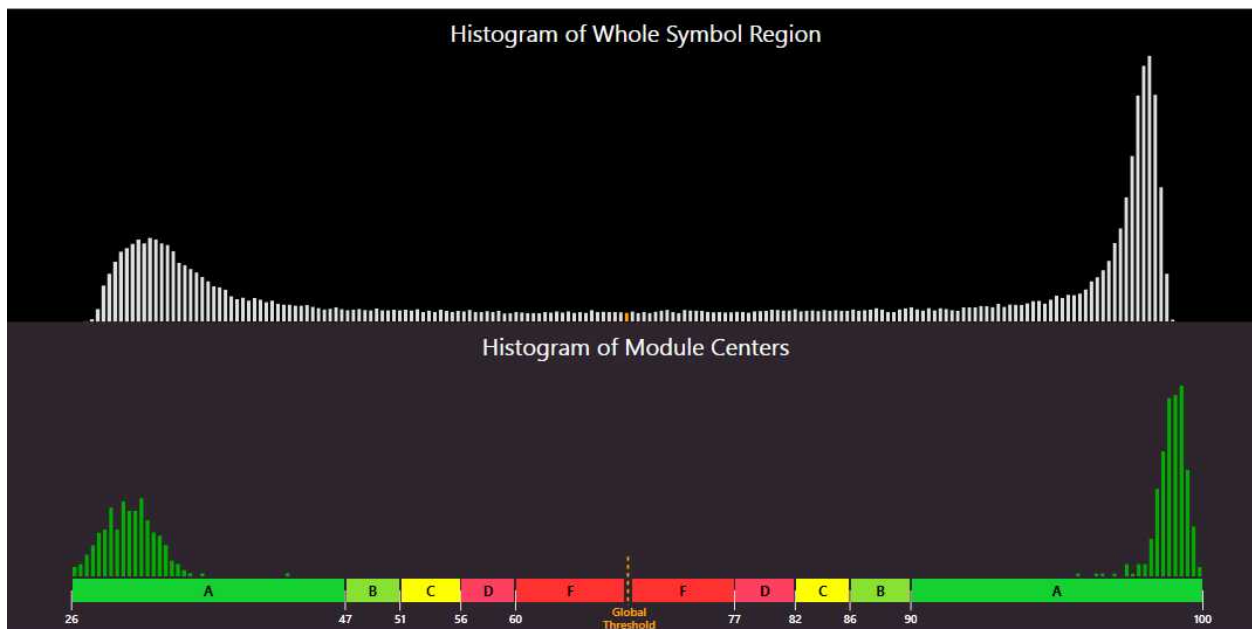

The horizontal axis on the Histogram represents the brightness level with the dark elements on the left side and the bright elements on the right side. The brighter the element is, the histogram displays it farther to the right of the window. The height of each bar represents the number of elements with the same brightness associated with their position on the horizontal axis.

The top graph of the histogram represents the brightness of all the pixels in the image. The bottom graph of the Histogram represents the center of modules in the symbol. The bottom graph only contains elements which are either definitively dark or definitively bright. The bars are grouped together because all the dark or bright modules of varying brightness are close to each other. Pixels with varying brightness are on the border between dark and light modules, therefore they obtain a middle value of brightness.

The horizontal axis contains markers showing the global threshold (tall, orange line), and all modulation levels are separated for both dark and light elements.

Note: When grading according to ISO/IEC TR29158 (AIM-DPM), the histogram is labeled differently. The 0% and 100% labels on the horizontal axis are located at the means of the dark and light lobes of the histogram and there is no C level because the DPM grading method uses only A, B, D and F levels for Cell Modulation.

Report Tab

To enable the Code Quality report to show in the **Report** tab, check the box for **Generate Code Quality reports** in the **Results History** pane of Setup Tool.

Note: Minimize TruCheck window and click Setup Tool window on the taskbar.

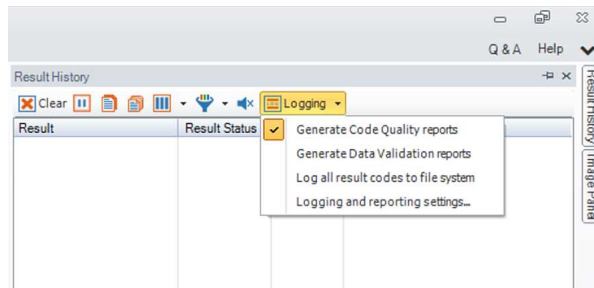

Note: The Code Quality report contains the results specific to verification when the verification feature key is installed and Verification is enabled in the Setup Tool window. The Code Quality report contains the results specific to verification and separate from the previous Code Quality results that Process Control Metrics (PCM) normally generated.

When the **Code Quality report** is enabled, the **Report** tab shows up in the **TruCheck Verification** window showing full verification results formatted into a printable report.

Settings

This section describes the settings you can make and the options you have in the **TruCheck Verification** window.

Accessing the Settings Menu

To access **Settings**, select the **Settings** icon in the upper left hand corner of the **TruCheck Verification** window.

Application Settings

The content of the **Application Settings** window depends on the Application Standard selected, since the application standard setting automatically sets many parameters. The **Generic** application standard allows you to customize all adjustable verification and process parameters. Selecting a pre-defined application standard ensures that the DM475 Verifier uses the appropriate grading parameters for your application. See all pre-defined Application Standards under *Application Standards Settings* chapter.

The **Reset Defaults** button resets the **Application Settings** menu to the default settings (Generic). After clicking **Reset Defaults**, you must calibrate the verifier before using it.

Application Standards Settings

Application Standards configure the verifier to grade according to pre-defined rules established by an industry standards body or other industry requirements.

Select one of the options provided in the drop down box to specify the application standard.

You have the following application standard options:

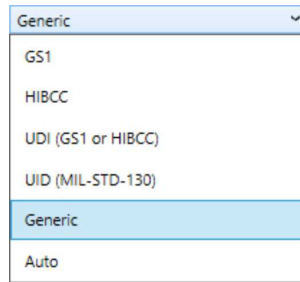

GS1

GS1 application standard follows GS1 General Specification guidelines in code verification. GS1 General Specification Tables 1-11 describe several categories of applications. Select from the tables to specify the application category for your codes. Consider the following examples:

Note: The DM475 Verifier uses the X-dimension of the decoded symbol to deduce which table applies. If your X-dimension is outside of the range allowed in your application, results will be incorrect. To make sure that the verifier checks all the correct requirements for your application, select the Table in the GS1 General Specifications that applies to your application.

The GS1 table used is reported in the **Notes** section of the report. For more information on the tables used for analysis, see [GS1 General Specifications Standard](#).

Specify ISO/IEC 15415 grading method for labels or ISO/IEC 29158 (AIM-DPM) grading method under **Grading Standards** in the **TruCheck Verification** settings window. For more information, see [Grading Standards and their Parameters on page 42](#).

Select **Dot Peen**, if applicable. For more information, see the description of **Dot Peen** under **Data Format Check**.

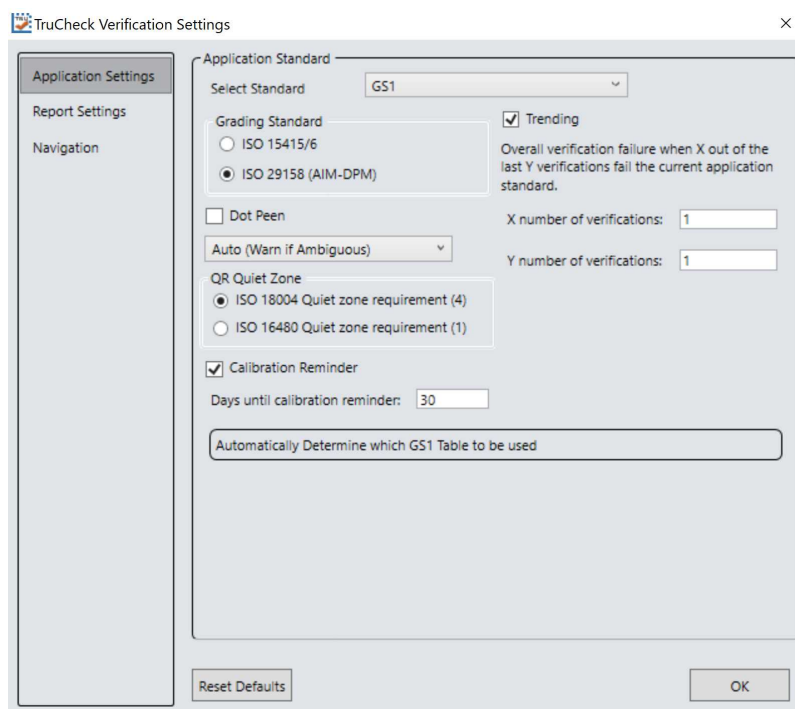

UID (MIL-STD-130)

The UID (MIL-STD-130) application standard reports the quality standard according to the MIL-STD 130 specifying UID marks Construct 1 and Construct 2 that use data structure and code grade for verification. The MIL-STD 130 spells out acceptable grades and requirements for data format.

Specify either the ISO 15415 grading or the ISO 29158 (AIM-DPM) grading for the MIL-STD-130 UID Application Standard. For more information, see [Grading Standards and their Parameters on page 42](#).

Select **Dot Peen**, if applicable. For more information, see the description of **Dot Peen** under **Data Format Check**.

TruCheck Verification Settings

Application Settings

Report Settings

Navigation

Application Standard

Select Standard: UID (MIL-STD-130)

Grading Standard

ISO 15415/6

ISO 29158 (AIM-DPM)

Trending

Overall verification failure when X out of the last Y verifications fail the current application standard.

Dot Peen

X number of verifications: 1

QR Quiet Zone

ISO 18004 Quiet zone requirement (4)

ISO 16480 Quiet zone requirement (1)

Y number of verifications: 1

Calibration Reminder

Days until calibration reminder: 30

Reset Defaults

OK

UDI (GS1 of HIBCC)

The UDI (GS1 of HIBCC) application standard checks symbols that meet UDI requirements using either GS1 or HIBCC guidelines.

Specify the ISO 15415 grading or the ISO 29158 grading. For more information, see [Grading Standards and their Parameters on page 42](#).

Select **Dot Peen**, if applicable. For more information, see the description of **Dot Peen** under **Data Format Check**.

UDI compliance requires data content that varies depending on the medical device the data is applicable to, so the DM475 Verifier only validates the format not the content. Validating data is automatic in accordance with formatting rules of the chosen guidelines.

The screenshot shows the 'TruCheck Verification Settings' dialog box. On the left is a navigation pane with 'Application Settings' selected. The main area is titled 'Application Standard' and contains the following settings:

- Select Standard:** A dropdown menu showing 'UDI (GS1 or HIBCC)'.
- Grading Standard:** Radio buttons for 'ISO 15415/6' and 'ISO 29158 (AIM-DPM)'. 'ISO 29158 (AIM-DPM)' is selected.
- Dot Peen:** An unchecked checkbox.
- QR Quiet Zone:** Radio buttons for 'ISO 18004 Quiet zone requirement (4)' and 'ISO 16480 Quiet zone requirement (1)'. 'ISO 18004 Quiet zone requirement (4)' is selected.
- Calibration Reminder:** A checked checkbox with a text input field for 'Days until calibration reminder' set to '30'.
- Trending:** A checked checkbox.
- Overall verification failure when X out of the last Y verifications fail the current application standard:** A text area with 'X number of verifications: 1' and 'Y number of verifications: 1'.

At the bottom are 'Reset Defaults' and 'OK' buttons.

Generic

Apply the **Generic** standard option when you are grading a code that is not expected to adhere to any pre-defined industry conformance standard, and so it can be customized with specific settings for:

- Grading Standard: ISO 15415 or ISO 29158, for more information, see [Grading Standards and their Parameters on page 42](#).
- Minimum and Maximum X-dimension
- Minimum Acceptable Pass Grade
- Data Format Check
- Aperture Size

The screenshot shows the 'TruCheck Verification Settings' dialog box with the 'Generic' standard selected. The settings are as follows:

- Select Standard:** A dropdown menu showing 'Generic'.
- Grading Standard:** Radio buttons for 'ISO 15415/6' and 'ISO 29158 (AIM-DPM)'. 'ISO 29158 (AIM-DPM)' is selected.
- Dot Peen:** An unchecked checkbox.
- Min X Dimension (mils):** A text input field set to '5'.
- Max X Dimension (mils):** A text input field set to '30'.
- Pass Grade:** A dropdown menu showing 'C (>1.5)'.
- QR Quiet Zone:** Radio buttons for 'ISO 18004 Quiet zone requirement (4)' and 'ISO 16480 Quiet zone requirement (1)'. 'ISO 18004 Quiet zone requirement (4)' is selected.
- Data Format Check:** Radio buttons for 'None', 'GS1', 'HIBCC', and 'ISO 15434'. 'None' is selected.
- Aperture Setting:** A dropdown menu showing 'Auto Aperture'.
- Calibration Reminder:** A checked checkbox with a text input field for 'Days until calibration reminder' set to '30'.
- Trending:** A checked checkbox.
- Overall verification failure when X out of the last Y verifications fail the current application standard:** A text area with 'X number of verifications: 1' and 'Y number of verifications: 1'.

At the bottom are 'Reset Defaults' and 'OK' buttons.

Auto

Apply the **Auto** application standard option to allow the verifier to select the correct application standard based on the format of the data encoded in the symbology. If the verifier detects GS1, HIBCC or MIL-STD 130 standards within a symbology during verification, the verifier uses the correct application standard.

Note: Select the **Generic** application standard instead of **Auto** if the symbology contains data structure that the grading of the automatic standards do not apply to.

The screenshot shows the 'TruCheck Verification Settings' dialog box. On the left is a navigation pane with 'Application Settings' selected. The main area is titled 'Application Standard' and contains a dropdown menu set to 'Auto'. Below this is the 'Grading Standard' section with radio buttons for 'ISO 15415/6' (selected) and 'ISO 29158 (AIM-DPM)'. There is also an unchecked checkbox for 'Dot Peen'. To the right of the 'Grading Standard' section is a 'Trending' checkbox which is checked, and a text box explaining: 'Overall verification failure when X out of the last Y verifications fail the current application standard.' Below this are two input fields: 'X number of verifications' and 'Y number of verifications', both set to '1'. At the bottom left of the main area is a 'Calibration Reminder' checkbox which is checked, and a text box for 'Days until calibration reminder' set to '30'. At the bottom of the dialog are 'Reset Defaults' and 'OK' buttons.

Grading Standards

For any Application Standard selected, you must use either ISO 15415 or ISO 29158 (AIM-DPM) depending on your application.

- **ISO 15415:** Used for 2-D label based coder reports and displays verification results according to ISO/IEC 15415.
- **ISO 29158 (AIM-DPM):** With ISO 29158 (AIM-DPM), you can select Dot Peen. When using AIM-DPM Grading, verification uses X-dimension range instead of the aperture setting in accordance with the AIM-DPM methodology.

For more information, visit support.cognex.com, and navigate to Resources > Introduction to Barcode Verification.

Data Format Check

You can apply a specific **Data Format Check** criteria to the data content of the code or leave the option as **None**. If a specific Data Format Check is applied, a **Data Format Check** grading box appears on the main screen of the User Interface to show the Pass or Fail grade. The report contains a Data Format Check table showing detailed parsing information.

- **GS1:** The GS1 option checks the format of the data against GS1 formatting rules. GS1 codes generally begin with a Function 1 <F1> character.
- **HIBCC:** The HIBCC option checks the format of the data against HIBCC formatting rules. HIBCC codes generally begin with a + character.
- **ISO 15434:** The ISO 15434 option checks data for many industry standards which encode information using ISO/IEC 15434 data structures. ISO 15434 codes generally begin with the sequence `]]><RS>nn<GS>` where `nn` are two digits which are typically 05, 06 or 12. MIL-STD-130 and some shipping container applications use this formatting style.

Dot Peen

Use the dot peen option for codes created through a process where dots are peened onto a metal surface. Select **Dot Peen** to use the AIM-DPM Stick algorithm to connect dots.

Min X-Dimension (mils)

Set the minimum x-dimension value. It is not possible to set the value lower than 1 mil. Any code that falls below the minimum x-dimension receives a grade of FAIL (X-Dimension out of Range). If you do not specify a minimum x-dimension, the application defaults to 5 mils.

Max X-Dimension (mils)

Set the highest possible x-dimension value. The highest value that can be set is 100 mils. Any code that is above the maximum x-dimension receives a grade of FAIL (X-Dimension out of Range). If you do not specify a maximum x-dimension, the application defaults to 30 mils.

Pass Grade

Select a minimum passing grade based on a letter and a number (that is, C >1.5). Any verified code that does not receive an Overall Grade above the Pass Grade minimum receives a grade of Fail for Pass Grade on the User Interface and Report.

QR Quiet Zone

Select the ISO 18004 Quiet zone requirements of a 4 module-sized quiet zone or the ISO 16480 Quiet zone requirement of a 1 module-sized quiet zone.

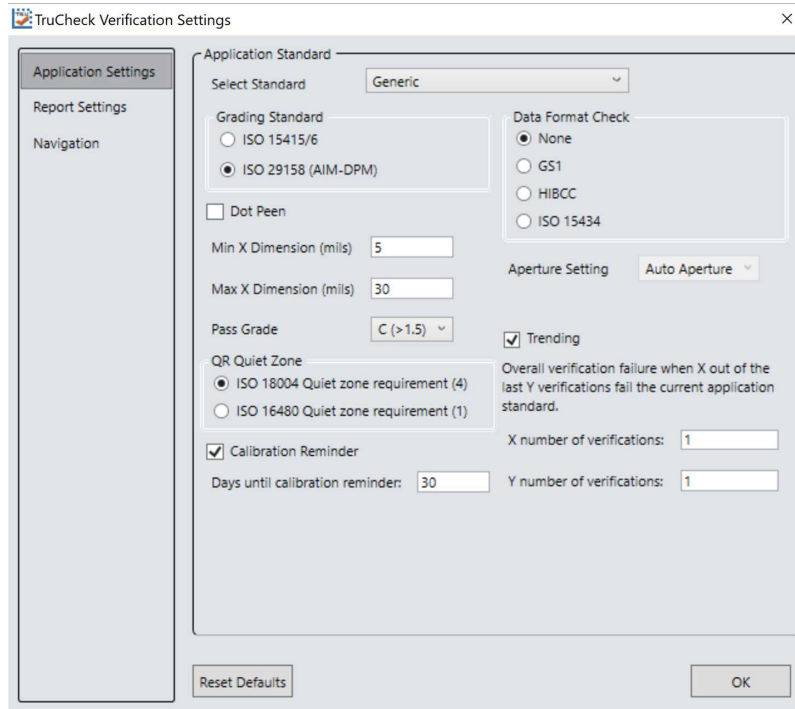

Aperture Setting

Aperture setting refers to a synthetic aperture as opposed to an optical aperture. Aperture is a circular region imposed on the pixels which comprise the individual modules making up the code. This process is mandated by the ISO 15415 and 15416 standards. Set the aperture settings when choosing Generic Application Standards.

Note: Aperture setting must match the Application Standard.

Larger aperture sizes reduce:

- Sensitivity to printing defects
- Ability to resolve small elements in a code

The size of the aperture is limited by the X-dimension of your symbols, or the X-dimension of your symbols is limited by the size of your aperture. Choose aperture size in application specification, Quality specification or both. If you do not know the correct aperture size to select, choose **Auto** and the verifier uses guidance supplied within ISO 15415 to choose an aperture size based on the X-dimension of the code.

Aperture Size setting is compatible with ISO/IEC 15415 only. AIM-DPM grading includes a blurred reference image, similar to ISO 15415. The AIM-DPM grading method dictates the aperture size to be either 50% or 80% of the symbol X-dimension.

Always specify an aperture size for the Generic Application Standard when using ISO/IEC 15415 Grading Standard.

In the drop down menu, select:

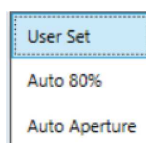

User Set

The application allows you to specify the **Aperture Setting**. If you select **User Set**, an additional drop down menu shows up for you to select the correct aperture.

Aperture Setting	User Set
Aperture Size (mils):	5

Auto Aperture

This chapter describes available automatic aperture settings.

Auto 80%

The application automatically sets an aperture size based on 80% of the X-dimension.

Auto Aperture for 2D Barcodes

The application automatically sets an aperture size based on the X-dimension in accordance with the suggestion in ISO/IEC 15415.

X-Dimension	Aperture
≤ 6 mil	02 (2 mil)
$6 \text{ mil} < x \leq 7.5$ mil	03 (3 mil)
$7.5 \text{ mil} < x \leq 10$ mil	05 (5 mil)
$10 \text{ mil} < x \leq 20$ mil	08 (8 mil)
$20 \text{ mil} < x \leq 30$ mil	16 (16 mil)
≥ 30 mil	20 (20 mil)

Note: AIM-DPM grading (ISO/IEC TR 29158) always selects an aperture automatically based on the X- Dimension of the decoded symbol, which overrides the above rules. These rules only apply to ISO/IEC 15415 grading when **Auto Aperture** is selected.

Auto Aperture for 1D Barcodes

The application automatically sets an aperture size based on the X-dimension in accordance with the suggestion in ISO/IEC 15416. For the Generic Application Standard, the following table applies for most symbologies:

X-Dimension	Aperture
≤ 7.0 mil	03 (3 mil)
$7.1 \text{ mil} < x \leq 13$ mil	05 (5 mil)
$13 \text{ mil} < x \leq 25$ mil	10 (10 mil)
> 25 mil	20 (20 mil)
For UPC/EAN, regardless of X-dimension or magnification	06 (6 mil)

You can override these rules by determining a specific aperture directly for any application that requires a specified aperture. An application specification (such as GS1 Gen Spec, or MIL-STD 129) specifies an aperture value which can be different than what the rules in the table would yield.

Navigation

The **Navigation** menu allows you to access certain options in the Setup Tool window to configure exporting results either through Setup Tool or FTP. The Navigation menu also provides a shortcut to enable or disable symbologies and to set up the verifier to verify multiple symbols in one verification. Click the View button to re-direct Setup Tool to the settings of each reporting option.

Note: Setup Tool must be maximized in order for the shortcuts to work. For more information on Setup Tool Panes, see the *Setup Tool Reference Manual*.

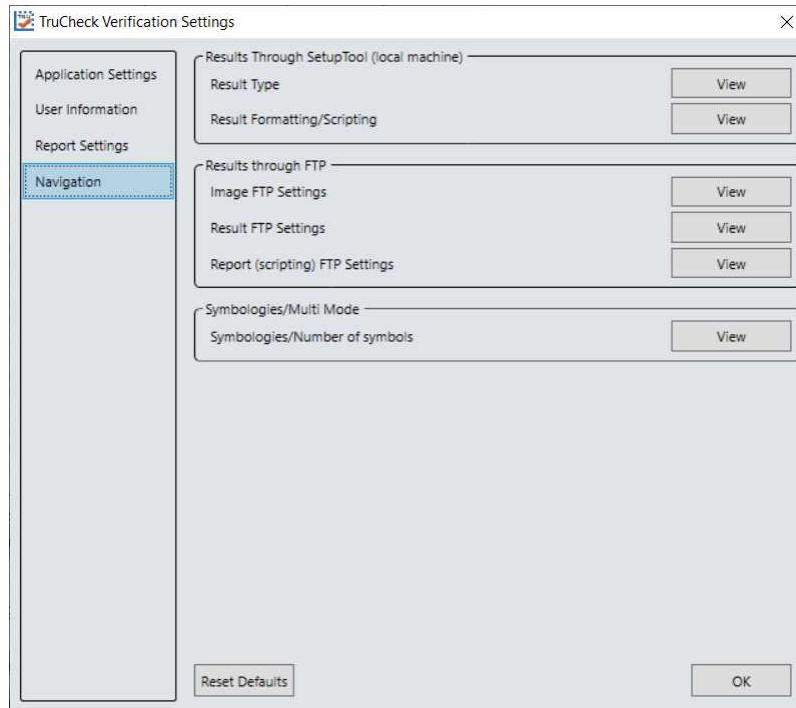

Results through Setup Tool (local machine)

In the Results through Setup Tool (local machine) section, two options are available to navigate to the windows in Setup Tool to set up a scripting menu for exporting verification results either as an HTML or CSV report:

- Result Type
- Result Formatting/Scripting

For more information on the scripting options available for verification, see [Scripting on page 39](#). For more information on broad scripting options available in Setup Tool, refer to the **Scripting** section of the *DataMan Communications & Programming Guide*.

Result Type

Click **Result Type** to open the **Basic** tab in the **Format Data** application step in Setup Tool. Select **Script-Based Formatting** to enable scripting for export of verification data to CSV or to custom, script-defined format.

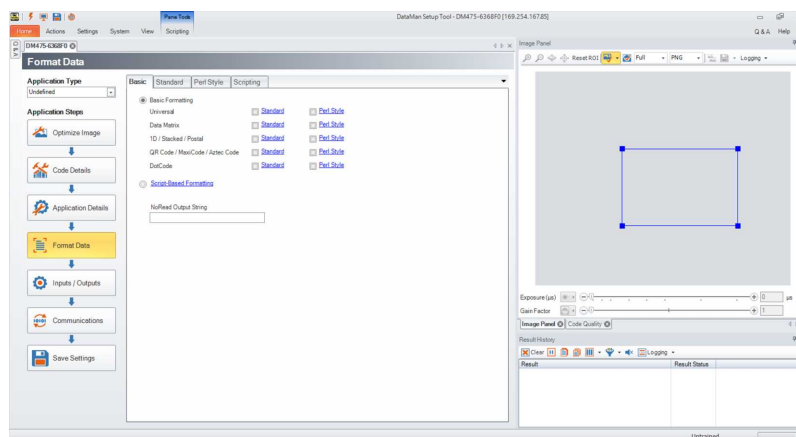

Result Formatting/Scripting

Click **Result Formatting/Scripting** to open the **Scripting** tab in the **Format Data** application step in Setup Tool. Create a script for outputting results or load a pre-written snippet in this window.

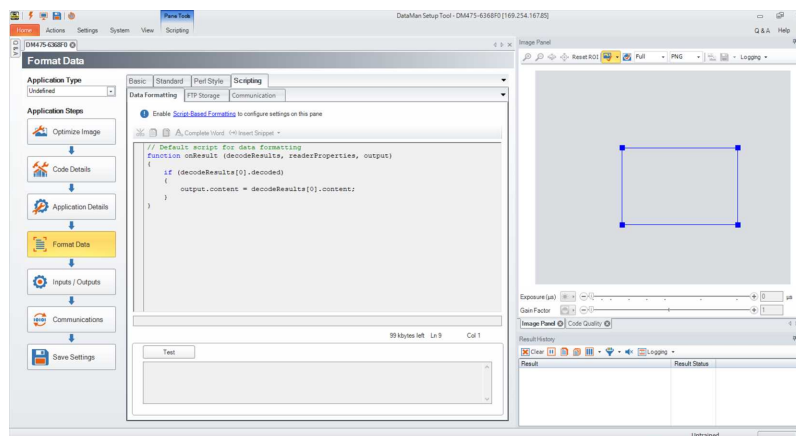

Results through FTP

In the Results Through FTP section, three options are available to navigate to windows in the Setup Tool that connect to an FTP server for exporting verification:

- Image FTP Settings
- Result FTP Settings
- Report (scripting) FTP Settings

For more information, see [Setting Up FTP Transfer on page 40](#).

Image FTP Settings

Click **Image FTP Settings** to open the **Image Transfer** tab in the **Format Data** application step in Setup Tool. Enter information in this window to set up image export via FTP transfer.

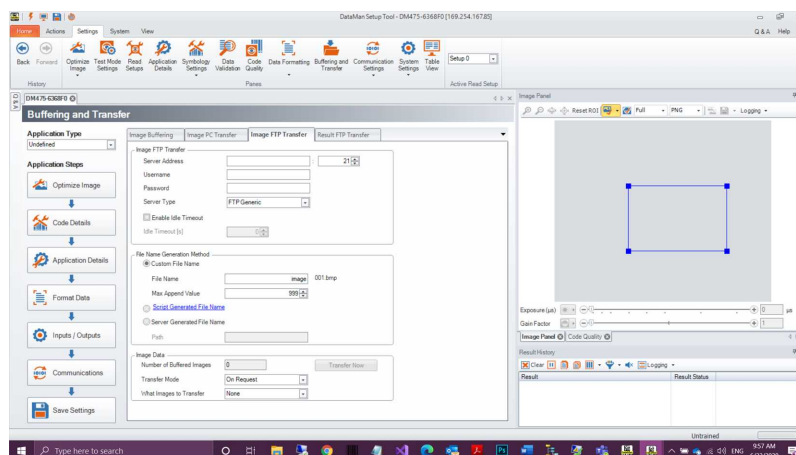

Result FTP Settings

Click **Result FTP Settings** to open the **Result FTP Transfer** tab in the **Format Data** pane in Setup Tool. Enter information in this window to export verification results via FTP transfer.

Note: Minimize TruCheck window and click Setup Tool window on the taskbar.

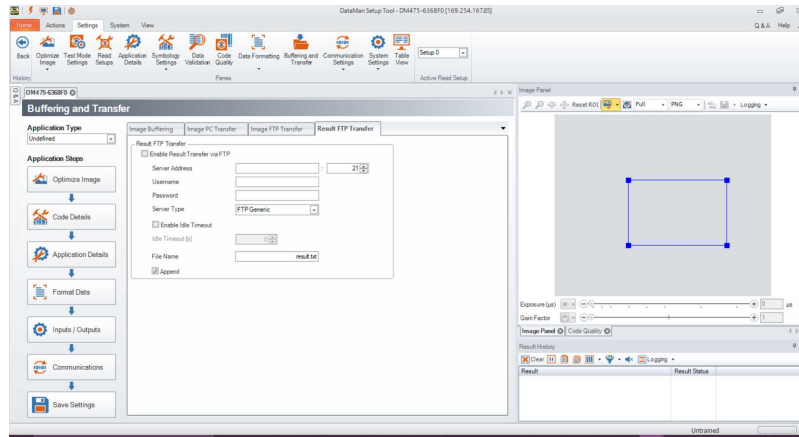

Report (scripting) FTP Settings

Click **Report FTP Settings** to open the **Report FTP Transfer** tab in the **Code Quality** application step in Setup Tool. Enter information in this window to export verification results via FTP Transfer.

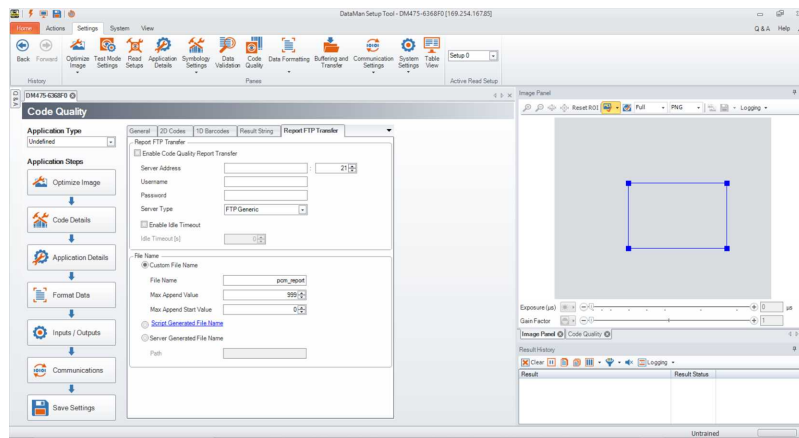

Symbologies/Multi Mode

Navigate to panes and pages in Setup Tool that enable and disable symbology types and set up the verification of multiple symbols. For more information, see [Verifications of Multiple Symbols on page 19](#).

Symbologies/Number of Symbols

Select Symbologies/Number of Symbols to open the **Basic** tab in the **Code Details** application step in Setup Tool. Enable or disable any symbology types and enable multiple verification in this window.

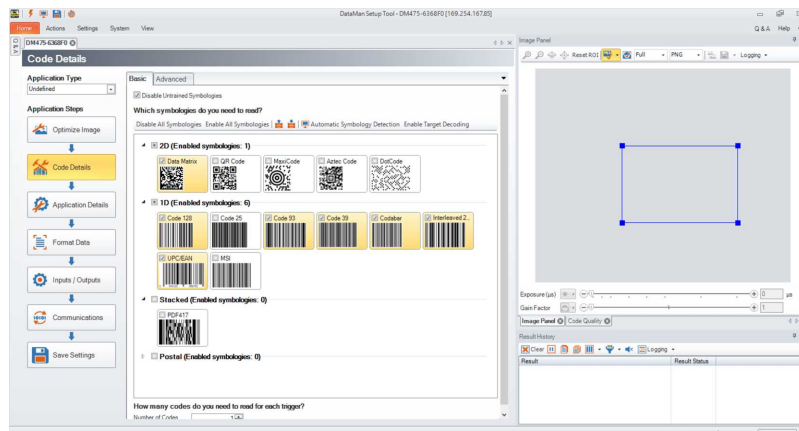

Scripting

Setup Tool allows you to customize a script for outputting results. Use Scripting to output a wide variety of information. For more details on customizing and making your own scripts, see **DataMan Communications and Programming Guide**. For verification results, Setup Tool provides two scripting templates listing the most common output formats for verification results in a csv or an html report.

To enable scripting using the scripting templates provided:

1. Select the **Format Data** application step and the radio button to enable **Script-Based Formatting** on the **Basic** tab.

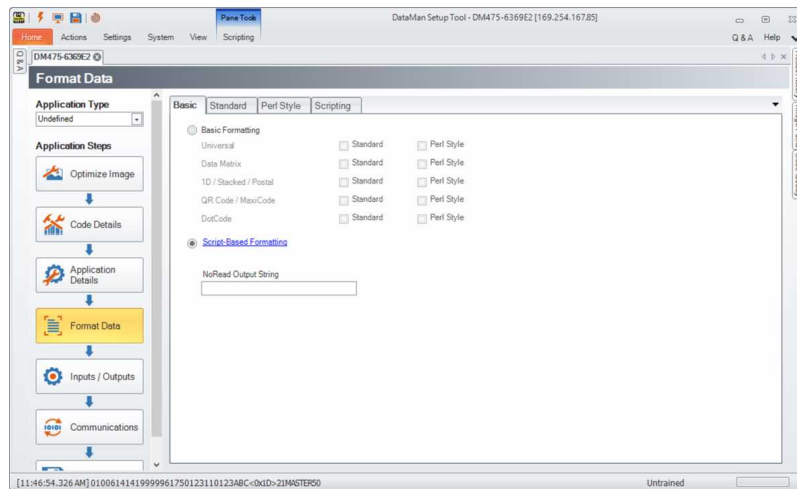

2. Select the **Scripting** tab on the ribbon menu.

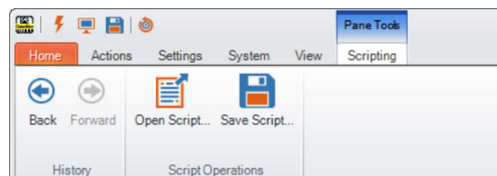

3. In the **Scripting** pane on the ribbon, click **Open Script**.
4. Navigate to the location of the Scripting templates: C:\Program Files (x86)\Cognex\DataMan\DataMan Software vx.x.x\Scripts. One scripting template generates results to a .csv file and the other generates results to an .html file.
5. To save the output to a file, click the **Results History** window on the right.
6. In the **Logging** option, check the box to **Log all result codes to file system** and select the option for **Logging and reporting settings...**

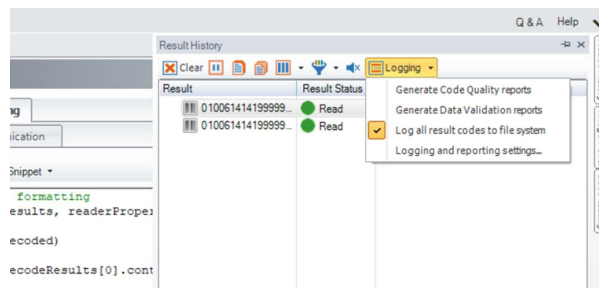

7. In the **Logging and reporting settings** menu, enter a file **Path** and **File Name** under the **Result Code** section.

After providing a **File Name**, you must include either “.csv” or “.html” depending on which template is selected.

8. Select **OK** to save and exit.

Note: If you do not include .csv or .html after the file name, it will not save the report correctly.

Result Code	
Path	C:\
File Name	sample report.html

You can customize the scripts to show more or less detail. For the full list of scripting options, see the **DataMan Communications and Programming Guide**.

Setting Up FTP Transfer

To configure the Dataman 475V to export verification results by FTP, change settings in Setup Tool to communicate with an external FTP server. Setup Tool can export information about:

- The image used for verification
- The result information provided from the **Result History** pane in Setup Tool
- The verification results provided in the **Code Quality** report.

To begin setting up an FTP server, configure an FTP server to communicate with Setup Tool. To set up the necessary information in the Setup Tool window, choose from three panes available for FTP transfer depending on what you would like to transfer:

- Image FTP Transfer
- Result FTP Transfer
- Report (scripting) FTP Transfer

The TruCheck window provides shortcuts to the three Setup Tool panes under **Settings**, in the **Results through FTP** section of the **Navigation** menu. For more information, see [Navigation on page 35](#).

You can also click **Settings** in Setup Tool in the ribbon menu and open **Buffering and Transfer** to access the FTP settings.

Image FTP Transfer

To set up image transfer via FTP, fill in the **Server Address**, the **Username**, and the **Password** (if applicable) fields based on the setup of your FTP server settings.

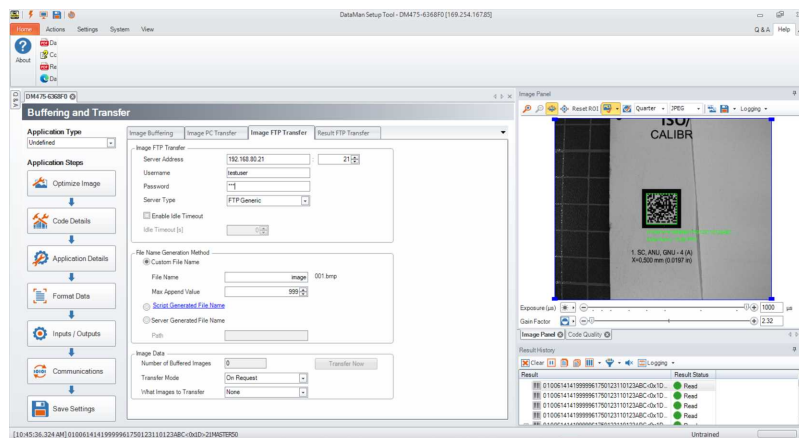

Result FTP Transfer

To set up result transfer via FTP, fill in the **Server Address**, the **Username**, and the **Password** (if applicable) fields based on the setup of your FTP server settings. Selecting this option exports the results available in the **Result History** pane of Setup Tool for exporting to an FTP server. After all required fields are filled in, select the box next to **Enable Result Transfer via FTP**. Use these settings when exporting verification results using scripting. In case of using one of the included CSV script snippets, include the .csv file extension at the end of the **File Name** field, for example *VerificationResults.csv*.

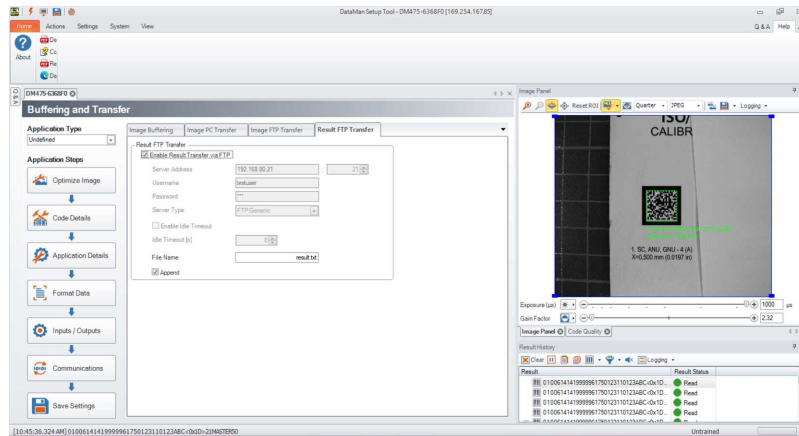

Report FTP Transfer

To set up report transfer via FTP, fill in the **Server Address**, the **Username**, and the **Password** (if applicable) fields based on the setup of your FTP server settings. Selecting this option exports the **Code Quality** report information to an FTP server. After all required fields are filled in, select the box next to **Enable Code Quality Report Transfer**.

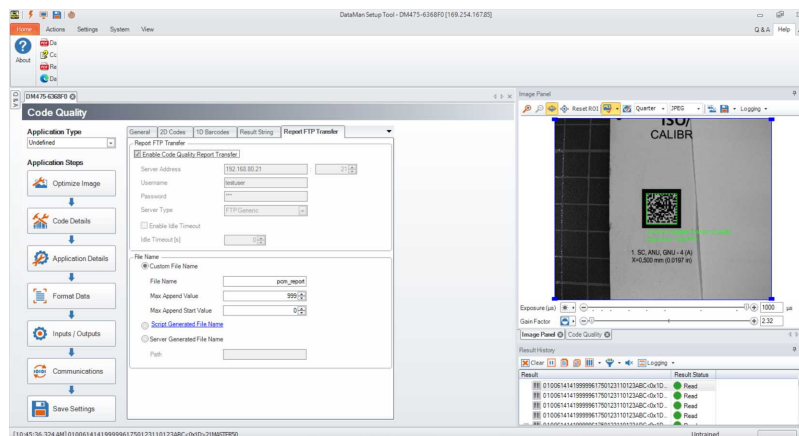

Grading Standards and their Parameters

Depending on the application two global quality grading standards are available for 2D symbols:

- ISO 15415
- ISO 29158 (AIM-DPM)

ISO/IEC 15415 Grading Parameters

The ISO/IEC 15415 standard specifies those measuring, evaluating and grading methods and parameters, which determine the quality of 2D symbols, and identifies possible causes of symbol errors.

- **UEC (Unused Error Correction)** is the percentage of error correction capability that is available for further incorrect modules. The assignment of grade is according to the following table:

UEC %	Grade
$62 \leq x$	A (4.0)
$50 \leq x < 62$	B (3.0)
$37 \leq x < 50$	C (2.0)
$25 \leq x < 37$	D (1.0)
$x < 25$	F (0)

- **SC (Symbol Contrast)** is the difference in reflectivity between the brightest module and the darkest module. The assignment of grade is according to the following table:

SC%	Grade
$70 \leq x$	A (4.0)
$55 \leq x < 70$	B (3.0)
$40 \leq x < 55$	C (2.0)
$20 \leq x < 40$	D (1.0)
$x < 20$	F (0)

- **MOD and RM (Modulation)** is a grade based on the amount of variability in reflectivity of the modules. A multi-step process is used to get the modulation grade. First, the reflectivity of each module is compared to the global threshold and the overall symbol contrast according to the following formula:

$$\text{MOD} = 2 * (\text{abs}(R - \text{GT})) / \text{SC}$$

The Global Threshold GT is the midpoint between the reflectance of the brightest module and the reflectance of the darkest module. Next, the grade level for each module is determined from the MOD value according to the following table:

MOD %	Grade
$50 \leq x$	A (4.0)
$40 \leq x < 50$	B (3.0)
$30 \leq x < 40$	C (2.0)
$20 \leq x < 30$	D (1.0)
$x < 20$	F (0)

The value of the grade for the Modulation parameter is the highest modulation level for which the modules meeting that level result in a notional Unused Error Correction grade of that level or higher. The module with the lowest MOD is

reported as Contrast Uniformity (CU) in General Characteristics to facilitate conformance testing to the requirements of ISO/IEC 15426-2.

The RM parameter works in a similar way, except that for modules which are corrected as errors by the error correction, the MOD% is taken as 0 and counts as F in the final evaluation of the Modulation parameter grade according to the notional Unused Error Correction grade.

- **ANU (Axial Non-uniformity)** is the amount of “out of square” the modules are, that is, a measure of the overall aspect ratio of the symbol. For rectangular symbols which are not square shaped, the ANU parameter reports the deviation from its “correct” aspect ratio.

ANU %	Grade
$x \leq 6$	A (4.0)
$6 < x \leq 8$	B (3.0)
$8 < x \leq 10$	C (2.0)
$10 < x \leq 12$	D (1.0)
$12 < x$	F (0)

- **GNU (Grid Non-uniformity)** is the worst-case distance between the calculated center of a module and the ideal location for the center of the module based on perfectly evenly spaced modules. The calculated center of the module is determined using clock track edges in accordance with the reference decode algorithm. The value is reported as a percentage of a module size.

GNU %	Grade
≤ 38	A (4.0)
$38 < x \leq 50$	B (3.0)
$50 < x \leq 63$	C (2.0)
$63 < x \leq 75$	D (1.0)
$75 < x$	F (0)

- **FPD (Fixed Pattern Damage)** is the overall grade for all the fixed pattern components. This grade is equal to the lowest grade of all the components listed.

The following is a list of components of the finder pattern for Data Matrix symbols. For QR Code symbols, the parameters described in **ISO 18004 QR Code Grading Parameters** are applicable, see [ISO 18004 QR Code Grading Parameters on page 46](#).

- **LLS (Left ‘L’ Side)** is a grade based on imperfections in the left ‘L’ side of the finder pattern. There are two checks required to pass.

First requirement:

- Stretch of 4 correct modules separate gaps
- Gaps are made up of 3 modules or less

- Second requirement:
 - Grade assigned according to the table is not fail.
 - The grade is calculated by the percentage of correct modules
 - **BLS (Bottom 'L' Side)** is a grade based on imperfections in the bottom 'L' side of the finder pattern (see Left 'L' Side).
 - **BQZ (Bottom Quiet Zone)** is a grade based on imperfections in the quiet zone, which is a one-module area below the bottom 'L' side.
 - **LQZ (Left Quiet Zone)** is a grade based on imperfections in the quiet zone, which is a one-module area to the left of the left 'L' side. The grade is based on the percentage of modules, which are correct using the same grading table as for the 'L' sides.

% of incorrect modules	Grade
0	A (4.0)
$0 < x \leq 9$	B (3.0)
$9 < x \leq 13$	C (2.0)
$13 < x \leq 17$	D (1.0)
$17 < x$	F (0)

The grade is the highest modulation level in which the first (gap test) passes and the correct module percentage results in a grade of that level or higher.

- **TQZ (Top Quiet Zone)** is a grade based on imperfections in the quiet zone, which is a one-module area above the Top Clock Track.
 - **ULQZ (Upper Left Quiet Zone)** is the top quiet zone above the upper left quadrant. Used only for 2 and 4 quadrant symbols, this is the grade based on the segment of the quiet zone above the top clock track of the left quadrant.
 - **URQZ (Upper Right Quiet Zone)** is the top quiet zone above the upper right quadrant. Used only for 2 and 4 quadrant symbols, this is the grade based on the segment of the quiet zone above the top clock track of the right quadrant.
- **RQZ (Right Quiet Zone)** is a grade based on imperfections in the quiet zone, which is a one-module area to the right of the Right Clock Track.
 - **RUQZ (Right Quiet Zone to the right of the upper right quadrant)**: Only for 2 and 4 quadrant symbols, this is the grade based on the segment of the quiet zone to the right of the upper right quadrant.
 - **RLQZ (Right Quiet Zone to the right of the lower right quadrant)**: Only for 4 quadrant symbols, this is the grade based on the segment of the quiet zone to the right of the lower left quadrant.
- **TTR (Top Transition Ratio)** is a grade based on imperfections in the Top Clock Track, with relation to its adjoining quiet zone. Since the number of transitions in the quiet zone is zero, the ideal value for this parameter is zero. As the number of teeth in the clock track increases (larger symbols), more transitions in the quiet zone can be tolerated. More transitions in the clock track, which are really imperfections, also improve Top Transition Ratio. The grading scheme for this transition ratio is:

Transition Ratio %	Grade
$x \leq 6$	A (4.0)
$6 < x \leq 8$	B (3.0)

Transition Ratio %	Grade
$8 < x \leq 10$	C (2.0)
$10 < x \leq 12$	D (1.0)
$12 < x$	F (0)

- **ULQTTR (Transition ratio for Upper Left Quadrant Top Clock Track):** Only for 4 quadrant symbols, this is the grade based on the clock track segment at the top of the upper left quadrant. For a 2 quadrant symbol, this is labeled LQTTR.
- **URQTTR (Transition ratio for Upper Right Quadrant Top Clock Track):** Only for 4 quadrant symbols, this is the grade based on the clock track segment at the top of the upper right quadrant. For a 2 quadrant symbol this is labeled RQTTR.
- **LLQTTR (Transition ratio for Lower Left Quadrant Top Clock Track):** Only for 4 quadrant symbols, this is the grade based on the clock track segment at the top of the lower left quadrant.
- **LRQTTR (Transition ratio for Lower Right Quadrant Top Clock Track):** Only for 2 and 4 quadrant symbols, this is the grade based on the clock track segment at the top of the lower right quadrant.

RTR (Right Transition Ratio): Transition ratio for the right clock track in relation to the right quiet zone

- **ULQRTR (Transition ratio for Upper Left Quadrant Right Clock Track):** Only for 2 and 4 quadrant symbols, this is the grade based on the clock track segment to the right of the upper left quadrant. For a 2 quadrant symbol, this is labeled LQRTR
 - **URQRTR (Transition ratio for Upper Right Quadrant Right Clock Track):** Only for 2 and 4 quadrant symbols, this is the grade based on the clock track segment to the right of the upper right quadrant. For 2 quadrant symbols, this is labeled RQRTR.
 - **LLQRTR (Transition ratio for Lower Left Quadrant Right Clock Track):** Only for 4 quadrant symbols, this is the grade based on the clock track segment to the right of the lower left quadrant.
 - **LRQRTR (Transition ratio for Lower Right Quadrant Right Clock Track):** Only for 4 quadrant symbols, this is the grade based on the clock track segment to the right of the lower right quadrant.
- **TCT (Top Clock Track)** is a grade based on imperfections in the top clock track. Some imperfections in the clock track can be tolerated. As a rule maintaining for a passing grade is that three out of every five modules on a consecutively rolling window of five modules must be correct. The value of the grade is the highest modulation level for which this test passes.
 - **ULQTCT (Top Clock Track for Upper Left Quadrant):** Only for 2 and 4 quadrant symbols, this is the grade based on the clock track segment at the top of the upper left quadrant. For 2 quadrant symbols this is labeled LQTCT.
 - **URQTCT (Top Clock Track for Upper Right Quadrant):** Only for 2 and 4 quadrant symbols, this is the grade based on the clock track segment at the top of the upper right quadrant. For 2 quadrant symbols this is labeled RQTCT.
 - **LLQTCT (Top Clock Track for Lower Left Quadrant):** Only for 4 quadrant symbols, this is the grade based on the clock track segment at the top of the lower left quadrant.
 - **LRQTCT (Top Clock Track for Lower Right Quadrant):** Only for 4 quadrant symbols, this is the grade based on the clock track segment at the top of the lower right quadrant.

- **RCT (Right Clock Track)** is a grade based on imperfection in the right clock track. Some imperfections in the clock track can be tolerated. As a rule maintaining for a passing grade is that three out of every five modules on a consecutively rolling window of five modules must be correct. The value of the grade is the highest modulation level for which this test passes..
 - **ULQRCT (Right Clock Track for Upper Left Quadrant)**: Only for 2 and 4 quadrant symbols, this is the grade based on the clock track segment to the right of the upper left quadrant. For 2 quadrant symbols, this is labeled LQRCT.
 - **URQRCT (Right Clock Track for Upper Right Quadrant)**: Only for 2 and 4 quadrant symbols, this is the grade based on the clock track segment to the right of the upper right quadrant. For 2 quadrant symbols, this is labeled RQRCT.
 - **LLQRCT (Right Clock Track for Lower Left Quadrant)**: Only for 4 quadrant symbols, this is the grade based on the clock track segment to the right of the lower left quadrant.
 - **LRQRCT (Right Clock Track for Lower Right Quadrant)**: Only for 4 quadrant symbols, this is the grade based on the clock track segment to the right of the lower right quadrant.
- **AG (Average Grade of Damage across many parts of the Finder Pattern)** is a grade that considers the accumulated effect of damage to several parts of the finder pattern. Five values are averaged together. One of these is the lowest of all the grades associated with all the clock track segments, namely TCT, TTR, TQZ and RCT, RTR, RQZ. The other four are LLS, BLS, LQZ, and BQZ. The average falls in the range of 0 through 4.0 and is given a grade according to the following:

Ave Grade	Grade
Equals 4.0	A (4.0)
$3.5 \leq x < 4.0$	B (3.0)
$3.0 \leq x < 3.5$	C (2.0)
$2.5 \leq x < 3$	D (1.0)
$x < 2.5$	F (0)

Note: The effect of the AG parameter is to lower the overall grade of symbols, which have several individual parameters at or near the same level. For example, with enough B grades in individual parameters, the overall grade may come out as a C grade rather than a B.

- **DECODE:** Reports whether the 2D Symbol is decoded in accordance with the reference decode algorithm with the specified aperture.

Note: It is possible to report decoded results, but for a failure to occur when decoding in accordance with the reference decode algorithm. In this case, the DECODE grade is F (0).

- **Contrast Uniformity (CU)** is the value of MOD (modulation) for the worst case module selected from a 2D Matrix symbol. This is useful for process control, as way of measuring the drift in reflectivity consistency, and for testing conformance to ISO/IEC 15426-2, which requires the modulation of a specific module within a conformance test symbol to be reported. This parameter is reported in General Characteristics.

ISO 18004 QR Code Grading Parameters

- **ULP (Upper Left Pattern), URP (Upper Right Pattern) and LLP (Lower Left Pattern):** three identical components of the finder pattern found in the respective corners of the QR Code symbol. Each finder pattern is composed of 7x7 dark modules, 5x5 light modules, and 3x3 dark modules. MicroQR code contains one finder pattern in the upper, left corner of the symbol.

- **HCT** (Horizontal Clock Track): The horizontal timing pattern consisting of a one module row of alternating dark and light modules.
- **VCT** (Vertical Clock Track): The vertical timing pattern consisting of a one module row of alternating dark and light modules.
- **ALP** (Alignment Pattern): The alignment pattern consists of 5x5 dark modules, 3x3 light modules, and a single central dark module. The alignment pattern is only present in QR Codes version 2 or higher.
- **FIB** (Format Information Block): The format information block is the encoded pattern containing information on symbol characteristics such as the Error Correction Level and the data mask pattern.
- **VIB** (Version Information Block): The version information block is the encoded pattern containing information on the symbol version. The version information block is only present on QR Codes version 7 or higher.

ISO 29158 (AIM-DPM) 2006 Grading Parameters

The ISO 29158 (AIM-DPM) method of grading Data Matrix symbols modifies the process of ISO-15415 and is appropriate for direct part marking (DPM) applications. In ISO 29158 (AIM-DPM) method, the image brightness is adjusted to produce an image of the symbol that fills most or all of the dynamic range of the imager, resulting in an image that is easy to see. The threshold between dark and light is calculated from the statistics of the image brightness histogram. Therefore, the measurements calculated by AIM-DPM differ from those of ISO 15415 significantly. Some of the parameters reported in ISO 15415 are changed completely and are renamed to avoid confusion between the two methods:

AIM-DPM Parameter Name	ISO 15415 Parameter Name	Summary of Change(s)
CC (Cell Contrast)	SC (Symbol Contrast) For more information, see ISO/IEC 15415 Grading Parameters on page 42	Made relative to light background.
CM (Cell Modulation)	MOD (Modulation) For more information, see ISO/IEC 15415 Grading Parameters on page 42	Threshold calculated from statistics rather than the maximum and minimum reflectance. Grading scale range set to Mean of distribution, rather than maximum and minimum reflectance.
DD (Distributed Damage)	AG (Average Grade) For more information, see ISO/IEC 15415 Grading Parameters on page 42	Modulation overlay uses only A, B, D, and F levels, leaving out C level.
MR (Minimum Reflectance)	N/A	An absolute limit on SC of 5% added to temper the relative nature of CC and "catch" extremely low contrast symbols.

Fixed Pattern Damage grading parameters have the same names except for AG, but are functionally different. The global threshold and modulation grading scale are different. As symbols obtain a significantly higher grade according to AIM-DPM than ISO 15415, AIM-DPM grading is appropriate only when called for in an application specification.

AIM-DPM varies the size of the aperture until the symbol is decoded, then the grading is repeated with 50% and 80% aperture sizes. The higher result is reported as the final grade.

Note: When the reference decode algorithm fails to decode a symbol with both 50% and 80% aperture, the **DECODE** grade is "F" and a note is printed on the grade section of the report, even if the symbol is recognized and decoded with a different aperture size in an earlier phase of the grading procedure.

The following parameters are new or modified for AIM-DPM:

- **CC (Cell Contrast):** Similar to SC, the relative contrast value between bars and spaces, taken from the means of the light and dark element $CC = (Lmean - Dmean) / Lmean$.

CC%	Grade
≥ 30%	4
≥ 25%	3
≥ 20%	2
≥ 15%	1
< 15%	0

- **CMOD (Cell Modulation):** Similar to MOD in ISO 15415, CMOD measures the deviation in the reflectivity of dark and light elements. A range for each light and dark group is created from the global threshold to the mean reflectance of the elements. Each module is graded along the created range, then error correction capability is considered to “discount” the effect of one or a few elements with low values, and a final grade is computed for this parameter.
- **DDG (Distributed Damage Grade):** Similar to AG in ISO 15415, DDG considers the effect of multiple segments of the fixed pattern having imperfections. Where multiple segments have a low grade, the effect of “distributed damage” is reflected in a lower grade for DDG than the lowest of the individual segments.
- **MR (Minimum Reflectance):** This is a requirement for at least 5% reflectance difference between light and dark elements as a restraint on the purely relative CC parameter.
- **Decode:** Decode grade A or F depending upon whether the reference decode algorithm succeeds in decoding the symbol with the required final aperture size.

Traditional (Non-Graded) Parameters

PCS

A way of Quantifying Contrast is Print Contrast Signal (PCS), an older and rarely used measure of contrast. Contrast is intended to quantify the difference between the bars and the spaces in reflectance. PCS is defined mathematically as:

$$PCS = (R_{max} - R_{min}) / R_{max}$$

The equation is equivalent to the percentage of the light background accounted for by the difference between the bars and spaces. PCS was defined as a measure of contrast the human eye perceives before and outside the context of measuring barcode contrast. The measurement is made relative to the brightness of the background. The darker (worse) the background color is, the higher (supposedly better) the value of PCS. Scanners are sensitive to the absolute difference between the reflectance of bars and spaces. Readers are especially sensitive to variations in contrast within the same scan.

MRD

Minimum Reflectance Difference (MRD) quantifies the minimum difference anywhere across the barcode. These worst-case bar and space are not necessary adjacent to one another.

ISO/IEC 15416 (ANSI x3.182) Grading Parameters

The ANSI parameters section lists each of the nine ANSI parameters, explain what is measured during successful or unsuccessful barcode reading, and summarizes the measurements based on all scans. For a review of the ANSI process given on each of your codes, check the ANSI Matrix for each code described below.

Note: Some of these parameters are average values over all of the scans, and the averages can skew or alter the apparent results.

When a code is not read, the scan is analyzed for apparent quiet zones and the bars and spaces in between are used for the ANSI analysis.

1. **EDGE: Edge Determination**

Checks if the edge between bar and space can be detected and no false bars or spaces appear due to “splitting” of bars or ink splattered in spaces. If at least one scan results in a decoded barcode, the EDGE value is the number of bars and spaces in the code, not including quiet zones. If no scans result in a decoded barcode, the EDGE value shown is the number of bars and spaces found between quiet zones or apparent quiet zones on the scan on which the most bars and spaces were found. The Scan Reflectance Profile graph can also help in analyzing a code that cannot be decoded.

2. **RI/RD: Minimum Reflectance**

Checks if the darkness of the bars is sufficient. The amount of light reflected by the bars (bar reflectance) must be less than half the light reflected by the spaces (space reflectance). The values shown are the light reflectance and the dark element reflectance separated by a slash. The light reflectance is the maximum reflectivity found in the scan (lightest or best space), and the dark reflectivity is the minimum reflectivity found in the scan (darkest or best bar). The requirement is for the minimum reflectivity to be no more than half the maximum reflectivity. If this requirement is met, the grade is A, otherwise it is F.

3. **SC: Symbol Contrast**

Measures the contrast between the brightest space and darkest bar. The result is assigned a letter grade of A, B, C, D, or F, with A being the highest contrast. The contrast is the difference between the maximum reflectivity (lightest or best space) and the minimum reflectivity (darkest or best bar). Note that Symbol Contrast is the difference between light and dark, and RI/Rd above checks the ratio of these values.

SC %	Grade
$x \geq 70$	A (4.0)
$70 > x \geq 55$	B (3.0)
$55 > x \geq 40$	C (2.0)
$40 > x \geq 20$	D (1.0)
$20 > x$	F (0)

4. **MinEC: Minimum Edge Contrast**

Checks if the contrast between adjacent bars and spaces is high enough. If the difference between the light and dark elements is not significant, barcode readers fail to locate edges between bars and spaces.

Note: MinEC finds the worst-case contrast difference between each bar to space transition, whereas symbol contrast finds the best-case difference at any point across the barcode.

5. MOD: Modulation

Modulation checks the edge contrast as a fraction of the overall or best case contrast measured in symbol contrast. Modulation is a measure of minimum edge contrast since most barcode readers employ adaptive thresholding circuits to detect transitions between bars and spaces. If all bars and spaces were the same brightness, the minimum edge contrast would be equivalent to the symbol contrast, resulting in 100% modulation. If some spaces are less bright than the brightest one, modulation is some fraction of the overall contrast. Modulation therefore measures the amount of available contrast that is manifested in the worst-case bar to space transition. The percentage is assigned a letter grade.

Excessive ink spread or bar growth can result in low modulation because very narrow spaces appear to be filled in by the encroaching bars in the Scan Reflectance Profile.

MOD %	Grade
$x \geq 70$	A (4.0)
$70 > x \geq 60$	B (3.0)
$60 > x \geq 50$	C (2.0)
$50 > x \geq 40$	D (1.0)
$40 > x$	F (0)

6. Def: Defects

The worst-case change in reflectance within a single bar or space is a defect. The largest difference in reflectivity found in a single bar or space is measured as a percentage of the symbol contrast and assigned a letter grade. Defects measure breakups or voids within bars, ink spots in spaces, or even the grain of a substrate in spaces.

Def %	Grade
$x \leq 15$	A (4.0)
$15 < x \leq 20$	B (3.0)
$20 < x \leq 25$	C (2.0)
$25 < x \leq 30$	D (1.0)
$30 < x$	F (0)

7. DCD: Decode

The widths of each bar and space are measured and used to interpret the data content of the barcode according to a specific mathematical formula appropriate for the barcode type. If the barcode cannot be decoded according to the formula, the accuracy of the bar and space widths are inadequate. The printout shows the number of scans decoded over the number of scans taken, for example 8/10 means 8 out of 10 scans decoded.

8. DEC: Decodability

Determines how accurate the bar and space widths are and how easily the widths can be determined. A perfectly accurate barcode has 100 percent decodability, but decodability as low as 25 percent is often acceptable. Decodability is the percentage of the overall tolerance range for a bar or space width that is not used up by inaccuracies.

DEC %	Grade
$x \geq 62$	A (4.0)
$62 > x \geq 50$	B (3.0)
$50 > x \geq 37$	C (2.0)
$37 > x \geq 25$	D (1.0)
$25 > x$	F (0)

9. QZ: Quiet Zone

Quiet Zone refers to a dedicated amount of blank space on the left and right of the barcode. Each symbology specifies a minimum quiet zone.

Setting Up DataMan Setup Tool

This section provides information on the installation process of the DataMan Setup Tool and external triggers.

Reading your first Code

Follow the steps below to install and connect your verifier to the DataMan Setup Tool:

1. Check the DataMan **Release Notes** for a full list of system requirements found at C:\Program Files (x86)\Cognex\DataMan\DataMan Software v6.1.9\Documentation\English.
2. Download the latest version of the DataMan Setup Tool from <http://www.cognex.com/support/dataman> and follow the on-screen steps.
3. Connect the DataMan 475 verifier to your PC using the x-coded Ethernet cable and power the reader using the breakout cable.
4. Launch the DataMan Setup Tool and click **Refresh**.

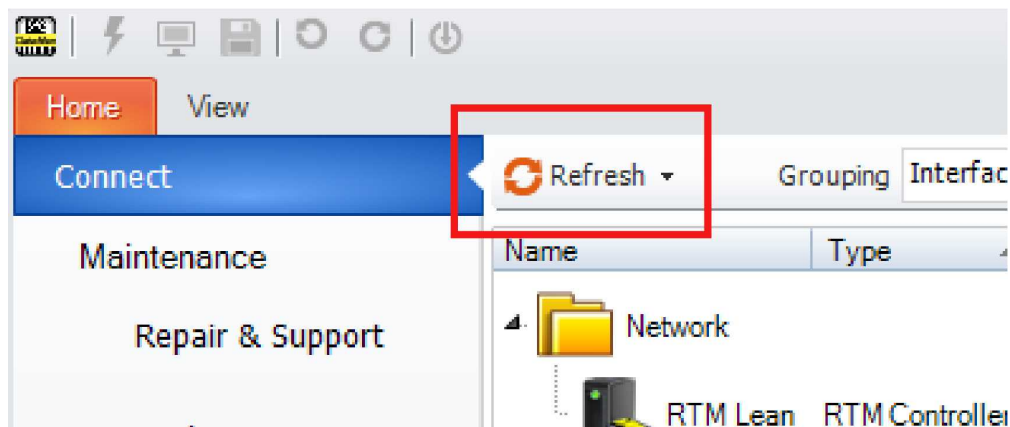

Note: Detected readers appear under **COM ports** or **Network devices**, or both.

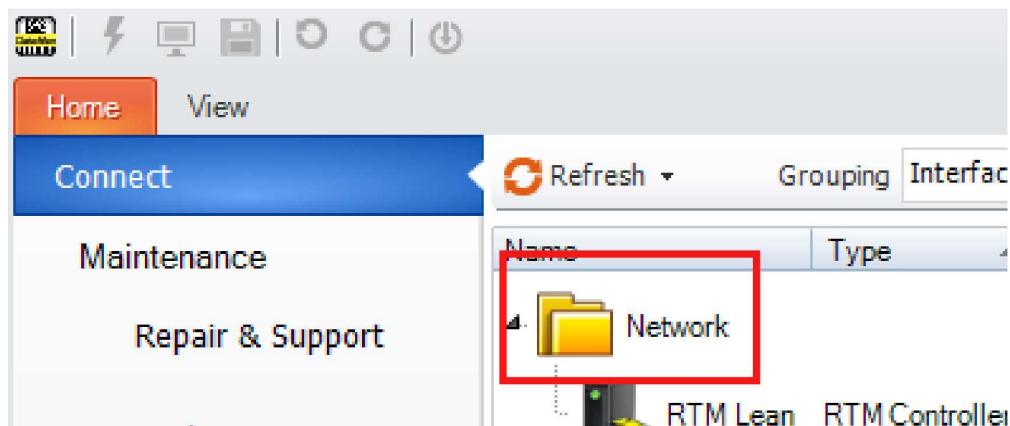

If the verifier does not appear, you can use either the **Add Device** or **Force Network Settings** options in the DataMan Setup Tool under **Repair & Support**. For more information, see the DataMan *Setup Tool Reference Manual*.

5. Select a verifier from the list and double click it or click **Connect**.

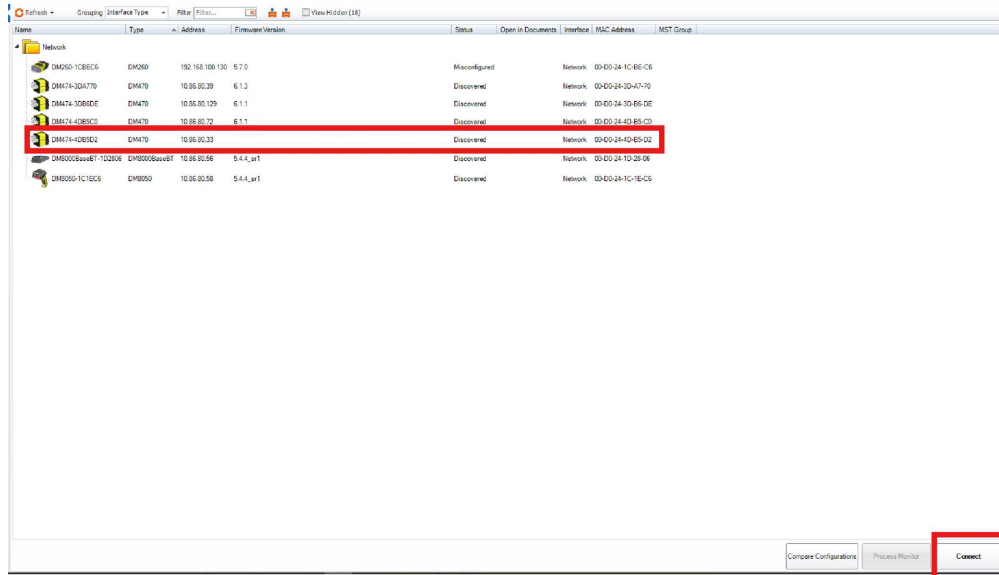

6. After connecting, the TruCheck window automatically opens.

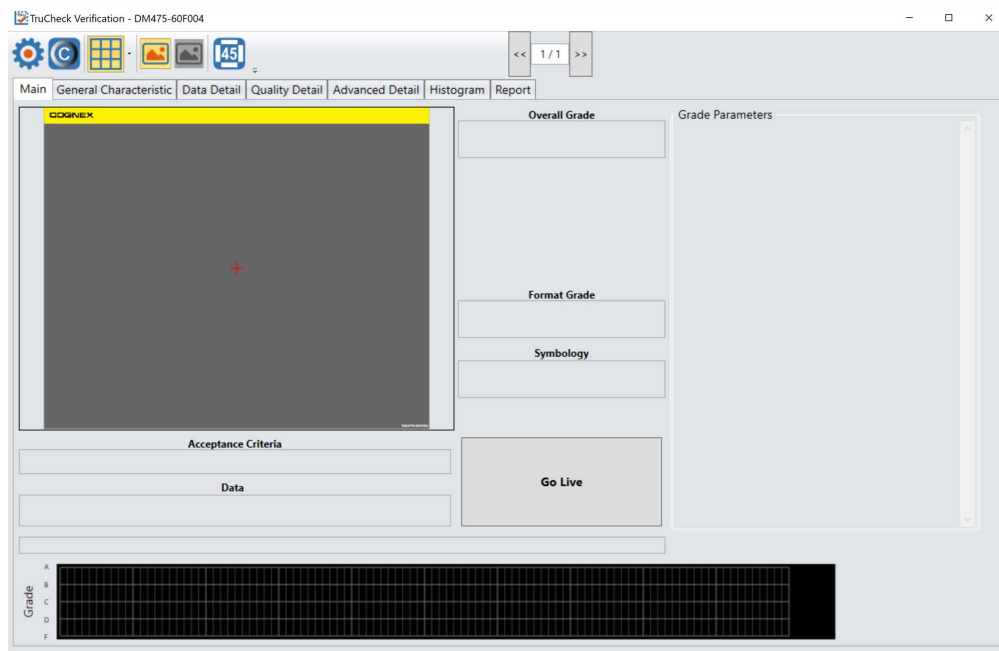

Note: If TruCheck does not open or needs to be re-opened at any point during verification, select the TruCheck window icon under the **View** tab in Setup Tool.

Note: If you are running the DM475V at line speed, you may need to disconnect Setup Tool and obtain results through the device output interface.

WARNING: Do not stare into the beam when adding, removing, or changing cables. Cognex recommends to disconnect the reader from power whenever you make physical changes to it.

Follow the steps below to connect your reader to power and network:

CAUTION: I/O wiring or adjustments to I/O devices should be performed when the verifier is not receiving power.

CAUTION: The Ethernet cable shield must be grounded at the far end. Whatever this cable is plugged into (usually a switch or router) should have a grounded Ethernet connector. A digital voltmeter should be used to validate the grounding. If the far end device is not grounded, a ground wire should be added in compliance with local electrical codes.

1. Connect the I/O+RS232+24V cable to your reader.
2. Connect your reader through an Ethernet cable to your network for a network connection.
3. Connect the cable to a 24V power supply.

External Triggers

If you are using external triggering, you can use any of the following methods to trigger your DataMan 475 verifier:

- Press the trigger button on the reader.
- Send a pulse on the I/O cable:
 - Trigger + (orange or red)
 - Trigger - (black)
- Send a serial trigger command over the RS-232 connection connection.
- Press <CTRL-T> on the keyboard while the DataMan Setup Tool has the input focus.
- Click the **Trigger** button in the DataMan Setup Tool:

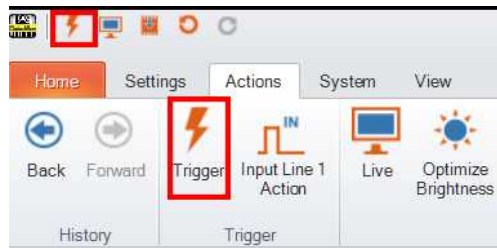

Cleaning and Maintenance

Cleaning the Verifier Housing

To clean the outside of the verifier housing, use a small amount of mild detergent cleaner or isopropyl alcohol on a cleaning cloth. Do not pour the cleaner directly onto the verifier housing.

 **CAUTION:** Do not attempt to clean any DataMan product with harsh or corrosive solvents, including lye, methyl ethyl ketone (MEK) or gasoline.

Cleaning the Verifier Lens Cover

To remove dust from the lens cover, use a pressurized air duster. The air must be free of oil, moisture or other contaminants that could remain on the lens cover. To clean the plastic window of the lens cover, use a small amount of isopropyl alcohol on a cleaning cloth. Do not scratch the plastic window. Do not pour the alcohol directly on the plastic window.

Compliance Information, Warnings and Notices

Precautions

To reduce the risk of injury or equipment damage, observe the following precautions when you install the Cognex product:

- The verifier is intended to be supplied by a UL or NRTL listed power supply with a 24VDC output rated for at least 2A continuous and a maximum short circuit current rating of less than 8A and a maximum power rating of less than 100VA and marked Class 2 or Limited Power Source (LPS). Any other voltage creates a risk of fire or shock and can damage the components. Applicable national and local wiring standards and rules must be followed.
- Route cables and wires away from high-current wiring or high-voltage power sources to reduce the risk of damage or malfunction from the following causes: over-voltage, line noise, electrostatic discharge (ESD), power surges, or other irregularities in the power supply.
- Do not install Cognex products where they are exposed to environmental hazards such as excessive heat, dust, moisture, humidity, impact, vibration, corrosive substances, flammable substances, or static electricity.
- Do not expose the image sensor to laser light. Image sensors can be damaged by direct, or reflected, laser light. If your application requires laser light that might strike the image sensor, use a lens filter at the corresponding laser wavelength. For suggestions, contact your local integrator or application engineer.
- Changes or modifications not expressly approved by the party responsible for regulatory compliance could void the user's authority to operate the equipment.
- Include service loops with cable connections.
- Ensure that the cable bend radius begins at least six inches from the connector. Cable shielding can be degraded or cables can be damaged or wear out faster if a service loop or bend radius is tighter than 10X the cable diameter.
- This device should be used in accordance with the instructions in this manual.
- All specifications are for reference purposes only and can change without notice.

Regulations/Conformity

Note: For the most current CE declaration and regulatory conformity information, see the Cognex support site: cognex.com/support.

DataMan 475 verifiers have Regulatory Model R00062, Label Light (DMV-475V-LBL-0200) has Accessory Model 50162, and meet or exceed the requirements of all applicable standards organizations for safe operation. However, as with any electrical equipment, the best way to ensure safe operation is to operate them according to the agency guidelines that follow. Please read these guidelines carefully before using your device.

Safety and Regulatory	
Manufacturer	Cognex Corporation One Vision Drive Natick, MA 01760 USA
USA	TÜV SÜD SCC/NRTL OSHA Scheme for UL/CAN 61010-1. FCC Part 15, Class A This equipment has been tested and found to comply with the limits for a Class A digital device, pursuant to part 15 of the FCC Rules. These limits are designed to provide reasonable protection against harmful interference when the equipment is operated in a commercial environment. This equipment generates, uses, and can radiate radio frequency energy and, if not installed and used in accordance with the instruction manual, may cause harmful interference to radio communications. Operation of this equipment in a residential area is likely to cause harmful interference in which case the user will be required to correct the interference at his own expense.
Canada	TÜV SÜD SCC/NRTL OSHA Scheme for UL/CAN 61010-1. ICES-003, Class A This Class A digital apparatus complies with Canadian ICES-003. Cet appareil numérique de la classe A est conforme à la norme NMB-003 du Canada.
Europe	DM475 (Regulatory Model R00062) Label Light (DMV-475V-LBL-0200) (Accessory Model 50162) The CE mark on the product indicates that the system has been tested to and conforms to the provisions noted within the 2014/30/EU Electromagnetic Compatibility Directive and the 2011/65/EU RoHS Directive. For further information, please contact: Cognex Corporation, One Vision Drive, Natick, MA 01760, USA. Cognex Corporation shall not be liable for use of our product with equipment (i.e., power supplies, personal computers, etc.) that is not CE.
Korea	A급 기기(업무용 방송통신기자재): 이 기기는 업무용(A급) 전자파적합기기로서 판매자 또는 사용자는 이 점을 주의하시기 바라며, 가정외의 지역에서 사용하는 것을 목적으로 합니다. DM475 (Regulatory Model R00062) Label Light (DMV-475V-LBL-0200) (Accessory Model 50162)
International Product Safety	Conforms to IEC 61010-1, CAN/CSA-C22.2 No. 61010-1:2012 + UPD No. 1:2015-07, UL 61010-1:2012 + R:2015-07, UL 61010-1:2012 + R:2015-07, EN 61010-1:2010.
CB	TÜV SÜD IEC/EN 61010-1. CB report available upon request.

For European Community Users

Cognex complies with Directive 2012/19/EU OF THE EUROPEAN PARLIAMENT AND OF THE COUNCIL of 4 July 2012 on waste electrical and electronic equipment (WEEE).

This product has required the extraction and use of natural resources for its production. It may contain hazardous substances that could impact health and the environment, if not properly disposed.

In order to avoid the dissemination of those substances in our environment and to diminish the pressure on the natural resources, we encourage you to use the appropriate take-back systems for product disposal. Those systems will reuse or recycle most of the materials of the product you are disposing in a sound way.



The crossed out wheeled bin symbol informs you that the product should not be disposed of along with municipal waste and invites you to use the appropriate separate take-back systems for product disposal.

If you need more information on the collection, reuse, and recycling systems, please contact your local or regional waste administration.

You may also contact your supplier for more information on the environmental performance of this product.

