

# DMA-EZCCM-001 User Guide



2020 April 09  
Revision: 5.7.0700002.3



# Legal Notices

The software described in this document is furnished under license, and may be used or copied only in accordance with the terms of such license and with the inclusion of the copyright notice shown on this page. Neither the software, this document, nor any copies thereof may be provided to, or otherwise made available to, anyone other than the licensee. Title to, and ownership of, this software remains with Cognex Corporation or its licensor. Cognex Corporation assumes no responsibility for the use or reliability of its software on equipment that is not supplied by Cognex Corporation. Cognex Corporation makes no warranties, either express or implied, regarding the described software, its merchantability, non-infringement or its fitness for any particular purpose.

The information in this document is subject to change without notice and should not be construed as a commitment by Cognex Corporation. Cognex Corporation is not responsible for any errors that may be present in either this document or the associated software.

Companies, names, and data used in examples herein are fictitious unless otherwise noted. No part of this document may be reproduced or transmitted in any form or by any means, electronic or mechanical, for any purpose, nor transferred to any other media or language without the written permission of Cognex Corporation.

Copyright © 2019. Cognex Corporation. All Rights Reserved.

Portions of the hardware and software provided by Cognex may be covered by one or more U.S. and foreign patents, as well as pending U.S. and foreign patents listed on the Cognex web site at: [cognex.com/patents](http://cognex.com/patents).

---

The following are registered trademarks of Cognex Corporation:

Cognex, 2DMAX, Advantage, AlignPlus, Assemblyplus, Check it with Checker, Checker, Cognex Vision for Industry, Cognex VSOC, CVL, DataMan, DisplayInspect, DVT, EasyBuilder, Hotbars, IDMax, In-Sight, Laser Killer, MVS-8000, OmniView, PatFind, PatFlex, PatInspect, PatMax, PatQuick, SensorView, SmartView, SmartAdvisor, SmartLearn, UltraLight, Vision Solutions, VisionPro, VisionView

The following are trademarks of Cognex Corporation:

The Cognex logo, 1DMax, 3D-Locate, 3DMax, BGAll, CheckPoint, Cognex VSoC, CVC-1000, FFD, iLearn, In-Sight (design insignia with cross-hairs), In-Sight 2000, InspectEdge, Inspection Designer, MVS, NotchMax, OCRMax, PatMax RedLine, ProofRead, SmartSync, ProfilePlus, SmartDisplay, SmartSystem, SMD4, VisiFlex, Xpand

Portions copyright © Microsoft Corporation. All rights reserved.

Portions copyright © MadCap Software, Inc. All rights reserved.

Other product and company trademarks identified herein are the trademarks of their respective owners.

# Table of Contents

<b>Legal Notices</b> .....	<b>3</b>
<b>Table of Contents</b> .....	<b>4</b>
<b>Symbols</b> .....	<b>6</b>
<b>About DMA-EZCCM-001</b> .....	<b>7</b>
Product Description .....	7
Functional Principle .....	7
Supported DataMan Readers .....	7
Multiprotocol Functionality .....	7
Indicator LEDs .....	8
Module LED Status .....	8
I/O LEDs .....	8
Dimensions .....	10
Accessories .....	10
Mounting .....	11
Grounding .....	14
Connecting .....	16
Supply Concept .....	16
Connecting the modules to Ethernet .....	16
Connecting Power Supply .....	17
Connecting Digital Sensors .....	18
Connecting DataMan Readers .....	19
<b>Getting Started</b> .....	<b>21</b>
Setting IP Address .....	21
Setup Tool Connection .....	21
Web GUI .....	22
Memory Mapping .....	24
Setup Device .....	27
Triggering Readers .....	28
Reading Results .....	28
Soft Events .....	29
Advanced Features .....	30
<b>Connecting</b> .....	<b>31</b>
Connecting the device to a Siemens PLC in PROFINET IO .....	31
Used Hardware .....	31
Used Software .....	31
Prerequisites .....	31
Installing the GSDML-file .....	31
Slots and Modules .....	33
Connecting the device to an EtherNet/IP™ PLC .....	35
Commissioning the Device in EtherNet/IP™: .....	35
<b>Troubleshooting</b> .....	<b>40</b>
<b>Maintenance</b> .....	<b>41</b>
Firmware Update .....	41
Repair .....	41

Disposal .....	41
<b>Appendix .....</b>	<b>42</b>
<b>DMA-EZCCM-001 Specifications .....</b>	<b>46</b>
<b>Precautions .....</b>	<b>48</b>
<b>Regulations/Conformity .....</b>	<b>49</b>
Product Identification .....	49
Scope of Delivery .....	49
Legal Requirements .....	49
Safety .....	49
Intended Use .....	49
General Safety Instructions .....	49

# Symbols

The following symbols indicate safety precautions and supplemental information:

---

 **WARNING:** This symbol indicates a hazard that could cause death, serious personal injury or electrical shock.

---

---

 **CAUTION:** This symbol indicates a hazard that could result in property damage.

---

---

 **Note:** This symbol indicates additional information about a subject.

---

---

 **Tip:** This symbol indicates suggestions and shortcuts that might not otherwise be apparent.

---

# About DMA-EZCCM-001

## Product Description

The DMA-EZCCM-001 is a communication module for DataMan readers, which supports daisy chaining over Industrial Ethernet. This device is developed in cooperation with the company Turck.

DMA-EZCCM-001 provides the following features:

- Data Exchange via Multiprotocol functionality Ethernet/IP™ Device or PROFINET IO Device
- 2x M8, 4-pole, Ethernet connection
- Integrated Ethernet switch, which allows line topology
- Transmission speed 10 Mbps/100 Mbps
- 4-pole M8-connectors for voltage supply
- Separated power groups for safety shutdown
- Two interfaces for DataMan connection
- Two universal ports for PNP inputs, which can be configured for trigger
- Integrated web server
- LED displays and diagnostics
- Fibre-glass reinforced housing
- Shock and vibration tested
- Fully potted module electronics
- Degree of protection IP65/IP67/IP69K

## Functional Principle

The devices provide a multiprotocol Ethernet interface for EtherNet/IP™ and PROFINET. The device is connected to Ethernet as PROFINET IO Device or EtherNet/IP™ Device via the Ethernet interface. Process data between Ethernet and DMA-EZCCM-001 are exchanged during runtime. The DataMan interfaces are used for connecting devices Cognex DataMan Barcode Readers.

## Supported DataMan Readers

The following DataMan Series readers can be connected to the device:

- DataMan 70 Series readers
- DataMan 150 Series readers
- DataMan 260 Series readers
- DataMan 360 Series readers
- DataMan 470 Series readers

## Multiprotocol Functionality

The compact communication modules of the EZCCM product line combine two Ethernet-protocols:

- PROFINET
- EtherNet/IP™

A multi-protocol device can be operated without intervention from the user (which means, without changes in the parameterization) in both Ethernet protocols mentioned.

During start-up, after a power-on, the module runs in "snooping" mode and detects the Ethernet protocol which requests a link connection by listening to the traffic. If a protocol is detected, the device is set automatically to the respective protocol. After this an access to the device from other protocols is read-only.

## Indicator LEDs

### Module LED Status

LED	Color	Status	Description
ETH1/ETH2	Green	ON	Ethernet link (100 Mbps)
		Flashing	Ethernet communication (100 Mbps)
	Yellow	ON	Ethernet link (10 Mbps)
		Flashing	Ethernet communication (10 Mbps)
	-	OFF	No Ethernet link
BUS	Green	ON	Active connection to Primary reader
		Flashing	Steady flashing: Ready Sequence of 3 flashes in 2 seconds: operating active
	Red	ON	IP address conflict or Restore Mode or Modbus timeout
		Flashing	Blink/Wink command active
	Red/Green	Alternating	Waiting for assignment of an IP address, DHCP or BootP
-	OFF	Power off	
ERR	Green	ON	Diagnostics disabled
	Red	ON	Diagnostics enabled V <sub>2</sub> undervoltage diagnosis is parameter-dependent
PWR	Green	ON	V <sub>1</sub> and V <sub>2</sub> power on
	Red	ON	V <sub>2</sub> power off or below the defined tolerance of 18V
	-	OFF	V <sub>1</sub> power off or below the defined tolerance of 18V

### I/O LEDs

LED	Color	Status	Description
LED TX	GREEN	Flashing	Data is being transmitted.
LED RX	GREEN	Flashing	Data is being received.
	RED	Flashing	Data is being received, protocol error. (Parity, Baud rate, ASCII/RTU)
	RED	ON	Buffer overflow of received data
LED TX and RX	RED	Flashing, simultaneous	Overload of the port supply. Both LEDs of the corresponding port are flashing simultaneously.
	RED	Flashing, alternating	Configuration error. Both LEDs of the corresponding port are alternately flashing.

LED	Color	Status	Description
IN1/IN2	GREEN	ON	Input active
	RED	Flashing	Overload of the port supply. Both LEDs of the corresponding port are flashing.
		OFF	Input of output inactive
C3/IN2	WHITE	Flashing	Blink/Wing command active

## Dimensions

**Note:**



- All dimensions are in millimeters [inches] and are for reference purposes only.
- All specifications are for reference purpose only, and may be changed without notice.

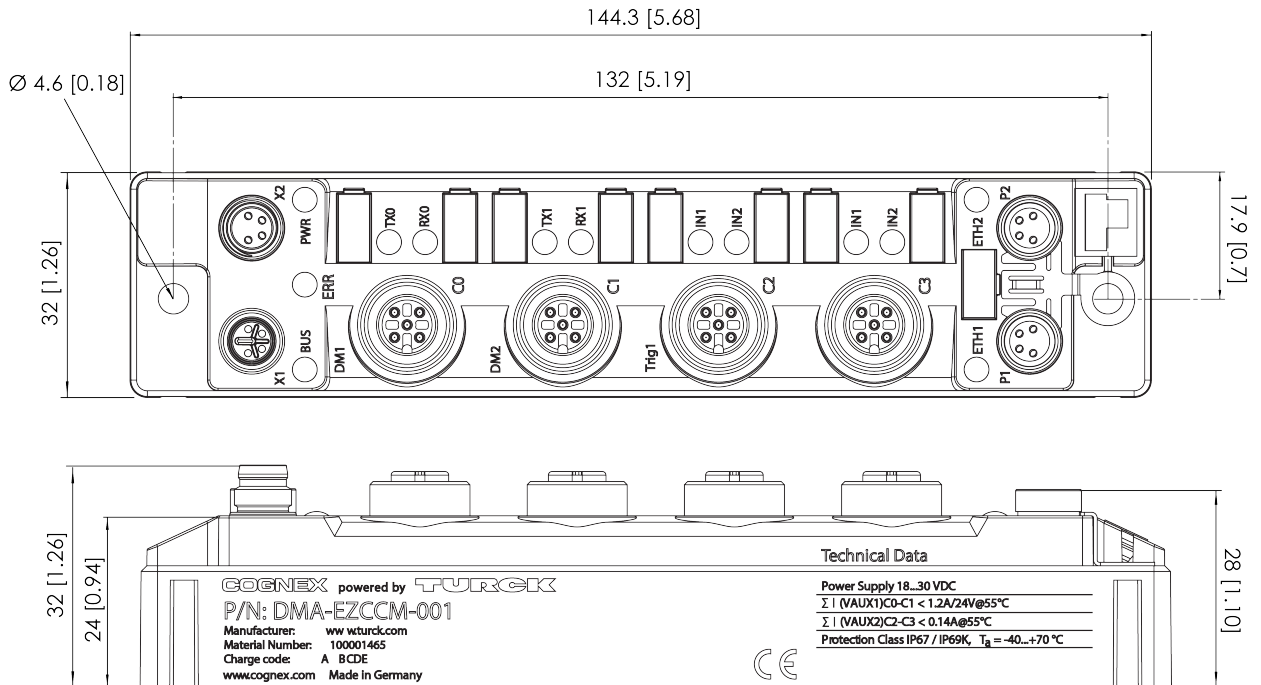

## Accessories

Dataman Cable for DM70 & DM150 - 3 meter* *use also DMA-SERIAL-IP65-ST in combination with DM70	DMCB-EZCCM-DB15-03	
Dataman Cable for DM260, DM300 & DM470 - 3 meter	DMCB-EZCCM-M12-03	
EZCCM Ethernet Cable M8/M8 - 10 meter	DMCB-EZCCM-1011-10	
EZCCM Ethernet Cable M8/RJ45 - 10 Meter	DMCB-EZCCM-1012-10	
EZCCM Power Cable M8/M8 - 10 meter	DMCB-EZCCM-2011-10	
EZCCM Power Cable M8/Flying Leads - 10 meter	DMCB-EZCCM-2013-10	

## Mounting

The device can be mounted on a DIN rail according to EN 60715 (TS35) or screwed onto a mounting plate. Both composite and individual assembly are possible.

### Mounting Module Composites

The TBNN-S0...<sup>1</sup> adapters can be used to build module composites for group assembly.

#### Mounting on Mounting Plate

The devices are fixed on a pre-drilled mounting plate with two M4 screws. The spacers TBNN-S0-STD<sup>2</sup> are necessary for mounting module composites.

Mount the modules or the module composites according to the image below.

1. Unlock the cover flap with a flat tool (e.g. screw driver).

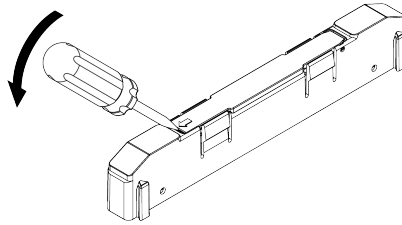

2. Open the flap completely.

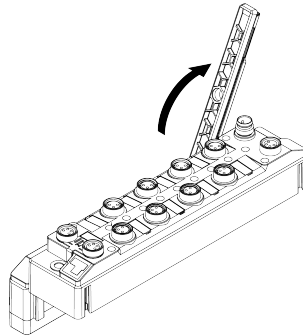

3. To join the DMA-EZCCM-001 module and the spacer, insert the key of the spacer into the slot of the DMA-EZCCM-001 module.

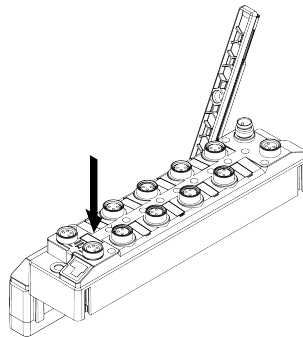

<sup>1</sup> TBNN-S0 is not a Cognex accessory, please contact Turck for more information.

<sup>2</sup> TBNN-S0-STD is not a Cognex accessory, please contact Turck for more information.

4. Flap back the cover and close it. It must engage audibly.

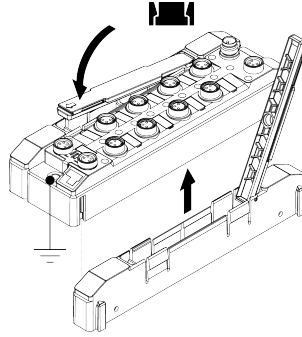

5. Repeat steps 1 to 4 until the module group is complete.

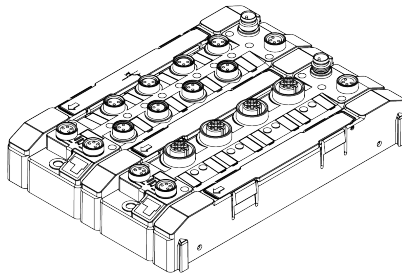

6. Mount the modules or the module composites according to the image below.

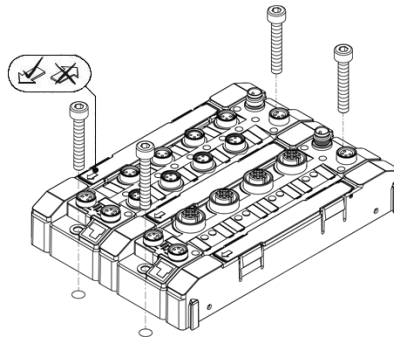

### Mounting on a DIN rail (TS 35)

Single modules or module composites can be mounted on a DIN rail (TS 35) using the spacers TBNN-S0-DRS<sup>1</sup>

**CAUTION:** Incorrect mounting malfunction due to faulty grounding:



- Orient the spacers so that the arrow in the cover flap of every spacer points in direction to the M8 Ethernet connectors
- Connect the grounding contact of the spacer to the grounding contact of the device

<sup>1</sup> TBNN-SO-DRS is not a Cognex accessory, please contact Turck for more information.

1. Unlock the cover flap with a flat tool (e.g. screw driver).

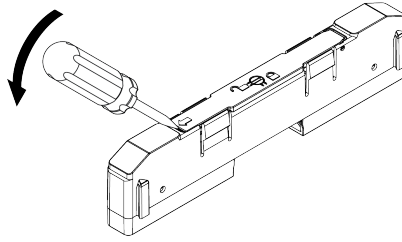

2. Open the flap completely.

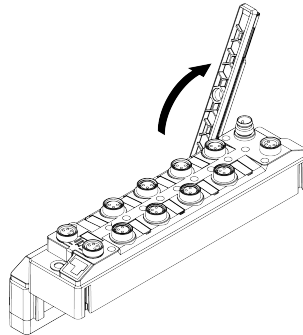

3. To join the EZCCM-module and the spacer, insert the key of the spacer into the slot of the EZCCM-module (3).

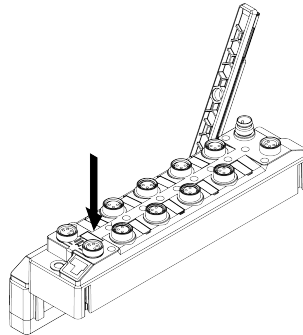

4. Flap back the cover and close it. It must engage audibly.

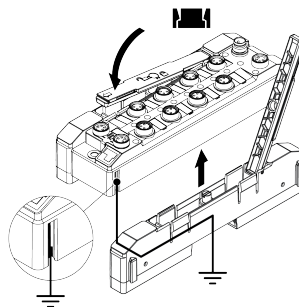

- Repeat steps 1 to 4 until the module group is complete.

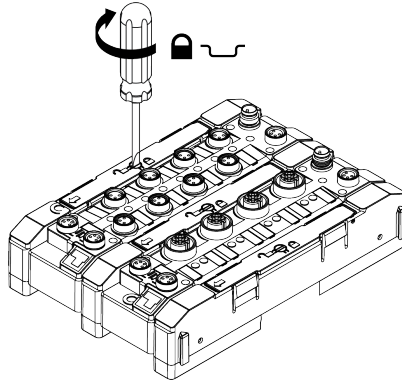

- Mount spacers on the right and the left side of the device.
- Place the device or the composite on the DIN rail so that the cut-outs in the spacers enclose the DIN rail (1).

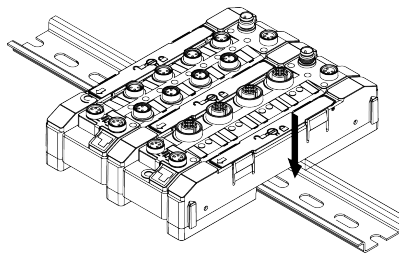

- Close the rotating pin in the spacers by means of a screw driver.
- Ground the device.

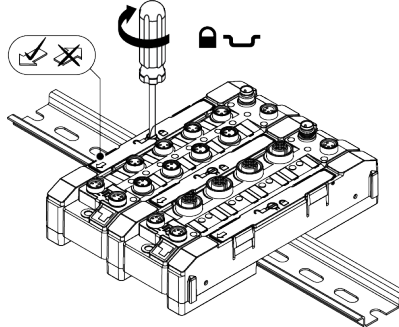

**Note:** To increase stability on the mounting rail, end brackets can be mounted on the left and right side of the modules/module composites.

## Grounding

### Grounding and Shielding Concept

Field bus and I/O part of the DMA-EZCCM-001 modules can be grounded separately.

- The grounding clamp at the M8 connectors for the fieldbus connection (P1, P2) connects the shield of the fieldbus lines.
- The grounding ring leads the shield at the flange of the M8 connectors for the fieldbus connection via an RC-circuit to the outside of the station.
- By mounting the module onto a mounting plate through the mounting hole, the module is connected to the reference potential of the installation by a metal screw.

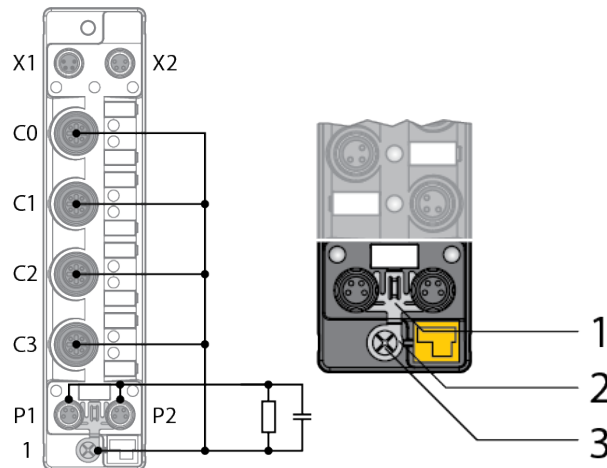

4. The spacers TBNN-S0-DRS<sup>1</sup> for mounting the DMA-EZCCM-001 modules onto a DIN rail (TS 35) connect the grounding contact of the modules with the DIN rail and thus with FE.

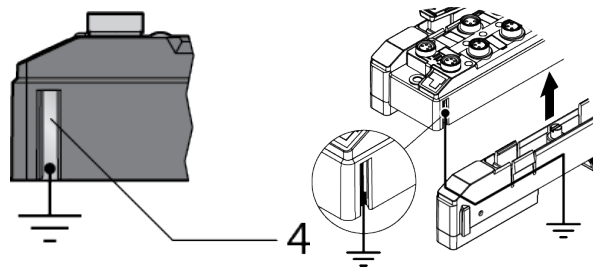

## Ground the Device (FE)

To shield the network cables from possible noise interference the flange of the M8 connectors needs to be at the reference potential of the installation.

This is done through the grounding ring and clamp that are mounted on the device by default and which need to be connected with a metal screw when mounting on a DIN rail.

### Removing the Grounding Clamp

Use a flat screwdriver to slide the grounding clamp forward and remove it.

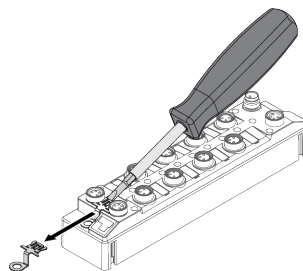

### Mounting the Grounding Clamp

Insert the grounding clamp between the fieldbus connectors (using a screwdriver if necessary) so that it contacts the metal housing of the connector.

The shielding of the fieldbus lines is now connected to the grounding clamp.

<sup>1</sup> TBNN-S0-DRS is not a Cognex accessory, please contact Turck for more information.

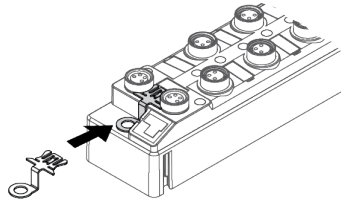

## Connecting

### Supply Concept

All DMA-EZCCM-001 modules are supplied via two separate voltages V1 and V2. The I/O-channels are separated into the different potential groups. This allows a safety shutdown of parts of an installation via emergency-off circuits.

V1 = supply for DataMan Readers

V2 = supply of the respective connectors

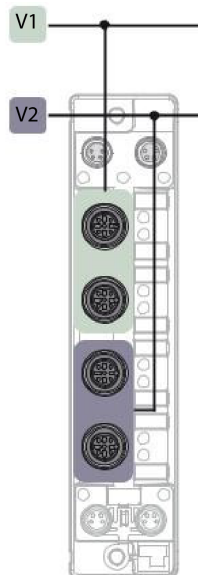

### Connecting the modules to Ethernet

The DMA-EZCCM-001 module is provided with an integrated auto crossing switch with two 4-pin M8 Ethernet plug connectors for connecting to the fieldbus.

**CAUTION:**

Observe using the correct M8-connectors when connecting Ethernet- and power cables (Ethernet: P1 and P2, power: X1 and X2). Interchanging the Ethernet and the power cables can destruct the internal electronics.

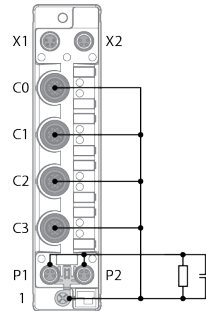

Connect the device to Ethernet according to the pin assignment below.

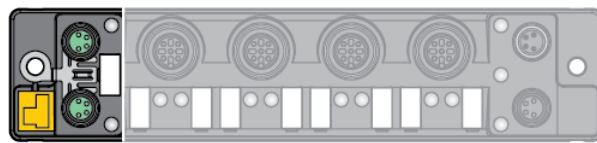

P1

P2

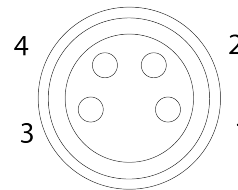
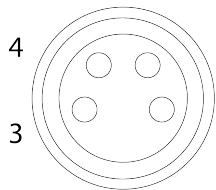

- 1= TX+
- 2= RX+
- 3= RX-
- 4=TX-

- 1= RX+
- 2= TX+
- 3= TX-
- 4= RX-

## Connecting Power Supply

The DMA-EZCCM-001 module is provided with two 4-pin M8 plug connectors for connecting the power supply. V1 and V2 are galvanically isolated.

**CAUTION:**

Observe using the correct M8-connectors when connecting Ethernet- and power cables (Ethernet: P1 and P2, power: X1 and X2). Interchanging the Ethernet and the power cables can destruct the internal electronics.

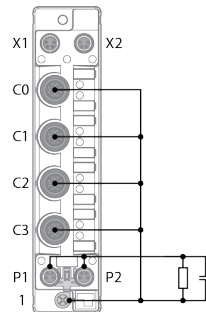

Connect the device to the voltage supply according to the pin assignment below.

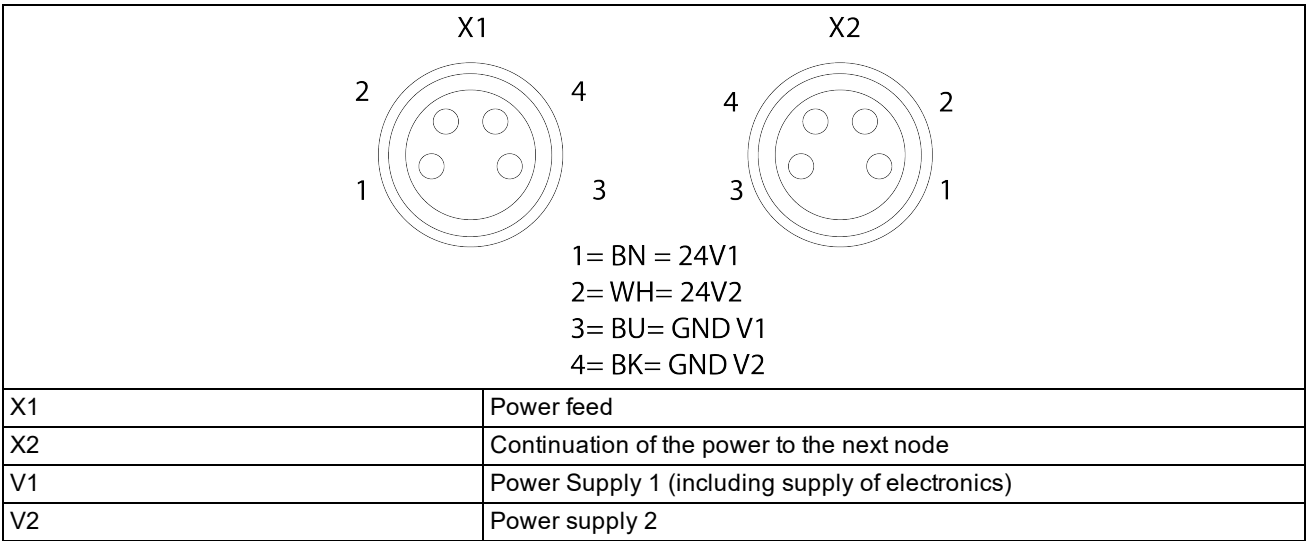
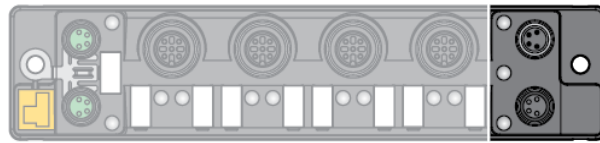

**Note:** The system voltage (V1) and the load voltage (V2) are fed in and monitored separately. In case of an undercut of the admissible voltage, the connectors are switched off according to the module's supply concept. In case of an undervoltage at V2, the LED PWR changes from green to red. In case of an undervoltage at V1, the led is turned off.

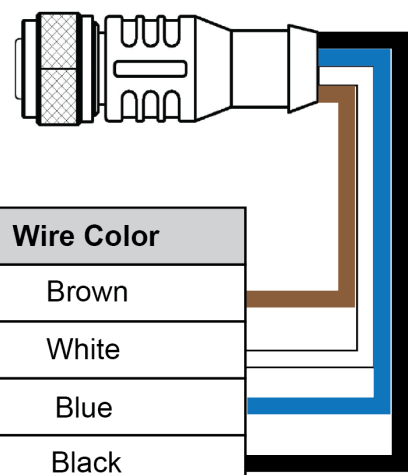

Pin #	Signal Name	Wire Color
1	24V-V1	Brown
2	24V-V2	White
3	GND-V1	Blue
4	GND-V2	Black

### Connecting Digital Sensors

The DMA-EZCCM-001 module is provided with two 5-pin M12 connectors for connecting digital sensors, which can act as trigger to the DataMan readers or general inputs to read out via fieldbus.

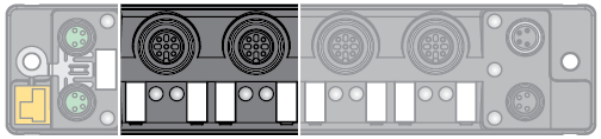

Connect the sensors to the device according to the pin assignment shown below.

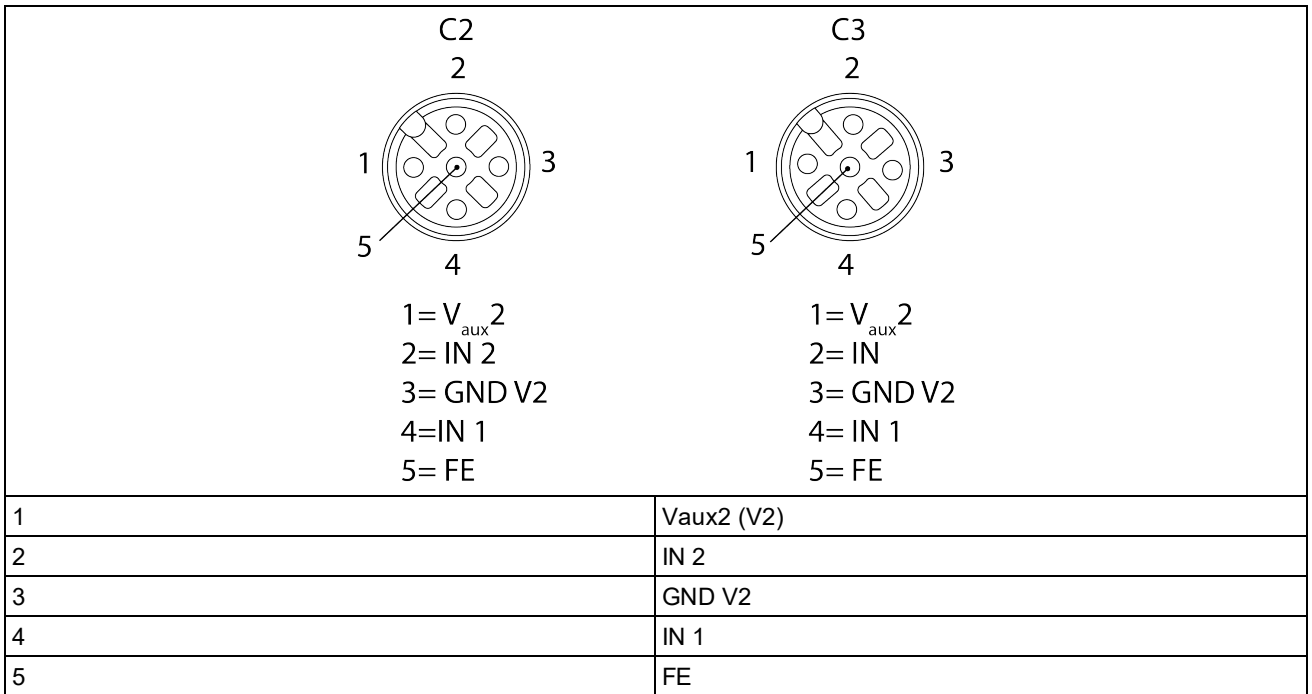

### Connecting DataMan Readers

The DMA-EZCCM-001 module is provided with two 5-pin M12 connectors for connecting DataMan Readers.

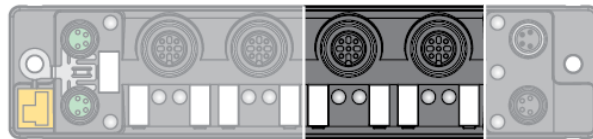

### Connecting DataMan 70 Series

To connect DataMan 70 series to the DMA-EZCCM-001, two cables are required:

- DMA-SERIAL-IP65-ST
- DMCB-EZCCM-DB15-03



### Connecting DataMan 150 Series

To connect DataMan 150 series to the EZCCM a connection accessory is required:

- DMCB-EZCCM-DB15-03



### Connection DataMan 260 / 300 / 470 Series

To connect DataMan 260, 300 or 470 Series a connection accessory is required.

- DMCB-EZCCM-M12-03



Images shows connection to DM 260 reader.

# Getting Started

The module automatically starts after the electrical wiring and connecting the supply voltage.

## Setting IP Address

In the delivery state the module has the IP address 192.168.1.254. A device name has not yet been assigned. The IP address can be set via DataMan Setup Tool, web interface, a DHCP server or PROFINET DCP. In the following example, the IP address is set by Cognex Setup Tool.

- Connect the DMA-EZCCM-001 to a PC via the Ethernet interface.
- Open DataMan Setup Tool.
- Go to Repair & Support tab and select which discovered device you want to setup
- In the right pane configure the IP details for the device

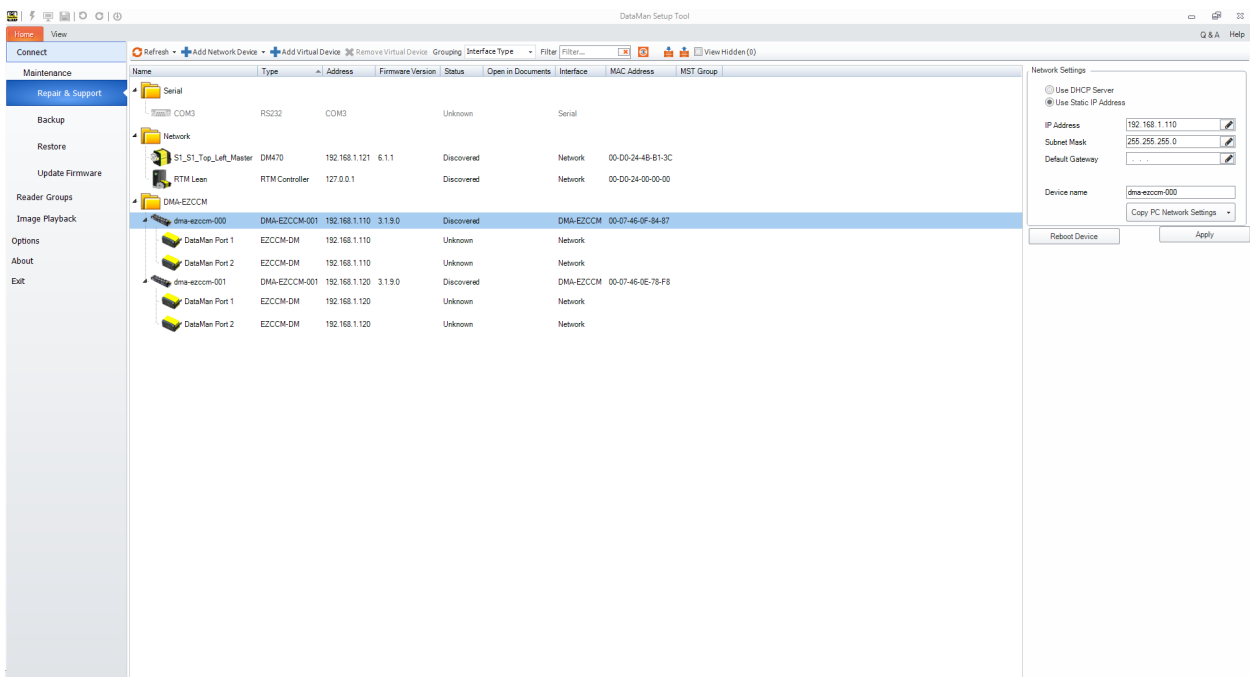

## Setup Tool Connection

Each DMA-EZCCM-001 can control two DataMan readers, which are automatically added to the list when a module is discovered. When connecting to the device, Setup Tool tunnels through the DMA-EZCCM-001 to the DataMan reader.

**CAUTION:** The DMA-EZCCM-001 will go into “setup mode” when a Setup Tool connection is opened. In Setup Mode the DMA-EZCCM-001 will not process any trigger requests, soft events or read results. The PLC is notified whether the DMA-EZCCM-001 operates in “run” or “setup mode”. The DMA-EZCCM-001 switches automatically back to run mode once Setup Tool is closed. The PLC can also prohibit a Setup Tool connection by forcing the DMA-EZCCM-001 to run mode.

Data and control are fully complaint like it would be through a Ethernet or USB connection.

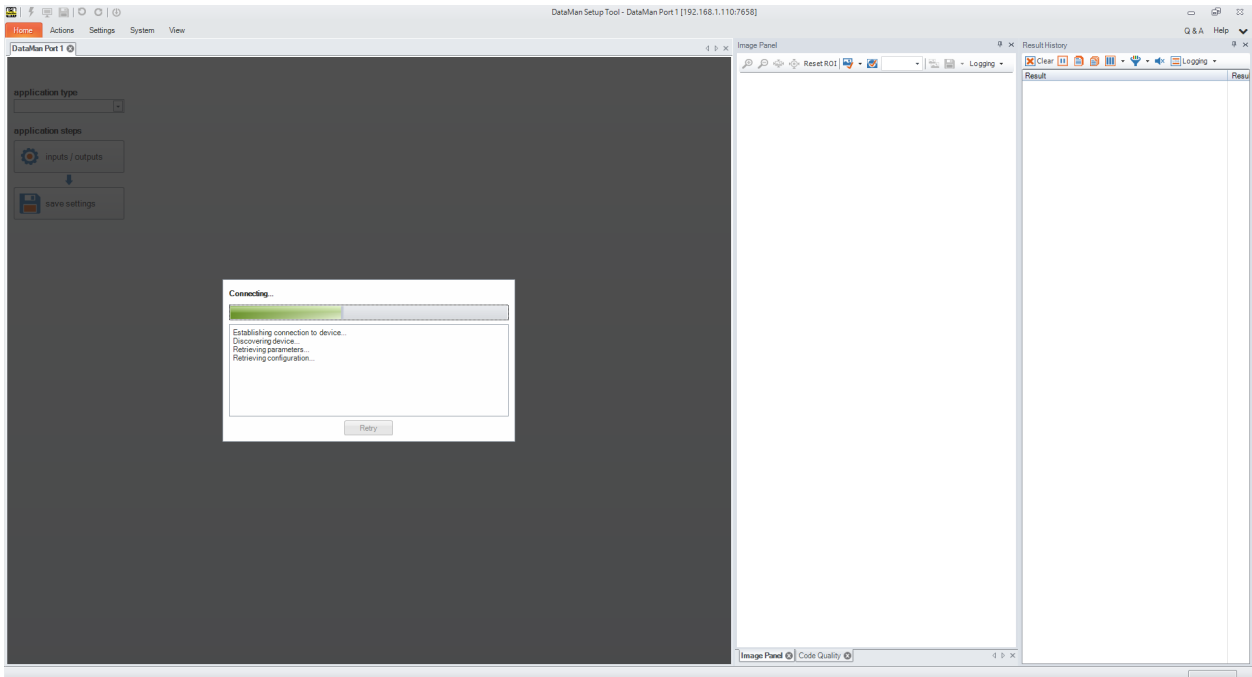

## Web GUI

When double clicking the discovered Daisy chain device, your default browser will open and show you a webserver link of the device. Here you have the possibility to see the details and data structure of the device.

A separate view with the "Dataman Reader Status" is also available to you.

Here you can find information about the Control and Status bits and bytes of reader data.

tml



Station Information



TURCK.COM For comments or questions, please email TURCK Support

## DMA-EZCCM-001

## DATAMAN READER STATUS &gt;

STATION &gt;

COM 0 &gt;

RS DATA/SCB 0.0 &gt;

RS DATA/SCB 0.1 &gt;

RS DATA/SCB 0.2 &gt;

RS DATA/SCB 0.3 &gt;

RS DATA/SCB 0.4 &gt;

RS DATA/SCB 0.5 &gt;

RS DATA/SCB 0.6 &gt;

RS DATA/SCB 0.7 &gt;

COM 1 &gt;

RS DATA/SCB 1.0 &gt;

RS DATA/SCB 1.1 &gt;

RS DATA/SCB 1.2 &gt;

RS DATA/SCB 1.3 &gt;

RS DATA/SCB 1.4 &gt;

RS DATA/SCB 1.5 &gt;

RS DATA/SCB 1.6 &gt;

RS DATA/SCB 1.7 &gt;

COM DIAGNOSTICS &gt;

MB-SERVER STATUS &gt;

MB-SERVER TIMING &gt;

DXP &gt;

DXP DIAGNOSTICS &gt;

EXT. DXP FUNCTIONS 4 &gt;

EXT. DXP FUNCTIONS 5 &gt;

EXT. DXP FUNCTIONS 6 &gt;

EXT. DXP FUNCTIONS 7 &gt;

## Station Information

## Station Information

Type	DMA-EZCCM-001
Identification Number	100001465
Firmware Revision	V3.1.9.0
Bootloader Revision	V9.0.1.0
EtherNet/IP™ Revision	V2.7.21.0
PROFINET Revision	V1.6.0.1
Modbus TCP Revision	V2.2.2.0
Addressing Mode	PGM DHCP
PROFINET Station Name	dma-ezccm-000
ARGEE Boot Project	Running
ARGEE Project Title	DMA_EZCCM_001_V1_33_0_0
ARGEE Factory Programmed	No

## Network Settings

Ethernet Port 1 setup	Autonegotiate
Ethernet Port 2 setup	Autonegotiate
IP Address	192.168.1.110
Netmask	255.255.255.0
Default Gateway	0.0.0.0
MAC Address	00:07:46:0f:84:87
LLDP MAC Address 1	00:07:46:0f:84:88
LLDP MAC Address 2	00:07:46:0f:84:89

## EtherNet/IP™ Status

Network topology	Linear
DLR State	Normal
QuickConnect	Disabled

## PROFINET Status

Network topology	Linear
FastStartUp	Disabled



Screens  
Reader Status

Channel 1: COMM/PLC Status		Channel 2: COMM/PLC Status	
PLC State	Connected	PLC State	Connected
Serial Error (IN)	No Error Reader Connected	Serial Error (IN)	Connection Lost...
DMA-EZCCM-001 Mode (IN)	Run Mode	DMA-EZCCM-001 Mode (IN)	Run Mode
Force Run Mode (OUT)	Allow to open Setup Tool Connection	Force Run Mode (OUT)	Allow to open Setup Tool Connection
Channel Payload Size	16 bytes	Channel Payload Size	16 bytes
Total Channel Size	24 bytes	Total Channel Size	24 bytes
Fieldbus Trigger State		Fieldbus Trigger State	
Trigger Enable (OUT)	Trigger via PhotoEye	Trigger Enable (OUT)	Trigger via PhotoEye
Trigger Ready (IN)	Not Ready to Accept Trigger via Fieldbus	Trigger Ready (IN)	Not Ready to Accept Trigger via Fieldbus
Trigger (OUT)	Trigger OFF	Trigger (OUT)	Trigger OFF
Fieldbus Trigger Ack (IN)	0	Fieldbus Trigger Ack (IN)	0
DXP Trigger State		DXP Trigger State	
DXP Pin 4 Current State (IN)	0	DXP Pin 4 Current State (IN)	0
DXP Pin 2 Current State (IN)	0	DXP Pin 2 Current State (IN)	0
Trigger Setting (OUT)	Individual Triggers per Channel	Trigger Setting (OUT)	Individual Triggers per Channel
Trigger Pin (OUT)	Pin 4	Trigger Pin (OUT)	Pin 4
Trigger Edge (OUT)	Rising Edge	Trigger Edge (OUT)	Rising Edge
Trigger Status		Trigger Status	
Acquiring (IN)	Reader Idle	Acquiring (IN)	Reader Idle
Missed Trigger (IN)	No Error	Missed Trigger (IN)	No Error
Results Available (IN)	No	Results Available (IN)	No
Number of Results (IN)	0	Number of Results (IN)	0
Next Trigger ID (IN)	0	Next Trigger ID (IN)	0
Result ID (IN)	0	Result ID (IN)	0
Soft Event Status		Soft Event Status	
Soft Event Code (OUT)	No Soft Event in progress	Soft Event Code (OUT)	No Soft Event in progress
Soft Event Error Code (IN)	0	Soft Event Error Code (IN)	0
Soft Event Ack (IN)	0	Soft Event Ack (IN)	0
User Data Option (OUT)	0	User Data Option (OUT)	0
User Data Length (OUT)	0	User Data Length (OUT)	0
User Data (OUT)		User Data (OUT)	
Result/Soft Event Response		Result/Soft Event Response	
Result Code (IN)	Trigger Result	Result Code (IN)	Trigger Result
Result Data/Soft Event Response Length (IN)	0	Result Data/Soft Event Response Length (IN)	0
Result Data/Soft Event Response Data (IN)		Result Data/Soft Event Response Data (IN)	

Legend:  
(OUT) - PLC->DMA-EZCCM-001  
(IN) - DMA-EZCCM-001->PLC

## Memory Mapping

The memory mapping consists of two blocks of which size will be variable depending on the data block size:

Input is viewed from PLC perspective and shows data from DMA-EZCCM-001 -> PLC

	Status	Result Data	Total Size
INPUT	8 bytes	16 bytes	24 bytes
		32 bytes	40 bytes
		64 bytes	72 bytes
		136 bytes	144 bytes
		232 bytes	240 bytes

Byte	Description	Bit	Description	Comment
0	Trigger Status	0	Trigger Ready	0 = Not Ready to Accept Trigger via Fieldbus (state when Trigger Enable is low or currently processing trigger or soft event) 1 = Ready to Accept new Trigger via Fieldbus
		1	Trigger Ack	Confirmation of receiving Trigger ON bit, stays on until Trigger bit is low
		2	Acquiring	0 = Reader Idle 1 = Reader Processing a trigger (whether it came from photo eye or fieldbus)
		3	Missed Trigger	0 = No Error 1 = Received a trigger (signal from Photo Eye or Field bus) when an other trigger or soft event is processing. Will reset automatically when a successful trigger could be processed again.
		4	Current Mode	0 = Setup Tool Mode 1 = Run Mode
		5	Serial Error	0 = No Error; Reader is Connected 1 = No Reader connected
		6	Trigger Pin 4 Current State	Copy state of input line IN 1
		7	Trigger Pin 2 Current State	Copy state of input line IN 2
1	Result Status	0	Results Available	Indicates that a new set of read results are available (i.e. the contents of the Result Data are valid). Cleared when results are acknowledged by PLC
		1	Result Ack mirror	This bit mirrors the state of the "Results Ack" bit from the output data. This is not exactly "Result Data Valid". When the result data is first presented, this bit will still be "0," since it just mirrors the "Results Ack" bit from the last output but the data is valid.
		2	Result Data Buffer Overrun	
		3		
		4		
		5		
		6		
		7	General Fault	Indicates that a fault has occurred (currently reports V1 or V2 undervoltage)
2	Soft Event Status	0 ... 6	Soft Event Error Code	Soft event error code from DMCC Error code 127 - timeout
		7	Command Completed or Timed out	
3	ResultCode	0 ... 7		0 - Trigger result 1 - SoftEvent Command is running 2- SoftEvent Command Complete
4	TriggerID	0..7		ID value of the next trigger to be issued. Used to match issues triggers with corresponding result data received later.
5	ResultID	0.7		The value of the "Trigger ID" counter when the trigger that generated these results was issued.
6	ResultLength	0..7		Actual number of bytes contained in the "Result Data" field

Byte	Description	Bit	Description	Comment
7	Data Block Size ACK	0 ... 3	Data Block Size Ack	0 = 16 bytes (default) 1 = 32 bytes 2 = 64 bytes 3 = 136 bytes 4 = 232 bytes
		4		
		5		
		6		
		7	Reader 2 Disabled	0 = Reader 2 Enabled (default) 1 = Reader 2 Disabled
8 ... 239	ResultData	---		

Output is viewed from PLC perspective and shows data from PLC -> DMA-EZCCM-001

	Control	User Data	Total Size
OUTPUT	8 bytes	16 bytes	24 bytes
		32 bytes	40 bytes
		64 bytes	72 bytes
		136 bytes	144 bytes

Byte	Description	Bit	Description	Comment
0	Trigger Control	0	Trigger Enable	0 = Trigger via PhotoEye 1 = Trigger via Fieldbus
		1	Trigger	0 = Trigger OFF 1 = Trigger ON * only when Trigger Enable == 1
		2		
		3		
		4	Force Run Mode	0 = Allow to open Setup Tool Connection 1 = Block Setup Tool Connection and stay in Run Mode
		5	Trigger Setting	0 = Individual Trigger per reader 1 = Trigger = triggers both readers * Only for Trigger 2
		6	Trigger Pin	0 = Pin 4 IN1 1 = Pin 2 IN2
		7	Trigger Edge	0 = Rising edge 1 = Falling edge
1	Result Control	0	Results Ack	Bit is used to acknowledge that the PLC has successfully read the last result data. When set to true the 'Result Available' bit will be cleared.
		1		
		2		
		3		
		4		
		5		
		6		
		7		

Byte	Description	Bit	Description	Comment
2	Soft Event Control	0	Soft Event Train Code	
		1	Soft Event Train Match String	
		2	Soft Event Focus	
		3	Soft Event Train Brightness	
		4	Soft Event Untrain	
		5	Soft Event Set Input String	
		6	Soft Event Execute DMCC	
		7	Soft Event Set Match String	
3	UserDataOption	0 ... 7		Only used by "Set Match String" soft event. Specifies which code target to assign the string (16-bit integer)
4		0 ... 7		
5		0 .. 7		
6	UserDataLength	0 .. 7		Actual number of bytes contained in the "User Data" field
7	Data Block Size	0 ... 3	Data Block Size Enumeration	0 = 16 bytes (default) 1 = 32 bytes 2 = 64 bytes 3 = 136 bytes 4 = 232 bytes
		4		
		5		
		6		
		7	Reader 2 Disabled	0 = Reader 2 Enabled 1 = Reader 2 Disabled
8 ... 239	UserData	---		

## Setup Device

### Flexible Memory Configuration

- The DMA-EZCCM-001 can hold up to 2 connected devices
- It will allow different data size configurations for better PLC memory allocation
- For multiple readers connected, the size will be equal between the two devices
- "Data Block Size Enumeration" in "Data Block Size" byte setups the size of the User/Result Data Arrays
- "Disable Reader 2" in "Data Block Size" Enables/Disable control of the second reader to be used in the logic
- The starting data byte of the second reader depends on the selected Data Block size and is as follows:

Byte Ch1	Byte Ch2/16	Byte Ch2/32	Byte Ch2/64	Byte Ch2/136	Byte Ch2/232
0	24	40	72	144	240

### Identify Reader Connection

- Setup Tool will automatically broadcast to find the DMA-EZCCM-001 over the network
- The "Serial error" bit in "Trigger Status" byte will indicate when the reader is down or the connection is broken.

## Triggering Readers

Trigger via Photoeye:

- Port C2 corresponds to C0 input of the reader.
- Port C3 corresponds to C1 input of the reader.
- Each port has two different physical inputs that can be used PIN 2 / PIN 4.
- This selection can be made with “Trigger PIN” bit in “Trigger Control”.
- The trigger point on PE could be executed either on Leading or Trailing edge of the signal.
- This selection can be made with “Trigger Edge” bit in “Trigger Control”.
- There is a “Trigger Settings” bit that allows the two readers to be triggered simultaneously from one PE point from port C0.

Trigger via Fieldbus:

- Triggering can be executed from Profinet and Ethernet/IP.
- For that, the “Trigger Enable” bit should be true.
- When that bit will be true, the PE signals will not be considered, but signals can be read out via fieldbus for other purposes.
- The trigger point on industrial network could be executed either on Leading or Trailing edge of the signal.
- This selection can be made with “Trigger Edge” bit in “Trigger Control”.

## Reading Results

With each executed trigger on which the readers have data available, the details will be updated on the memory mapping of that reader:

- “Result Status” byte will indicate result data details
- “Result Code” will outline what is the cause of the result (read/ special commands)
- “Trigger ID” will indicate the next available trigger number available
- “Result ID” will have the index of the current available data
- “Result Length” is the amount of data available in the “Result Data” block
- “Result Data” is the actual available data which the reader result outputs

If the reader has a “No read” with an empty result, the above details will not be populated. Therefore it is recommended to have a no-read string set in DataMan Setup Tool.

Because of the speed of serial transmission and trigger queueing, the Daisy chain device has a 10 entry buffer stack which holds the data and passes it to the PLC when PLC is ready to process it.

After each data acquisition, when the “Results available” bit is true, the “Results Ack” bit from “Result Control” needs to be latched after the received data has been processed, to take it out of the buffer.

If the buffer is not cleared in due time it will indicate an error through the “Result Data Buffer Overrun” bit in “Result Status”. This shows that there is no space in the FIFO stack and that data is being lost. The buffer is cleared, when it has at least 1 spare place after a new trigger has been executed, and it has space to upload the data.

## Soft Events

Soft events let the user access the advanced functionality of the reader through special commands that allow access to internal data and parameters of the readers:

- Train Code – triggers the reader and trains the read code;
- Train Match String – triggers the reader and assigns the read code for Match string validation
- Focus – sets the reader through a focus adjustment sequence
- Train Brightness -sets the reader through a brightness adjustment sequence
- Untrain – disables the current trained code
- Set Input String – configures the input string for the serial
- Execute DMCC – sends a DMCC command to the reader
- Set Match String - configures the match string

The last 3 commands use the User data block and details and the following need to be set:

- User Data Option - Currently only used by “Set Match String” soft event. Specifies which code target to assign the string
  - 1: DataMatrix
  - 2: QR Code/MaxiCode/AztecCode
  - 3: Linear/ Postal/ Stacked
  - 4: VeriCode®
  - 5: DotCode
- User Data Length – Size of data in the User Data
- User Data – necessary data to be send

### Set Match String Example

- Select User Data Option e.g. 1
- Set User Data Length e.g. 6
- Write in User Data the Match String you want to use eg. ABC123
- Trigger soft event

### Execute DMCC

- Set User Data Length e.g. 23
- Write Command in User Data like in command reference manual eg. GET DVALID.MATCH-STRING
- Trigger soft event

### Set Input String Example

- Enable Input String with DMCC command e.g. SET INPUT-STRING.ENABLE ON
- Set Input String Footer with DMCC command e.g. SET INPUT-STRING.FOOTER <ETX>
- Set Input String Header with DMCC command e.g. SET INPUT-STRING.HEADER <STX>
- Set User Data Length e.g. 28

- Write in User Data the Input String you want to use eg. SET INPUT-STRING.VALUE <STX>123<ETX>
- Trigger soft event

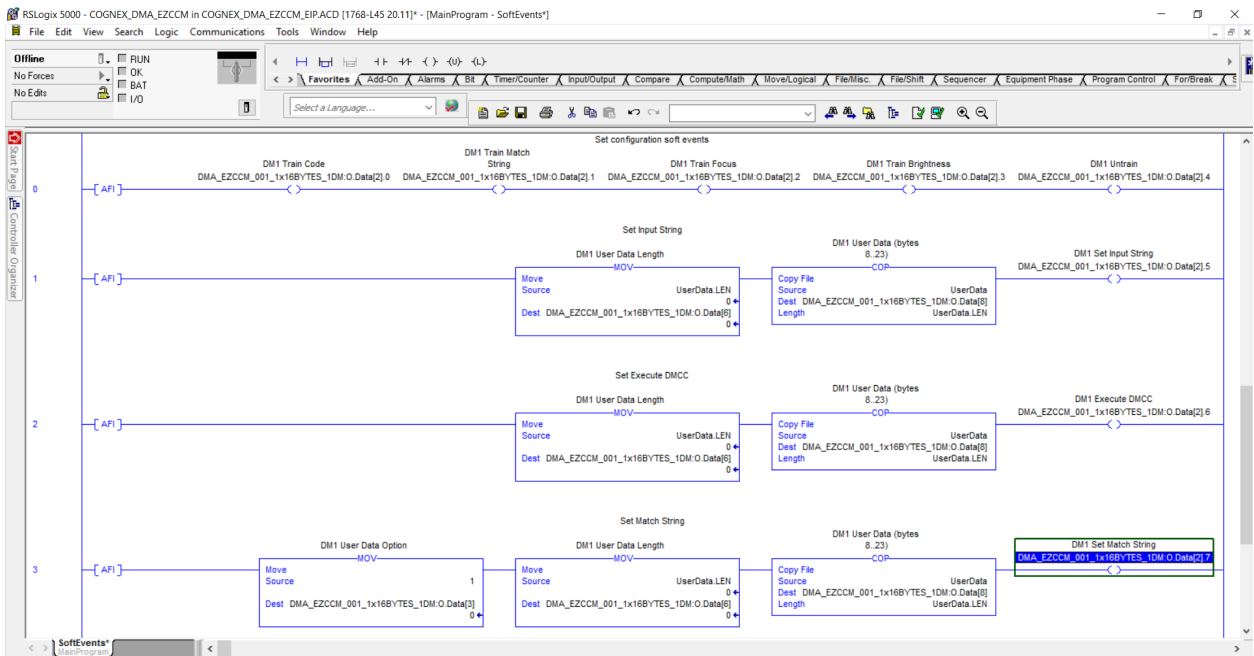

## Advanced Features

- Reading Input Channel
  - The DMA-EZCCM-001 has two input channels and each has 2 input lines, on pin 2 and pin 4.
  - Each of the 4 inputs can be traced back to the PLC so that it tracks any signals coming from the conveyor.
- Blocking ST connection
  - Once the Setup tool will tunnel through the device to connect to a reader, the serial connection for the industrial network connection will be disrupted.
  - To avoid this “Force RUN mode” bit from “Trigger Control” can keep the PLC connection alive and disable the possibility to connect over Setup Tool.

# Connecting

## Connecting the device to a Siemens PLC in PROFINET IO

The following example describes the connection of the devices to a Siemens PLC in PROFINET by means of the programming software SIMATIC TIA Portal V13.

### Used Hardware

The following hardware component is used in this example:

- Siemens PLC S7-1200

### Used Software

The following software tools are used in this example:

- SIMATIC TIA Portal V13
- GSDML file for DMA-EZCCM-001 will be included in the install files of Setup Tool

### Prerequisites

- The programming software has been started.
- A new project has been created.
- The PLC has been added to the project.

### Installing the GSDML-file

Procedure:

1. Click "Options"->"Manage general station description files (GSD)" to add the GSDML-file, and define the source path for the GSDML file in C:\Program Files\Cognex\DataMan\DataMan Software\Tools\Profinet.

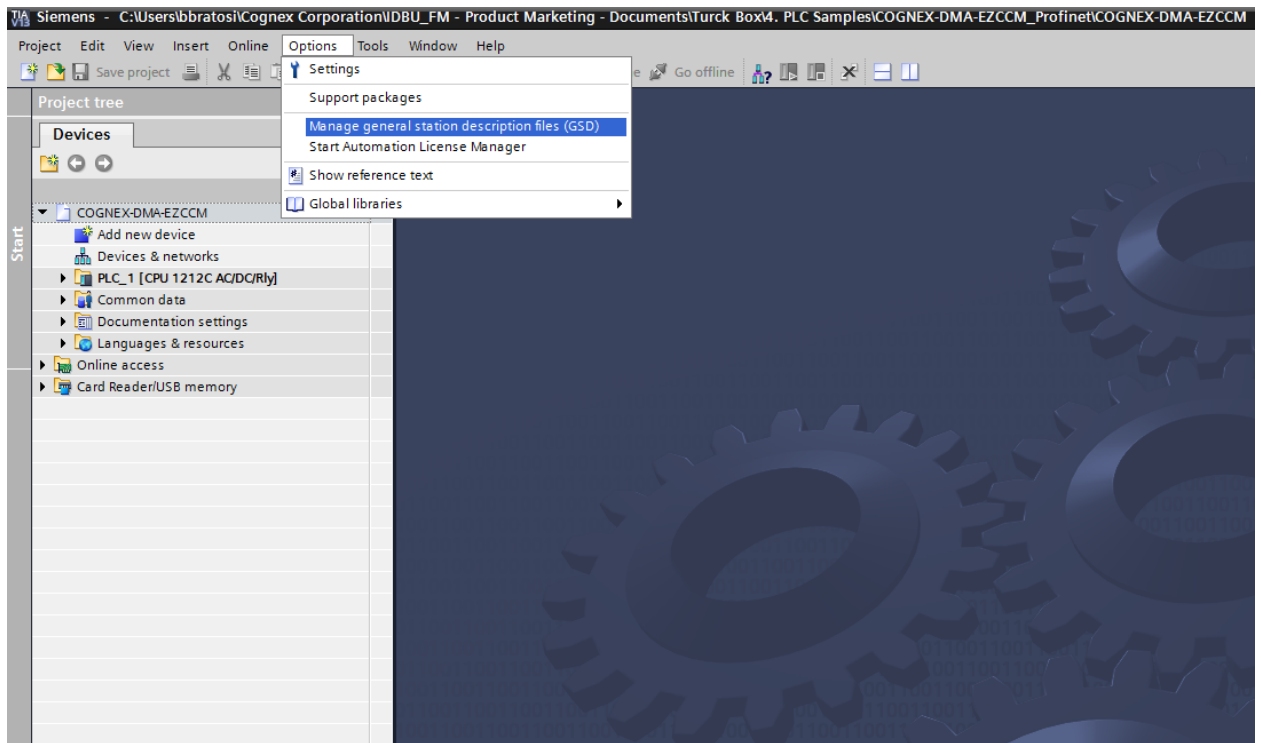

2. Select the GSDML-file to be installed and click "Install". As a result, the device is added to the Hardware catalog of the programming software.

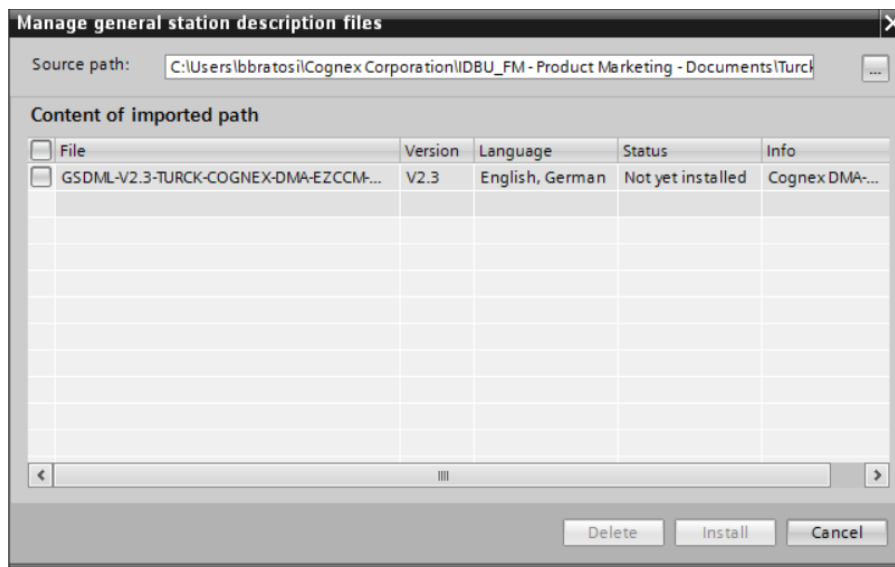

3. Select the DMA-EZCCM-001 from the Hardware catalog and drag it into the "Device & net-works" editor.
4. Configure the device per drag & drop depending on the application.
5. Define the function of the two COM ports (slot 1 and 2) and define the other slots by assigning the suitable sub modules.

**Note:** The PROFINET device model, the sub module functions as well as the possible configuration options are described under PROFINET IO Device Model, page 24 and Structure of the DMA-EZCCM-001, on page 24.

## Slots and Modules

The DMA-EZCCM-001 has a head module and 2 slots where you can add different sizes of INPUT and OUTPUT modules.

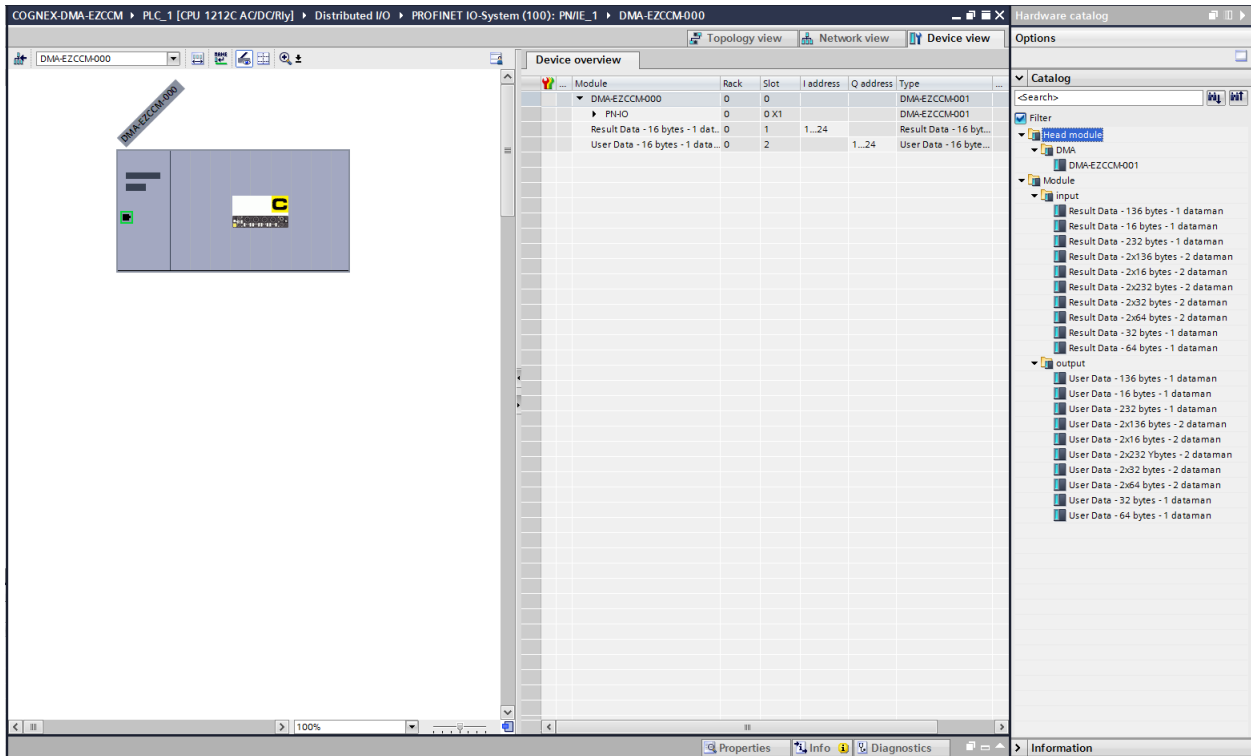

Connecting the device to the PLC:

- Connect the device to the PLC in the "Devices & networks" editor.

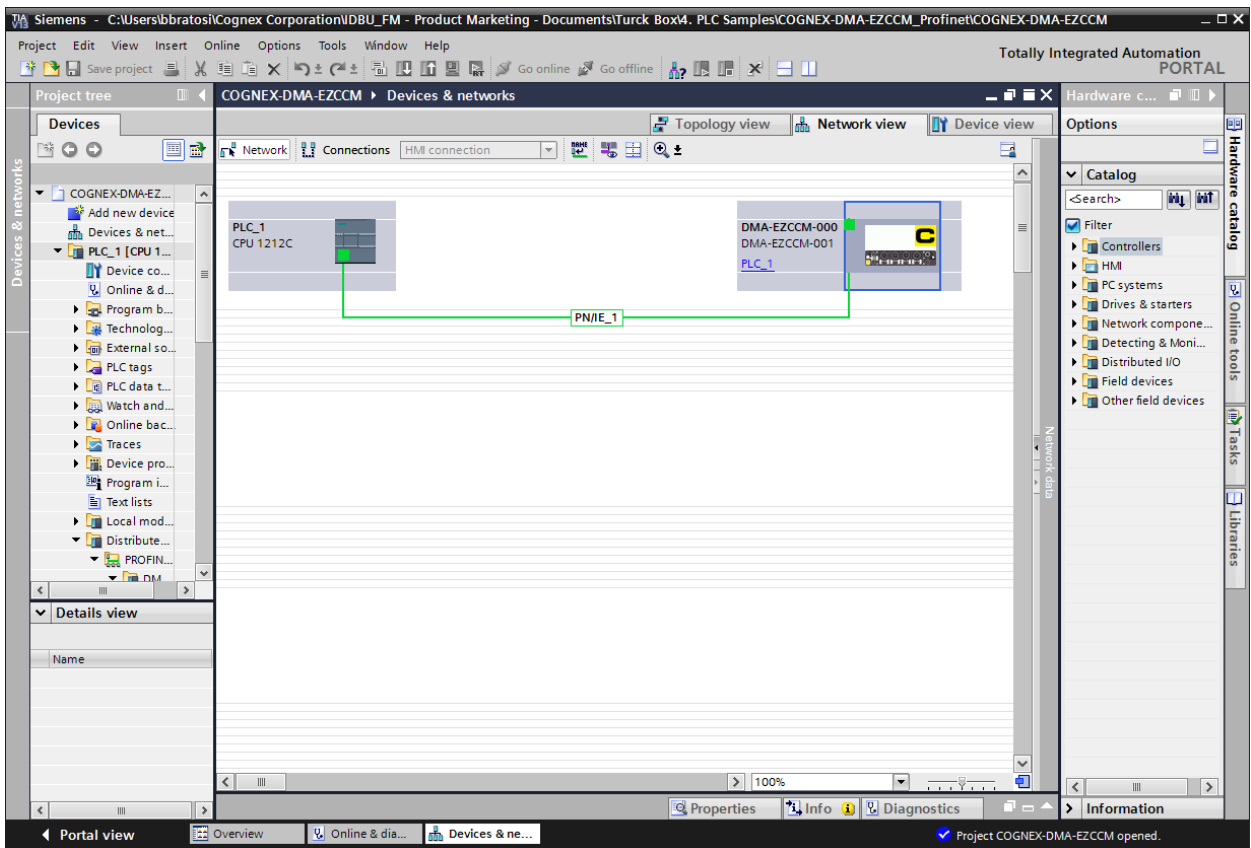

Assigning PROFINET device name:

1. Select "Online access" -> "Online & diagnostics".
2. Select "Functions" -> „Assign name”.
3. Enter the desired PROFINET device name for the device.

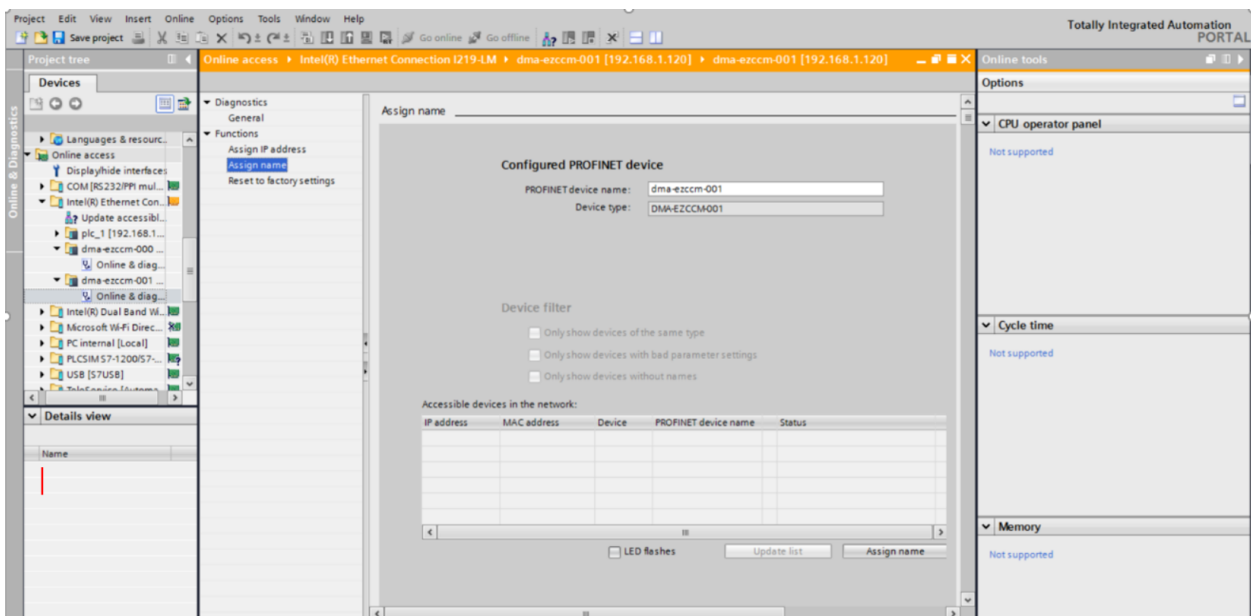

Setting the IP address in TIA Portal:

1. Select the DMA-EZCCM-001 in the "Device view".
2. Select "Ethernet addresses" in the register tab "Properties".
3. Assign the desired IP address.

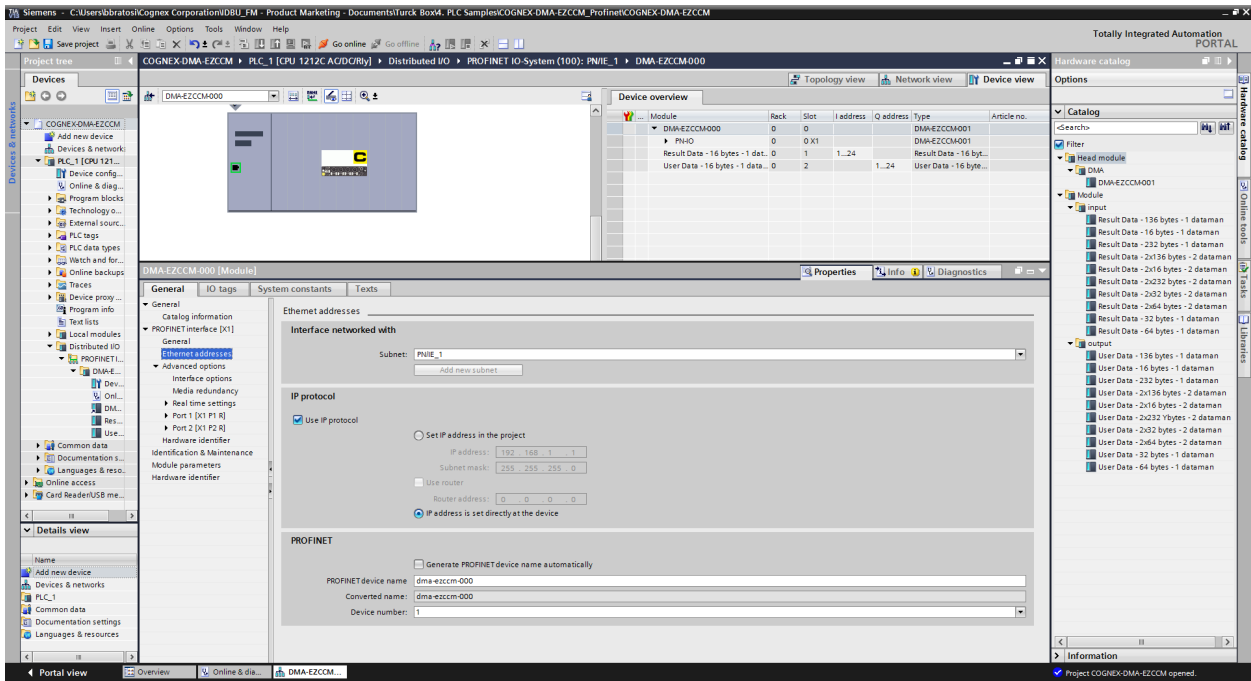

## Connecting the device to an EtherNet/IP™ PLC

The following hardware components are used in this example::

- Rockwell PLC ControlLogix 1756-L60
- Block module

The following software tools are used in this example:

- Rockwell RS Logix
- L5K that is available within the install files of Setup tool

Prerequisites:

- The programming software has been started.
- A new project has been created with the PLC and the Scanner mentioned above.
- The PLC has been added to the project.

## Commissioning the Device in EtherNet/IP™:

Features	Description
Number of TCP connections	1
Number of CIP connections	1
Input Assembly Instance	101
Output Assembly Instance	110
Configuration Assembly Instance	1

## Adding the Prebuilt Generic Ethernet modules

Import the L5K detailed project or open the ACD sample project to find all variation of setups of daisy chain devices.

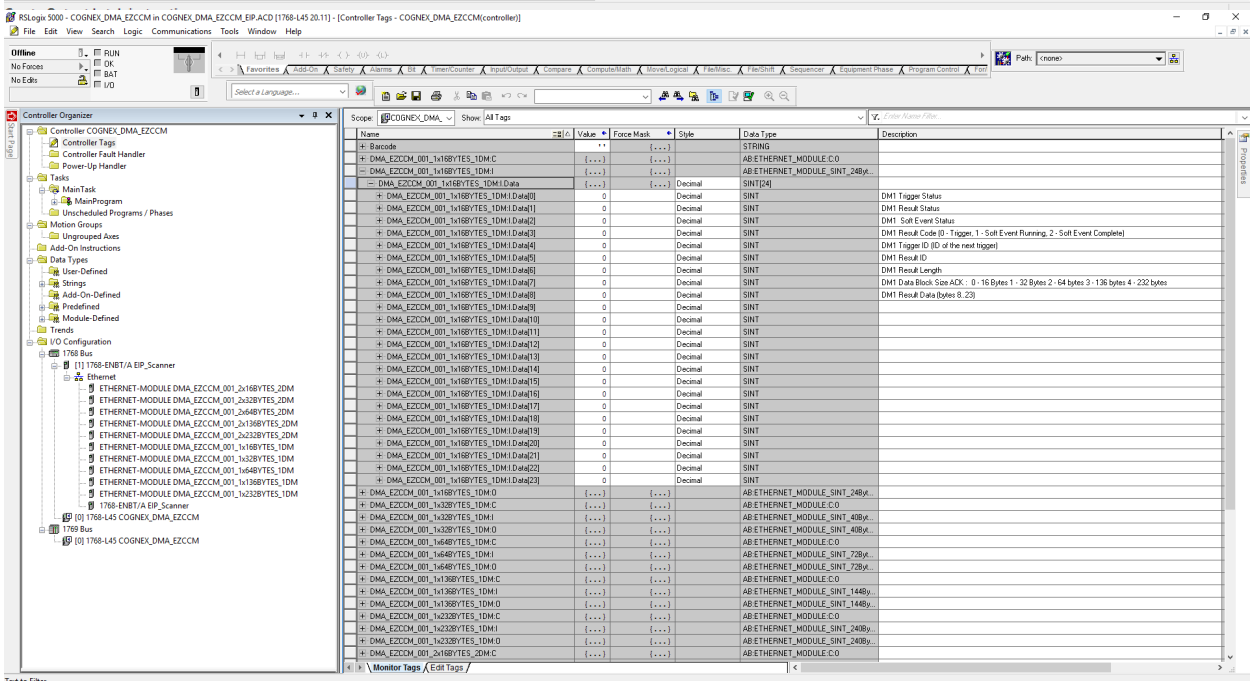
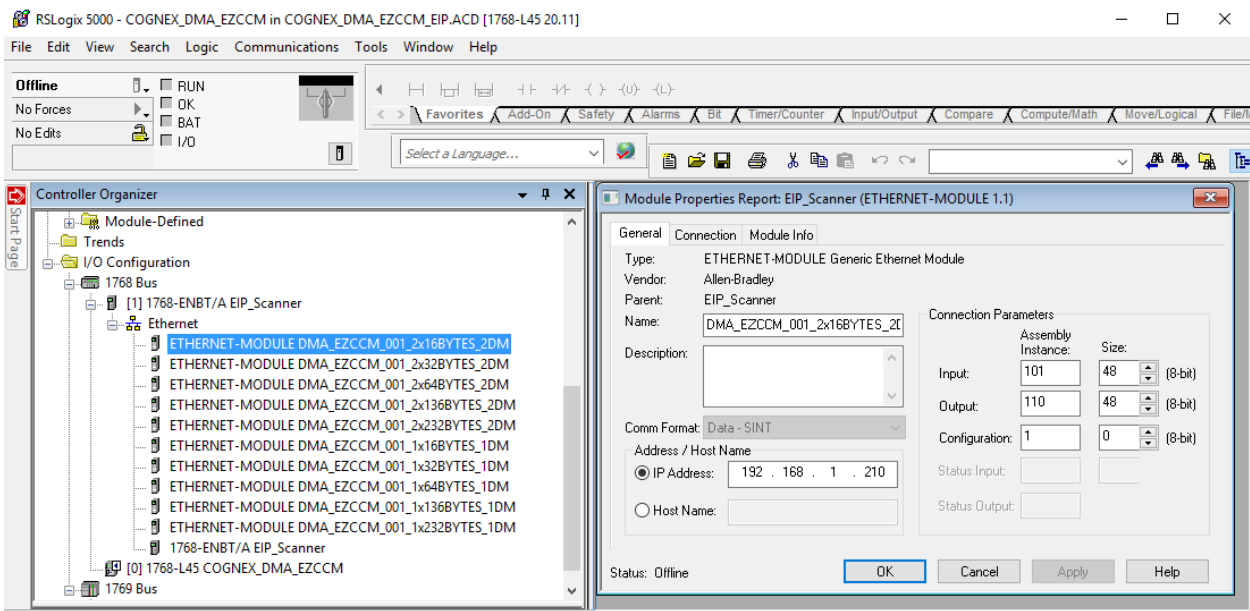

Connecting the device to the PLC:

Drop down the “Ethernet” connections in “I/O Configuration” mapping.

Drag and drop the type of configuration you need into your project.

## Data blocks

The screenshot shows the RSLogix 5000 interface. On the left is the Controller Organizer tree, and on the right is a table of data blocks. The table has columns for Name, Value, Force Mask, Style, Data Type, and Description.

Name	Value	Force Mask	Style	Data Type	Description
Basecode				STRING	
DMA_EZCCM_001_1x16BYTES_IDM.C				AB.ETHERNET_MODULE.C.0	
DMA_EZCCM_001_1x16BYTES_IDM.I				AB.ETHERNET_MODULE_SINT_24Byt...	
DMA_EZCCM_001_1x16BYTES_IDM.I.Data			Decimal	SINT[24]	
DMA_EZCCM_001_1x16BYTES_IDM.O				AB.ETHERNET_MODULE_SINT_24Byt...	
DMA_EZCCM_001_1x16BYTES_IDM.O.Data			Decimal	SINT[24]	
DMA_EZCCM_001_1x32BYTES_IDM.C				AB.ETHERNET_MODULE.C.0	
DMA_EZCCM_001_1x32BYTES_IDM.I				AB.ETHERNET_MODULE_SINT_40Byt...	
DMA_EZCCM_001_1x32BYTES_IDM.I.Data			Decimal	SINT[40]	
DMA_EZCCM_001_1x32BYTES_IDM.O				AB.ETHERNET_MODULE_SINT_40Byt...	
DMA_EZCCM_001_1x32BYTES_IDM.O.Data			Decimal	SINT[40]	
DMA_EZCCM_001_1x64BYTES_IDM.C				AB.ETHERNET_MODULE.C.0	
DMA_EZCCM_001_1x64BYTES_IDM.I				AB.ETHERNET_MODULE_SINT_72Byt...	
DMA_EZCCM_001_1x64BYTES_IDM.I.Data			Decimal	SINT[72]	
DMA_EZCCM_001_1x64BYTES_IDM.O				AB.ETHERNET_MODULE_SINT_72Byt...	
DMA_EZCCM_001_1x64BYTES_IDM.O.Data			Decimal	SINT[72]	
DMA_EZCCM_001_1x128BYTES_IDM.C				AB.ETHERNET_MODULE.C.0	
DMA_EZCCM_001_1x128BYTES_IDM.I				AB.ETHERNET_MODULE_SINT_144Byt...	
DMA_EZCCM_001_1x128BYTES_IDM.I.Data			Decimal	SINT[144]	
DMA_EZCCM_001_1x128BYTES_IDM.O				AB.ETHERNET_MODULE_SINT_144Byt...	
DMA_EZCCM_001_1x128BYTES_IDM.O.Data			Decimal	SINT[144]	
DMA_EZCCM_001_1x256BYTES_IDM.C				AB.ETHERNET_MODULE.C.0	
DMA_EZCCM_001_1x256BYTES_IDM.I				AB.ETHERNET_MODULE_SINT_240Byt...	
DMA_EZCCM_001_1x256BYTES_IDM.I.Data			Decimal	SINT[240]	
DMA_EZCCM_001_1x256BYTES_IDM.O				AB.ETHERNET_MODULE_SINT_240Byt...	
DMA_EZCCM_001_1x256BYTES_IDM.O.Data			Decimal	SINT[240]	
DMA_EZCCM_001_2x16BYTES_IDM.C				AB.ETHERNET_MODULE.C.0	
DMA_EZCCM_001_2x16BYTES_IDM.I				AB.ETHERNET_MODULE_SINT_48Byt...	
DMA_EZCCM_001_2x16BYTES_IDM.I.Data			Decimal	SINT[48]	
DMA_EZCCM_001_2x16BYTES_IDM.O				AB.ETHERNET_MODULE_SINT_48Byt...	
DMA_EZCCM_001_2x16BYTES_IDM.O.Data			Decimal	SINT[48]	
DMA_EZCCM_001_2x32BYTES_IDM.C				AB.ETHERNET_MODULE.C.0	
DMA_EZCCM_001_2x32BYTES_IDM.I				AB.ETHERNET_MODULE_SINT_80Byt...	
DMA_EZCCM_001_2x32BYTES_IDM.I.Data			Decimal	SINT[80]	
DMA_EZCCM_001_2x32BYTES_IDM.O				AB.ETHERNET_MODULE_SINT_80Byt...	
DMA_EZCCM_001_2x32BYTES_IDM.O.Data			Decimal	SINT[80]	
DMA_EZCCM_001_2x64BYTES_IDM.C				AB.ETHERNET_MODULE.C.0	
DMA_EZCCM_001_2x64BYTES_IDM.I				AB.ETHERNET_MODULE_SINT_144Byt...	
DMA_EZCCM_001_2x64BYTES_IDM.I.Data			Decimal	SINT[144]	
DMA_EZCCM_001_2x64BYTES_IDM.O				AB.ETHERNET_MODULE_SINT_144Byt...	
DMA_EZCCM_001_2x64BYTES_IDM.O.Data			Decimal	SINT[144]	
DMA_EZCCM_001_2x128BYTES_IDM.C				AB.ETHERNET_MODULE.C.0	
DMA_EZCCM_001_2x128BYTES_IDM.I				AB.ETHERNET_MODULE_SINT_288Byt...	
DMA_EZCCM_001_2x128BYTES_IDM.I.Data			Decimal	SINT[288]	
DMA_EZCCM_001_2x128BYTES_IDM.O				AB.ETHERNET_MODULE_SINT_288Byt...	
DMA_EZCCM_001_2x128BYTES_IDM.O.Data			Decimal	SINT[288]	

## Data memory Input

Name	Value	Force Mask	Style	Data Type	Description
DMA_EZCCM_001_1x16BYTES_IDM.I				AB.ETHERNET_MODULE_SINT_24Byt...	
DMA_EZCCM_001_1x16BYTES_IDM.I.Data			Decimal	SINT[24]	
DMA_EZCCM_001_1x16BYTES_IDM.I.Data[0]	0		Decimal	SINT	DM1 Trigger Status
DMA_EZCCM_001_1x16BYTES_IDM.I.Data[1]	0		Decimal	SINT	DM1 Result Status
DMA_EZCCM_001_1x16BYTES_IDM.I.Data[2]	0		Decimal	SINT	DM1 Soft Event Status
DMA_EZCCM_001_1x16BYTES_IDM.I.Data[3]	0		Decimal	SINT	DM1 Result Code (0 - Trigger, 1 - Soft Event Running, 2 - Soft Event Complete)
DMA_EZCCM_001_1x16BYTES_IDM.I.Data[4]	0		Decimal	SINT	DM1 Trigger ID (ID of the next trigger)
DMA_EZCCM_001_1x16BYTES_IDM.I.Data[5]	0		Decimal	SINT	DM1 Result ID
DMA_EZCCM_001_1x16BYTES_IDM.I.Data[6]	0		Decimal	SINT	DM1 Result Length
DMA_EZCCM_001_1x16BYTES_IDM.I.Data[7]	0		Decimal	SINT	DM1 Data Block Size ACK : 0 - 16 Bytes 1 - 32 Bytes 2 - 64 bytes 3 - 136 bytes 4 - 232 bytes
DMA_EZCCM_001_1x16BYTES_IDM.I.Data[8]	0		Decimal	SINT	DM1 Result Data (bytes 8..23)
DMA_EZCCM_001_1x16BYTES_IDM.I.Data[9]	0		Decimal	SINT	
DMA_EZCCM_001_1x16BYTES_IDM.I.Data[10]	0		Decimal	SINT	
DMA_EZCCM_001_1x16BYTES_IDM.I.Data[11]	0		Decimal	SINT	
DMA_EZCCM_001_1x16BYTES_IDM.I.Data[12]	0		Decimal	SINT	
DMA_EZCCM_001_1x16BYTES_IDM.I.Data[13]	0		Decimal	SINT	
DMA_EZCCM_001_1x16BYTES_IDM.I.Data[14]	0		Decimal	SINT	
DMA_EZCCM_001_1x16BYTES_IDM.I.Data[15]	0		Decimal	SINT	
DMA_EZCCM_001_1x16BYTES_IDM.I.Data[16]	0		Decimal	SINT	
DMA_EZCCM_001_1x16BYTES_IDM.I.Data[17]	0		Decimal	SINT	
DMA_EZCCM_001_1x16BYTES_IDM.I.Data[18]	0		Decimal	SINT	
DMA_EZCCM_001_1x16BYTES_IDM.I.Data[19]	0		Decimal	SINT	
DMA_EZCCM_001_1x16BYTES_IDM.I.Data[20]	0		Decimal	SINT	
DMA_EZCCM_001_1x16BYTES_IDM.I.Data[21]	0		Decimal	SINT	
DMA_EZCCM_001_1x16BYTES_IDM.I.Data[22]	0		Decimal	SINT	
DMA_EZCCM_001_1x16BYTES_IDM.I.Data[23]	0		Decimal	SINT	

Name	Value	Force Mask	Style	Data Type	Description
DMA_EZCCM_001_1x16BYTES_IDM.I	{...}	{...}		AB:ETHERNET_MODULE_SINT_248yt...	
DMA_EZCCM_001_1x16BYTES_IDM.I.Data	{...}	{...}	Decimal	SINT[24]	
DMA_EZCCM_001_1x16BYTES_IDM.I.Data[0]	0		Decimal	SINT	DM1 Trigger Status
DMA_EZCCM_001_1x16BYTES_IDM.I.Data[0]0	0		Decimal	BOOL	DM1 Trigger Ready
DMA_EZCCM_001_1x16BYTES_IDM.I.Data[0]1	0		Decimal	BOOL	DM1 Trigger ACK
DMA_EZCCM_001_1x16BYTES_IDM.I.Data[0]2	0		Decimal	BOOL	DM1 Acquiring
DMA_EZCCM_001_1x16BYTES_IDM.I.Data[0]3	0		Decimal	BOOL	DM1 Missed Trigger
DMA_EZCCM_001_1x16BYTES_IDM.I.Data[0]4	0		Decimal	BOOL	DM1 Current Mode (0- Setup Tool Mode, 1- Run Mode)
DMA_EZCCM_001_1x16BYTES_IDM.I.Data[0]5	0		Decimal	BOOL	DM1 Serial Error (0- no error or in configuration mode, 1 - No Reader connected)
DMA_EZCCM_001_1x16BYTES_IDM.I.Data[0]6	0		Decimal	BOOL	DM1 Trigger IN1-Pin4 Current State
DMA_EZCCM_001_1x16BYTES_IDM.I.Data[0]7	0		Decimal	BOOL	DM1 Trigger IN2-Pin2 Current State
DMA_EZCCM_001_1x16BYTES_IDM.I.Data[1]	0		Decimal	SINT	DM1 Result Status
DMA_EZCCM_001_1x16BYTES_IDM.I.Data[1]0	0		Decimal	BOOL	DM1 Results Available
DMA_EZCCM_001_1x16BYTES_IDM.I.Data[1]1	0		Decimal	BOOL	DM1 Result Ack Error
DMA_EZCCM_001_1x16BYTES_IDM.I.Data[1]2	0		Decimal	BOOL	DM1 Result Data Buffer Overrun
DMA_EZCCM_001_1x16BYTES_IDM.I.Data[1]3	0		Decimal	BOOL	DM1 Result Status
DMA_EZCCM_001_1x16BYTES_IDM.I.Data[1]4	0		Decimal	BOOL	DM1 Result Status
DMA_EZCCM_001_1x16BYTES_IDM.I.Data[1]5	0		Decimal	BOOL	DM1 Result Status
DMA_EZCCM_001_1x16BYTES_IDM.I.Data[1]6	0		Decimal	BOOL	DM1 Result Status
DMA_EZCCM_001_1x16BYTES_IDM.I.Data[1]7	0		Decimal	BOOL	DM1 General Fault
DMA_EZCCM_001_1x16BYTES_IDM.I.Data[2]	0		Decimal	SINT	DM1 Soft Event Status
DMA_EZCCM_001_1x16BYTES_IDM.I.Data[2]0	0		Decimal	BOOL	DM1 Soft Event Error Code Bit 0
DMA_EZCCM_001_1x16BYTES_IDM.I.Data[2]1	0		Decimal	BOOL	DM1 Soft Event Error Code Bit 1
DMA_EZCCM_001_1x16BYTES_IDM.I.Data[2]2	0		Decimal	BOOL	DM1 Soft Event Error Code Bit 2
DMA_EZCCM_001_1x16BYTES_IDM.I.Data[2]3	0		Decimal	BOOL	DM1 Soft Event Error Code Bit 3
DMA_EZCCM_001_1x16BYTES_IDM.I.Data[2]4	0		Decimal	BOOL	DM1 Soft Event Error Code Bit 4
DMA_EZCCM_001_1x16BYTES_IDM.I.Data[2]5	0		Decimal	BOOL	DM1 Soft Event Error Code Bit 5
DMA_EZCCM_001_1x16BYTES_IDM.I.Data[2]6	0		Decimal	BOOL	DM1 Soft Event Error Code Bit 6
DMA_EZCCM_001_1x16BYTES_IDM.I.Data[2]7	0		Decimal	BOOL	DM1 Command Completed or Timed out
DMA_EZCCM_001_1x16BYTES_IDM.I.Data[3]	0		Decimal	SINT	DM1 Result Code (0 - Trigger, 1 - Soft Event Running, 2 - Soft Event Complete)
DMA_EZCCM_001_1x16BYTES_IDM.I.Data[4]	0		Decimal	SINT	DM1 Trigger ID (ID of the next trigger)
DMA_EZCCM_001_1x16BYTES_IDM.I.Data[5]	0		Decimal	SINT	DM1 Result ID
DMA_EZCCM_001_1x16BYTES_IDM.I.Data[6]	0		Decimal	SINT	DM1 Result Length
DMA_EZCCM_001_1x16BYTES_IDM.I.Data[7]	0		Decimal	SINT	DM1 Data Block Size ACK : 0 - 16 Bytes 1 - 32 Bytes 2 - 64 bytes 3 - 136 bytes 4 - 232 bytes
DMA_EZCCM_001_1x16BYTES_IDM.I.Data[8]	0		Decimal	SINT	DM1 Result Data (bytes 8..23)
DMA_EZCCM_001_1x16BYTES_IDM.I.Data[9]	0		Decimal	SINT	
DMA_EZCCM_001_1x16BYTES_IDM.I.Data[10]	0		Decimal	SINT	
DMA_EZCCM_001_1x16BYTES_IDM.I.Data[11]	0		Decimal	SINT	
DMA_EZCCM_001_1x16BYTES_IDM.I.Data[12]	0		Decimal	SINT	
DMA_EZCCM_001_1x16BYTES_IDM.I.Data[13]	0		Decimal	SINT	
DMA_EZCCM_001_1x16BYTES_IDM.I.Data[14]	0		Decimal	SINT	
DMA_EZCCM_001_1x16BYTES_IDM.I.Data[15]	0		Decimal	SINT	

### Data memory Output

Name	Value	Force Mask	Style	Data Type	Description
DMA_EZCCM_001_1x16BYTES_IDM.I	{...}	{...}		AB:ETHERNET_MODULE_SINT_248yt...	
DMA_EZCCM_001_1x16BYTES_IDM.I.Data	{...}	{...}	Decimal	SINT[24]	
DMA_EZCCM_001_1x16BYTES_IDM.O	{...}	{...}		AB:ETHERNET_MODULE_SINT_248yt...	
DMA_EZCCM_001_1x16BYTES_IDM.O.Data	{...}	{...}	Decimal	SINT[24]	
DMA_EZCCM_001_1x16BYTES_IDM.O.Data[0]	0		Decimal	SINT	DM1 Trigger Control
DMA_EZCCM_001_1x16BYTES_IDM.O.Data[1]	0		Decimal	SINT	DM1 Result Control
DMA_EZCCM_001_1x16BYTES_IDM.O.Data[2]	0		Decimal	SINT	DM1 Soft Event Control
DMA_EZCCM_001_1x16BYTES_IDM.O.Data[3]	0		Decimal	SINT	DM1 User Data Option
DMA_EZCCM_001_1x16BYTES_IDM.O.Data[4]	0		Decimal	SINT	--- Reserved
DMA_EZCCM_001_1x16BYTES_IDM.O.Data[5]	0		Decimal	SINT	--- Reserved
DMA_EZCCM_001_1x16BYTES_IDM.O.Data[6]	0		Decimal	SINT	DM1 User Data Length
DMA_EZCCM_001_1x16BYTES_IDM.O.Data[7]	0		Decimal	SINT	DM1 Data Block Size: 0 - 16 Bytes 1 - 32 Bytes 2 - 64 bytes 3 - 136 bytes 4 - 232 bytes
DMA_EZCCM_001_1x16BYTES_IDM.O.Data[8]	0		Decimal	SINT	DM1 User Data (bytes 8..23)
DMA_EZCCM_001_1x16BYTES_IDM.O.Data[9]	0		Decimal	SINT	
DMA_EZCCM_001_1x16BYTES_IDM.O.Data[10]	0		Decimal	SINT	
DMA_EZCCM_001_1x16BYTES_IDM.O.Data[11]	0		Decimal	SINT	
DMA_EZCCM_001_1x16BYTES_IDM.O.Data[12]	0		Decimal	SINT	
DMA_EZCCM_001_1x16BYTES_IDM.O.Data[13]	0		Decimal	SINT	
DMA_EZCCM_001_1x16BYTES_IDM.O.Data[14]	0		Decimal	SINT	
DMA_EZCCM_001_1x16BYTES_IDM.O.Data[15]	0		Decimal	SINT	
DMA_EZCCM_001_1x16BYTES_IDM.O.Data[16]	0		Decimal	SINT	
DMA_EZCCM_001_1x16BYTES_IDM.O.Data[17]	0		Decimal	SINT	
DMA_EZCCM_001_1x16BYTES_IDM.O.Data[18]	0		Decimal	SINT	
DMA_EZCCM_001_1x16BYTES_IDM.O.Data[19]	0		Decimal	SINT	
DMA_EZCCM_001_1x16BYTES_IDM.O.Data[20]	0		Decimal	SINT	
DMA_EZCCM_001_1x16BYTES_IDM.O.Data[21]	0		Decimal	SINT	
DMA_EZCCM_001_1x16BYTES_IDM.O.Data[22]	0		Decimal	SINT	
DMA_EZCCM_001_1x16BYTES_IDM.O.Data[23]	0		Decimal	SINT	

Name	Value	Force Mask	Style	Data Type	Description
- DMA_EZCCM_001_1x16BYTES_1DM	{...}	{...}		AB:ETHERNET_MODULE_SINT_24byt...	
+ DMA_EZCCM_001_1x16BYTES_1DM:Data	{...}	{...}	Decimal	SINT[24]	
- DMA_EZCCM_001_1x16BYTES_1DM:0	{...}	{...}		AB:ETHERNET_MODULE_SINT_24byt...	
- DMA_EZCCM_001_1x16BYTES_1DM:0:Data	{...}	{...}	Decimal	SINT[24]	
- DMA_EZCCM_001_1x16BYTES_1DM:0:Data[0]	0		Decimal	SINT	DM1 Trigger Control
- DMA_EZCCM_001_1x16BYTES_1DM:0:Data[0]:0	0		Decimal	BOOL	DM1 Trigger Enable
- DMA_EZCCM_001_1x16BYTES_1DM:0:Data[0]:1	0		Decimal	BOOL	DM1 Trigger
- DMA_EZCCM_001_1x16BYTES_1DM:0:Data[0]:2	0		Decimal	BOOL	--Reserved
- DMA_EZCCM_001_1x16BYTES_1DM:0:Data[0]:3	0		Decimal	BOOL	--Reserved
- DMA_EZCCM_001_1x16BYTES_1DM:0:Data[0]:4	0		Decimal	BOOL	DM1 Force Run Mode
- DMA_EZCCM_001_1x16BYTES_1DM:0:Data[0]:5	0		Decimal	BOOL	DM1 Trigger Setting (0 - individual Trigger per channel, 1- DM1 triggers both readers)
- DMA_EZCCM_001_1x16BYTES_1DM:0:Data[0]:6	0		Decimal	BOOL	DM1 Trigger Pin
- DMA_EZCCM_001_1x16BYTES_1DM:0:Data[0]:7	0		Decimal	BOOL	DM1 Trigger Edge
- DMA_EZCCM_001_1x16BYTES_1DM:0:Data[1]	0		Decimal	SINT	DM1 Result Control
- DMA_EZCCM_001_1x16BYTES_1DM:0:Data[1]:0	0		Decimal	BOOL	DM1 ResultAck
- DMA_EZCCM_001_1x16BYTES_1DM:0:Data[1]:1	0		Decimal	BOOL	DM1 Result Control
- DMA_EZCCM_001_1x16BYTES_1DM:0:Data[1]:2	0		Decimal	BOOL	DM1 Result Control
- DMA_EZCCM_001_1x16BYTES_1DM:0:Data[1]:3	0		Decimal	BOOL	DM1 Result Control
- DMA_EZCCM_001_1x16BYTES_1DM:0:Data[1]:4	0		Decimal	BOOL	DM1 Result Control
- DMA_EZCCM_001_1x16BYTES_1DM:0:Data[1]:5	0		Decimal	BOOL	DM1 Result Control
- DMA_EZCCM_001_1x16BYTES_1DM:0:Data[1]:6	0		Decimal	BOOL	DM1 Result Control
- DMA_EZCCM_001_1x16BYTES_1DM:0:Data[1]:7	0		Decimal	BOOL	DM1 Result Control
- DMA_EZCCM_001_1x16BYTES_1DM:0:Data[2]	0		Decimal	SINT	DM1 Soft Event Control
- DMA_EZCCM_001_1x16BYTES_1DM:0:Data[2]:0	0		Decimal	BOOL	DM1 Train Code
- DMA_EZCCM_001_1x16BYTES_1DM:0:Data[2]:1	0		Decimal	BOOL	DM1 Train Match String
- DMA_EZCCM_001_1x16BYTES_1DM:0:Data[2]:2	0		Decimal	BOOL	DM1 Train Focus
- DMA_EZCCM_001_1x16BYTES_1DM:0:Data[2]:3	0		Decimal	BOOL	DM1 Train Brightness
- DMA_EZCCM_001_1x16BYTES_1DM:0:Data[2]:4	0		Decimal	BOOL	DM1 Untrain
- DMA_EZCCM_001_1x16BYTES_1DM:0:Data[2]:5	0		Decimal	BOOL	DM1 Set Input String
- DMA_EZCCM_001_1x16BYTES_1DM:0:Data[2]:6	0		Decimal	BOOL	DM1 Execute DMCC
- DMA_EZCCM_001_1x16BYTES_1DM:0:Data[2]:7	0		Decimal	BOOL	DM1 Set Match String
+ DMA_EZCCM_001_1x16BYTES_1DM:0:Data[3]	0		Decimal	SINT	DM1 User Data Option
+ DMA_EZCCM_001_1x16BYTES_1DM:0:Data[3]:4	0		Decimal	SINT	--- Reserved
+ DMA_EZCCM_001_1x16BYTES_1DM:0:Data[3]:5	0		Decimal	SINT	--- Reserved
+ DMA_EZCCM_001_1x16BYTES_1DM:0:Data[3]:6	0		Decimal	SINT	DM1 User Data Length
+ DMA_EZCCM_001_1x16BYTES_1DM:0:Data[3]:7	0		Decimal	SINT	DM1 Data Block Size: 0- 16 Bytes 1- 32 Bytes 2- 64 bytes 3- 136 bytes 4- 232 bytes
+ DMA_EZCCM_001_1x16BYTES_1DM:0:Data[3]:8	0		Decimal	SINT	DM1 User Data (bytes 8..23)
+ DMA_EZCCM_001_1x16BYTES_1DM:0:Data[3]:9	0		Decimal	SINT	
+ DMA_EZCCM_001_1x16BYTES_1DM:0:Data[3]:10	0		Decimal	SINT	
+ DMA_EZCCM_001_1x16BYTES_1DM:0:Data[3]:11	0		Decimal	SINT	
+ DMA_EZCCM_001_1x16BYTES_1DM:0:Data[3]:12	0		Decimal	SINT	
+ DMA_EZCCM_001_1x16BYTES_1DM:0:Data[3]:13	0		Decimal	SINT	

# Troubleshooting

If the device does not function as expected, first check whether ambient interference is present. If there is no ambient interference present, check the connections of the device for faults.

If there are no faults, there is a device malfunction. In this case, decommission the device and replace it with a new device of the same type.

# Maintenance

Ensure that the plug connections and cables are always in good condition.

The devices are maintenance-free. Clean the devices with a dry cloth, if required.

## Firmware Update

The device firmware can be updated via Cognex DataMan Setup Tool and the latest version is included in the installer.

**CAUTION:** Do not reset or interrupt the power supply during firmware update, as faulty firmware update can damage the device."

- Open Cognex DataMan Setup Tool
- Select Maintenance -> Update Firmware
- Select device and the required firmware file.
- Press Upload Firmware

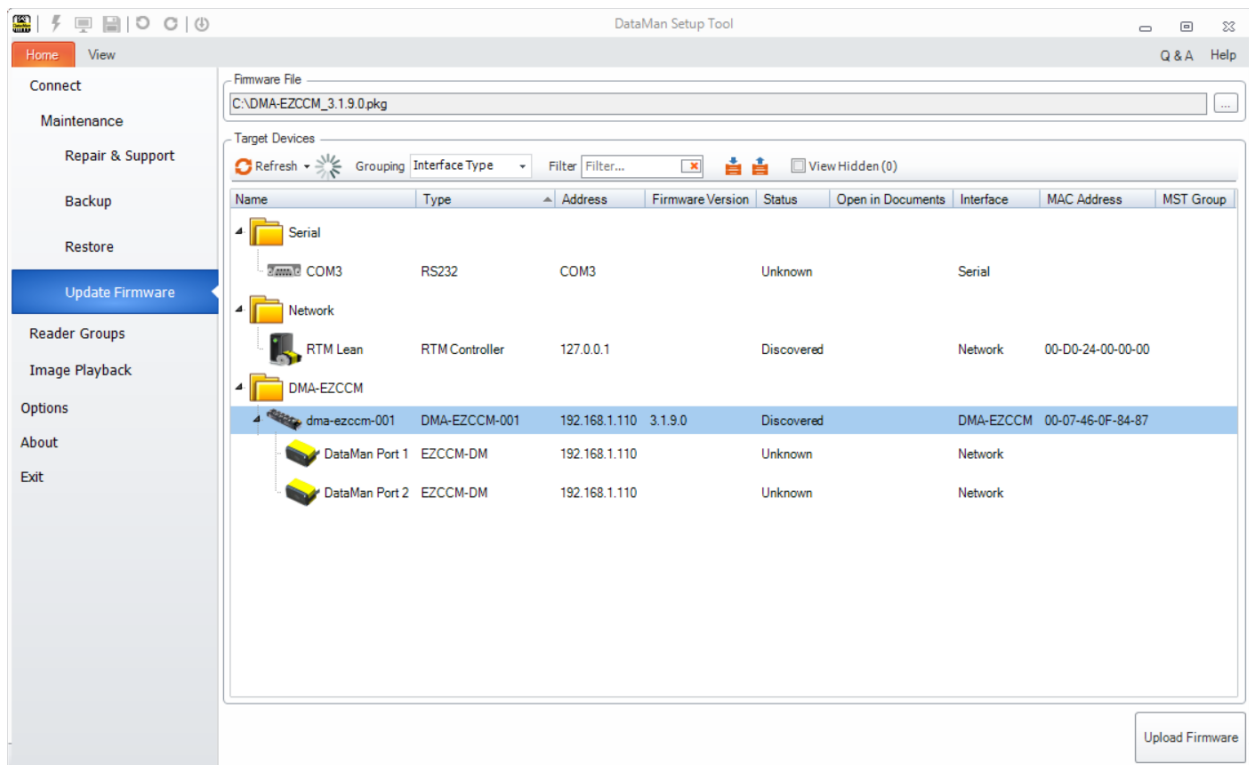

## Repair

The device must not be repaired by the user. The device must be decommissioned if it is faulty. Observe our return acceptance conditions when returning the device to Cognex.

## Disposal

The devices must be disposed of correctly and must not be included in normal house-hold garbage.

# Appendix

Possible Network Structures:

Network Structure Example 1:

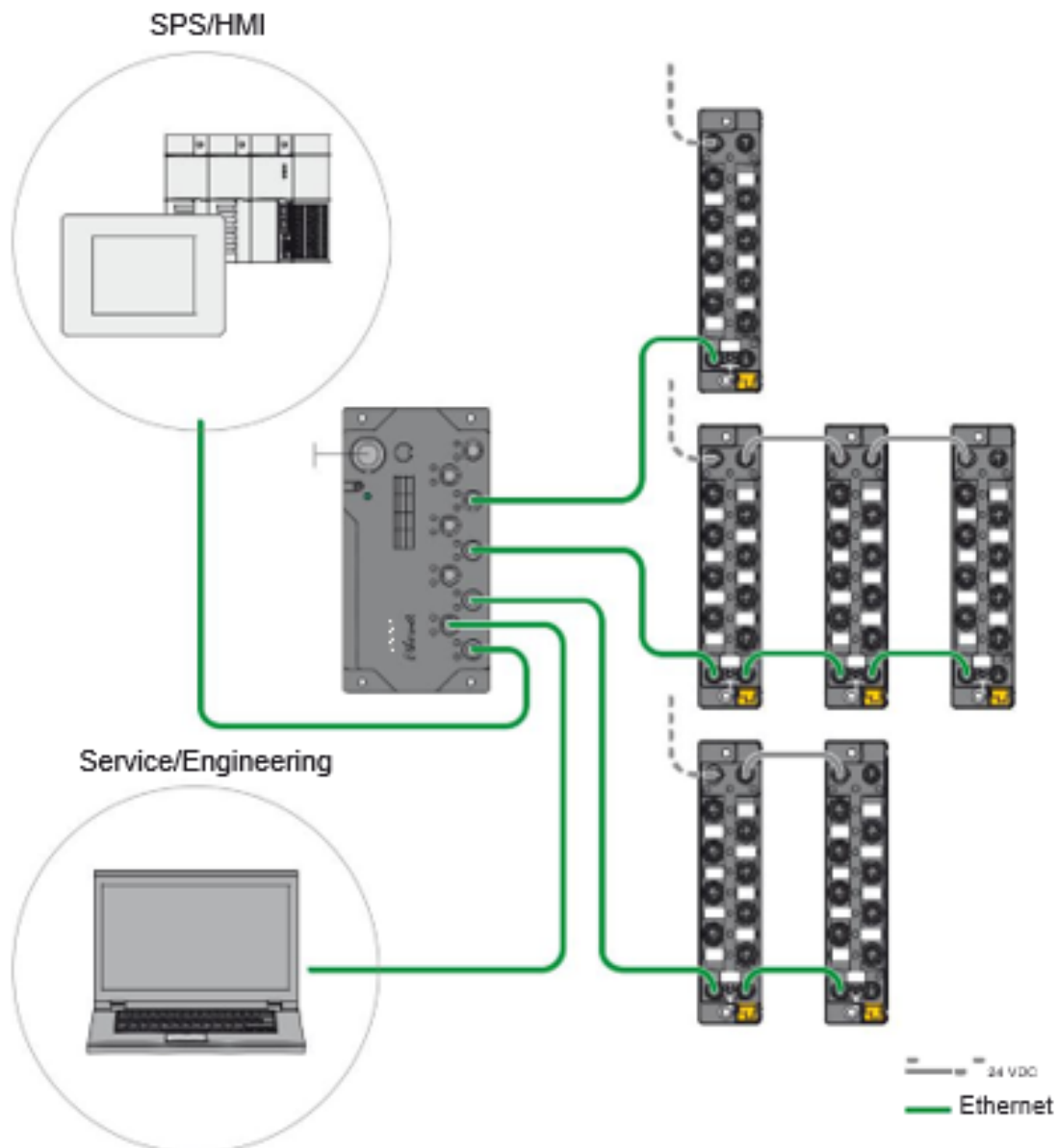

Network Structure Example 2:

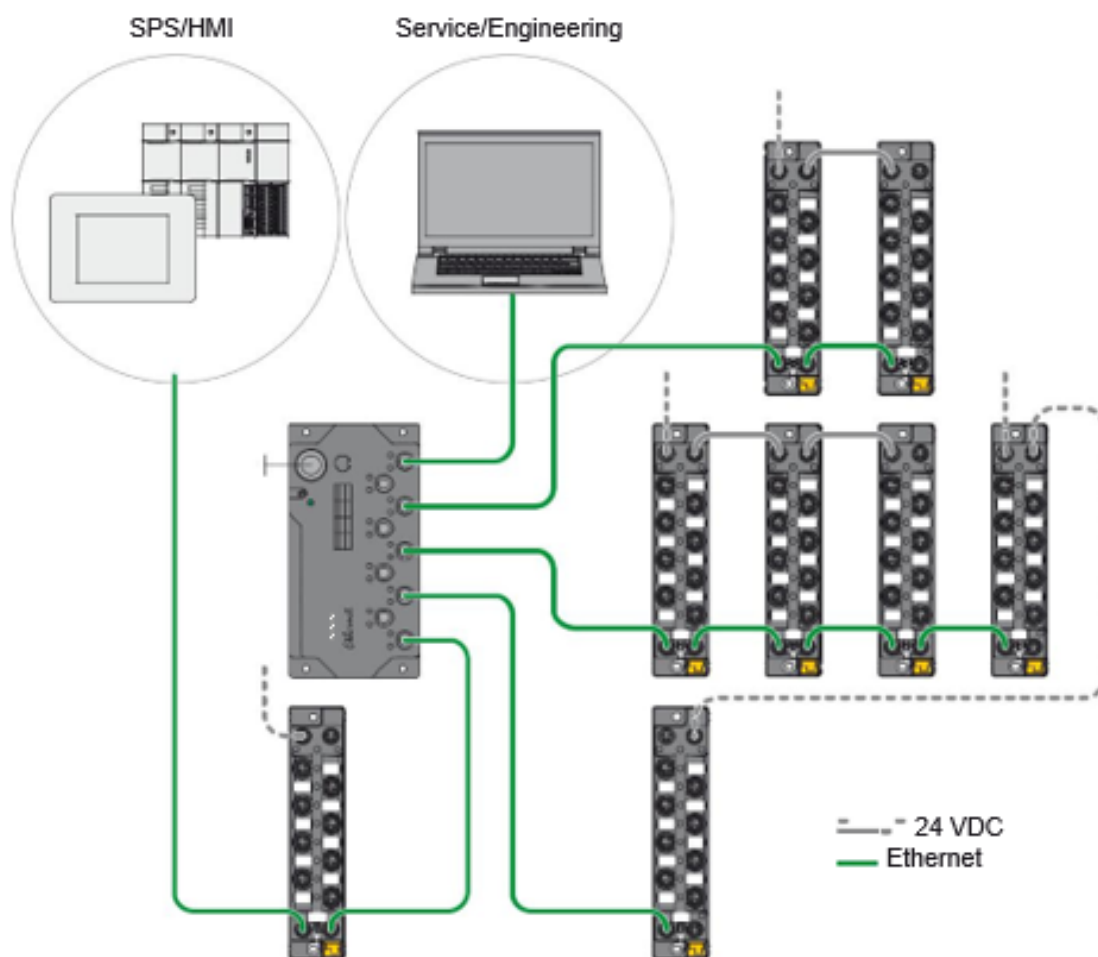

Network Structure Example 3:

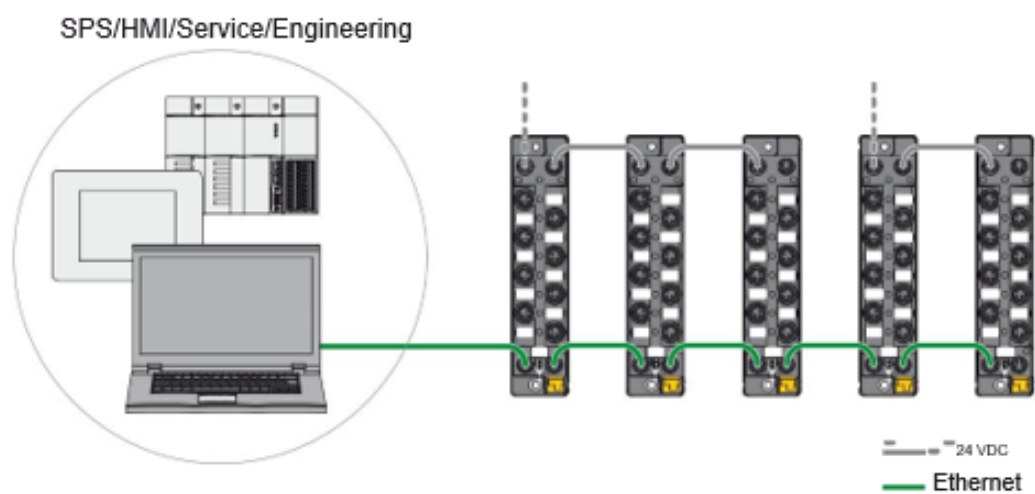

## Daisy Chain – Maximum Number of Connected Modules

Prerequisites:

- Optimized network
- Only DMA-EZCCM-001 modules in the daisy chain, no additional switches, no third-party devices
- Exchange of pure process data, no acyclic data
- Cable length between the DMA-EZCCM-001 modules max. 50 m
- Power chain is not reaching 4A

Cycle time	Maximum number of DMA-EZCCM-001 modules
1 ms	21
2 ms	42

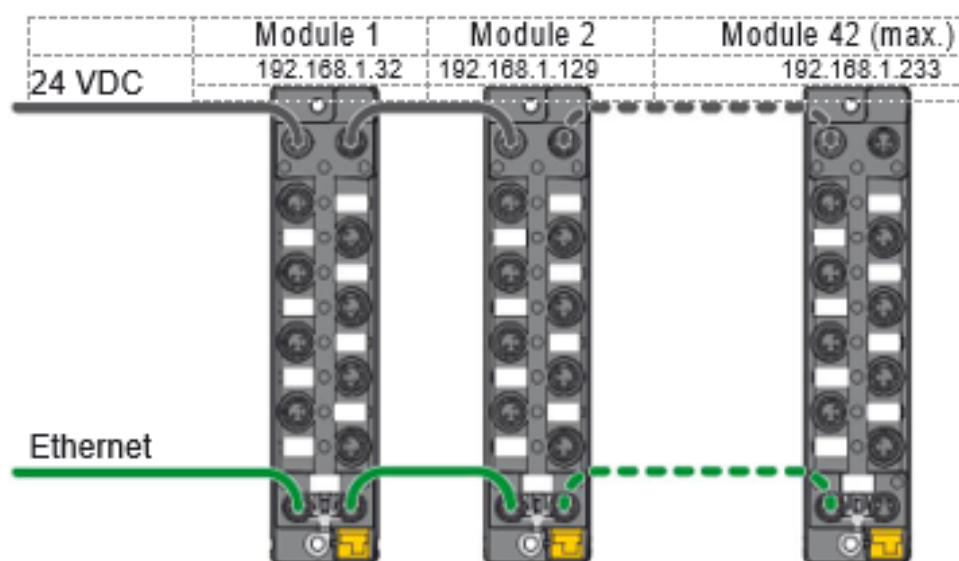
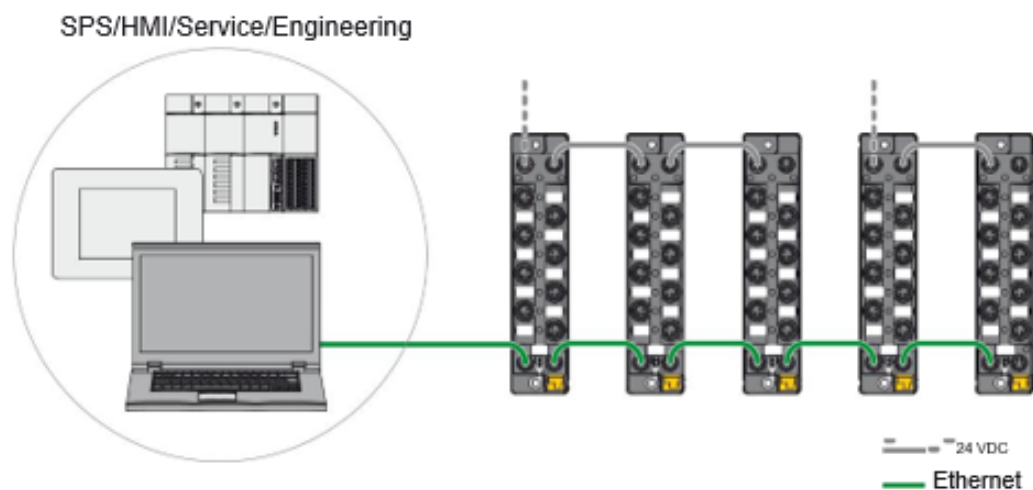

Fig. 83: Daisy Chain

Depending on the amount and type of DataMan Readers connected to DMA-EZCCM-001 the 24VDC chain might be reduced. Ethernet chain can continue as per specifications above.

The figure below shows a concept of multiple 24VDC chains, and maintaining a single Ethernet chain:



To define the maximum power chain length refer to the table below:

DataMan Connection	Max. number of EZCCM in Power Chain
Single DataMan 70 Series per DMA-EZCCM-001	16
Dual DataMan 70 Series per DMA-EZCCM-001	10
Single DataMan 150 / 260 per DMA-EZCCM-001	11
Dual DataMan 150 / 260 per DMA-EZCCM-001	7
Single DataMan 300 / 470 with HPIA per DMA-EZCCM-001	3
Dual DataMan 300 / 470 with HPIA per DMA-EZCCM-001	1

**Note:** DataMan 300 / 470 with HPIL is not supported.

# DMA-EZCCM-001 Specifications

Supply Voltage	24VDC
Operating temperature	-40...+70 °C
Storage temperature	-40...+85 °C
Permissible Range	18-30VDC Total current: maximum 4A per voltage group Total current V1+V2: maximum 5.5 A at 70 °C per module
Operating altitude	max. 5000 m
Protection class	IP65 IP67 IP69K
DataMan Connection	Connectors C0...C1 from V1, short-circuit proof < 55 °C: – 24 V: 1,2 A per port > 55 °C: – 24 V: 0,5 A per port
Sensor/Actuator Supply $V_{AUX2}$	Connectors C2...C3 from V2, short-circuit proof, < 55 °C: 0,14 A per port > 55 °C: 0,05 A per port
Potential isolation	Galvanic isolation of V1 and V2 voltage groups voltage proof up to 500 VDC

System data	
Transmission Ethernet	10 Mbps 100 Mbps
Connection to Ethernet	2 x M8, 4-pin
Protocol detection	automatic
Web server	default: 192.168.1.254
Service interface	Ethernet via P1 or P2

EtherNet/IP™	
Address assignment	according to EtherNet/IP™ standard
Device Level Ring (DLR)	supported
Number of TCP connections	1
Number of CIP connections	1
Assembly Instance	101
Output Assembly Instance	110
Configuration Assembly Instance	1

PROFINET	
Address assignment	DCP
Conformance class	B (RT)
MinCycleTime	1 ms

<b>PROFINET</b>	
Diagnostics	according to PROFINET Alarm Handling
Topology discovery	supported
Media Redundancy Protocol (MRP)	supported
Cable length	max. 30 m

<b>DataMan interface</b>	
Signal type	RS232
Number of channels	2

<b>Operation mode RS232</b>	
Signal low level	-18...-3 VDC
Signal high level	3...18 VDC
Transmission signals	TxD, RxD
Transmission rate	115200 bps
Transmission type	Full duplex
Cable length	5 m at 115200 baud (max. line capacity < 2000 pF)

<b>Digital inputs</b>	
Number of channels	4
Connection technology inputs	M12, 5-pin
Input type	PNP
Type of input diagnostics	channel diagnostics
Switching threshold	EN 61131-2 type 3, PNP
Signal voltage, low level	< 5 V
Signal voltage, high level	> 11V
Low-level signal current	< 1.5 mA
High-level signal current	> 2 mA
Input delay	0.05 ms
Electrical isolation	galvanic isolation to P1/P2, voltage proof up to 500 VDC

# Precautions

To reduce the risk of injury or equipment damage, observe the following precautions when you install the Cognex product:

- Route cables and wires away from high-current wiring or high-voltage power sources to reduce the risk of damage or malfunction from the following causes: over-voltage, line noise, electrostatic discharge (ESD), power surges, or other irregularities in the power supply.
- Changes or modifications not expressly approved by the party responsible for regulatory compliance could void the user's authority to operate the equipment.
- Ensure that the cable bend radius begins at least six inches from the connector. Cable shielding can be degraded or cables can be damaged or wear out faster if a service loop or bend radius is tighter than 10X the cable diameter.
- This device should be used in accordance with the instructions in this manual.
- All specifications are for reference purposes only and can change without notice.
- The device may only be assembled, installed, operated and maintained by professionally trained personnel.
- The device may only be used in accordance with applicable national and international regulations, standards and laws.
- The device only meets the EMC requirements for industrial areas and is not suitable for use in residential areas.

# Regulations/Conformity

## Product Identification

These instructions apply for the following compact serial interface modules:

- DMA-EZCCM-001

## Scope of Delivery

The delivery scope contains:

- DMA-EZCCM-001

## Legal Requirements

The device falls under the following EU directives:

- 2014/30/EU (electromagnetic compatibility)
- 2011/65/EC (RoHS II Directive)

Safety and Regulatory	
Manufacturer	Hans Turck GmbH & Co. KG Witzlebenstraße 7 45472 Muelheim an der Ruhr Germany

## Safety

The product is designed according to state-of-the-art technology. However, residual risks still exist. Observe the following warnings and safety notices to prevent damage to persons and property. Cognex accepts no liability for damage caused by failure to observe these warning and safety notices.

## Intended Use

The devices are only intended for use in industrial applications.

The DMA-EZCCM-001 devices provide a multiprotocol Ethernet interface for EtherNet/IP™ and PROFINET. The DataMan interfaces are used for connecting devices Cognex DataMan Barcode Readers. Additionally, the module provides 4 universal digital input channels.

The devices may only be used as described in this manual. Any other use is not in accordance with the intended use. Cognex accepts no liability for any resulting damage.

## General Safety Instructions

- The device may only be assembled, installed, operated and maintained by professionally trained personnel.
- The device may only be used in accordance with applicable national and international regulations, standards and laws.
- The device only meets the EMC requirements for industrial areas and is not suitable for use in residential areas.

