

DataMan[®] Fixed-Mount Readers Reference Manual

2025 September 26

Revision: 25.3.2.2

Legal Notices

The software described in this document is furnished under license, and may be used or copied only in accordance with the terms of such license and with the inclusion of the copyright notice shown on this page. Neither the software, this document, nor any copies thereof may be provided to, or otherwise made available to, anyone other than the licensee. Title to, and ownership of, this software remains with Cognex Corporation or its licensor. Cognex Corporation assumes no responsibility for the use or reliability of its software on equipment that is not supplied by Cognex Corporation. Cognex Corporation makes no warranties, either express or implied, regarding the described software, its merchantability, non-infringement or its fitness for any particular purpose.

The information in this document is subject to change without notice and should not be construed as a commitment by Cognex Corporation. Cognex Corporation is not responsible for any errors that may be present in either this document or the associated software.

Companies, names, and data used in examples herein are fictitious unless otherwise noted. No part of this document may be reproduced or transmitted in any form or by any means, electronic or mechanical, for any purpose, nor transferred to any other media or language without the written permission of Cognex Corporation.

Copyright © 2025. Cognex Corporation. All Rights Reserved.

Portions of the hardware and software provided by Cognex may be covered by one or more U.S. and foreign patents, as well as pending U.S. and foreign patents listed on the Cognex web site at: cognex.com/patents.

The following are registered trademarks of Cognex Corporation:

Cognex, 2DMAX, Advantage, AlignPlus, Assemblyplus, Check it with Checker, Checker, Cognex Vision for Industry, Cognex VSOC, CVL, DataMan, DisplayInspect, DVT, EasyBuilder, Hotbars, IDMax, In-Sight, Laser Killer, MVS-8000, OmniView, PatFind, PatFlex, PatInspect, PatMax, PatQuick, SensorView, SmartView, SmartAdvisor, SmartLearn, UltraLight, Vision Solutions, VisionPro, VisionView

The following are trademarks of Cognex Corporation:

The Cognex logo, 1DMax, 3D-Locate, 3DMax, BGAll, CheckPoint, Cognex VSoC, CVC-1000, FFD, iLearn, In-Sight (design insignia with cross-hairs), In-Sight 2000, InspectEdge, Inspection Designer, MVS, NotchMax, OCRMax, PatMax RedLine, ProofRead, SmartSync, ProfilePlus, SmartDisplay, SmartSystem, SMD4, VisiFlex, Xpand

Portions copyright © Microsoft Corporation. All rights reserved.

Portions copyright © MadCap Software, Inc. All rights reserved.

Other product and company trademarks identified herein are the trademarks of their respective owners.

Table of Contents

Legal Notices	2
Table of Contents	3
About This Manual	7
Symbols	7
Safety Information	8
Warnings And Notices	8
Mechanical Information	9
DataMan 50 Reader Dimensions	9
DataMan 60 Reader Dimensions	10
DataMan 70 Series Reader Dimensions	11
DataMan 150 Reader Dimensions	12
DataMan 260 Reader Dimensions	13
DataMan 280 Reader Dimensions	14
DataMan 300 Series Reader Dimensions	17
DataMan 360 Series Reader Dimensions	19
DataMan 370 Series Reader Dimensions	20
DataMan 370 Series Reader with High Power Integrated Light (HPIL)	20
DataMan 370 Series Reader with High Power Illumination Accessory (HPIA)	21
DataMan 370 Series Reader with High Power Integrated Torch (HPIT)	21
DataMan 470 Series Reader Dimensions	22
DataMan 470 Reader with High Power Integrated Light (HPIL)	22
DataMan 470 Reader with High Power Illumination Accessory (HPIA)	22
DataMan 470 Reader with High Power Integrated Torch (HPIT)	23
DataMan 503 Reader Dimensions	24
Service Procedures	25
DataMan 50 Service Procedures	25
DataMan 60 Service Procedures	27
DataMan 70 Service Procedures	28
DataMan 150 and 260 Series Service Procedures	30
DataMan 280 Installing and Changing Lenses	39
DataMan 300 and 360 Series Service Procedures	52
DataMan 370 and 470 Series Service Procedures	58
DataMan 503 Service Procedures	71
Maintenance	72
Replacing the SD Card	72
Mounting Requirements	74
Mounting the DataMan 70 Reader	74
Mounting the DataMan 150 and 260 Reader	75
Mounting the DataMan 280 Reader	79
Mounting the DataMan 370 and 470 Reader	79
Grounding	82
Thermal and Environmental Requirements	83
DataMan 50, 150, 260, 300, 360, and 503 IP Rating	83
DataMan 60 and 70 IP Rating	83

DataMan 280, 370 and 470 IP Rating	83
Electrical Information	85
DataMan 50 and 60 Discrete I/O Connector	85
DataMan 50 and 60 USB & Flying Leads I/O Cable	85
DataMan 50 and 60 RS-232 & Flying Leads I/O Cable	86
DataMan 50 and 60 Flying Leads Cable	86
DataMan 50 and 60 Digital Input Lines	87
DataMan 50 and 60 External Wiring Examples: Digital Input Lines	88
DataMan 50 and 60 Digital Output Lines	89
DataMan 50 and 60 External Wiring Examples: Digital Output Lines	90
DataMan 70 15 Pin Adapter Cable	91
DataMan 70 9 Pin Adapter Cable	92
DataMan 70 Serial IO Adapter (DMA-SERIALREST-ST)	93
DataMan 150 USB Cable	93
DataMan 70 and 150 Discrete I/O Connector	95
DataMan 70 and 150 RS-232 Cable	95
DataMan 150 Flying Leads Cable	96
DataMan 150 USB Connections	96
DataMan 150 RS-232 Connections	97
DataMan 150 Wiring the Basic I/O Module	97
Output Wiring Example	98
Input Wiring Example	99
DataMan 150 Digital Input Wiring Diagrams	99
Current Sink Configuration	99
Current Source Configuration	99
PNP Configuration	100
NPN Configuration	100
Dataman 150 Digital Output Wiring Diagrams	100
Sinking Outputs, Sourcing Inputs	101
Sinking Outputs, Sinking Inputs	101
Electrical Information	102
DataMan 260 Discrete I/O Connector	102
DataMan 260 Ethernet Cable	103
DataMan 280 Ethernet Cable	104
DataMan 150 and 260 Acquisition Triggering	105
DataMan 280 Acquisition Triggering	106
DataMan 260 High-Speed Output Lines	106
DataMan 260 High-Speed Output Wiring	107
DataMan 280 High-Speed Outputs	108
High Speed Output Wiring	109
DataMan 280 Discrete I/O Connector	110
CCBL-05-01 and CCB-PWRIO-05	110
CCB-M12x12Fy-xx	111
Dataman 300 5m RS-232 Connection Cable (CCB-M12XDB9Y-05)	111
DataMan 300, 360, 370, and 470 Series Readers Discrete I/O Connector	112
5m Breakout Cable (CCBL-05-01)	112
5m Breakout Cable (CCB-M12x12Fy-xx)	113

15m Breakout Cable (CCB-PWRIO-XX)	114
DataMan 300, 360, 370, and 470 Series Readers External Light Control	115
DataMan 300, 360, 370, and 470 Series Readers Power Requirements	115
DataMan 300, 360, 370, and 470 Series and DataMan 503 Readers Acquisition Triggering	115
DataMan 300, 360, 370, and 470 Series, and DataMan 503 Readers High-Speed Output Lines	116
DataMan 300, 360, 370, and 470 Series Readers High-Speed Output Wiring	118
DataMan 300 and 503 Ethernet M12 to RJ45 Cable (CCB-84901-y00x-xx)	119
DataMan 503 Discrete I/O Connector	120
5 m Breakout Cable (CCBL-05-01)	120
DataMan 503 RS-232 Serial Connector	120
DataMan 503 External Light Control	121
DataMan 503 High-Speed Output Wiring	121
DataMan 503 Power Requirements	122
Connecting the Encoder to a DataMan	123
Optics and Lighting	124
DataMan 50 and 60 Reading Distances and Field of View	124
DataMan 70, 150 and 260 Reading Distances and Field of View	126
DataMan 280 Reading Distances and Field of View	130
DataMan 300 and 360 Series Readers Reading Distances and Field of View	133
Scan Map for DataMan 300 and 360 Series Readers Using a 10.3 mm Lens	133
Scan Map for DataMan 300 and 360 Series Readers Using a 16 mm Lens	134
Scan Map for DataMan 300 and 360 Series Readers Using a 19 mm Lens	135
Scan Map for DataMan 300 and 360 Series Readers Using a 24 mm Lens with Liquid Lens	136
Scan Map for DataMan 300 and 360 Series Readers Using a 25 mm Lens	138
DataMan 370 Series Readers Reading Distances and Field of View	139
Reading Distance and Field of View for DataMan 370 Series Readers with a 10 mm High-Speed Liquid Lens	139
Reading Distance and Field of View for DataMan 370 Series Readers with a 16 mm High-Speed Liquid Lens	140
Reading Distance and Field of View for DataMan 370 Series Readers with a 24 mm High-Speed Liquid Lens	141
DataMan 470 Series Readers Reading Distances and Field of View	142
Reading Distance and Field of View for DataMan 470 Series Readers with a 10 mm High-Speed Liquid Lens	142
Reading Distance and Field of View for DataMan 470 Series Readers with a 16 mm High-Speed Liquid Lens	143
Reading Distance and Field of View for DataMan 470 Series Readers with a 24 mm High-Speed Liquid Lens	144
DataMan 503 Readers Reading Distances and Field of View	146
Scan Map for DataMan 503 Series Readers Using a 16 mm Lens Module	146
Scan Map for DataMan 503 Series Readers Using a 25 mm Lens Module	147
Scan Map for DataMan 503 Series Readers Using a 35 mm Lens Module	148
CS-Mount Lens Characteristics	149
DataMan 503 CS-Mount Lens Characteristics	149
Internal Lighting	150
DataMan 50 and 60 Internal Lighting	150
DataMan 70, 150 and 260 Internal Lighting	150
DataMan 300, 360, 370, and 470 Series Readers Internal Lighting	150

External Lighting	152
DataMan 50 and 60 External Lighting	152
DataMan 50 and 60 Illumination Strobe Output	152
DataMan 50 and 60 External Load Strobe Output	154
DataMan 300, 360, 370, and 470 Series Readers External Lighting	154
DataMan 50, 60, 300, 360, 370, and 470 External Lighting Duration	157
DataMan 503 External Lighting Duration	157
Operations Guide	158
Trigger Modes	158
Self-Trigger	158
Manual	158
Burst	158
Continuous	158
Single	158
Presentation	158
Package Detection Support	159
Test Mode	159
Code Training	160
Automatic Code Training for DPM Symbols	160
Image Buffering and Image Recording	160
Retrieving Buffered Images	161
DataMan Multi-Reader Sync Configuration	161
Primary Reader	162
Secondary Readers	162
Data Formatting	162
Limitations	162
Synchronized Acquisition	162
Using C/CS-Mount Lenses	165
Aperture Setting	165
Selecting Optimum Focus	165
Optimizing Performance	165
Read Interval and Timeout Configuration	165
Optimizing Burst Trigger Parameters	165
Reducing DataMan Processing Requirements	166
Avoiding Reflections and Glare	166
Application Guide	167
Understanding Your Application Envelope	167
Tote Scanning	168
Side Scanning	169
Side Scanning (Large Field)	170
Print Verification (Carton Coding and Print & Apply)	170
Manual Presentation Scanning	172
Precautions	173

About This Manual

The *DataMan Fixed-Mount Readers Reference* provides detailed information on the configuration and operation of DataMan fixed-mount readers. It includes the following sections:

- [Safety Information](#)
- [Mechanical Information](#)
- [Electrical Information](#)
- [Optics and Lighting](#)
- [Operation](#)
- [Application Guide](#)

Symbols

The following symbols indicate safety precautions and supplemental information:

 **WARNING:** This symbol indicates a hazard that could cause death, serious personal injury or electrical shock.

 **CAUTION:** This symbol indicates a hazard that could result in property damage.

 **Note:** This symbol indicates additional information about a subject.

 **Tip:** This symbol indicates suggestions and shortcuts that might not otherwise be apparent.

Safety Information

The DataMan 300, 360, 470, and 503 series readers have laser light.



If you need more information on the collection, reuse, and recycling systems, please contact your local or regional waste administration.

You may also contact your supplier for more information on the environmental performance of this product.

Warnings And Notices

⚠ CAUTION: IP protection is ensured only when all connectors are attached to cables or shielded by a sealing cap.

ℹ Note: For product support, contact <http://support.cognex.com>.

⚠ CAUTION: Use of controls or adjustments or performance of procedures other than those specified herein may result in hazardous radiation exposure.

- Do not attempt to service or repair this product - return it to Cognex for service.
- Do not permit anyone other than Cognex Corporation to service, repair, or adjust this product.
- Do not attempt to open or modify this device except as described in this document.
- Do not direct or reflect laser light toward people or reflective objects.
- Do not operate this device if it is damaged or if the covers or seals are missing or damaged.

This Laser Product is designated as Class 2 during all procedures of operation.

Wavelength	650 nm
Laser power for classification	< 1 mW
Beam Diameter	< 3 mm at aperture
Divergence	< 1.5 mrad

Mechanical Information

This section provides information on various mechanical features of the DataMan 50, DataMan 60, DataMan 70, DataMan 150, DataMan 260, DataMan 300, DataMan 360, DataMan 470, and DataMan 503 series readers, such as dimensions, lens replacement, mounting information, as well as thermal and environmental requirements.

DataMan 50 Reader Dimensions

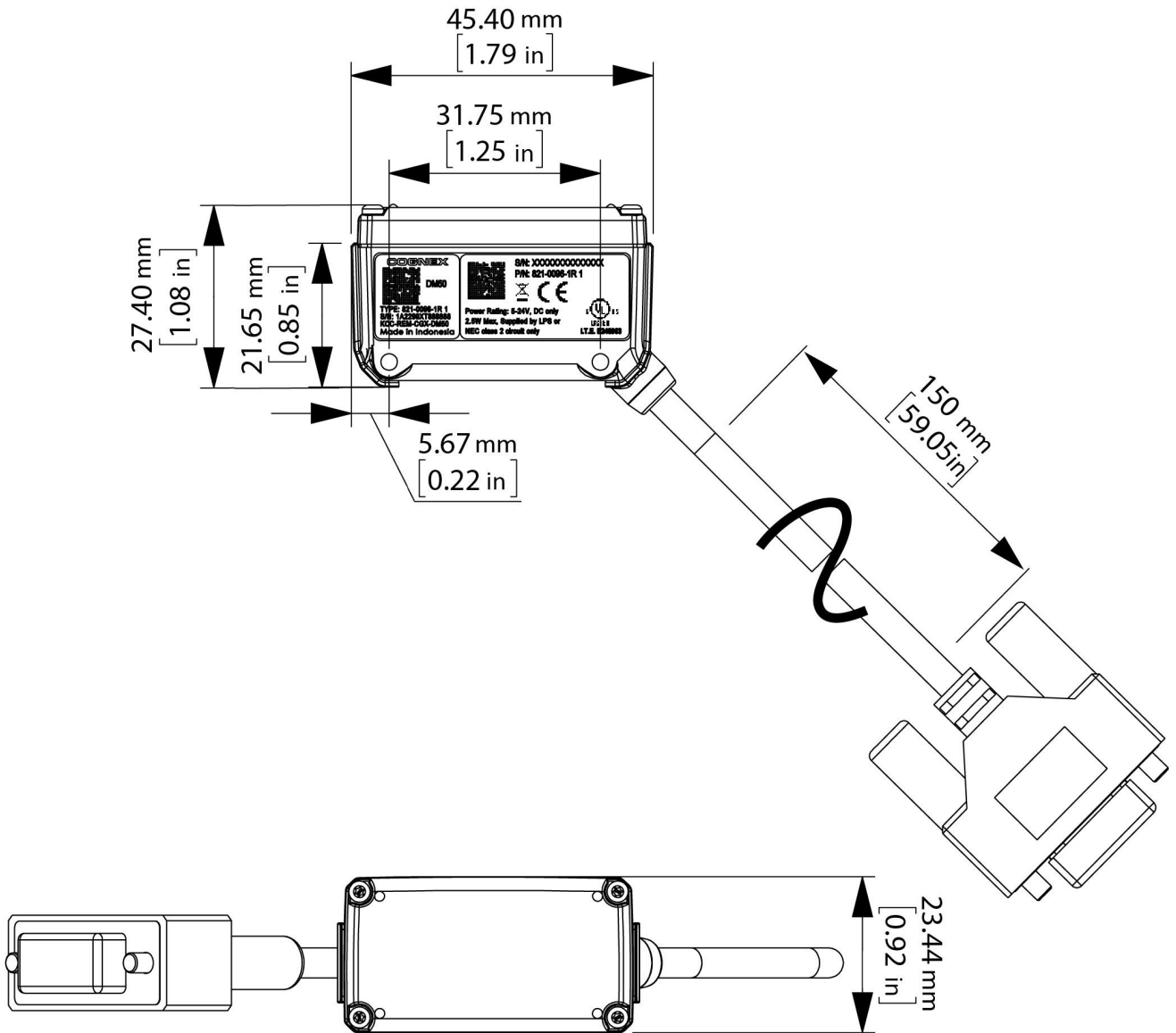

DataMan 60 Reader Dimensions

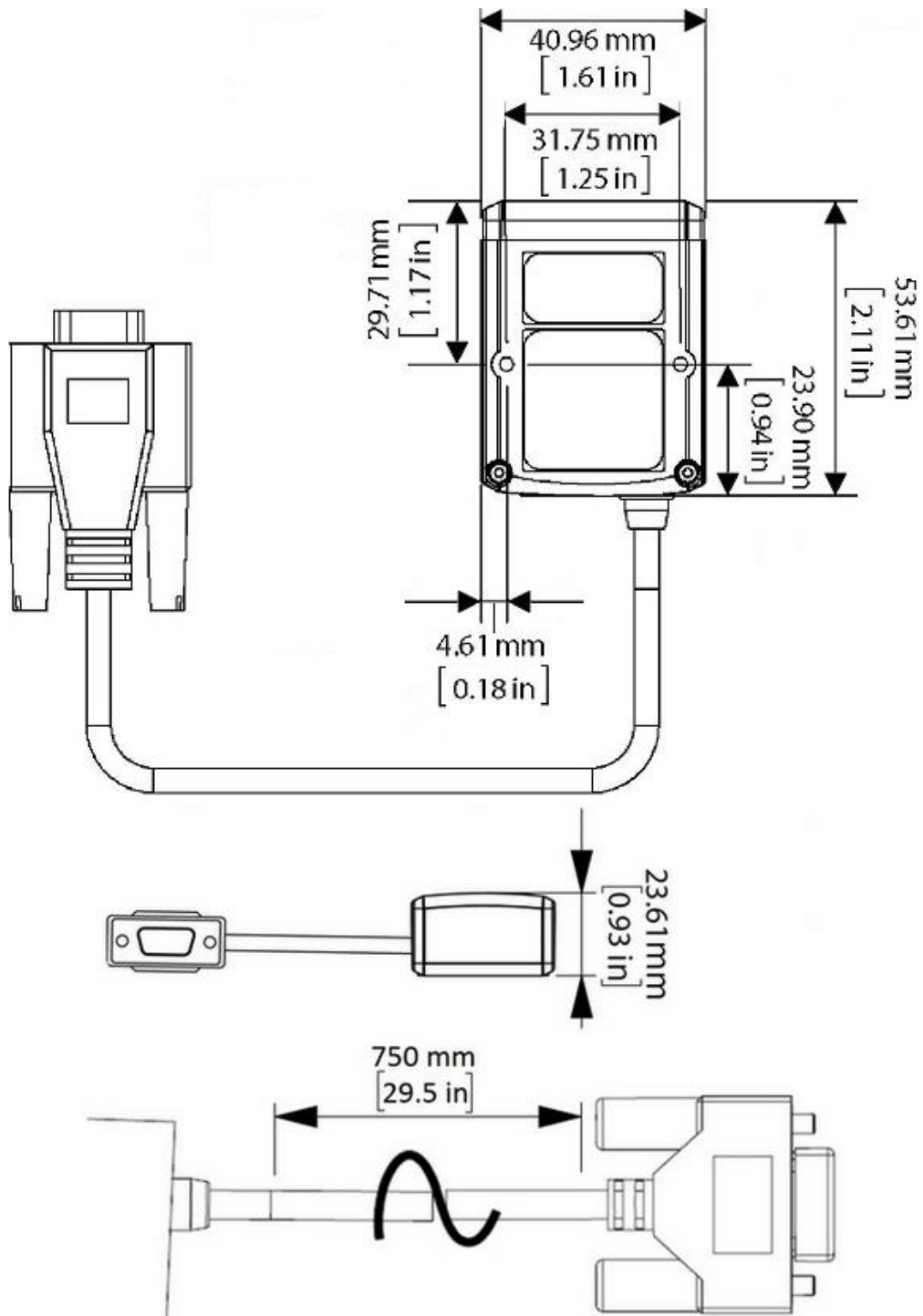

DataMan 70 Series Reader Dimensions

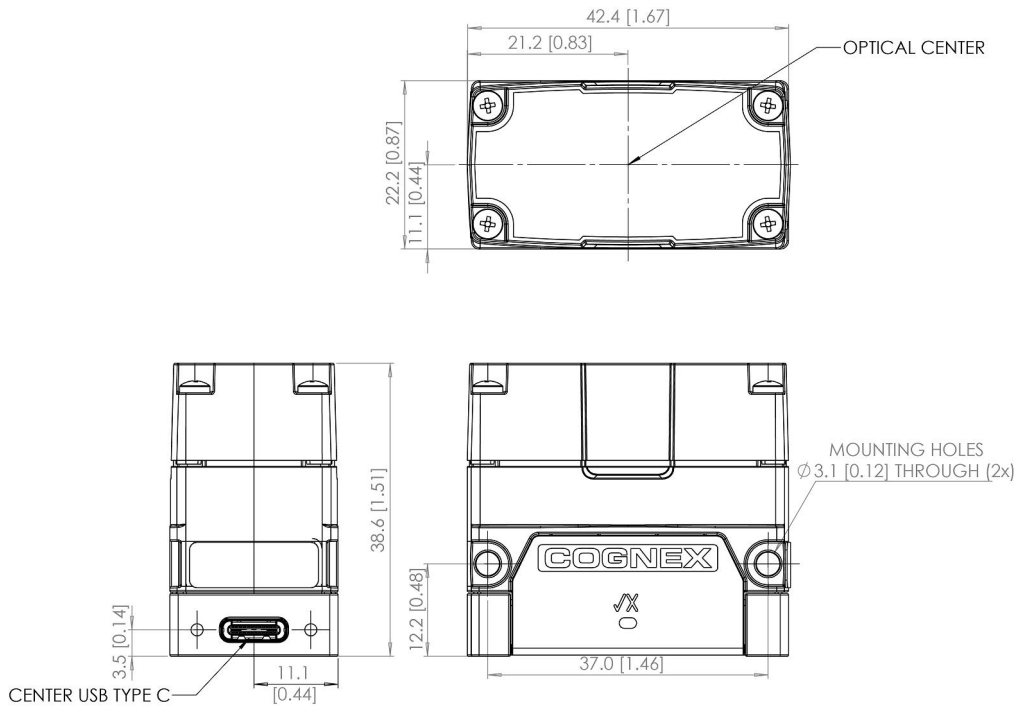

DataMan 150 Reader Dimensions

DataMan 150 dimensions in the straight configuration:

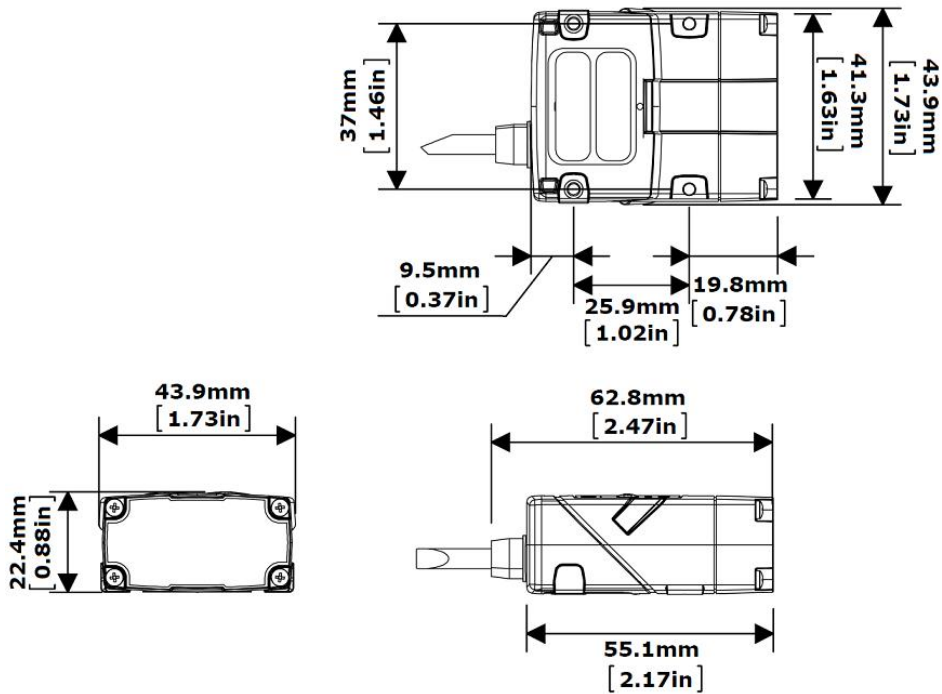

DataMan 150 dimensions in the angled configuration:

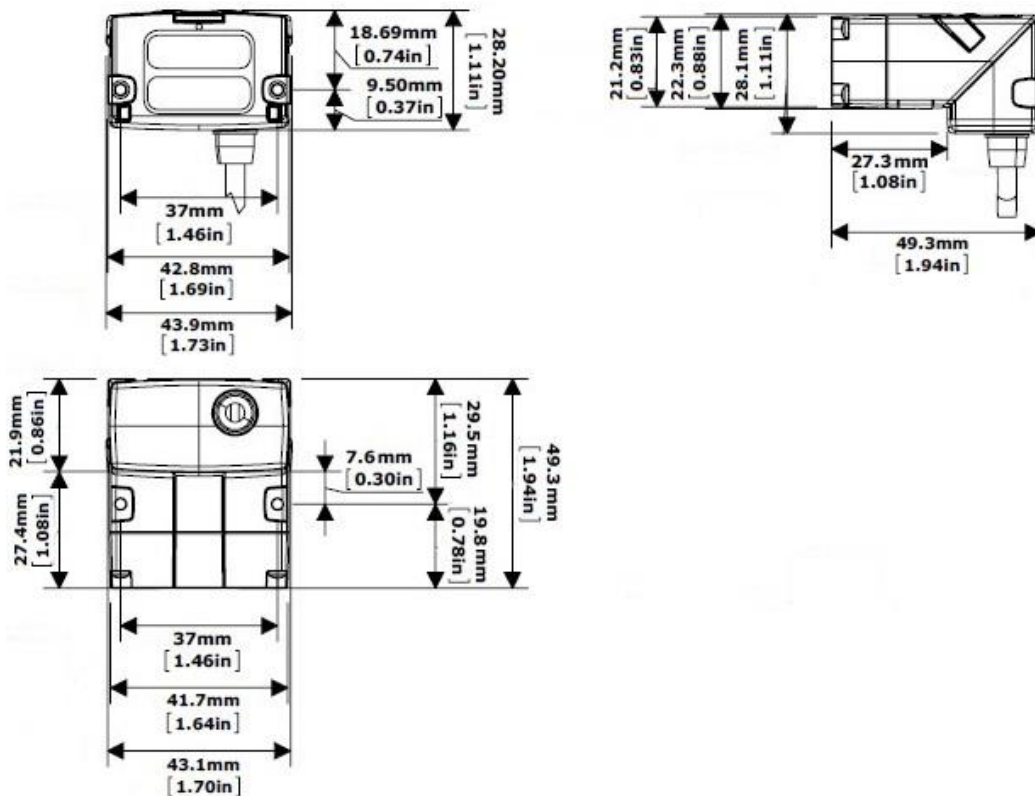

DataMan 260 Reader Dimensions

DataMan 260 dimensions in the straight configuration:

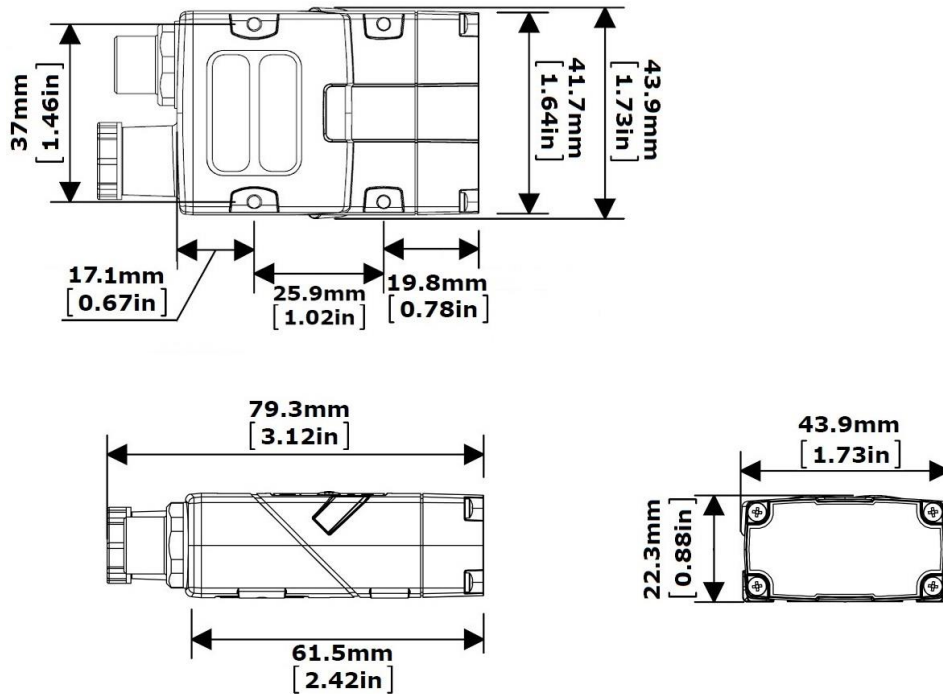

DataMan 260 dimensions in the angled configuration:

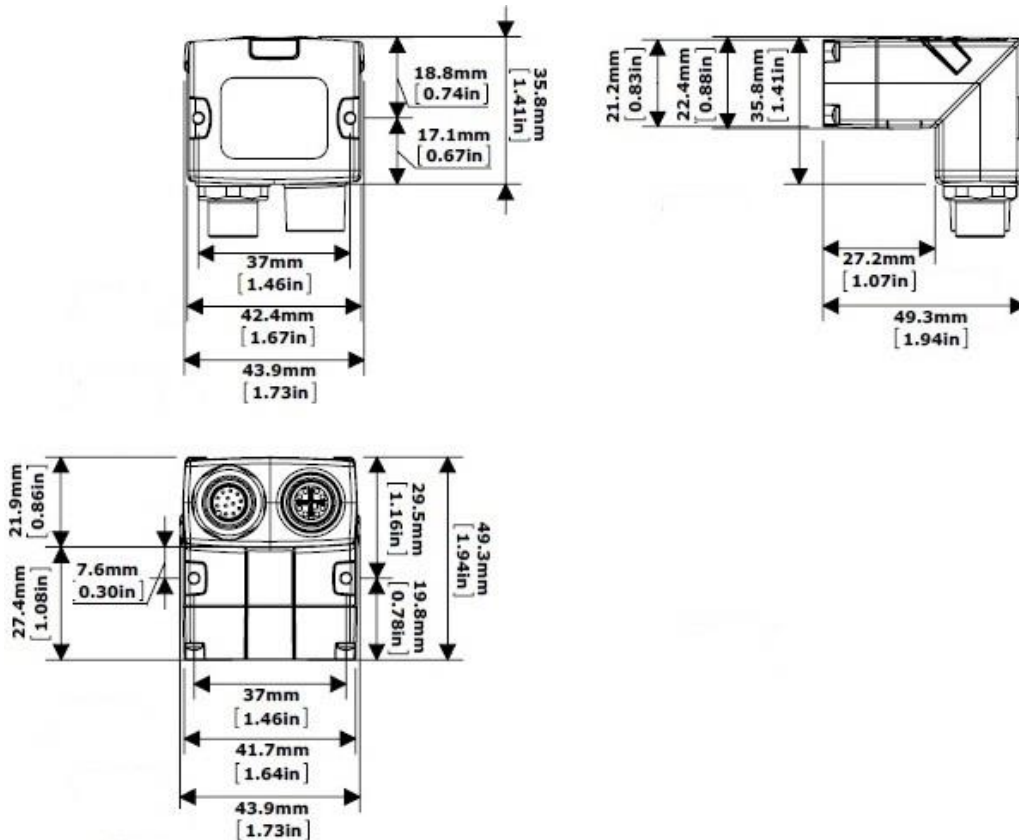

DataMan 280 Reader Dimensions

The following image shows the dimensions of DataMan 280, equipped with 6.2 mm lens:

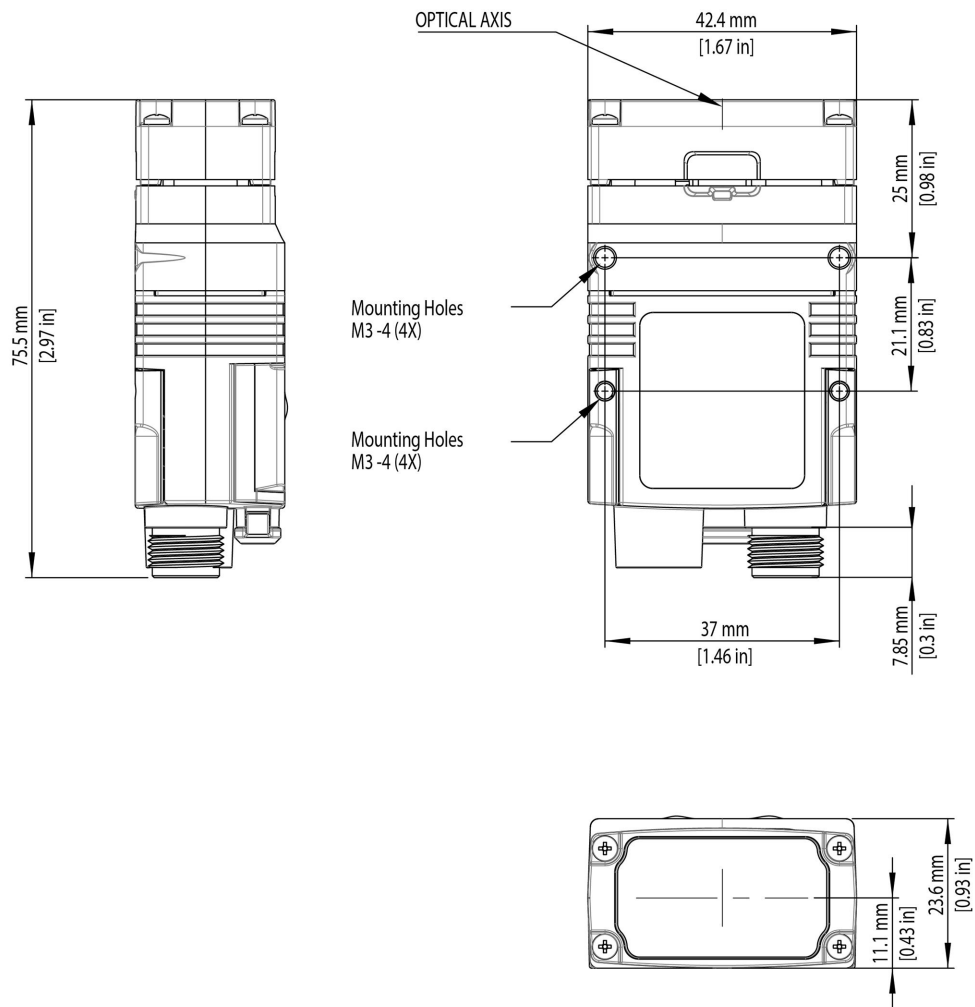

The following image shows the dimensions of DataMan 280 equipped with 16 mm lens:

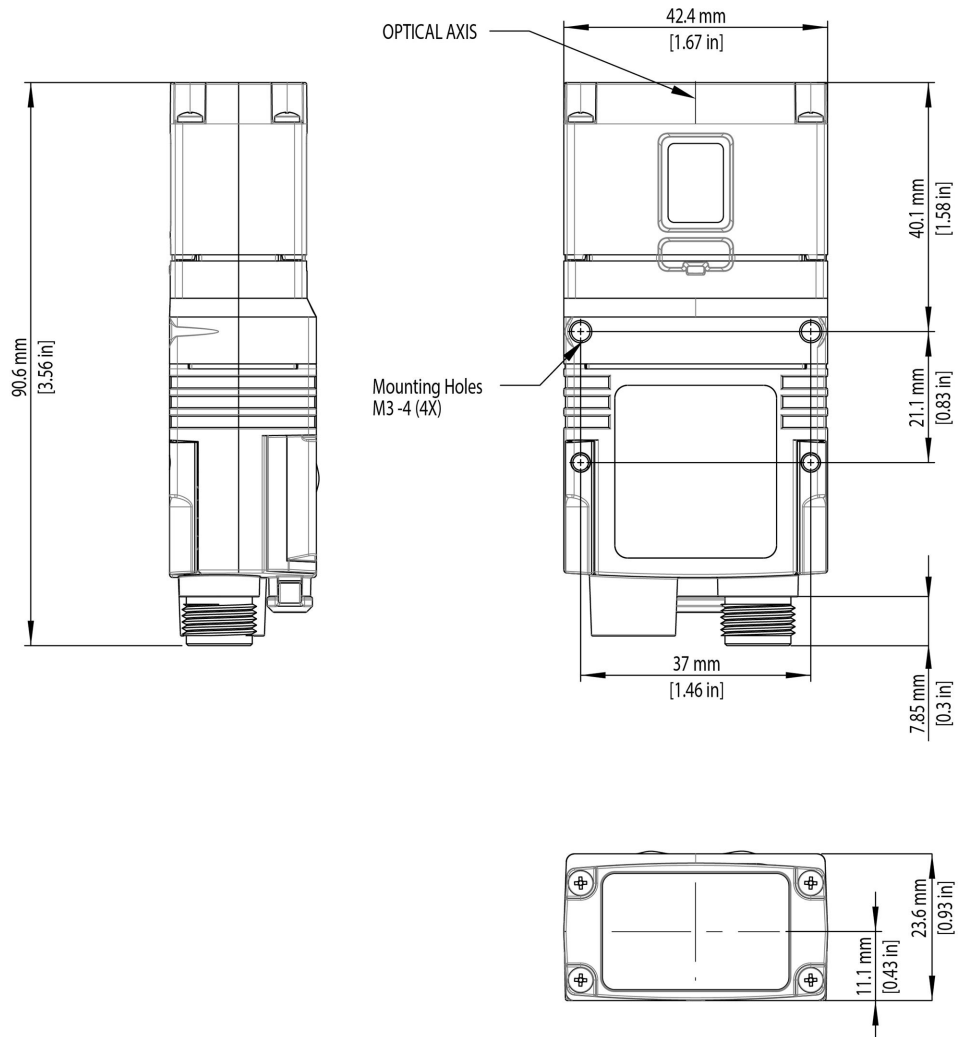

The following images show the dimensions of DataMan 280, equipped with L-shaped extension.
6.2 mm lens version:

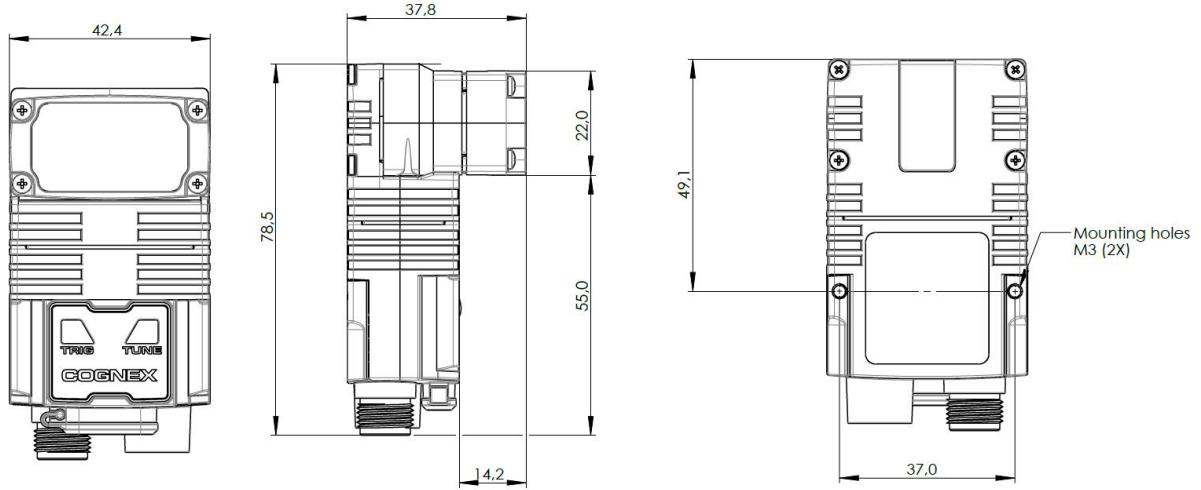

16 mm lens version:

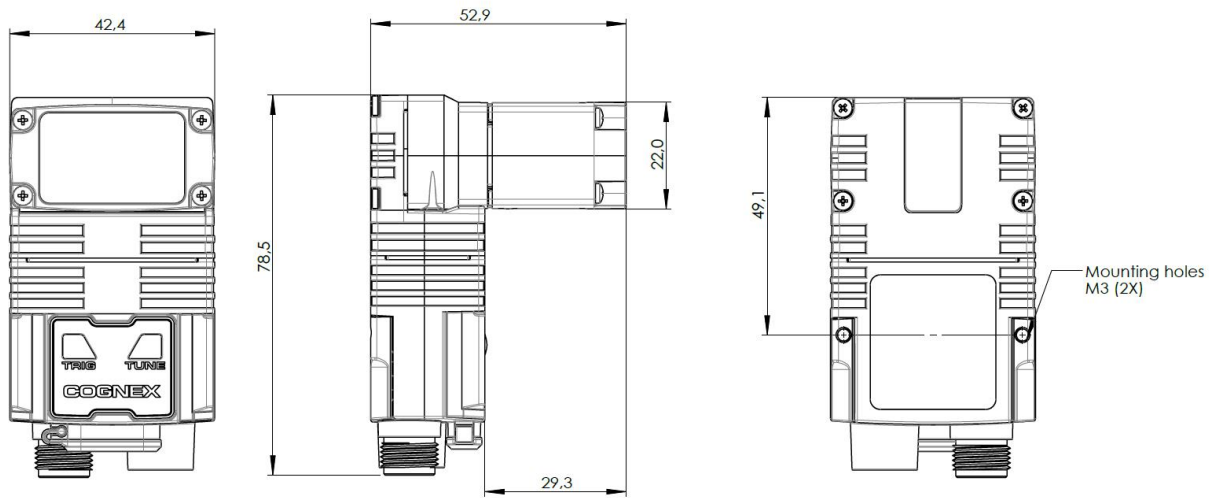

DataMan 300 Series Reader Dimensions

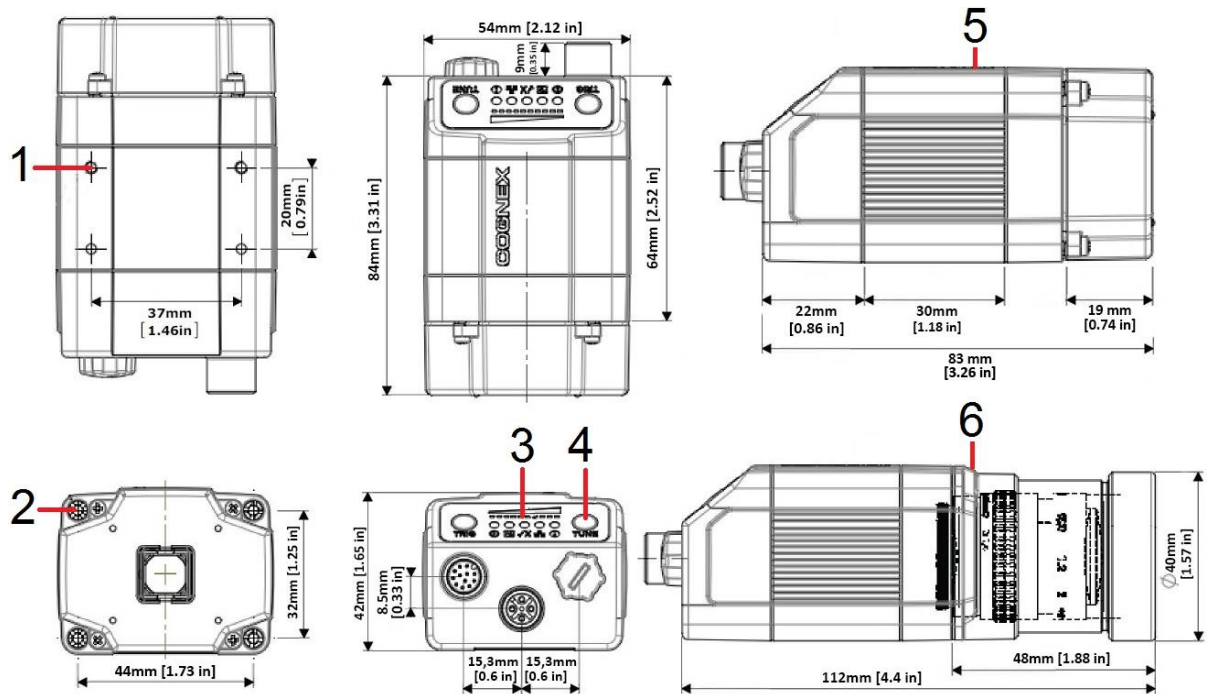

1	M3-5 (4x) mounting holes of the device
2	M3-6 (4x) mounting holes for external illumination
3	Illumination lights
4	Operating buttons
5	S-Mount (M12) Lens version
6	C-Mount Lens version

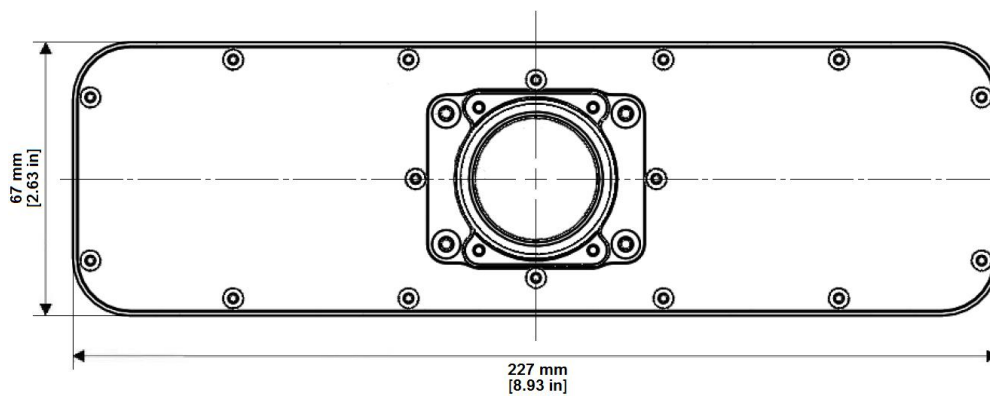

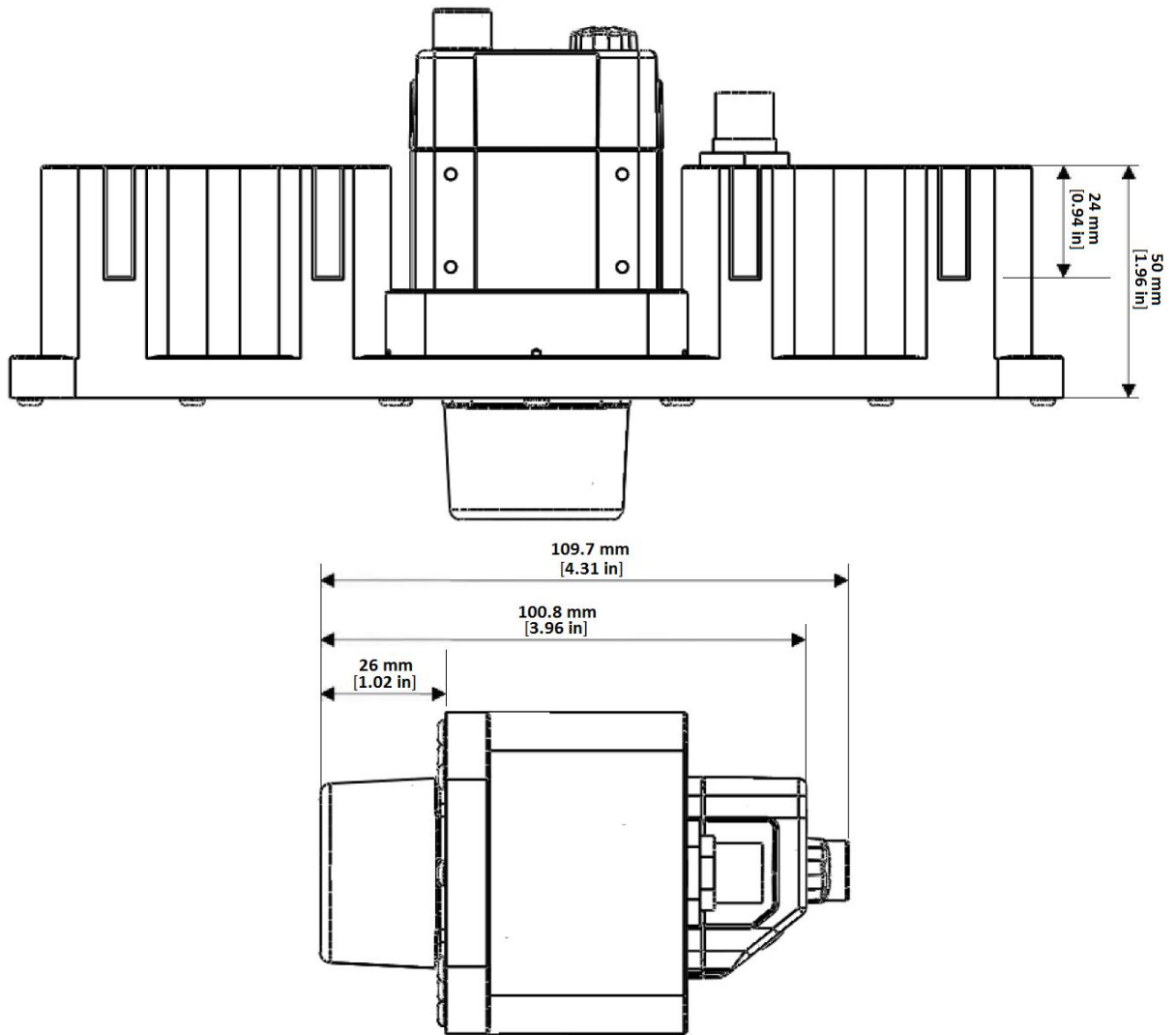

DataMan 360 Series Reader Dimensions

DataMan 360 dimensions without lens and with C-mount and S-mount lens options:

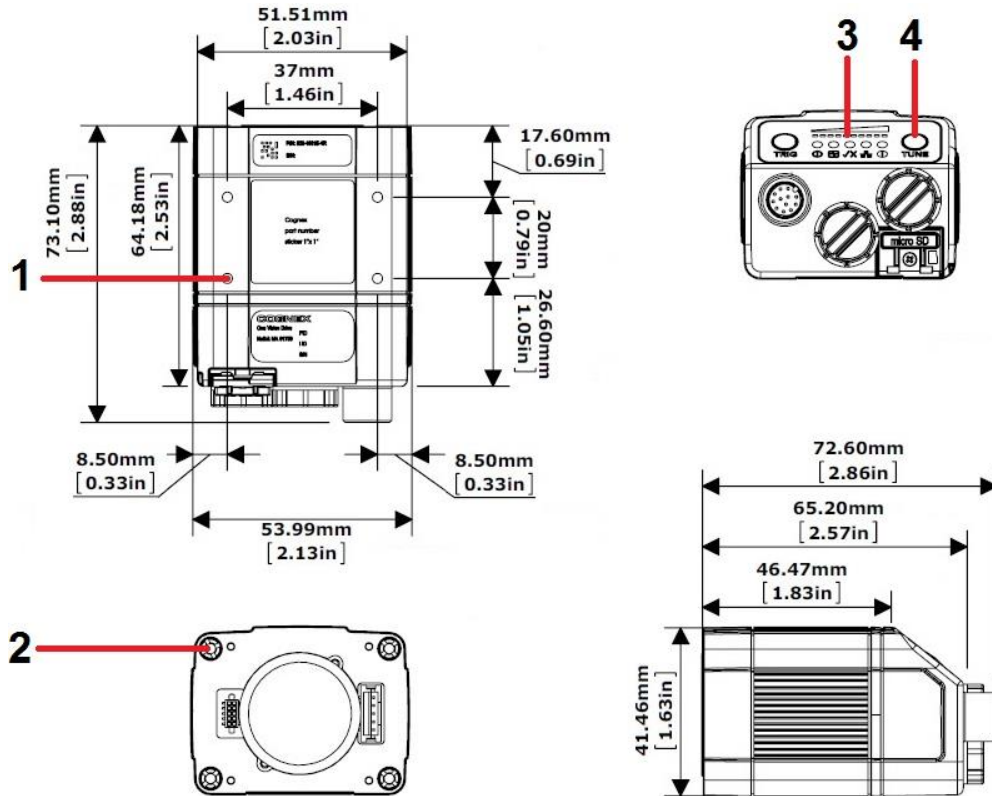

1	M3-5 (4x) mounting holes of the device
2	M3-6 (4x) mounting holes for external illumination
3	Illumination lights
4	Operating buttons

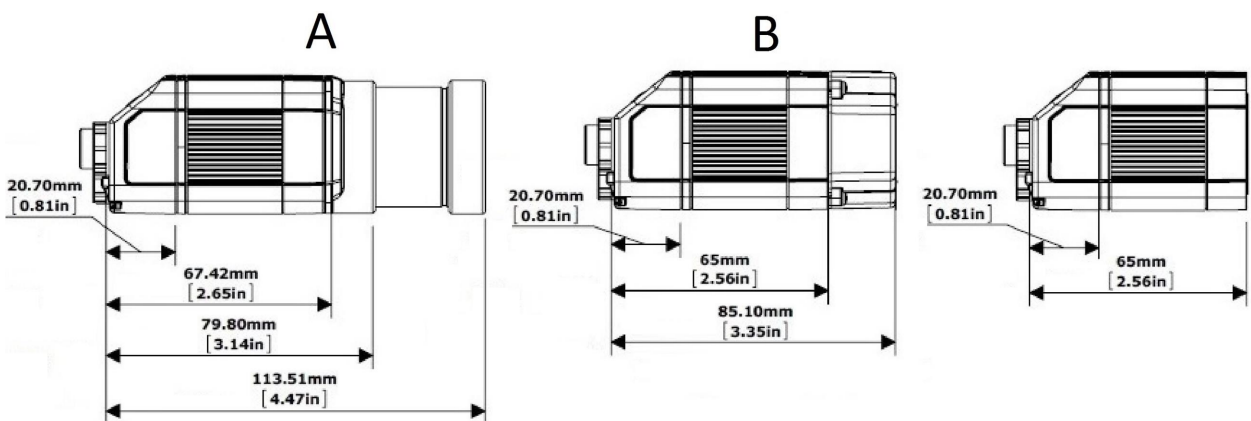

A	C-Mount Lens version
B	S-Mount (M12) Lens version

DataMan 370 Series Reader Dimensions

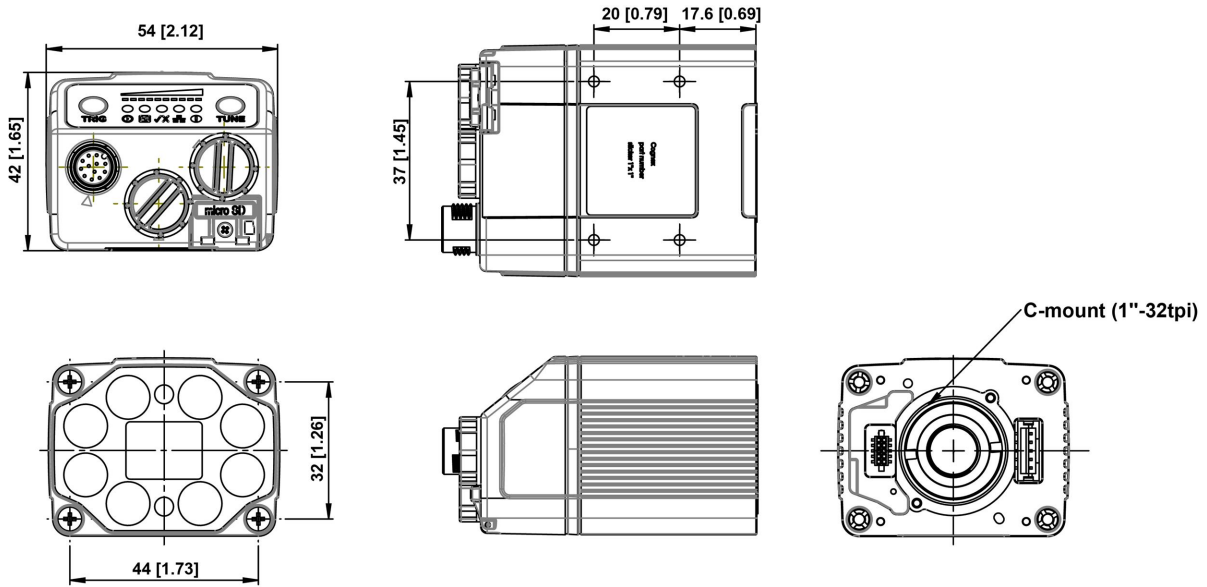

DataMan 370 Series Reader with High Power Integrated Light (HPIL)

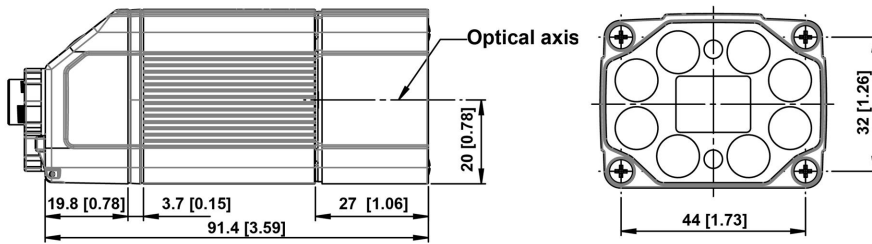

DataMan 370 Series Reader with High Power Illumination Accessory (HPIA)

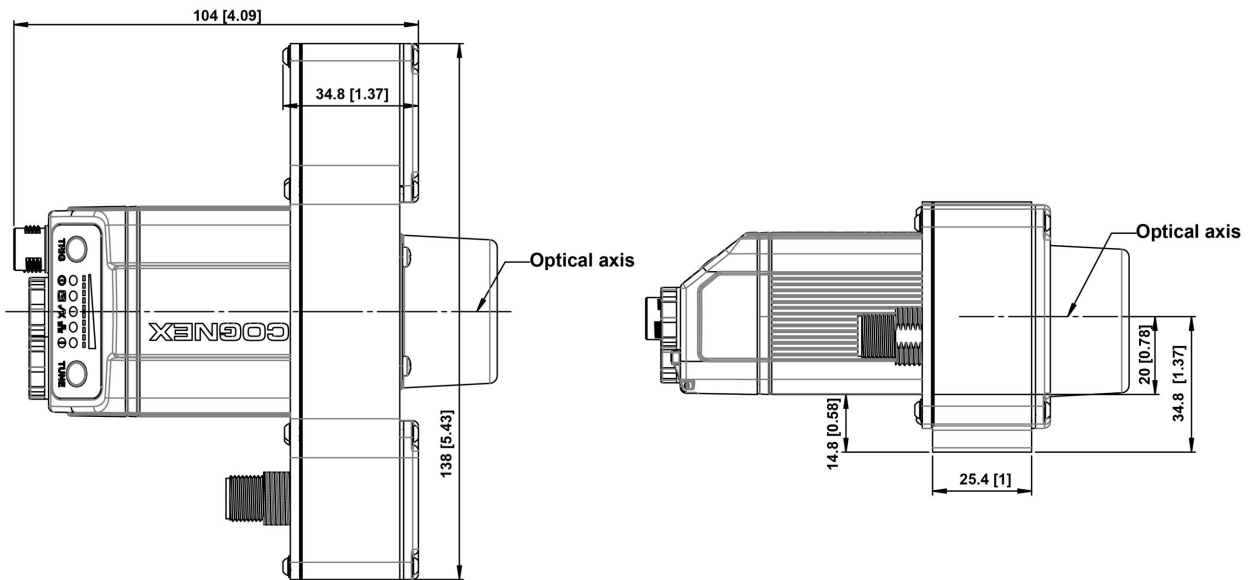

DataMan 370 Series Reader with High Power Integrated Torch (HPIT)

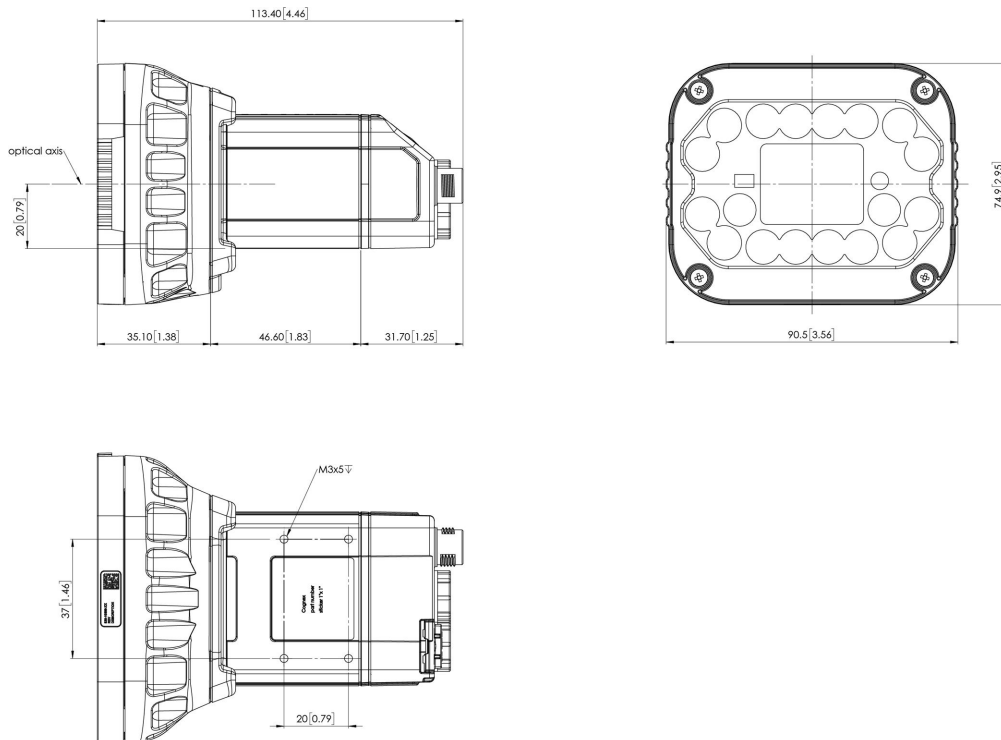

DataMan 470 Series Reader Dimensions

DataMan 470 Reader with High Power Integrated Light (HPIL)

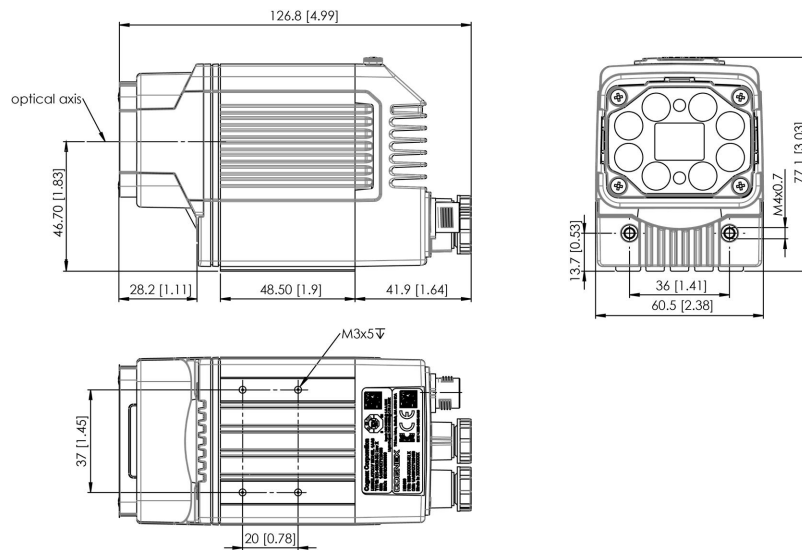

DataMan 470 Reader with High Power Illumination Accessory (HPIA)

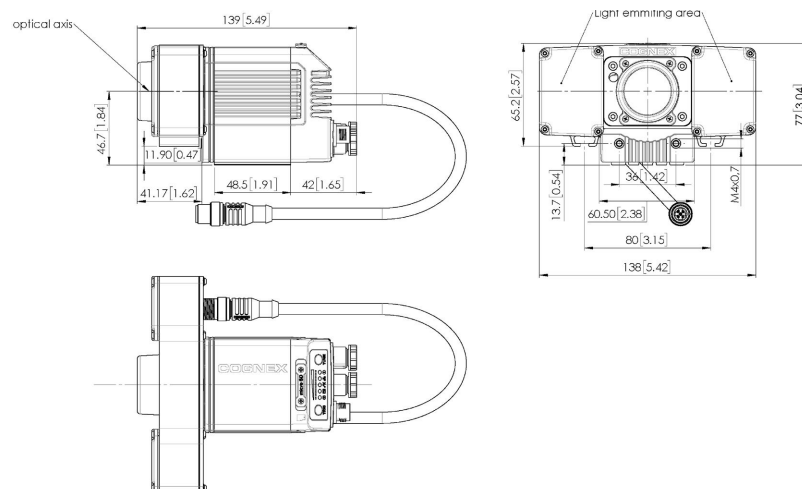

DataMan 470 Reader with High Power Integrated Torch (HPIT)

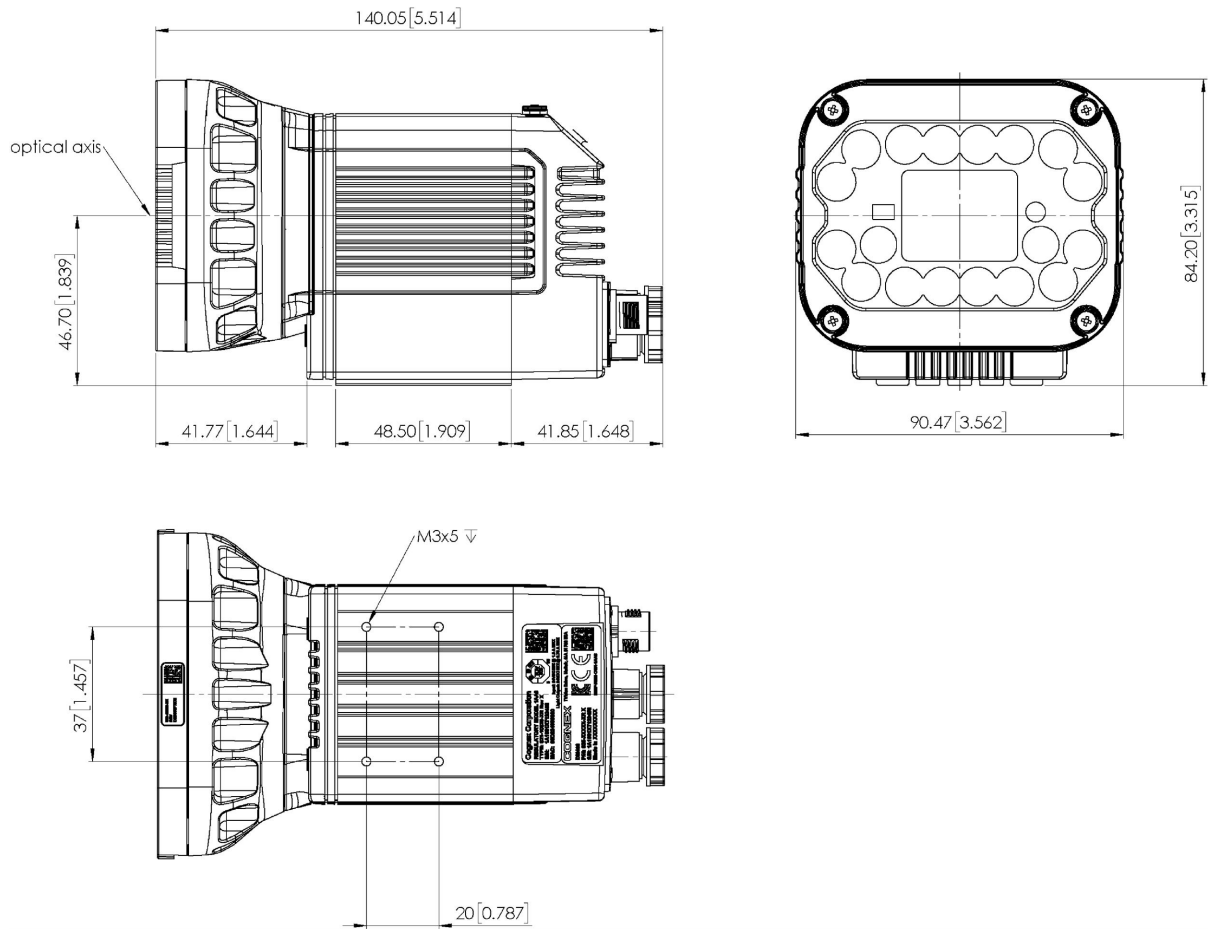

DataMan 503 Reader Dimensions

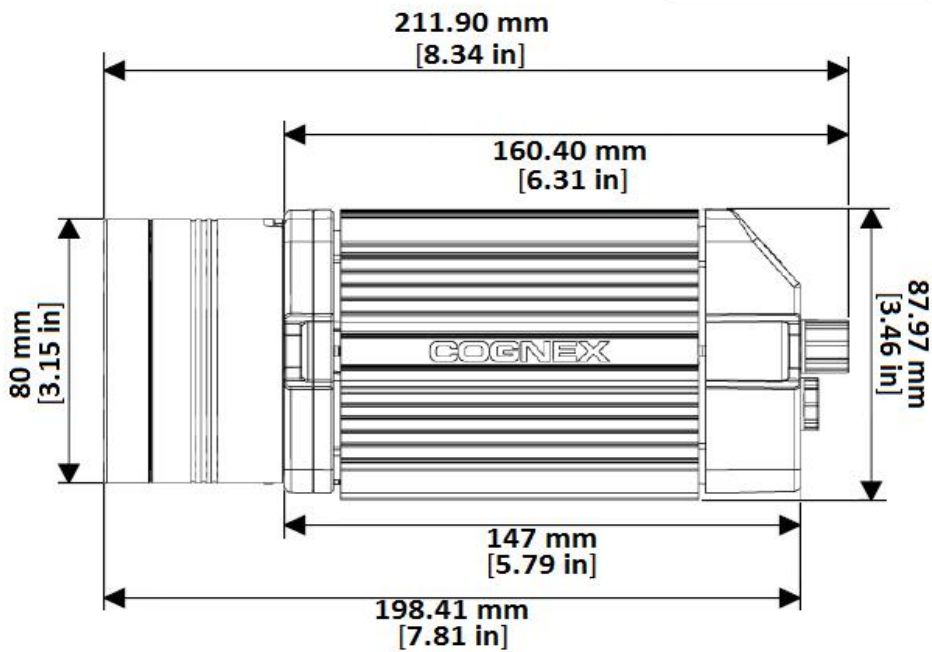
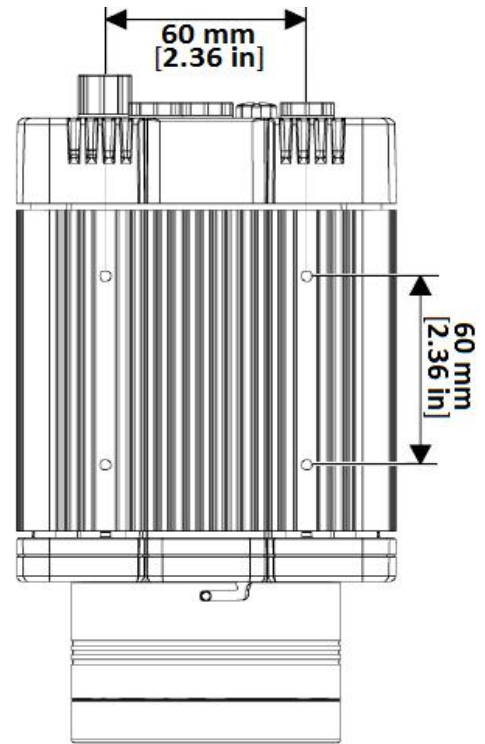
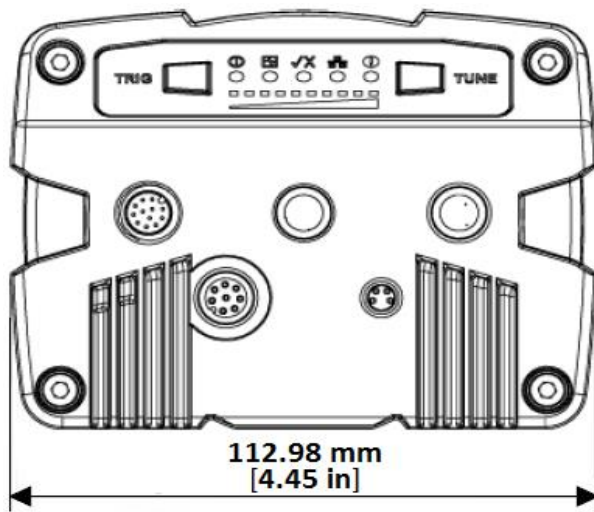

Service Procedures

DataMan 50 Service Procedures

DataMan 50 supports three distance ranges. Perform the following steps to set the focus position:

1. Remove the screws, washers, lens cover and rubber part.



2. Set focus by positioning a coin into the lens cap slit and turning the coin. Do not use a coin thicker than 2 mm. If no coin is available, use the edge of the back cover

Lens cap slit

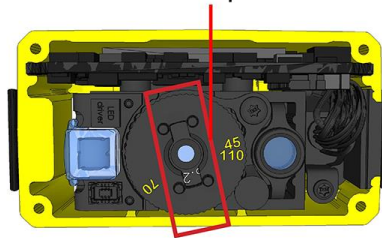

3. Make sure that the sealing and the sealing surface are clean before reassembling the lens cover.
4. Line up the holes with the icons, and attach the rubber part to the front window.

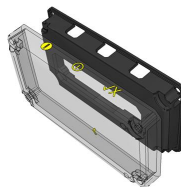

5. Attach both to the housing and add the washers and screws.

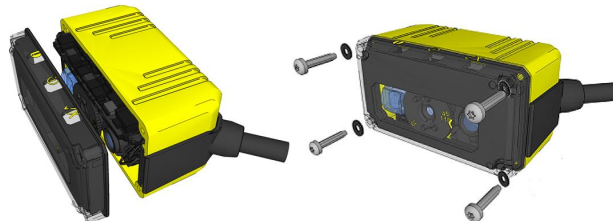

6. Tighten screws in the order shown below. The maximum torque for the cover screws is 5 N-cm (0.4 pound-inch). The yellow arrow on the cover indicates the selected focus position.

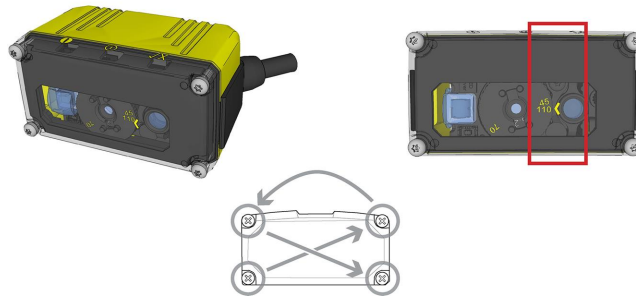

DataMan 60 Service Procedures

DataMan 60 can operate in one of three distance ranges. Perform the following steps to set the focus position:

1. Remove the lens cover.



2. Set the focus position to 45, 70, or 110: turn the lens cap clockwise (45->70->110) to focus to a larger distance; turn the lens cap counter-clockwise (110->70->45) to focus to a shorter distance.

3. Reattach the front cover.

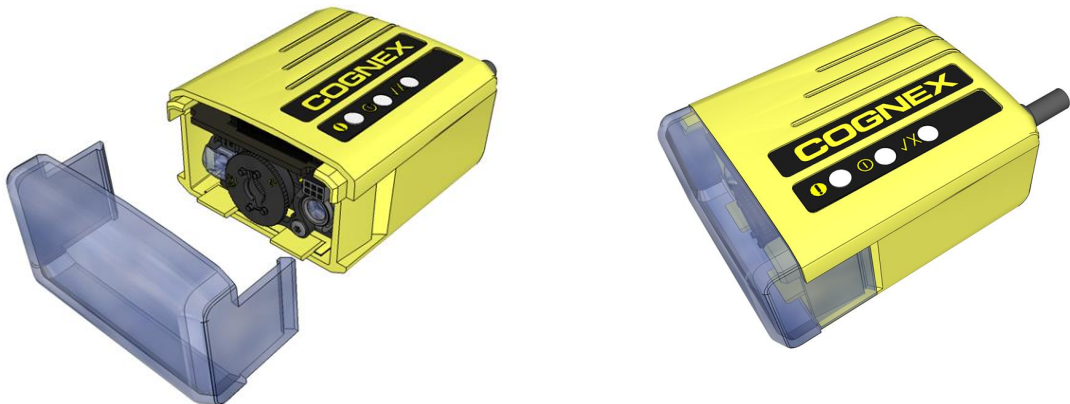

DataMan 70 Service Procedures

DataMan 70 can operate in one of three distance ranges. Follow the steps below to set the focus position.

1. Remove the screws and the front cover.

DM70 with 6.2 mm lens

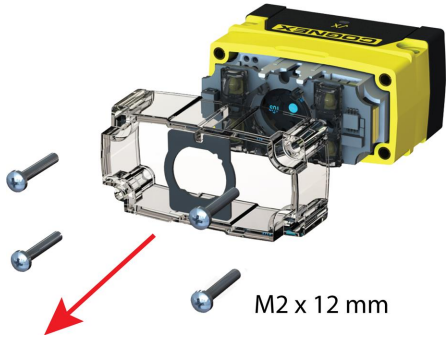

DM70 with 16 mm lens

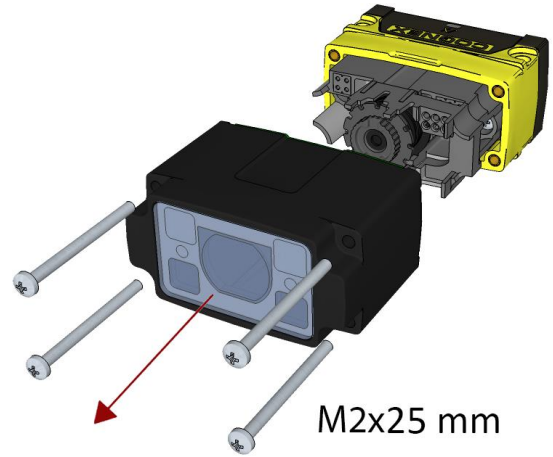

2. Using a flathead screwdriver, set the focus position from the front. Always turn clockwise to focus to a larger distance and counterclockwise to focus to a shorter distance.

DM70 with 6.2 mm lens

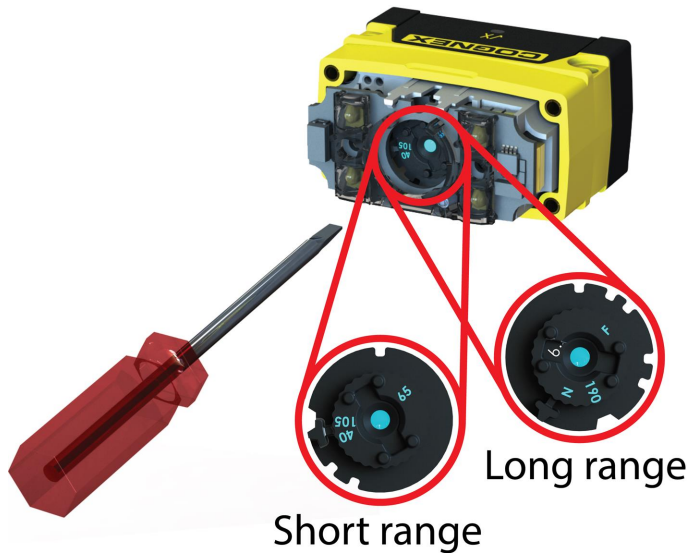

DM70 with 16 mm lens



Note: If an optical filter has been mounted, first disconnect the DataMan 70 reader from power and remove the illumination module with the filter before adjusting the focus.

3. Remount the front cover. Observing the tightening sequence below, tighten all four screws to 9 Ncm using a torque wrench.

DM70 with 6.2 mm lens

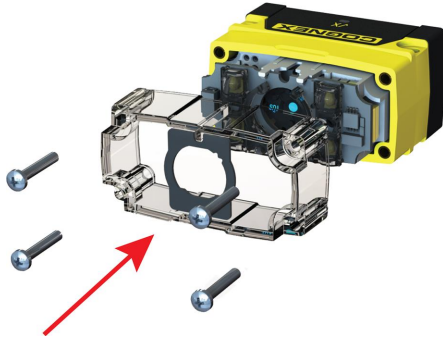

DM70 with 16 mm lens

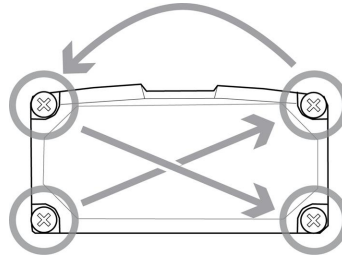
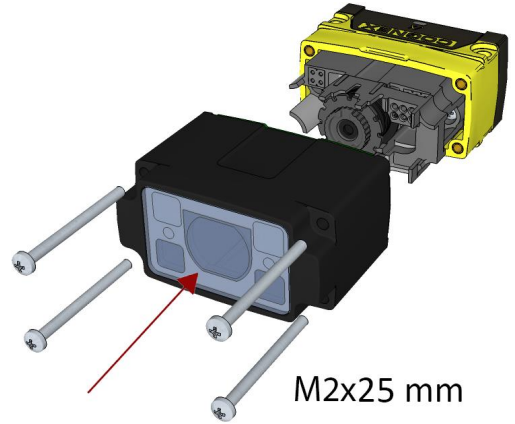

i Note: The rib in the front cover must be oriented to the top side.

DataMan 150 and 260 Series Service Procedures

Setting the Focus Position of a DataMan 150 or DataMan 260 Reader

DataMan 150 and 260 can operate in one of three distance ranges. Follow the steps below to set the focus position.

Note: The following steps describe service procedures for both the DataMan 150 and the 260 readers, but the images show only the DataMan 260.

1. Remove the screws and the front cover.

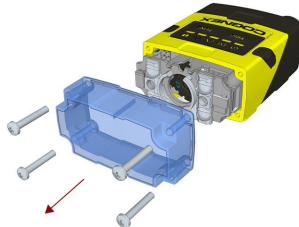

2. Using a flathead screwdriver, set the focus position from the front. Always turn clockwise to focus to a larger distance and counterclockwise to focus to a shorter distance.

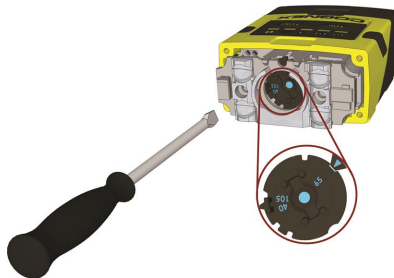

Note: If an optical filter has been mounted, first disconnect the DataMan 150 or 260 reader from power and remove the illumination module with the filter before adjusting the focus.

3. Remount the front cover. Observing the tightening sequence below, tighten all four screws to 9 Ncm using a torque wrench.

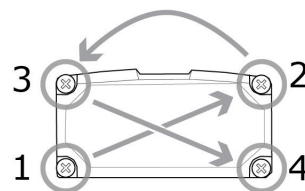
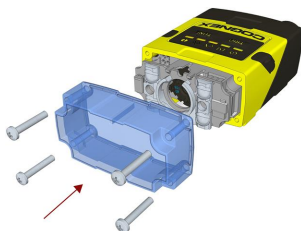

Note: If you use an optical filter and the illumination was removed, remount the illumination module first and then remount the front cover.

Note: The rib in the front cover must be oriented to the top side.

Changing from a 6.2 mm Lens to a 16 mm Lens on a DataMan 150 or DataMan 260 Reader

Perform the following steps to change a 6.2 mm lens to a 16 mm lens on your DataMan 150 or 260 reader.

Note: Disconnect the DataMan 150 or 260 reader from power before changing lenses.

WARNING: This modification must be made in a dust-free and ESD safe area.

Note: The following steps describe service procedures for both the DataMan 150 and the 260 readers, but the images show only the DataMan 260.

1. Remove the front cover: unscrew the four screws and take off the LED cover.

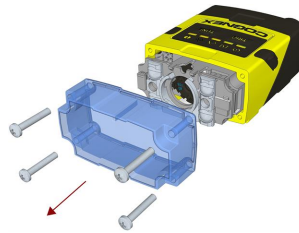

2. Remove the illumination module.

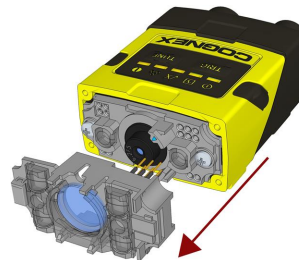

3. Unscrew the two Phillips head screws and remove the 6.2 mm lens mount.



4. Attach the 16 mm lens mount.

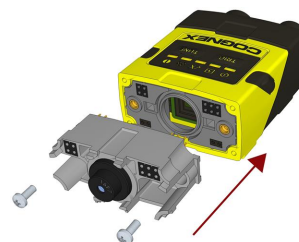

5. Fasten the two Phillips head screws to 0.06 Nm using a torque wrench.

- In the case of a manual focus lens, press the 16 mm lens cap onto the lens. The lens has 12 cutouts so it can be locked in steps of 30 degrees.



- Attach the illumination board.

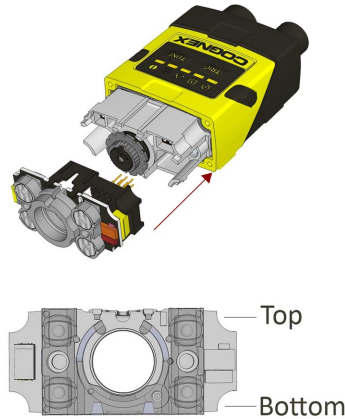

Note: Take care to attach the illumination with the right orientation.

- Attach the extended front cover. Observing the tightening sequence below, tighten all four screws to 9 Ncm using a torque wrench.

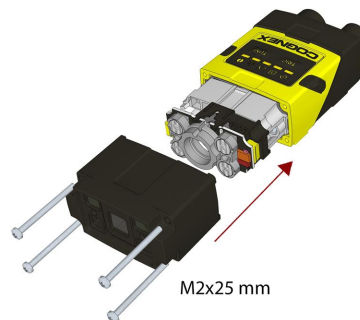

Note: The rib in the front cover must be oriented to the top side.

Installing an Optical Filter

Perform the following steps to install an optical filter in the optics module of your DataMan 150 or DataMan 260 reader.

Note: Disconnect the reader from power before installing an optical filter.

Observe the following constraints on the filter:

- Diameter (\varnothing): $12.3 \text{ mm} < \varnothing < 12.7 \text{ mm}$
- Thickness (t): $1.6 \text{ mm} < t < 2 \text{ mm}$ filter

i Note: The following steps describe service procedures for both the DataMan 150 and the 260 readers, but the images show only the DataMan 260.

1. Remove the front cover: unscrew the four M2x12 mm Phillips Pan head screws and take off the LED cover.

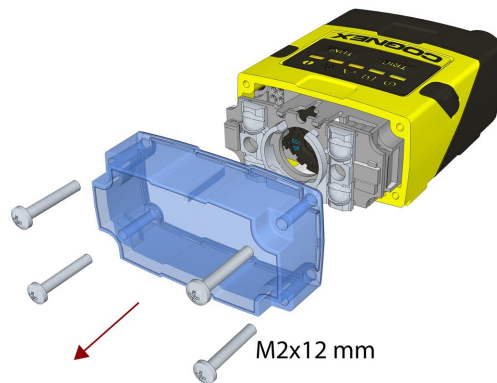

2. Insert the filter at the bottom side of the round opening in the transparent plastic part.

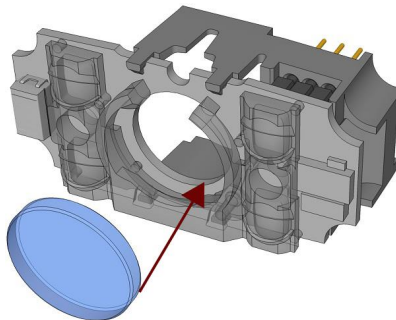

3. Push the top side of the filter firmly until it is sitting flat against the PCB.

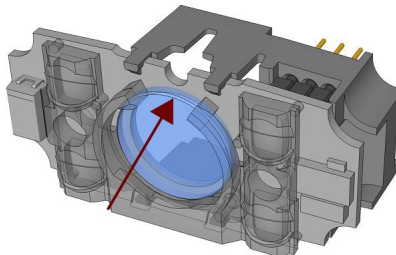

i Note: Use finger to push the filter in and then a q-tip to clean the filter, or use a q-tip to push the filter into place.

- Attach the front cover. Observing the tightening sequence below, tighten all four M2x12 mm Phillips Pan head screws to 9 Ncm using a torque wrench.

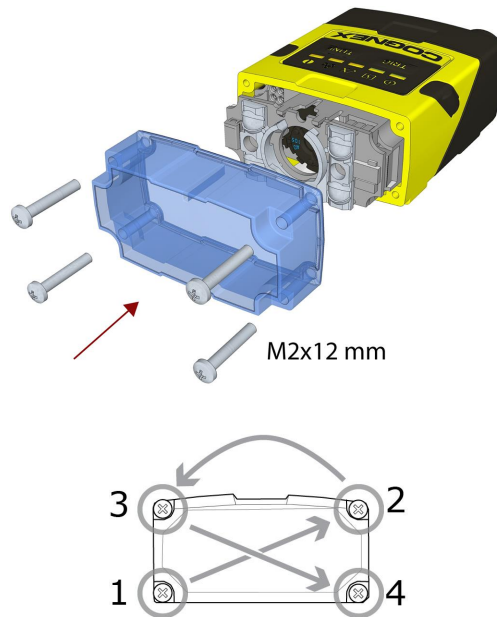

Note: The rib in the front cover must be oriented to the top side.

Installing a Liquid Lens

Perform the following steps to install a liquid lens on your DataMan 150 or DataMan 260 reader.

Note: Disconnect the reader from power before installing the liquid lens.

Note: The following steps describe service procedures for both the DataMan 150 and the 260 readers, but the images show only the DataMan 260.

1. Remove the front cover: unscrew the four M2x12 mm Phillips Pan screws and take off the LED cover.

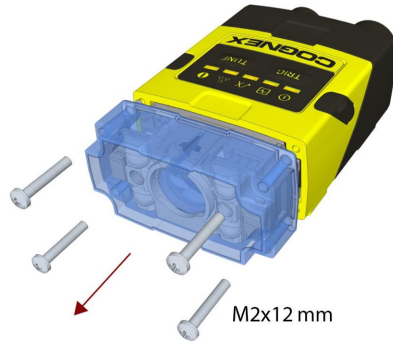

2. Remove the illumination module.



3. Turn the lens cap to the 105 mm position.



4. Remove the lens cap from the imager lens by pulling it.



Note: Do not rotate the imager lens while the lens cap is removed. Otherwise, focus calibration will be lost.

5. Attach the liquid lens accessory by aligning the 2x2 connectors of the liquid lens with the 2x2 sockets on the optics mount.



6. Press the liquid lens onto the imager lens until you reach the stop.



7. Reattach the illumination.

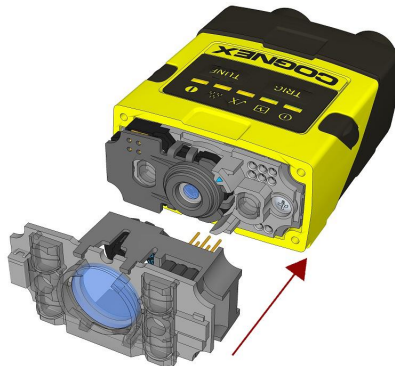

- Attach the front cover. Observing the tightening sequence below, tighten all four M2x12 mm Phillips Pan screws to 9 Ncm using a torque wrench.

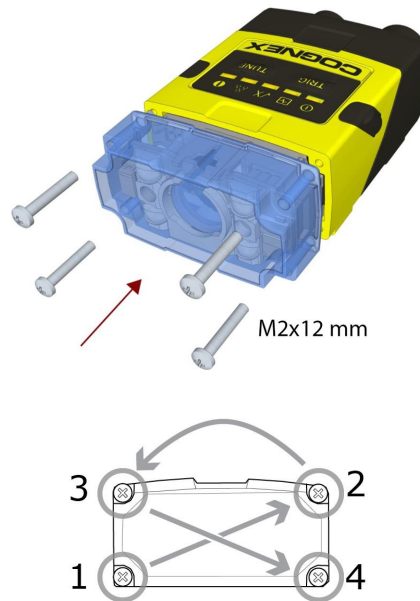

Note: The rib in the front cover must be oriented to the top side.

Note: The DataMan 150 and the DataMan 260 liquid lens must be calibrated after field exchange. This can be done under **Focus Settings** in the DataMan Setup Tool. For more information, see the **DataMan Questions and Answers** document. **A reboot is required for the lens to operate with the new settings.**

Changing to an Illumination with a Different Color

Perform the following steps to change the illumination.

Note: Disconnect the reader from power before changing to an illumination with a different color.

Note: The following steps describe service procedures for both the DataMan 150 and the 260 readers, but the images show only the DataMan 260.

1. Remove the front cover: unscrew the four screws and take off the LED cover.

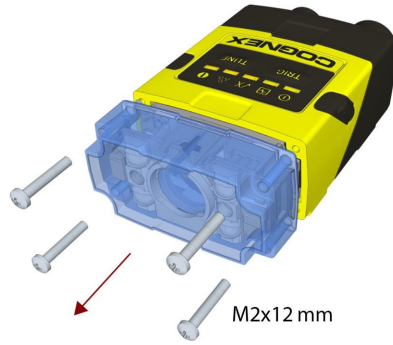

2. Remove the illumination module.

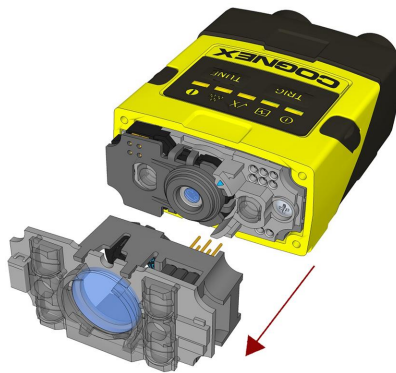

3. Attach a new color illumination module.

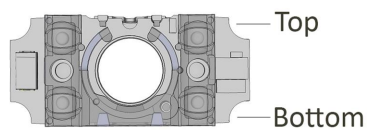
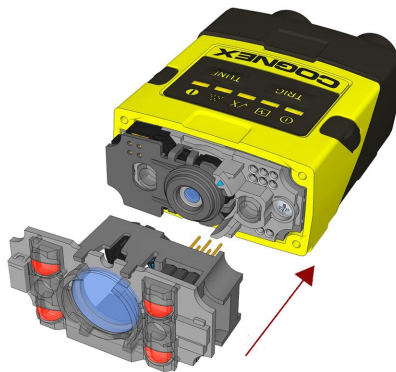

Note: Make sure you attach the illumination with the right orientation.

- Attach the front cover. Observing the tightening sequence below, tighten all four screws to 9 Ncm using a torque wrench.

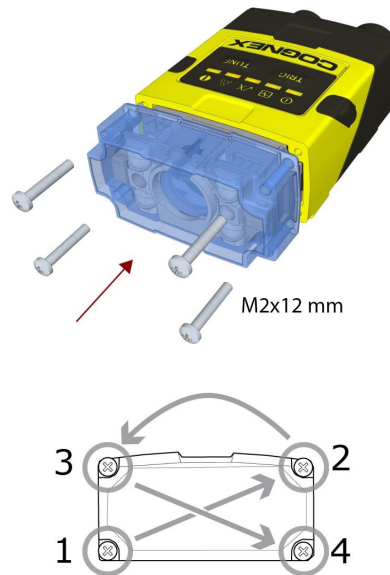

Note: The rib in the front cover must be oriented to the top side.

DataMan 280 Installing and Changing Lenses

This section provides an overview about installing and changing different kinds of lenses:

- Installing a C-Mount Lens.
- Changing a 6.2 mm Lens to a 16 mm Lens.
- Installing a High Speed Liquid Lens.

Note: Use a Phillips screwdriver with drive size #1 for all Phillips screws that are reachable from the front side.

Note: Disconnect the reader from power before changing lenses or mounts.

CAUTION: Perform all lens modification procedures in a dust-free and ESD safe area.

DataMan 280 Installing C-Mount Lens

1. Unscrew the four M2x12mm Phillips Pan head screws, then take off the metal cover from the reader.

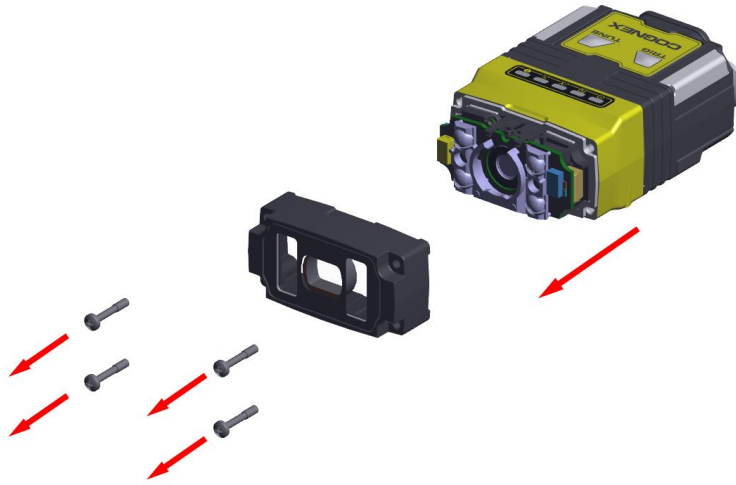

2. Remove the illumination module.



3. Unscrew the two M2x5mm Phillips head screws, remove the 6.2 mm lens mount and the 6.2 mm lens.



- Place the C-Mount cover on the front of the device, and tighten the screws.

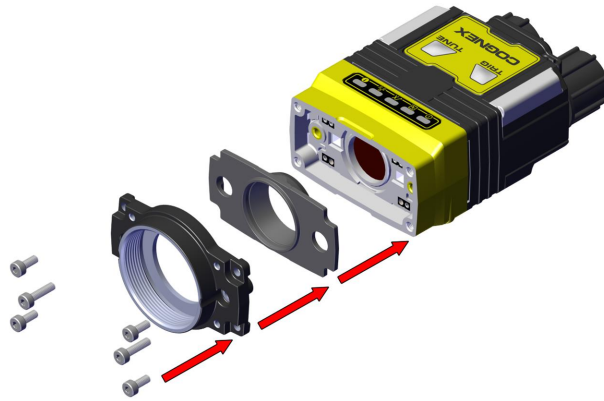

Note:

Observing the tightening sequence below, tighten all six M2 x 12 mm Phillips Pan screws to 12 Ncm using a torque wrench.

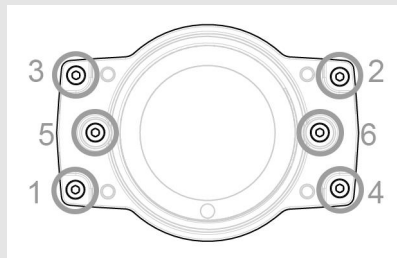

- Place the lens cover adapter plate on the C-Mount cover, and tighten the screws.



6. Thread the lens into the reader.



7. Screw the lens cover onto the lens cover adapter.

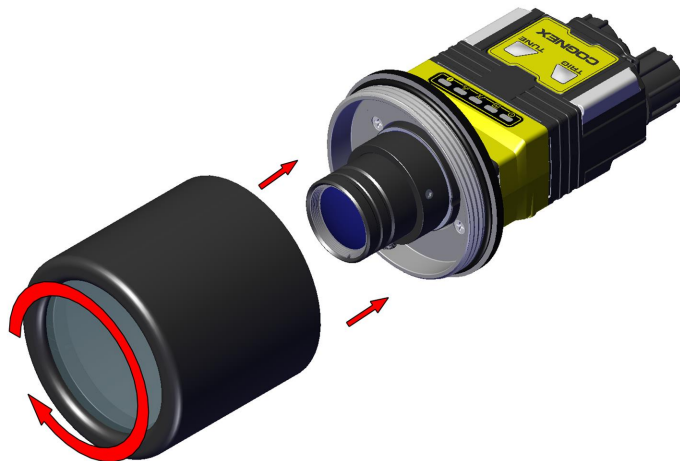

DataMan 280 Changing 6.2 mm Lens to 16 mm Lens

This section provides a step-by-step process for changing the 6.2 mm lens to a 16 mm lens on the reader.

1. Unscrew the four M2x12mm Phillips Pan head screws, then take off the metal cover from the reader.

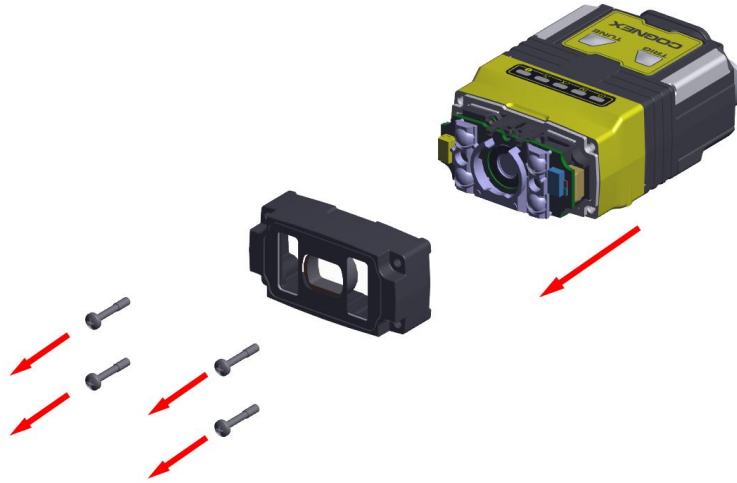

2. Remove the illumination module.



3. Unscrew the two M2x5mm Phillips head screws, remove the 6.2 mm lens mount and the 6.2 mm lens.



4. Attach the 16 mm lens mount and lens, and screw in the two M2x5mm Phillips head screws. Focus, if necessary.

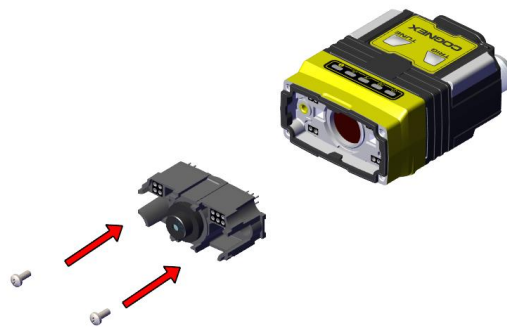

5. Attach the 16 mm lens illumination module.

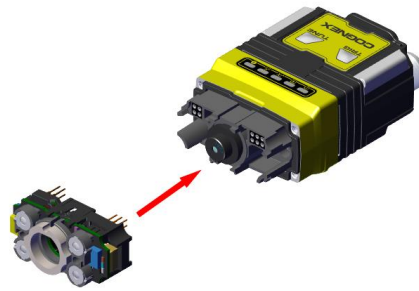

6. Attach the 16 mm lens front cover.

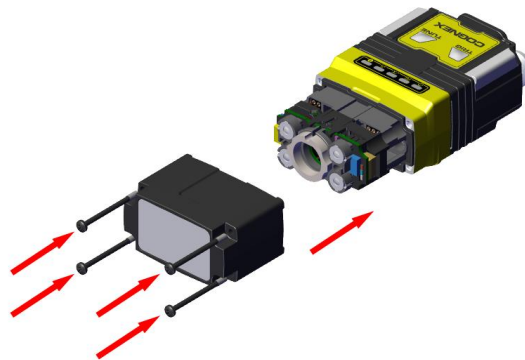

Note: The rib in the front cover must be oriented to the top side.

Note: Observing the tightening sequence below, tighten all four M2 x 12 mm Phillips Pan screws to 16 Ncm using a torque wrench.

Note:

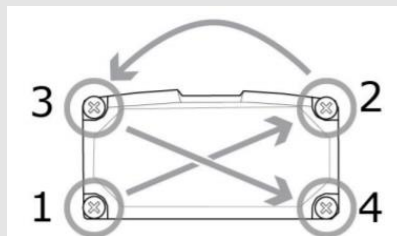

DataMan 280 Installing High Speed Liquid Lens

This section shows the process of installing a liquid lens onto the DataManModel Number with a 6.2 mm lens.

1. Unscrew the four M2 x 12 mm Phillips Pan head screws, then take off the metal cover from the reader.

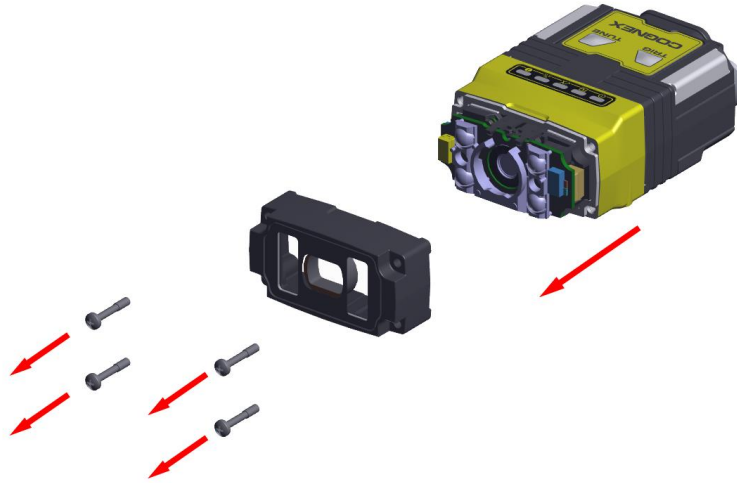

2. Remove the illumination module.



3. Turn the lens cap to the 105 mm position.



- Carefully remove the lens cap from the imager lens.



Note: In order not to lose focus calibration, do not rotate the imager lens while the lens cap is removed.

- Attach the liquid lens accessory by aligning the 2x2 connectors of the liquid lens with the 2x2 sockets on the optics mount.



6. Press the liquid lens onto the imager lens until you reach the stop.



7. Re-attach the illumination module.



8. Re-attach the front cover.



Note: The rib in the front cover must be oriented to the top side.

Note: Observing the tightening sequence below, tighten all four M2 x 12 mm Phillips Pan screws to 16 Ncm using a torque wrench.

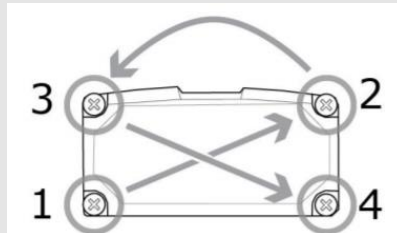

DataMan 300 and 360 Series Service Procedures

Replacing a 10.3 mm Lens

To remove and replace a 10.3 mm lens of a DataMan 300 or 360 series reader, perform the following steps:

WARNING: Disconnect the DataMan reader from power before continuing.

CAUTION: Do not leave the image sensor exposed to the environment.

Note: The following steps describe service procedures for both the DataMan 300 and the 360 readers, but the images show only the DataMan 360.

1. Remove and retain the four screws at the corners of the front cover.

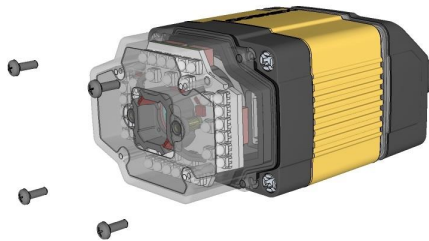

2. Remove the front cover. The first image shows a reader with a liquid lens attached to the 10.3 mm lens. The second image shows a reader with a 10.3 mm lens only.

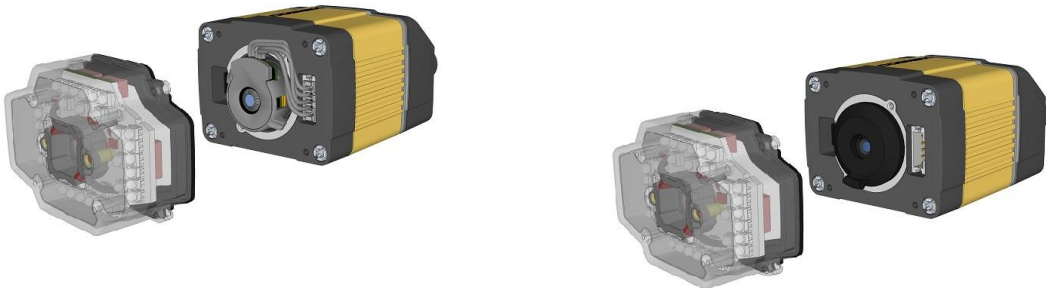

3. If you have a liquid lens module attached to your 10.3 mm lens, carefully disconnect the liquid lens module cable. If you only have a 10.3 mm lens inserted, jump to step 5 of this procedure.

WARNING: Do not pinch or pull the cable.



- Loosen the lens locking ring and withdraw the module.



When reinstalling the module, observe the following precautions:

- Make sure that the liquid lens cable is not pinched, pulled or crimped during installation.

- Loosen the locking ring and withdraw the lens.

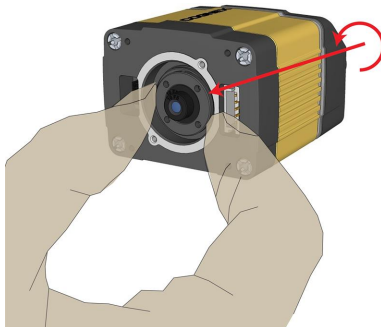

When reattaching the front cover, tighten the screws in the sequence shown below and observe a torque limit of 9 N-cm (0.8 Lb-In).

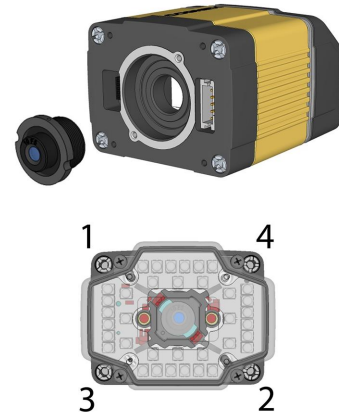

Installing the 24 mm Liquid Lens Module

The possible hardware configurations using a 24 mm liquid lens module with a DataMan 300 or 360 series reader is the following: DM3xx-system + DM300-LENS-24LL + DM360-HPIL-RE-01 / DM360-HPIL-RE-P-01.

To install a 24 mm liquid lens module of a DataMan 300 or 360 series reader, perform the following steps:

WARNING: Disconnect the DataMan reader from power before continuing.

CAUTION: Do not leave the image sensor exposed to the environment.

Note: The following steps describe service procedures for both the DataMan 300 and the 360 readers, but the images show only the DataMan 360.

1. Attach the **24 mm Lens** to the device by using the screw thread on the metal ring.

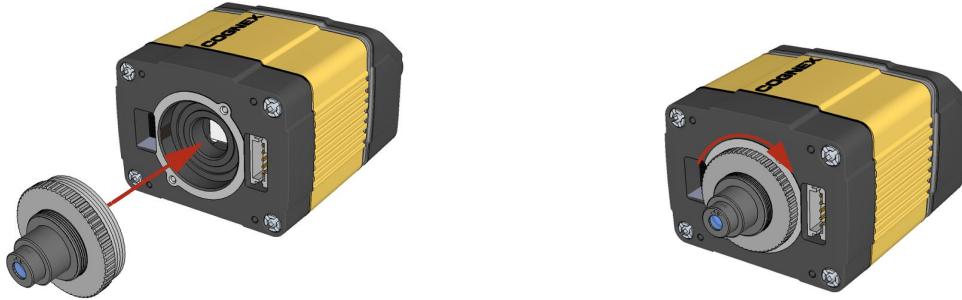

1. Insert the **Liquid Lens cable** into the connector of the device.



2. Attach the **Liquid Lens** to the front side of the **24mm Lens**.



- Place the **DM360-HPIL-RE-01** or **DM360-HPIL-RE-P-01** unit on the front of the device.

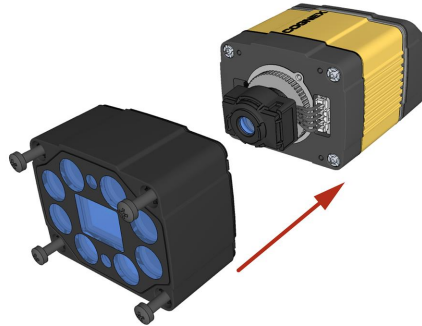

CUSTOMIZED CAPTIVE SCREW, PHILLIPS PAN HEAD, M3x28mm

Note: The minimum peak current capacity of the power supply for the device and the DM360-HPIL-RE-01 / DM360-HPIL-RE-P-01 is 2 A per unit for the DataMan 300 and 2.2 A per unit for the DataMan 360.

Note: The DM360-HPIL-RE-01 or DM360-HPIL-RE-P-01 is also compatible with the 10.3 mm Liquid Lens. For the 10.3 mm Liquid Lens, use CUSTOMIZED CAPTIVE SCREW, PHILLIPS PAN HEAD, M3x28mm.

- Screw in the four screws.

Note: Use 0.2 Nm torque on the screws and tighten in sequence.

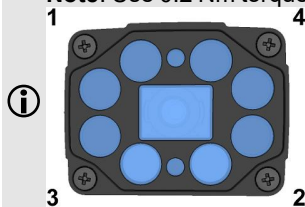

Replacing a 16 mm (SHD) Lens

To remove and replace a 16 mm (SHD) lens of a DataMan 300 or 360 series reader, perform the following steps:

WARNING: Disconnect the DataMan reader from power before continuing.

CAUTION: Do not leave the image sensor exposed to the environment.

Note: The following steps describe service procedures for both the DataMan 300 and the 360 readers, but the images show only the DataMan 360.

1. Remove and retain the four screws at the corners of the front cover.

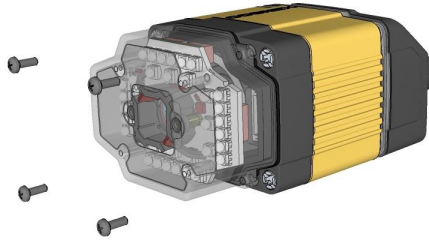

2. Remove the front cover.



3. Remove the rubber lens-locking cone from the lens.

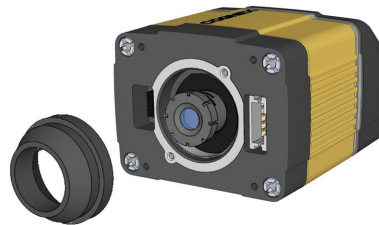

4. Remove the lens.



When replacing the lens, observe the following precaution:

- Avoid rotating the lens when you insert it. Press the rubber lens-locking cone into the reader until it snaps into place inside the C-mount threads and around the nose of the 16 mm lens.

When reattaching the front cover, tighten the screws in the sequence shown and observe a torque limit of 9 N-cm (0.8 Lb-In).

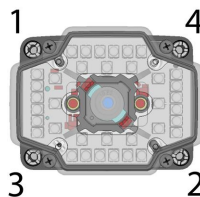

Replacing a C-Mount Lens

To remove and replace a C-Mount lens of a DataMan 300 or 360 series reader, perform the following steps:

⚠ WARNING: Disconnect the DataMan reader from power before continuing.

⚠ CAUTION: Do not leave the image sensor exposed to the environment.

i Note: The following steps describe service procedures for both the DataMan 300 and the 360 readers, but the images show only the DataMan 360.

1. Remove the front cover.



i Note: Do not unscrew the front-most part of the nose of the cover to avoid risking the glass lens falling out.

2. Remove the screws from the C-mount cover base.



3. Remove the C-Mount cover base.



4. Remove the lens.



When replacing the lens, observe the following precaution:

- When you attach the front cover, align the peg on the reader and the slot on the cover so that the cover locks in place.

When reattaching the C-mount cover base, tighten the screws in the sequence shown and observe a torque limit of 9 N-cm (0.8 Lb-In).

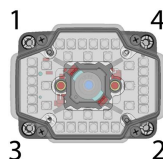

DataMan 370 and 470 Series Service Procedures

You can choose between a variety of different (High Speed) Liquid Lenses and C-Mount lens options to be installed on your DataMan 370 or 470 series reader.

Assembly		Instructions
DataMan 374 + HPIL		Installing the Liquid Lens Module with High Power Integrated Light (HPIL) on page 58
DataMan 474 + HPIL		
DataMan 37x + HPIA		Installing a Lens with High Power Illumination Accessory (HPIA) on page 62
DataMan 47x + HPIA		
DataMan 37x + HPIT		Installing High Power Integrated Torch (HPIT) on page 64
DataMan 47x + HPIT		
DataMan 37x + C-Mount		Installing a C-Mount Lens on page 66
DataMan 47x + C-Mount		

The following sections describe service procedures for both the DataMan 370 and the 470 series readers, but the images show only the DataMan 370.

Installing the Liquid Lens Module with High Power Integrated Light (HPIL)

For possible hardware configurations using a liquid lens module with HPIL for DataMan 374 or 474, see the *DataMan 370 Series Reference Manual* and the *DataMan 470 Series Reference Manual*, respectively.

Tools needed:

- Wrench for lens locking ring (10.3 mm LL only - delivered by Cognex with Liquid Lens module)
- Phillips screwdriver

To install a 10.3 mm or a 24 mm liquid lens module of a DataMan 374 or 474 reader, perform the following steps:

⚠ WARNING: Disconnect the DataMan reader from power before continuing.

⚠ CAUTION: Do not leave the image sensor exposed to the environment.

i Note: The following steps describe service procedures for both the DataMan 374 and the 474 readers, but the images show only the DataMan 374.

1. Remove the adhesive protective film covering the threaded lens opening.

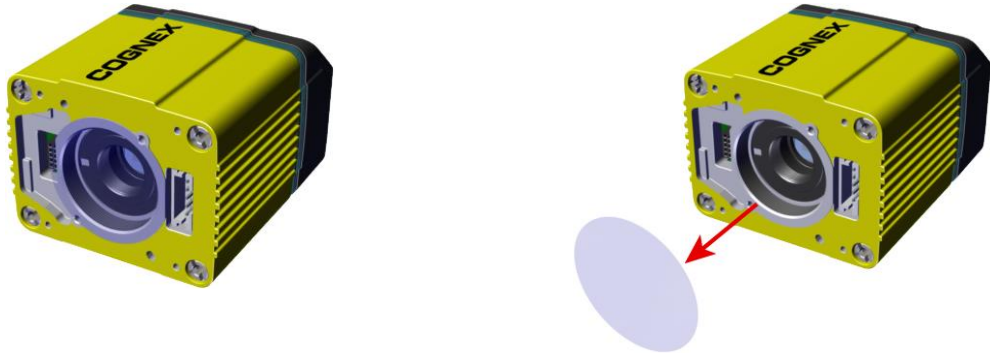

2. Attach the **24 mm Lens** to the device by using the screw thread on the metal ring.

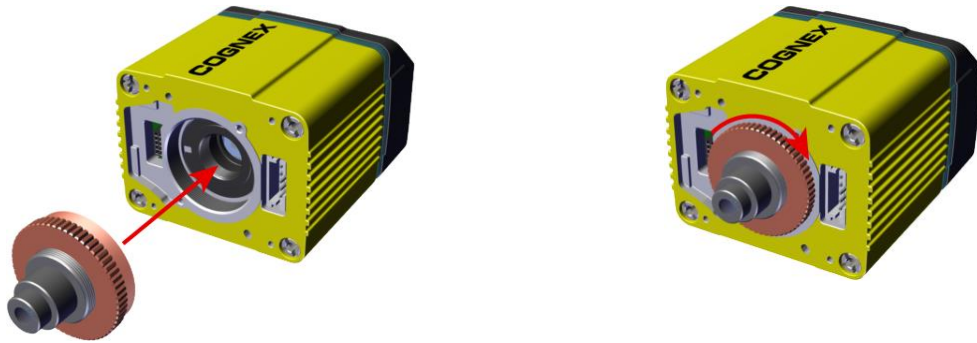

Insert an S-Mount adapter, thread the **10.3 mm Lens** into the reader, and tighten the locking ring.

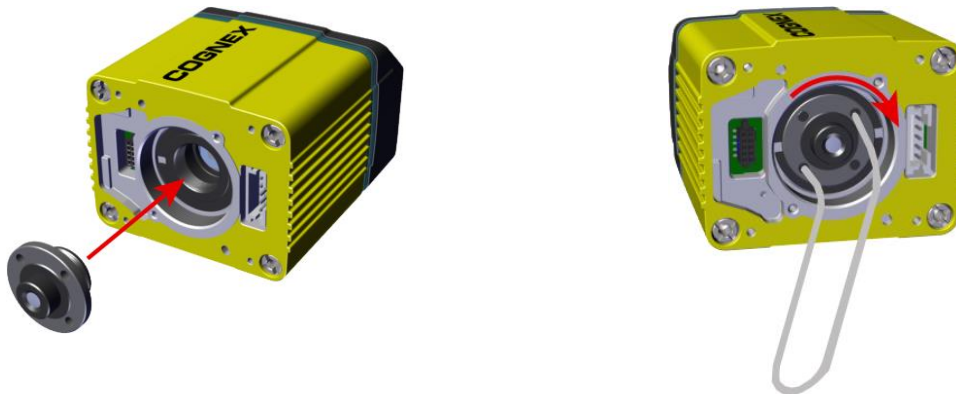

3. Insert the **Liquid Lens cable** into the connector of the reader.

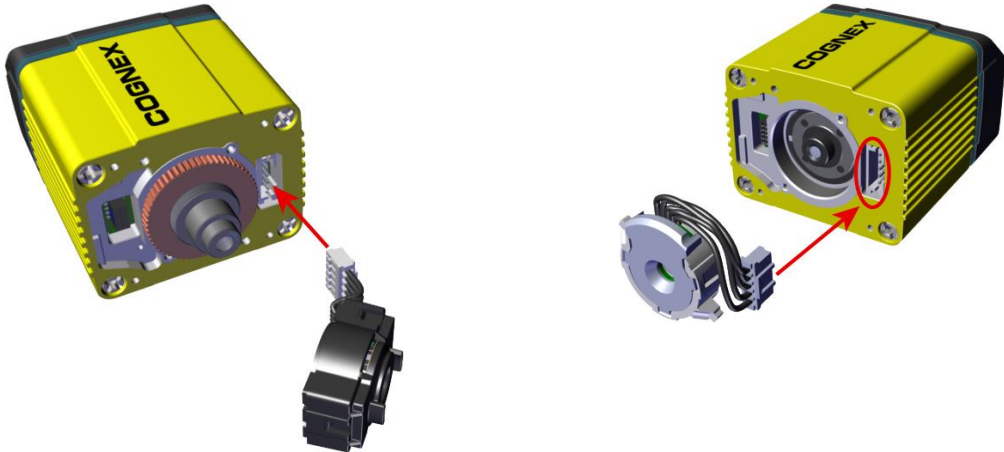

⚠ WARNING: To avoid equipment damage, the cables must be routed as shown in the figure.

4. Attach the **Liquid Lens** to the front side of the **24 mm Lens**.



In case of the **10.3 mm Lens**, attach the liquid lens module onto the nose of the lens.



- Place the **HPIL** unit on the front of the device.

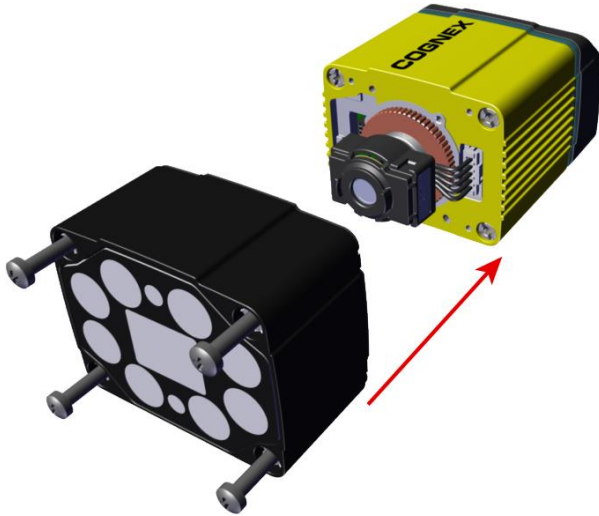

CUSTOMIZED CAPTIVE SCREW, PHILLIPS PAN HEAD, M3x28 mm

- Screw in the four screws.

Note: Use 0.2 Nm torque on the screws and tighten in sequence.

Replacing a 10.3 mm Lens

To remove and replace a 10.3 mm lens of a DataMan 370 or 470 series reader, perform the following steps:

WARNING: Disconnect the DataMan reader from power before continuing.

CAUTION: Do not leave the image sensor exposed to the environment.

Note: The following steps describe service procedures for both the DataMan 370 and the 470 series readers, but the images show only the DataMan 470.

- If you have a liquid lens module attached to your 10.3 mm lens, carefully disconnect the liquid lens module cable. If you only have a 10.3 mm lens inserted, jump to step 3 of this procedure.

WARNING: Do not pinch or pull the cable.



- Loosen the lens locking ring and withdraw the module.

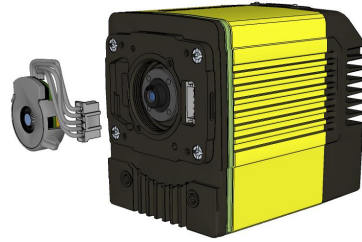

When reinstalling the module, observe the following precautions:

- Make sure that the liquid lens cable is not pinched, pulled or crimped during installation.

- Loosen the locking ring and withdraw the lens.

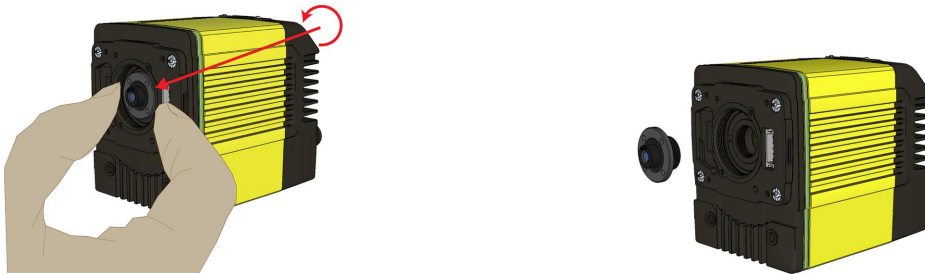

Installing a Lens with High Power Illumination Accessory (HPIA)

For a list of lenses compatible with the HPIA, see the *DataMan 370 Series Reference Manual* and the *DataMan 470 Series Reference Manual*, respectively.

Tools needed:

- Wrench for lens locking ring (10.3 mm LL only - delivered by Cognex with Liquid Lens module)
- Phillips screwdriver (PH0)
- Phillips screwdriver (PH1)

Note: The following steps describe service procedures for both the DataMan 370 and the 470 series readers, but the images show only the DataMan 370.

To install a lens module of a DataMan 370 or 470 reader with HPIA, perform the following steps:

- To install the **lens**, see:
 - [Installing a C-Mount Lens on page 66](#)
 - [Installing the Liquid Lens Module with High Power Integrated Light \(HPIL\) on page 58](#)
 - [Installing High Power Integrated Torch \(HPIT\) on page 64](#)

- Place the **HPIA** on the front of the reader.



- Insert the **lens cover mounting plate** into the HPIA and secure them to the reader using the four M3 screws.

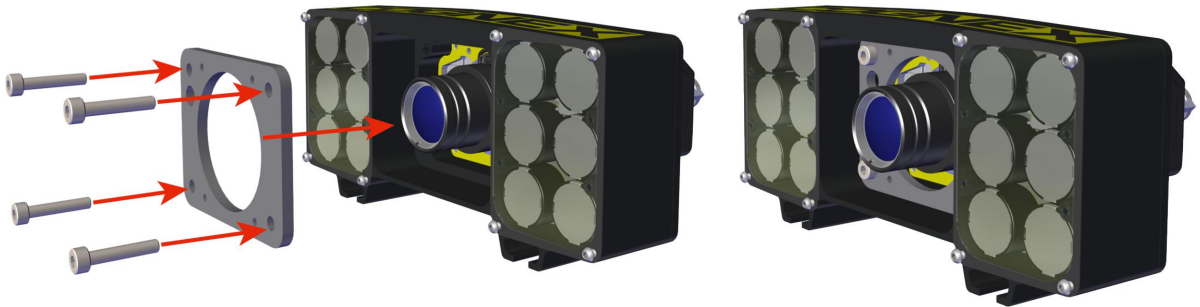

M3 x 16 mm screws

Note: Use a 3 mm hex wrench to torque the screws to 0.34 Nm (3 in-lb). Tighten in sequence.

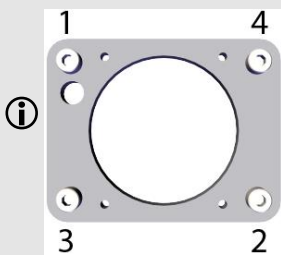

- Attach the **C-mount lens cover** to the front of the plate and secure it using the four M2 screws.

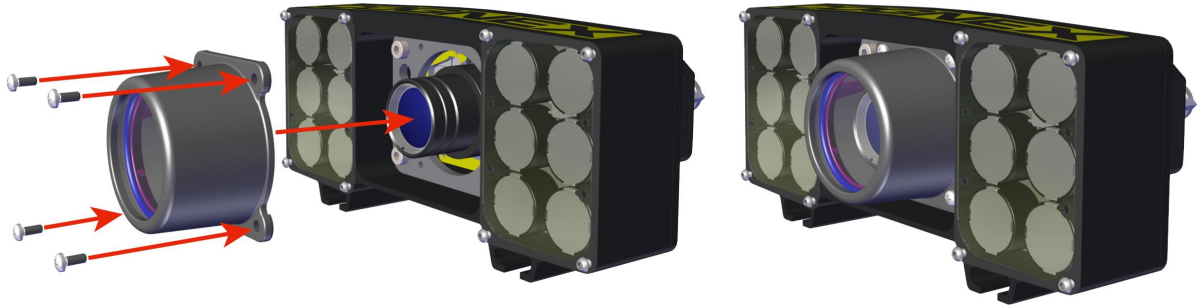

Note: For lenses that do not fit under the DM500-CMTLC-000 lens cover, you are required to use the DM500-LNSEXT-000 lens cover extension.

M2 x 5 mm screws

Note: Use a Phillips Screwdriver (PH0) to torque the screws to 0.09 Nm (0.8 in-lb). Tighten in sequence.

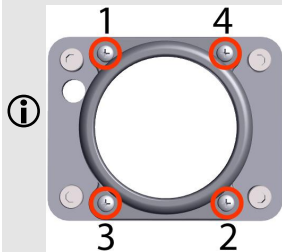

Installing High Power Integrated Torch (HPIT)

For possible hardware configurations using HPIT with a DataMan 370 or 470 series reader, see the *DataMan 370 Series Reference Manual* and the *DataMan 470 Series Reference Manual*, respectively.

Tools needed:

- 2 mm Allen wrench
- Phillips screwdriver (PH0)

Note: The following steps describe service procedures for both the DataMan 370 and the 470 series readers, but the images show only the DataMan 370.

Perform the following steps to mount the HPIT to your DataMan 370 or 470 series reader:

- Remove the adhesive protective film covering the threaded lens opening.

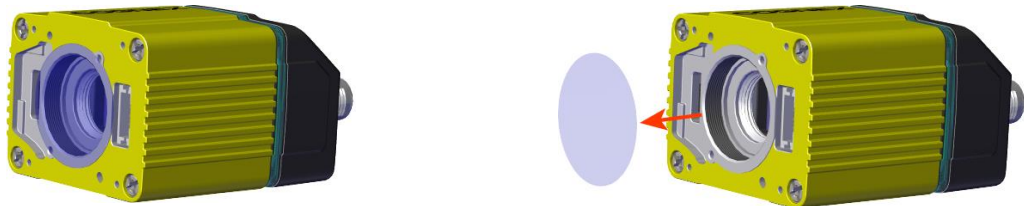

- Add the small PCB into the light connector.



3. Attach the DM470 HPIT adapter plate.



M3 x 6 mm screws

Note: Use a 2 mm hex wrench to torque the screws to 0.34 Nm (3 in-lb). Tighten in sequence.

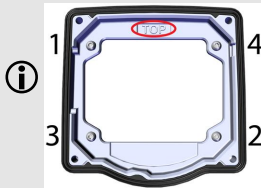

4. Attach the lens module and fix the lens with the captive screws.

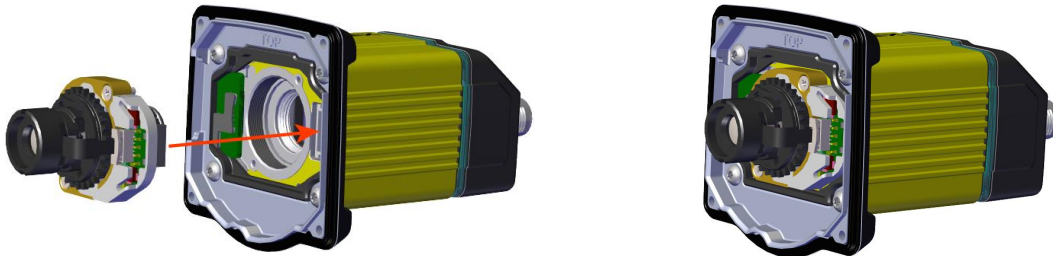

Note: Use a Phillips screwdriver (PH0) to torque the screws to 0,08 Nm (0.7 in-lb). Tighten in sequence.

- Do not push or pull the lens at its barrel – push or pull on the metal housing.
- Be careful not to touch the gear ring with the screwdriver.

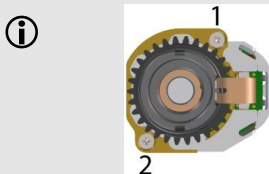

5. Attach the light module.

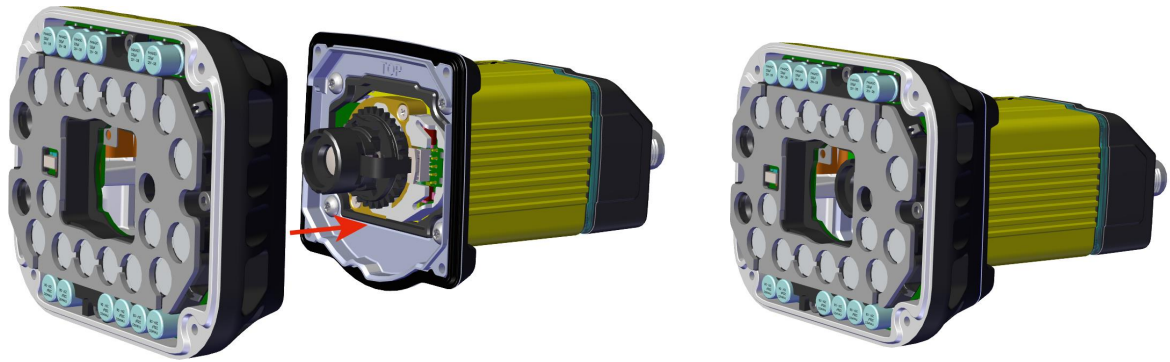

M3 x 6.35 mm captive screws

Note: Use a 2 mm hex wrench to torque the captive screws to 0.34 Nm (3 in-lb). Tighten in sequence.

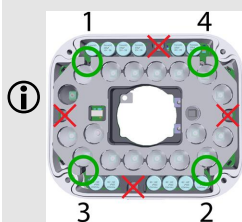

6. Attach the front cover.

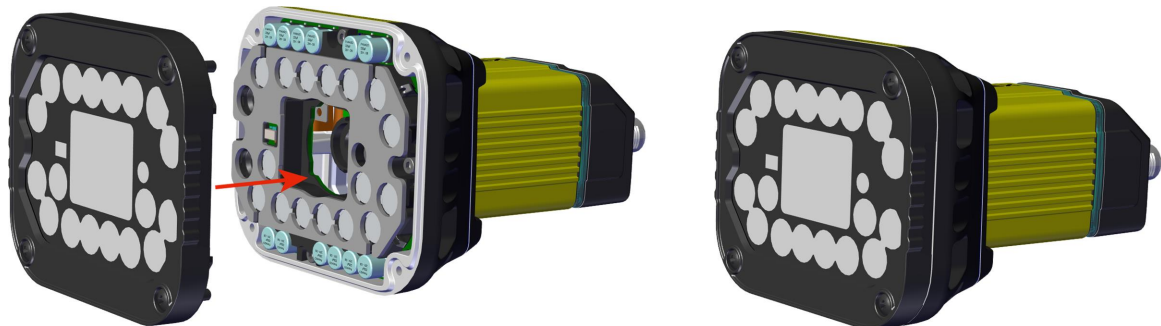

M3 x 12mm captive screws

Note: Use a Phillips Screwdriver (PH0) to torque the captive screws to 0.31 Nm (2.75 in-lb). Tighten in sequence.

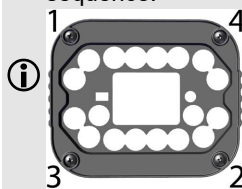

Note: Remove the adhesive protective film from the front cover after attaching it.

Installing a C-Mount Lens

Note: The following steps describe service procedures for both the DataMan 370 and the 470 series readers, but the images show only the DataMan 370.

Possible hardware configurations using a C-Mount lens with a DataMan 370 or 470 series reader:

System	Lens	Lens Part Number	C-Mount Cover (DM300-CMCOV)	Short C-Mount Cover (DM300-CMCOV-SH)
DM370 DM470	12 mm F8	LEC-CFF12-F8	✓	✓
	16 mm F8	LEC-CFF16-F8	✓	
	25 mm F8	LEC-CFF25-F8	✓	✓
	35 mm F8	LEC-CFF35-F8	✓	
	40 mm F8	LEC-CFF40-F8	✓	
	50 mm F8	LEC-CFF50-F8	✓	

1. Remove the adhesive protective film.

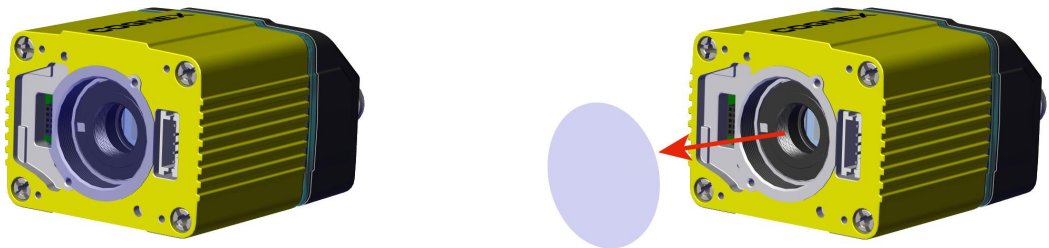

2. Thread the lens into the reader.

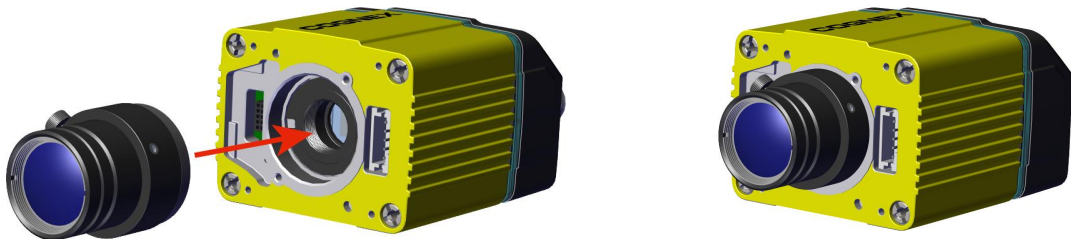

3. Place the reader at the desired working distance from focus target.

Note: Make sure to set focus for the reader before fitting the lens cover.

- a. Connect the reader to the DataMan Setup Tool.
- b. Navigate to the **Optimize Image** pane, and on the **Basic** tab, click the triangle on the **Live** button to access the drop-down list, and check the **Focus Feedback** option.
- c. Use the DataMan Focus Target template, available through the Windows **Start** menu or the DataMan Setup Tool **Help** menu, to align the edge of the reader body to the line marked with the target distance used in your application.

- d. Adjust focus for maximum sharpness. Enhance image quality in the DataMan Setup Tool for better guidance.

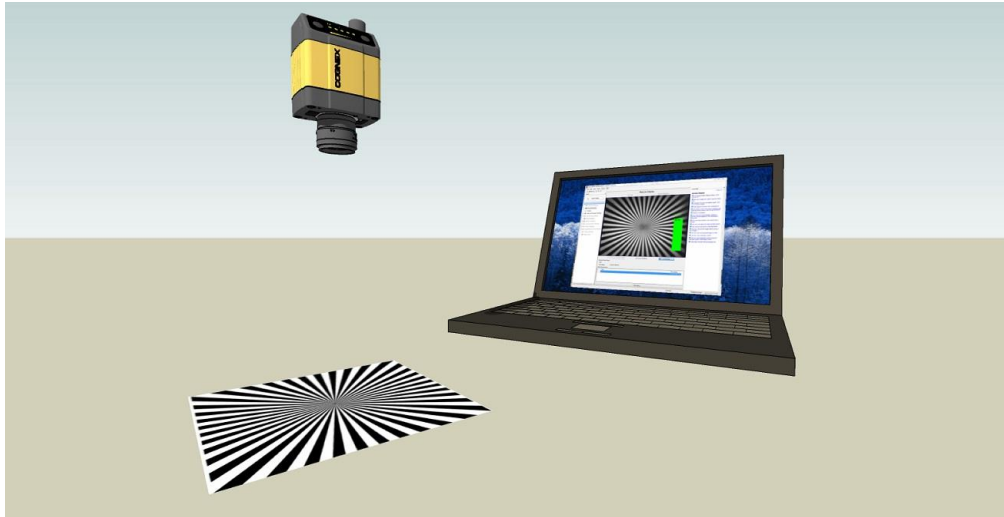

4. Attach the C-Mount cover base.

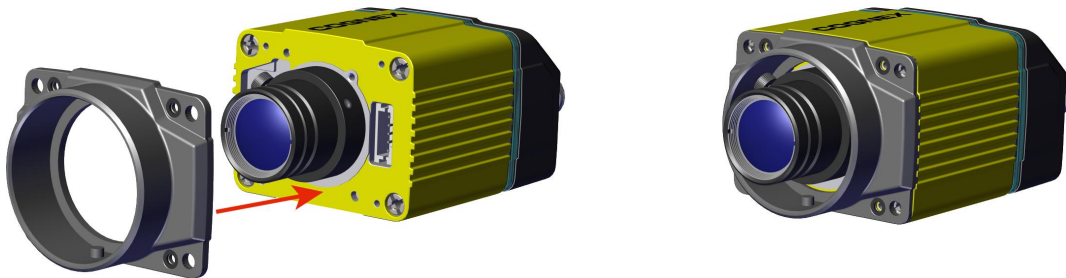

5. Add the screws to the C-Mount cover base.

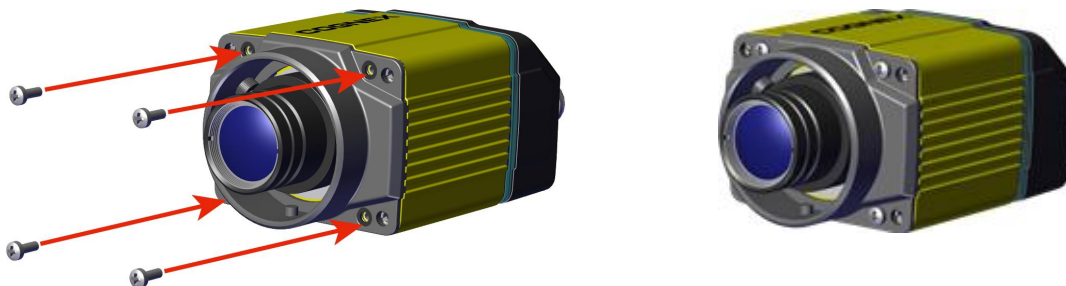

PHILLIPS PAN HEAD M2 X 6 mm

Note:
Tighten in sequence. Torque limit: 9 Ncm (0.8 in-lbs).

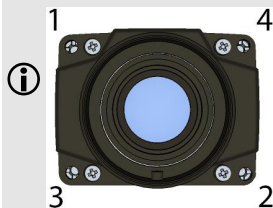

6. Attach the front cover.

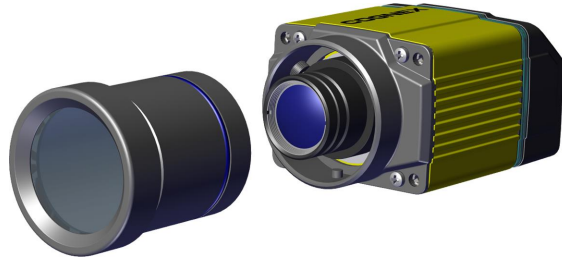

Note: Do not unscrew the front-most part of the nose of the cover to avoid risking the glass lens falling out.

7. Align the peg on the reader and the slot on the cover so that the cover locks in place.

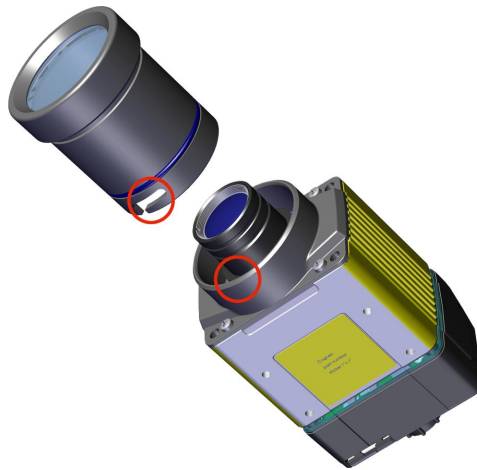

Replacing a C-Mount Lens

To remove and replace a C-Mount lens of a DataMan 370 or 470 series reader, perform the following steps:

WARNING: Disconnect the DataMan reader from power before continuing.

CAUTION: Do not leave the image sensor exposed to the environment.

Note: The following steps describe service procedures for both the DataMan 370 and the 470 series readers, but the images show only the DataMan 470.

1. Remove the front cover.



Note: Do not unscrew the front-most part of the nose of the cover to avoid risking the glass lens falling out.

2. Remove the screws from the C-mount cover base.

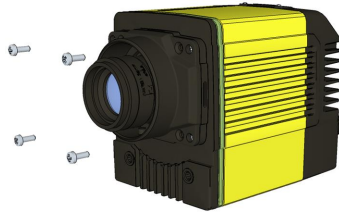

3. Remove the C-Mount cover base.



4. Remove the lens.



When replacing the lens, observe the following precaution:

- When you attach the front cover, align the peg on the reader and the slot on the cover so that the cover locks in place.

DataMan 503 Service Procedures

Installing a C-Mount Lens

DataMan 503 ships with no lens installed. You must install a standard C-mount lens before using your reader.

For reading distances and field of view charts, see the *DataMan Fixed-Mount Reference*, available through the Windows **Start** menu or the DataMan Setup Tool **Help** menu.

1. Remove the front cover, if attached, and lens cover.

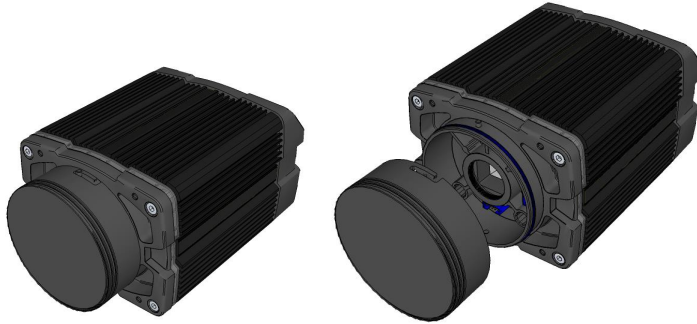

Note: Remove the protective cover from the lens mount.

CAUTION: Do not leave the DataMan sensor exposed to the environment!

2. Insert and thread lens into the reader.

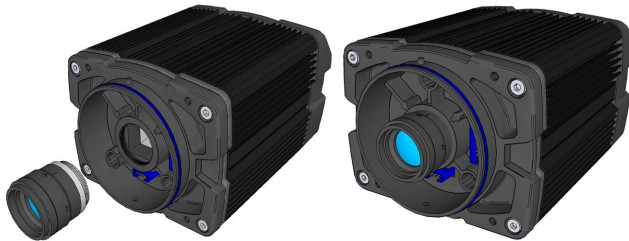

3. Align the peg on the reader and the slot on the cover, and re-attach it.



4. Lock the cover in place.



Maintenance

Replacing the SD Card

The DataMan 370 and 470 series readers are equipped with a Micro SD card slot and an SD card is pre-installed for saving backup and configuration files. In the unlikely event when a reader breaks down and needs to be replaced, complete the following steps to clone the reader by replacing the SD card.

Note: The reader supports SD cards with a maximum capacity of 8 GB, formatted with a FAT32 file system.

CAUTION:



- Hot-plugging the SD card is not supported and may damage the SD card and/or lead to unexpected behavior. The SD card has to be present already at the boot phase. Do not pull out the SD card during operation.
- Observe ESD precautions when installing or removing an SD card or other accessories.

1. Disconnect the reader from the power source.
2. Unscrew the screw(s) in the Micro SD card cover to open the card slot.
3. Remove the existing SD card from the Micro SD card slot.
4. Insert the SD card from the broken reader into the Micro SD card slot to clone the old reader. Ensure the card is properly oriented.

5. Replace the SD card cover and reinsert the screw(s).

Note: Torque the screw(s) to 0.18 Nm (25 in-oz). Tighten in sequence.

DataMan 370



DataMan 470



6. Restore power to the reader.

Mounting Requirements

The DataMan 150, 260, 300, 360, 370, 470, and 503 series readers provide four threaded attachment points, located as shown in the previous sections:

- [DataMan 70 Series Reader Dimensions](#)
- [DataMan 150 Series Reader Dimensions](#)
- [DataMan 260 Series Reader Dimensions](#)
- [DataMan 280 Series Reader Dimensions](#)
- [DataMan 300 Series Reader Dimensions](#)
- [DataMan 360 Series Reader Dimensions](#)
- [DataMan 370 Series Reader Dimensions](#)
- [DataMan 470 Series Reader Dimensions](#)
- [DataMan 503 Reader Dimensions](#)

The attachment points have the following characteristics:

- M3 thread
- 5 mm thread depth
- 9 N-cm (0.8 Lb-In) maximum torque

 **CAUTION:** Use all four attachment points when mounting your DataMan reader.

Mounting the DataMan 70 Reader

Mounting the DataMan 70 at a slight angle (15°) can reduce reflections and improve reader performance. Having a recess for screw heads on the top and the bottom, the DataMan 70 allows for upside down mounting. Recommended fasteners and nuts:

- Fastener: 2 x DIN 7985 M3x30 mm or DIN 912/ISO 4762 M3x30 mm
- Nut: 2 x DIN 985 M3

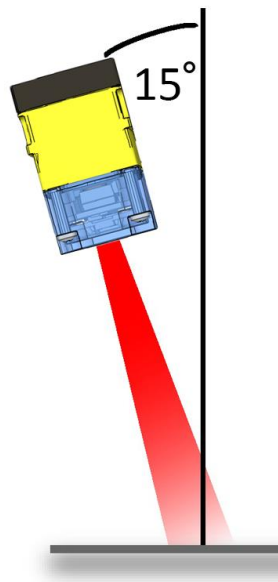
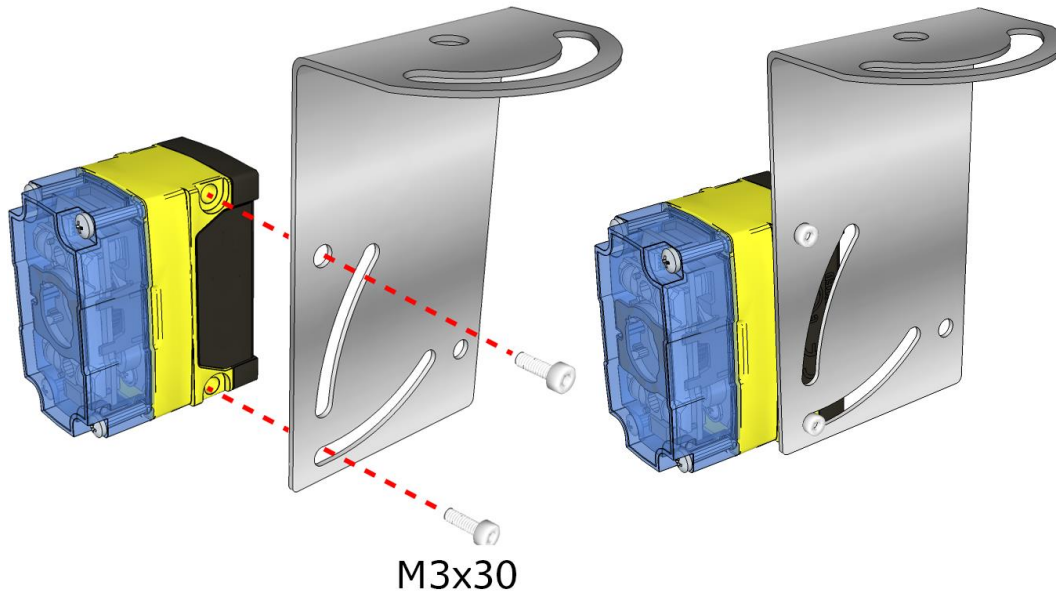

Mounting the DataMan 150 and 260 Reader

Mounting the DataMan 150 and the DataMan 260 at a slight angle (15°) can reduce reflections and improve reader performance.

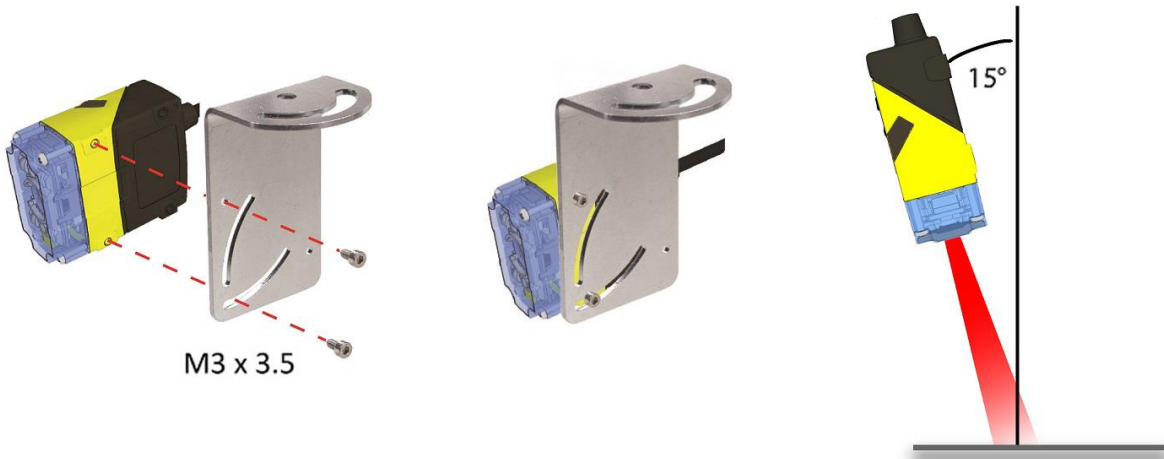

Right-Angle Configuration



Changing Orientation

Perform the following steps to change between in-line and right-angle configuration.

Note:



- Switching between in-line and right-angle configuration is recommended only up to 10 times in the lifetime of your DataMan device.
- Disconnect the DataMan device from power before changing the orientation.



WARNING: Make sure that no electrostatic charges are applied to the PCB. (For example, wear ESD shoes.) If the main module is separated from the I/O connector module, take care to assemble them correctly. Otherwise, the IP rating can be compromised.

- Carefully remove the screw covers, threaded nuts and washers.

DataMan 150

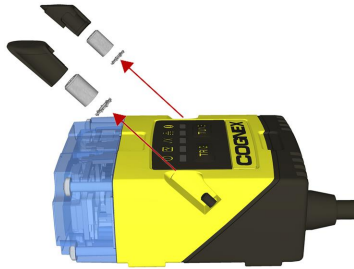

DataMan 260

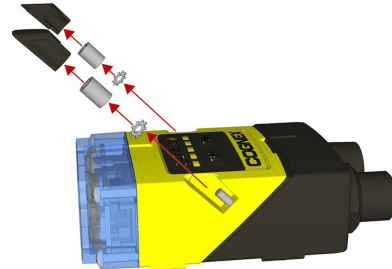

M2 Torx 10 CAP NUT

DIN 6798A M2 LOCKWASHER

- Detach the main module and the I/O connector module by firmly pulling them apart.

DataMan 150

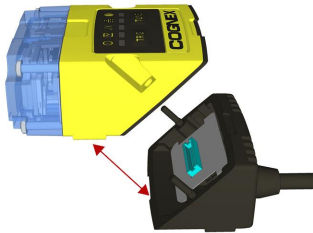

DataMan 260

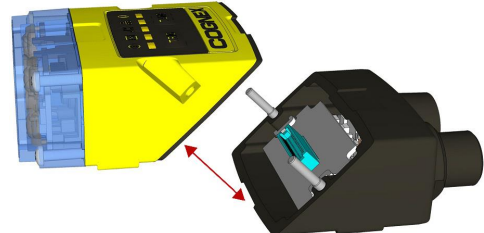

- Change the orientation.

Note: Make sure that the gasket is properly seated on the main module. Ensure that the flat gasket side is facing away from the module

DataMan 150

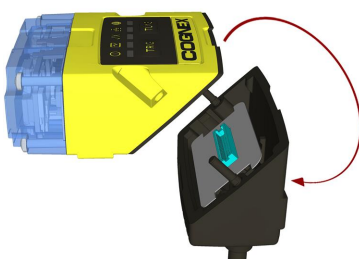

DataMan 260

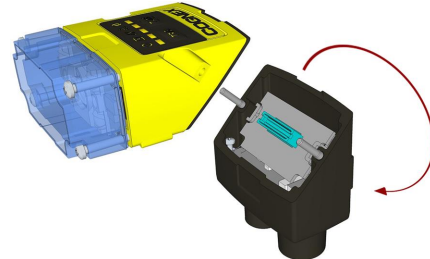

Place the bottom edge of the gasket onto the underside of the main module. Press on the top edge to fully seat the gasket:

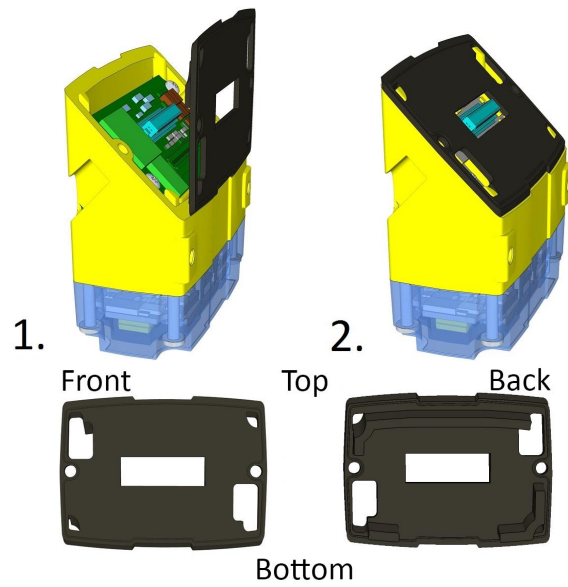

Note: The flat side of the gasket (marked as "Front" in the image above) has to face outside.

WARNING: Do not touch any electrical component.

1. Reattach the I/O connector module to the main module.

DataMan 150



DataMan 260

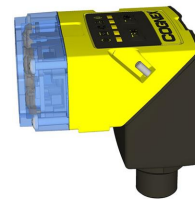

2. Reinstall the washers and loosely fasten the modules together with the two T10 cap nuts, but do not tighten.

DataMan 150

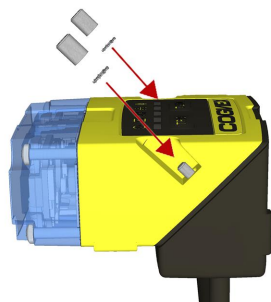

DataMan 260

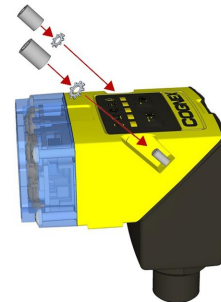

- After each cap nut has been fastened, torque to 0.12 Nm (1.06 in-lb) and reinstall the screw covers.

Note: There are unique left and right screw covers. Take care to attach them correctly.

DataMan 150

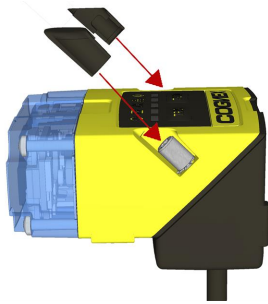

DataMan 260

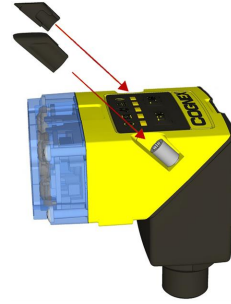

Mounting the DataMan 280 Reader

The reader provides mounting holes for attachment to a mounting surface.

CAUTION: The reader has to be grounded, either by mounting the reader to a fixture that is electrically grounded or by attaching a wire from the reader's mounting fixture to frame ground or Earth ground. If a ground wire is used, it has to be attached to one of the four mounting points on the bottom plate of the reader and not to the mounting points on the front of the reader.

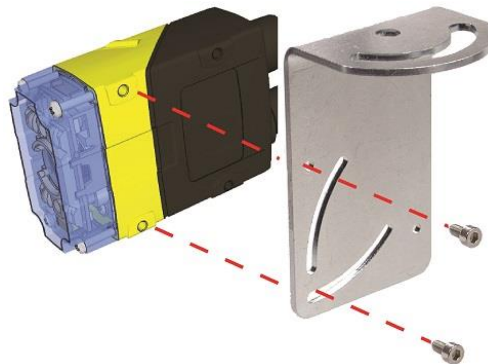

Note:

Mounting the DataMan 280 at a slight angle (15°) reduces reflections and improves performance of the reader.

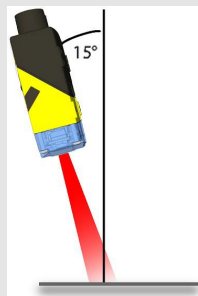

Mounting the DataMan 370 and 470 Reader

The accessory mounting bracket kit (DMBK-370-MNT for the DataMan 370 and DMBK-470-MNT for the DataMan 470) includes the mounting bracket, four Phillips flat head M3 DIN 965 screws for attaching the reader to the mounting bracket and

four M6 DIN 912 (ISO 4762) screws for securing the bracket to a mounting surface.

CAUTION: It is recommended the reader be grounded, either by mounting the reader to a fixture that is electrically grounded or by attaching a wire from the reader's mounting fixture to frame ground or Earth ground. If a ground wire is used, it should be attached to one of the four mounting points on the back plate of the reader; not to the mounting points on the front of the reader.

1. Align the holes on the mounting surface with the mounting holes on the reader.

DataMan 370

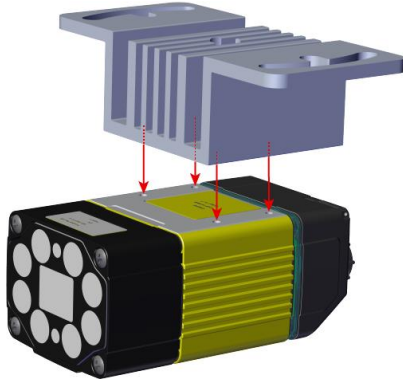

DataMan 470

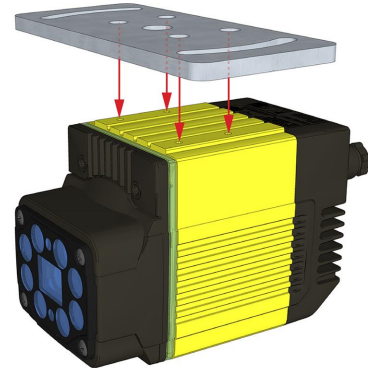

2. Insert the M3x5, DIN 965 (4x) screws into the mounting holes.

Note: Use a 2.5 mm hex wrench to torque the captive screws to 0.60 Nm (5 in-lb). Tighten in sequence.

DataMan 370

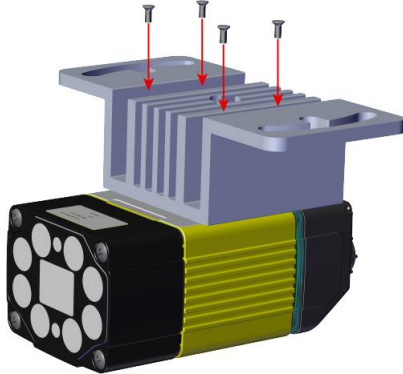

DataMan 470

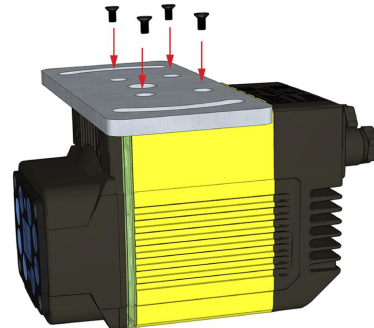

3. Align the mounting holes on the mounting plate with the M6 drop-in nuts and the M6, DIN 912 (ISO 4762) socket head screw in the mounting surface.

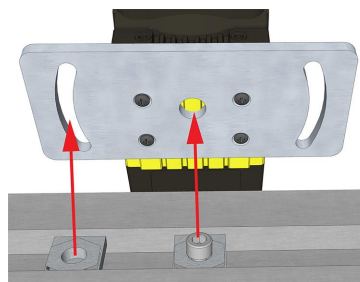

4. Attach the mounting bracket to the mounting surface using M6, DIN 912 (ISO 4762) socket head screws with M6 drop-in nuts for OTS aluminum profiles.

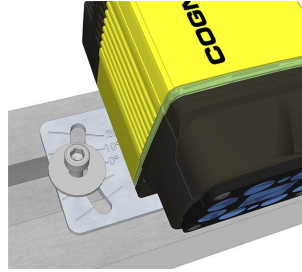

Mounting the DataMan reader at a slight angle (15°) can reduce reflections and improve performance.

DataMan 370

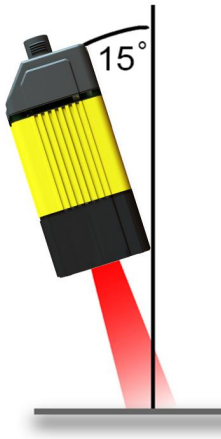

DataMan 470

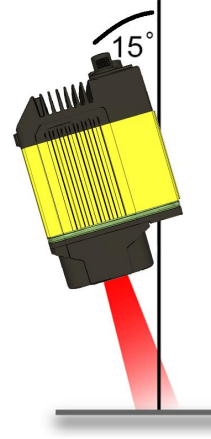

Grounding

If you want to mount a DataMan fixed-mount reader to a bracket or a plate, make sure that those parts make a proper connection to ground (PE). Cognex recommends that you use lock-washers between the mounting screws and the bracket to ensure permanent ground conductivity.

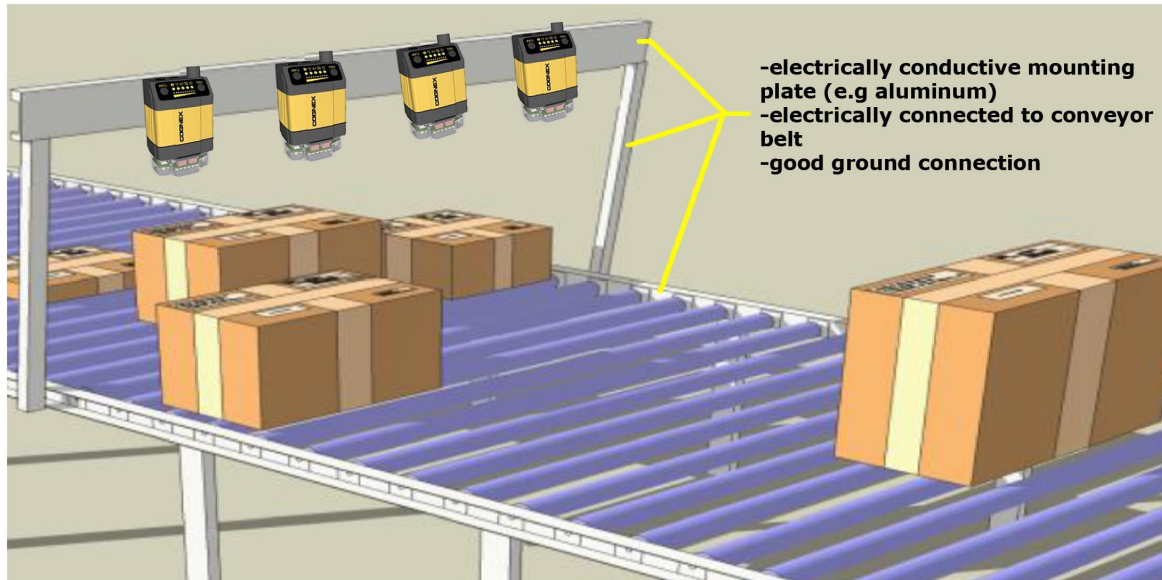

If you want to mount your reader to an electrically isolated bracket, the reader needs to be individually grounded.

For this purpose, Cognex recommends that you connect at least one of the 4 mounting holes on the bottom of the device with a minimum 22 gauge grounding wire to system ground (PE). Use lock-washers to ensure a permanent and robust connection.

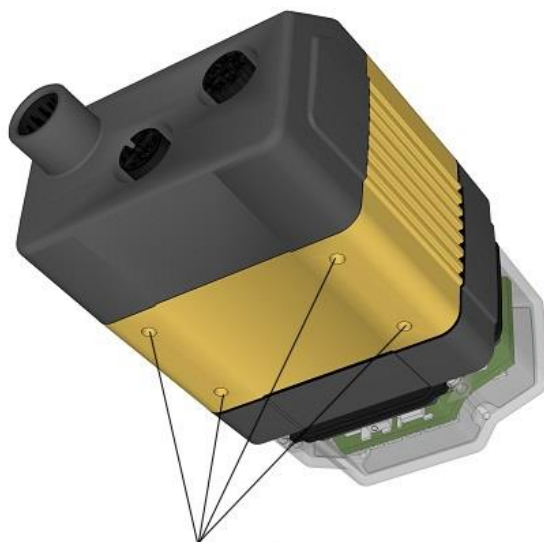

Mounting holes
(M3x5mm)

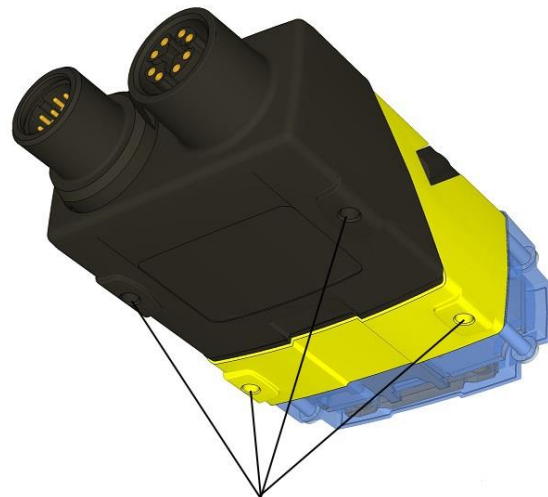

Mounting holes
(M3x3.5mm)

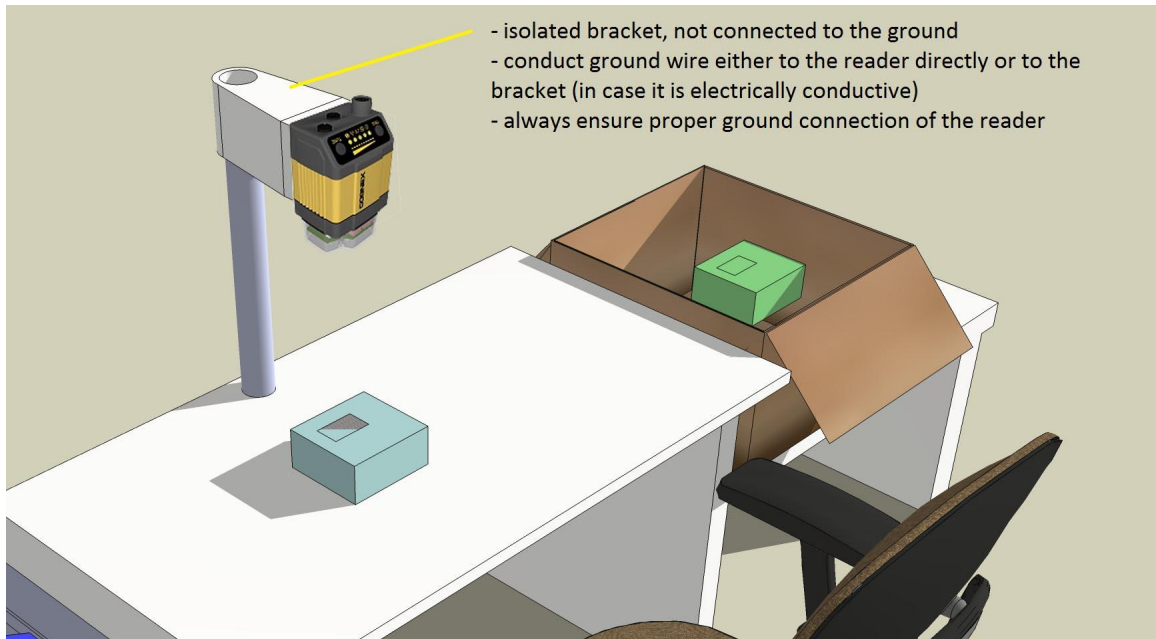

Thermal and Environmental Requirements

See the following table for thermal and environmental requirements:

Operating temperature	0 °C — 40 °C (32 °F — 104 °F)
Storage temperature	-10 °C — 60 °C (-14 °F — 140 °F)
Maximum humidity	95% (non-condensing)

DataMan 50, 150, 260, 300, 360, and 503 IP Rating

The DataMan 50, 150, 260, 300, 360 series and 503 readers provide IP65 protection against dust and water intrusion. In order to meet this rating, the following conditions must be met:

- All connectors must have cables connected or be sealed with protective plugs.
- The reader front cover and lens cover must be correctly installed.
- The requirements for temperature, vibration, and shock must be met.

DataMan 60 and 70 IP Rating

The DataMan 60 and 70 readers provide IP40 protection against dust and water intrusion. In order to meet this rating, the following conditions must be met:

- All connectors must have cables connected or be sealed with protective plugs.
- The reader front cover and lens cover must be correctly installed.
- The requirements for temperature, vibration, and shock must be met.

DataMan 280, 370 and 470 IP Rating

The DataMan 280, 370 and 470 series readers provide IP67 protection against dust and water intrusion. In order to meet this rating, the following conditions must be met:

- All connectors must have cables connected or be sealed with protective plugs.
- The reader front cover and lens cover must be correctly installed.
- The requirements for temperature, vibration, and shock must be met.

Electrical Information

DataMan 50 and 60 Discrete I/O Connector

The I/O cable provides access to trigger and high-speed outputs. Unused wires can be clipped short or tied back using a tie made of non-conductive material. For RS-232, use the Power Supply return path for ground.

Note: GND (Pin 4) is connected to the reader housing, cable shield, and DB15 shell.

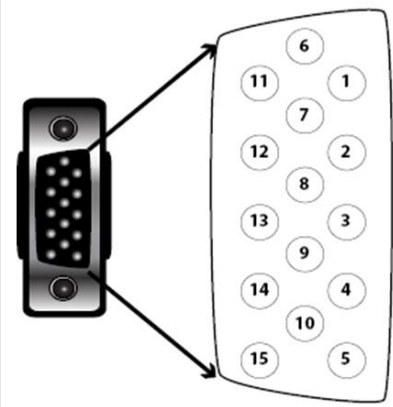
	PIN	Color	Signal
 <p>This is a male connector/plug.</p>	1	Brown	Reserved
	2	Green	TxD
	3	Green/Black	RxD
	4	Red and Brown/White	GND
	5	Red/Black	DC+ (system power, 5-24 VDC)
	6	Blue	RTS
	7	Blue/White	Output-0
	8	White	Input-0
	9	White/Black	Input-1
	10	Light Blue	CTS
	11	Light Blue/Black	Output-1
	12	Light Blue/Yellow	Output-Common
	13	Light Blue/Green	Output-Strobe
	14	Yellow	Reserved
	15	Yellow/Black	Reserved

DataMan 50 and 60 USB & Flying Leads I/O Cable

You can connect a cable with USB & flying leads (DM-USBIO-00) to the cable that is attached to the device. The following table shows the pinout and color description of the flying leads.

	PIN	Color	Signal
 <p>This is a female socket/connector.</p>	4	Black	GND
	7	Blue/White	Output-0
	8	White	Input-0
	9	White/Black	Input-1
	11	Light Blue/Black	Output-1
	12	Light Blue/Yellow	Output-Common
	13	Light Blue/Green	Output-Strobe

DataMan 50 and 60 RS-232 & Flying Leads I/O Cable

You can connect a cable with RS-232 & flying leads (DM-RS232IO-00) to the cable that is attached to the device. The following table shows the pinout and color description of the flying leads.

 <p>This is a female socket/connector.</p>	PIN	Color	Signal
	4	Black	GND
	5	Brown/White	VDC
	7	Blue/White	Output-0
	8	White	Input-0
	9	White/Black	Input-1
	11	Light Blue/Black	Output-1
	12	Light Blue/Yellow	Output-Common
	13	Light Blue/Green	Output-Strobe

DataMan 50 and 60 Flying Leads Cable

You can connect a cable with flying leads (DM50-PWRIO-05) to the cable that is attached to the device. The following table shows the pinout and color description of the flying leads.

 <p>This is a female connector/socket.</p>	IN	Color	Signal
	2	Green	TxD
	3	Green/Black	RxD
	4	Red	GND
	5	Brown/White	DC+ (system power, 5-24 VDC)
	6	Blue	RTS
	7	Blue/White	Output-0
	8	White	Input-0
	9	White/Black	Input-1
	10	Light Blue	CTS

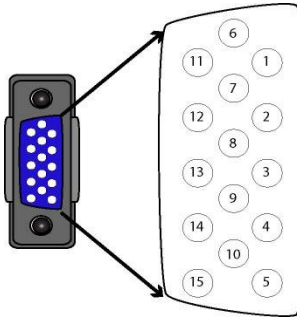

This is a female connector/socket.

IN	Color	Signal
11	Light Blue/Black	Output-1
12	Light Blue/Yellow	Output-Common
13	Light Blue/Green	Output-Strobe

DataMan 50 and 60 Digital Input Lines

Inputs are not galvanic isolated but need to be referenced to ground.

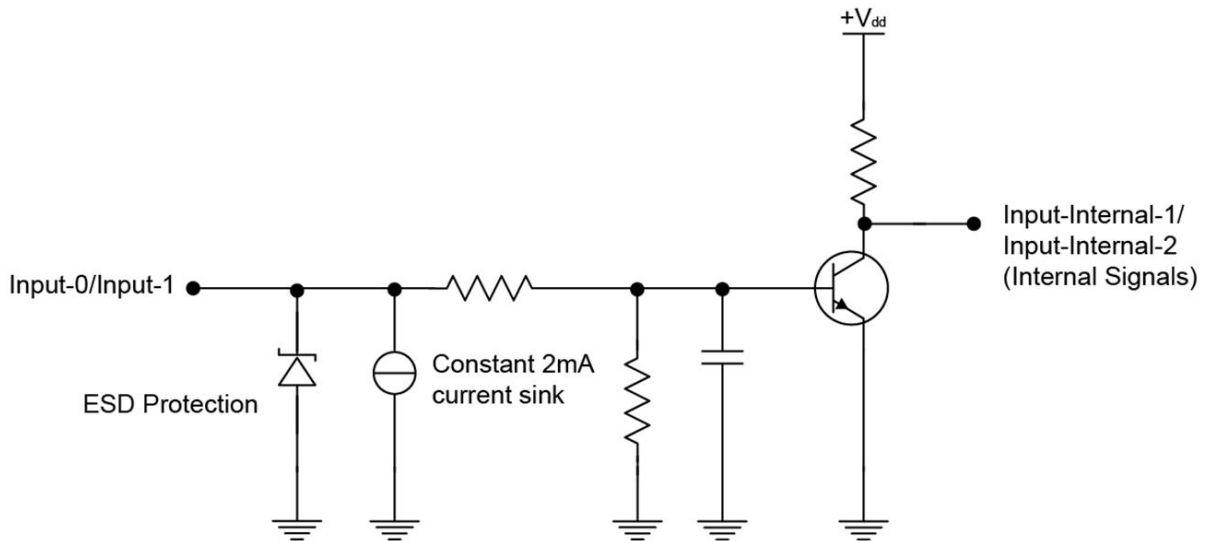

DataMan 50 and 60 External Wiring Examples: Digital Input Lines

The following figures show external wiring examples for digital input lines for the DataMan 50. The DataMan 60 has the same characteristics.

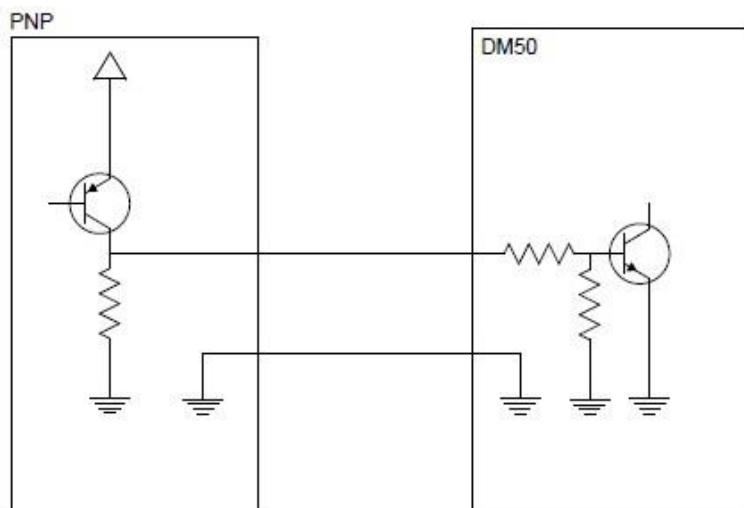
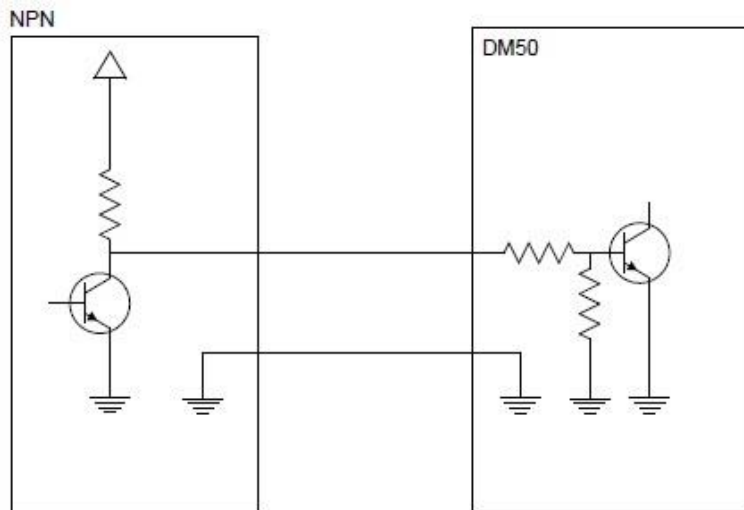
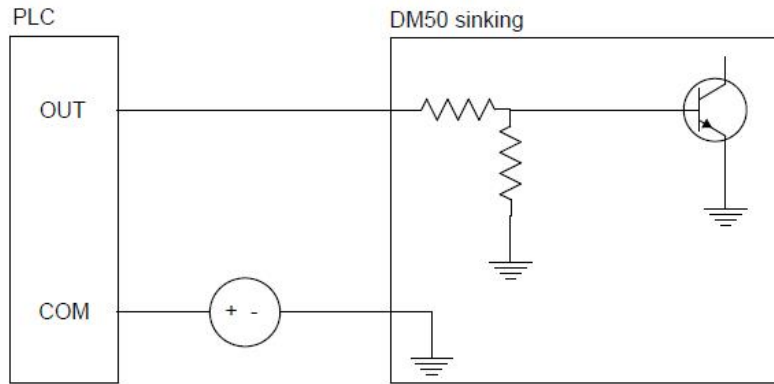

DataMan 50 and 60 Digital Output Lines

The digital outputs can be used as either NPN (pull-down) or PNP (pull-up) lines. For NPN lines, the external load should be connected between the output and the positive supply voltage (<26 V). The outputs pull down to less than 3 V when ON, which causes current to flow through the load. When the outputs are OFF, no current flows through the load. Outputs are not galvanic isolated but need to be referenced to ground.

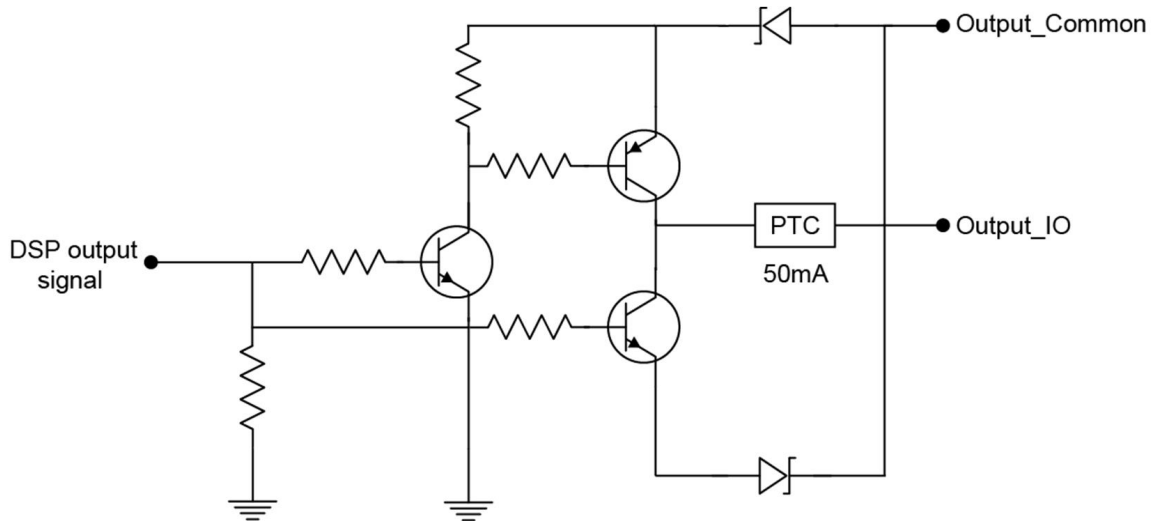

NPN (pull down) output type characteristics	
Applied voltage	26 VDC or less
Residual voltage	0.85 V or less
Maximum sink current	25 mA
Short-circuit current	100 mA or less
Short-circuit protection	multifuse – 50 mA

PNP (pull up) output type characteristics	
Applied voltage	26 VDC or less
Residual voltage	0.8 V or less
Maximum sink current	25 mA
Short-circuit current	50 mA or less
Short-circuit protection	multifuse – 50 mA

Note: For information about the Illumination Strobe Output, see [DataMan 50 and 60 Illumination Strobe Output on page 152](#)

DataMan 50 and 60 External Wiring Examples: Digital Output Lines

The following figures show external wiring examples for digital input lines for the DataMan 50. The DataMan 60 has the same characteristics.

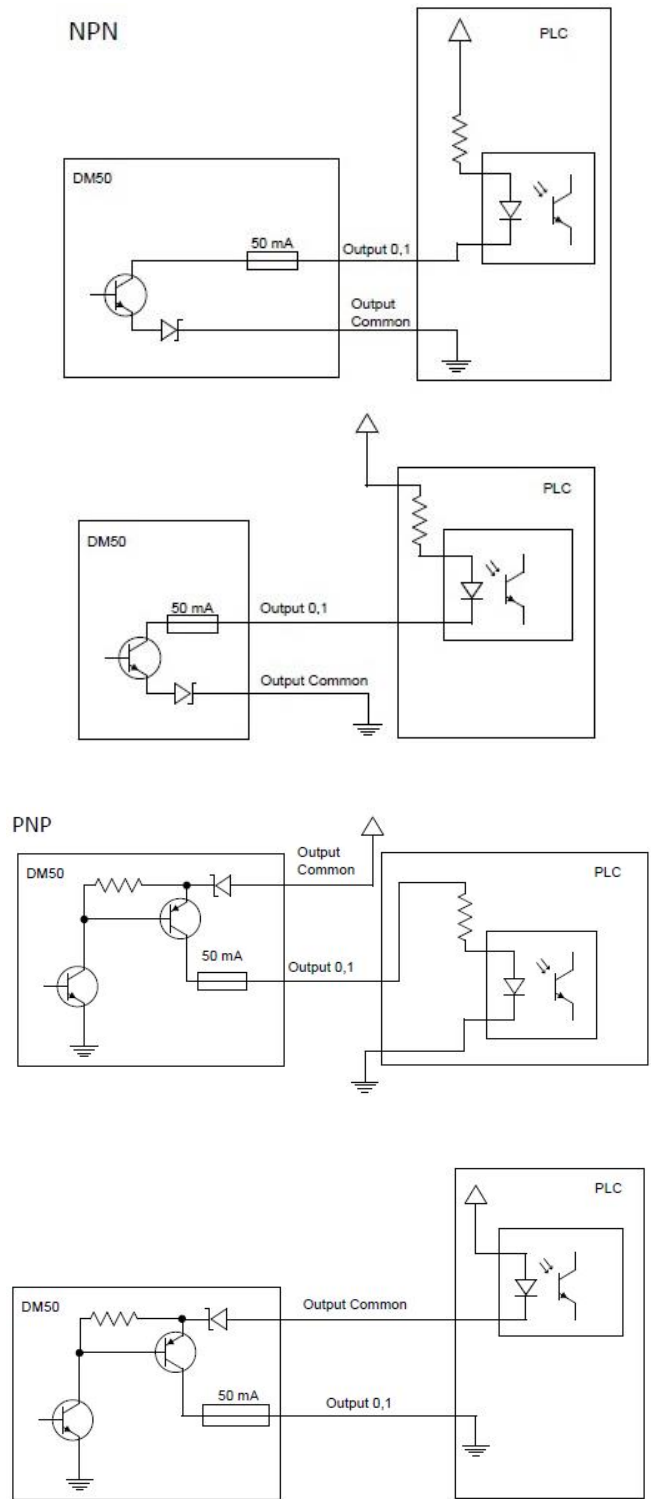

DataMan 70 15 Pin Adapter Cable

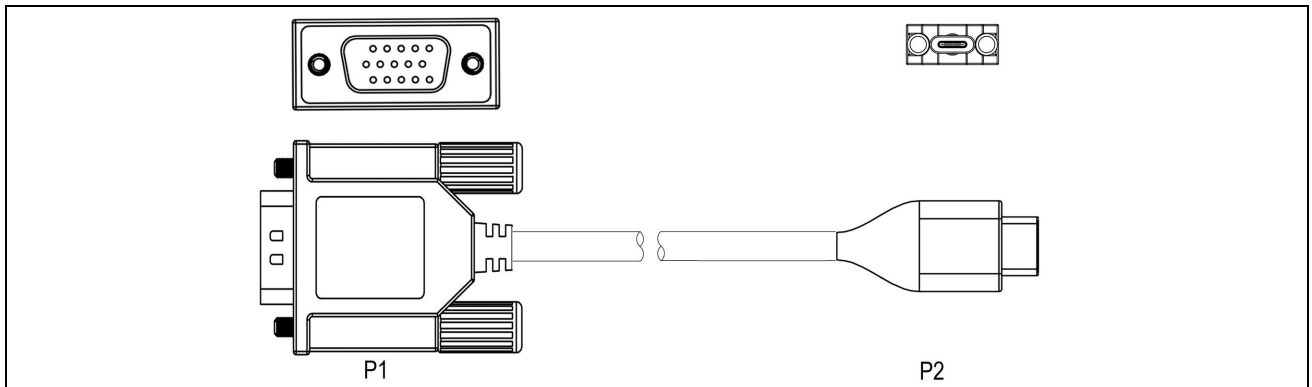

P1 Pin Number	Signal Name
1	Reserved
2	Reserved
3	Reserved
4	Reserved
5	Reserved
6	Ground
7	TXD
8	RXD
9	Reserved
10	Reserved
11	Adapter Power
12	CTS
13	RTS
14	External Trigger
15	External Illumination

DataMan 70 9 Pin Adapter Cable

The following table shows the pinouts.

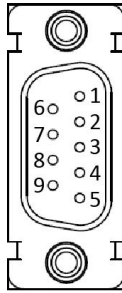

Pin Number	Signal Name
1	Trigger
2	TXD Output TTL Only
3	RXD Input TTL Only
4	NC
5	Ground
6	+5 V Power
7	CTS Input TTL Only
8	RTS Output TTL Only
9	Beeper/Download

DataMan 70 Serial IO Adapter (DMA-SERIALREST-ST)

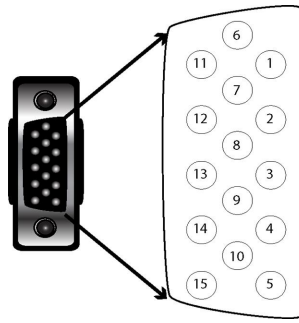

This is a male connector/plug.

Pin Number	Signal Name
1	Reserved
2	TxD
3	RxD
4	GND
5	DC+ (system power, 5-24 VDC)
6	NC
7	Output-0
8	Input-0
9	NC
10	NC
11	NC
12	Output-Common
13	NC
14	Reserved
15	Reserved

DataMan 150 USB Cable

The DataMan 150 is available with USB and RS-232 communication options.

The I/O module with USB has all signals on a SUB-D 15 connector with the following pinouts:

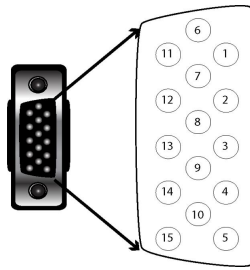

PIN	Color	Signal
1	Brown	Reserved
2	Green	TxD (RS-232)
3	Green/Black	RxD (RS-232)
4	Red & Red/Black	GND
5	Brown/White	DC+ (system power, 5-24 VDC)
6	Blue	RTS
7	Blue/White	Output-0
8	White	Input-0
9	White/Black	Input-1
10	Light Blue	CTS
11	Light Blue/Black	Output-1
12	Light Blue/Yellow	Output-Common
13	Light Blue/Green	Input-Common
14	Yellow	Reserved
15	Yellow/Black	Reserved

Note: Pin numbers are shown for cable connector, not I/O module.

DataMan 70 and 150 Discrete I/O Connector

You can connect a cable with USB & flying leads (DM-USBIO-00) to the cable that is attached to the device. The following table shows the pinout and color description of the flying leads.

Note: GND (Pin 4) is connected to the reader housing, cable shield, and DB15 shell.

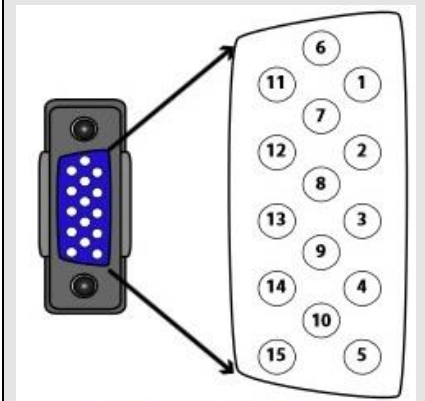
 <p>This is a female socket/connector.</p>	PIN	Color	Signal
	4	Black	GND
	7	Blue/White	Output-0
	8	White	Input-0
	9	White/Black	Input-1
	11	Light Blue/Black	Output-1
	12	Light Blue/Yellow	Output-Common
	13	Light Blue/Green	Input-Common

DataMan 70 and 150 RS-232 Cable

You can connect a cable with RS-232 & flying leads (DM-RS232IO-00) to the cable that is attached to the device. The following table shows the pinout and color description of the flying leads.

 <p>This is a female socket/connector.</p>	PIN	Color	Signal
	4	Black	GND
	5	Brown/White	VDC
	7	Blue/White	Output-0
	8	White	Input-0
	9	White/Black	Input-1
	11	Light Blue/Black	Output-1
	12	Light Blue/Yellow	Output-Common
	13	Light Blue/Green	Input-Common

DataMan 150 Flying Leads Cable

You can connect a cable with flying leads (DM50-PWRIO-05) to the cable that is attached to the device. The following table shows the pinout and color description of the flying leads.

PIN	Color	Signal
2	Green	TxD
3	Green/Black	RxD
4	Red	GND
5	Brown/White	DC+ (system power, 5-24 VDC)
6	Blue	RTS
7	Blue/White	Output-0
8	White	Input-0
9	White/Black	Input-1
10	Light Blue	CTS
11	Light Blue/Black	Output-1
12	Light Blue/Yellow	Output-Common
13	Light Blue/Green	Input-Common

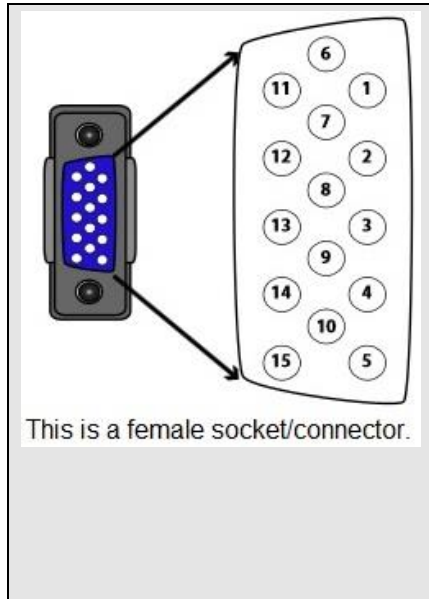

DataMan 150 USB Connections

When connected to a PC over USB, the DataMan 150 appears as a COM port.

You can connect your device to the computer in the following ways:

Connect directly to the PC:

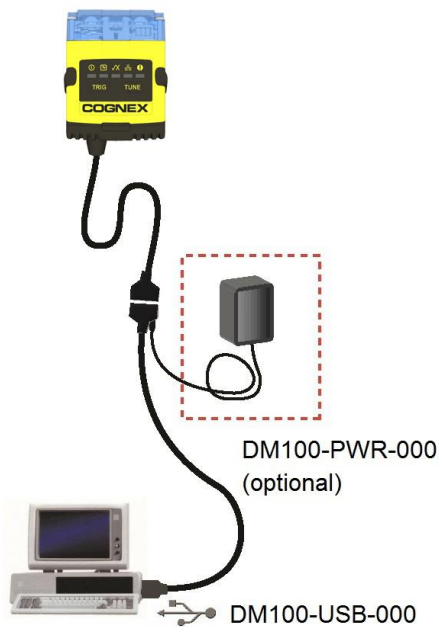

Connect to the PC through a basic I/O module:

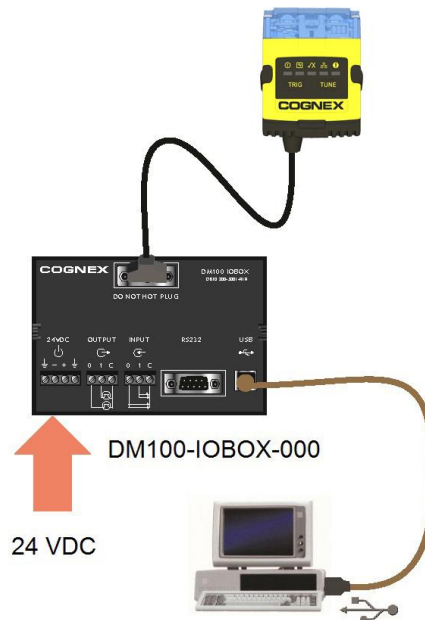

If the reader is configured as an HID device and you want to return to USB serial, scan the USB serial connection code:



Note: The DataMan PC software must be installed for this connection type.

DataMan 150 RS-232 Connections

You can connect the DataMan 150 reader to a PC or other device over a standard RS-232 serial connection.

Note: You must supply external power to use this connection type.

You can make a connection in the following ways:

Connect directly to the PC:

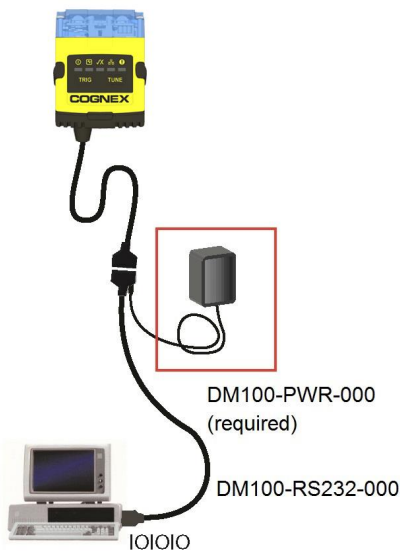

Connect to the PC through a basic I/O module:

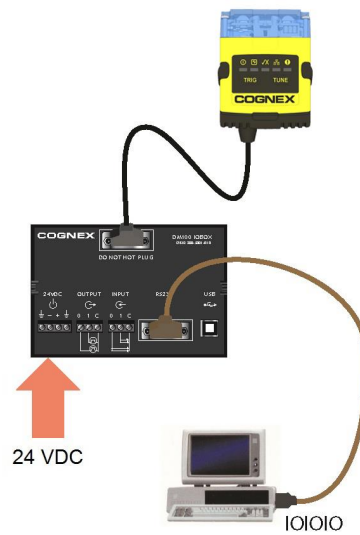

DataMan 150 Wiring the Basic I/O Module

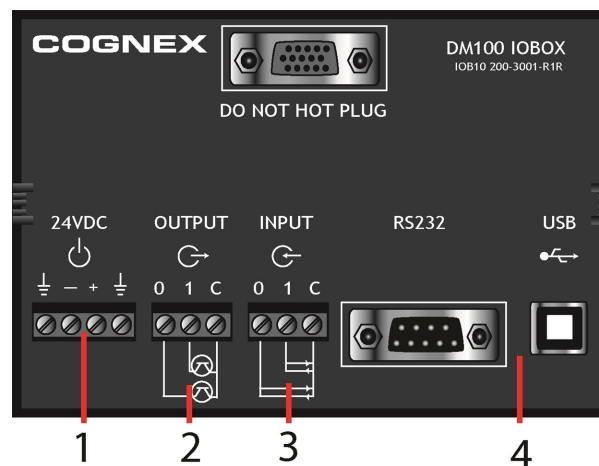

1. **Power:** 5-24 VDC, 2.5 W peak. Connect either ground pin to chassis ground.
2. **Discrete output:** Opto-isolated, current source or sink, depending on wiring; must connect logical ground to common. Outputs are opto-isolated and protected against reverse polarity. Max current is 50 mA @ 24 VDC. Output 1 is used for external illumination control by default.
3. **Trigger input:** Opto-isolated, polarity-independent, current source or sink; have reference to a separated common signal. Work with ± 15 -30 V. Input 0 is dedicated trigger line.
4. **Communication:** RS-232 serial port and USB port.

Note: You must use a null modem cable when connecting the Basic I/O Module to a PC's RS-232 serial port.

Output Wiring Example

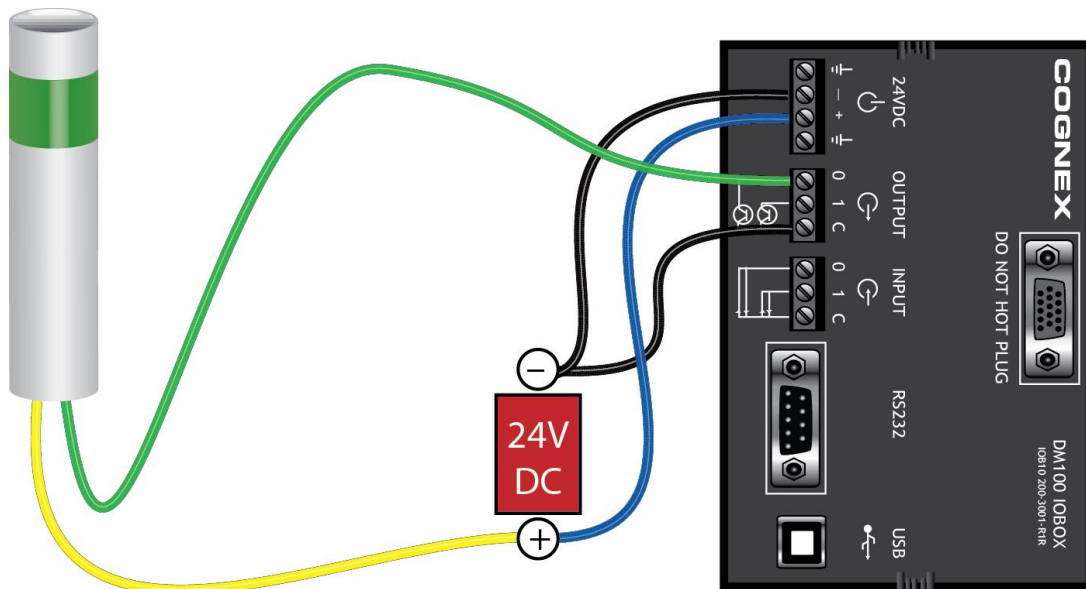

Input Wiring Example

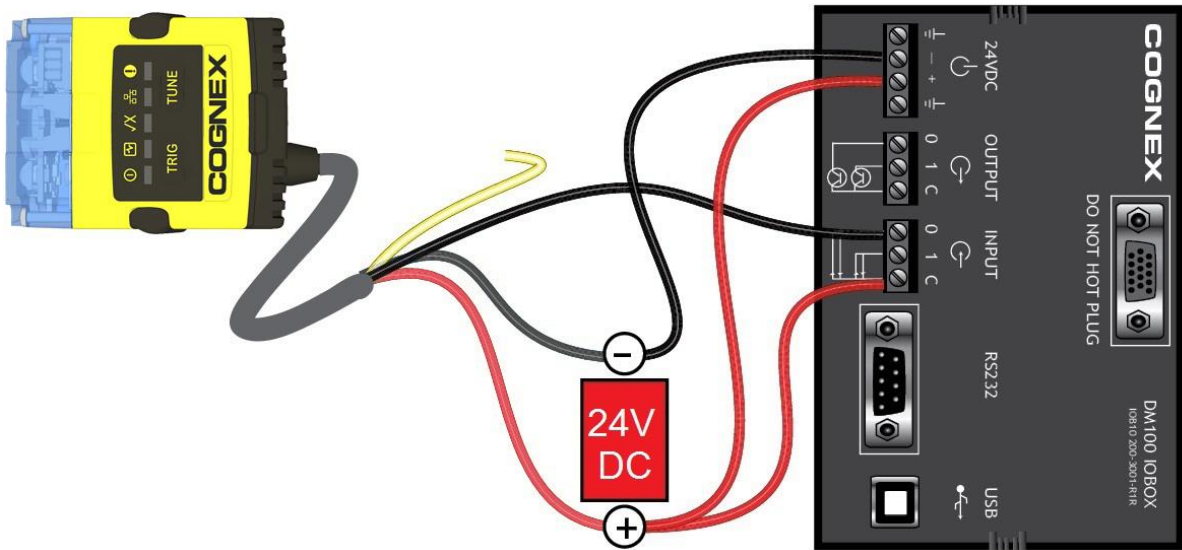

DataMan 150 Digital Input Wiring Diagrams

Current Sink Configuration

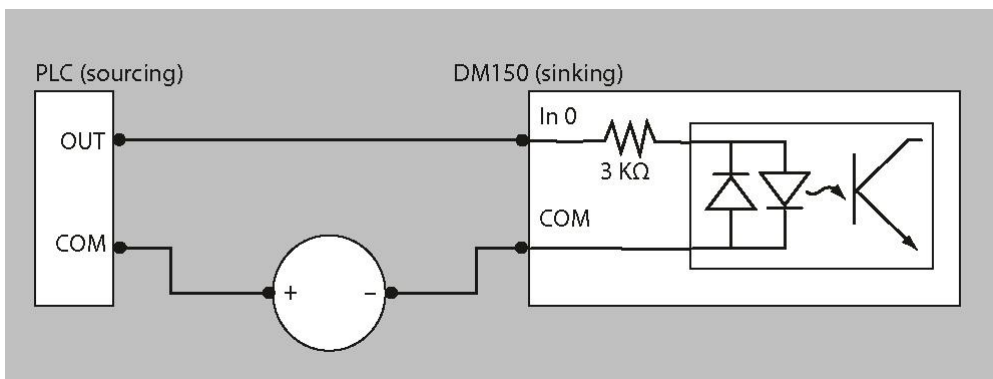

Current Source Configuration

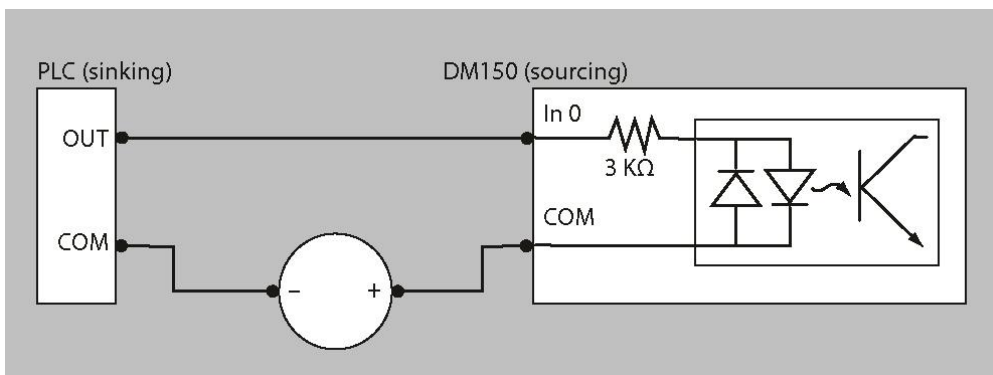

PNP Configuration

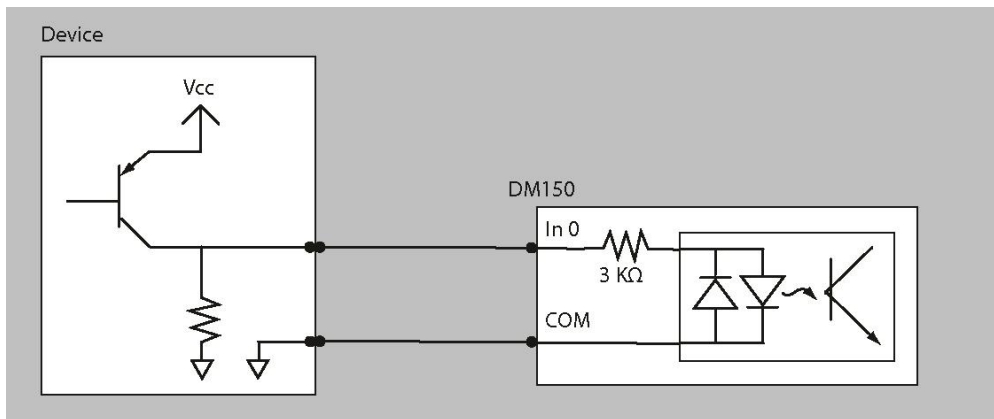

NPN Configuration

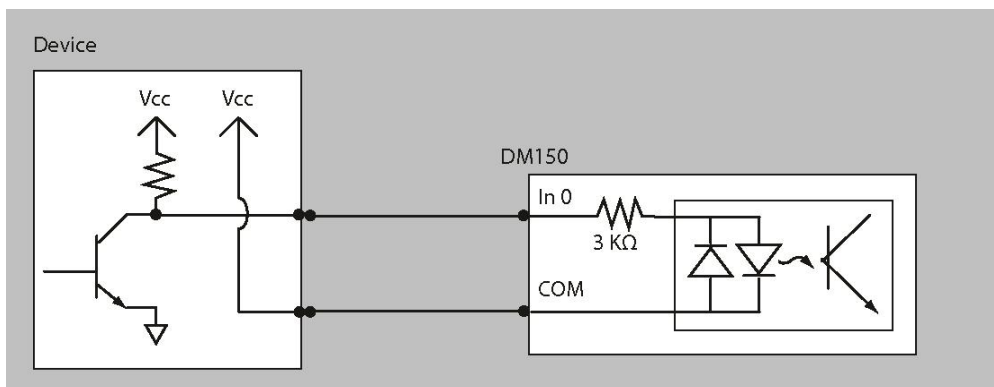

Dataman 150 Digital Output Wiring Diagrams

The digital outputs can be used as either NPN (pull-down) or PNP (pull-up) lines. For NPN lines, the external load should be connected between the output and the positive supply voltage (<26 V). The outputs pull down to less than 3 V when ON, which causes current to flow through the load. When the outputs are OFF, no current flows through the load.

NPN (pull down) output type characteristics are the following:

Applied voltage	26 VDC or less
Residual voltage	0.85 V or less
Maximum sink current	100 mA
Overcurrent protection	multifuse - 160 mA

PNP (pull up) output type characteristics are the following:

Output voltage range	26 VDC or less
Residual voltage	0.85 V or less
Maximum source current	100 mA
Overcurrent protection	multifuse - 160 mA

Sinking Outputs, Sourcing Inputs

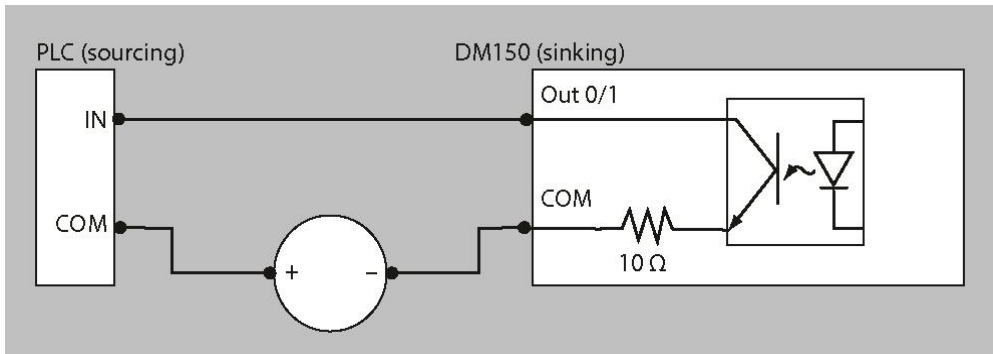

Sinking Outputs, Sinking Inputs

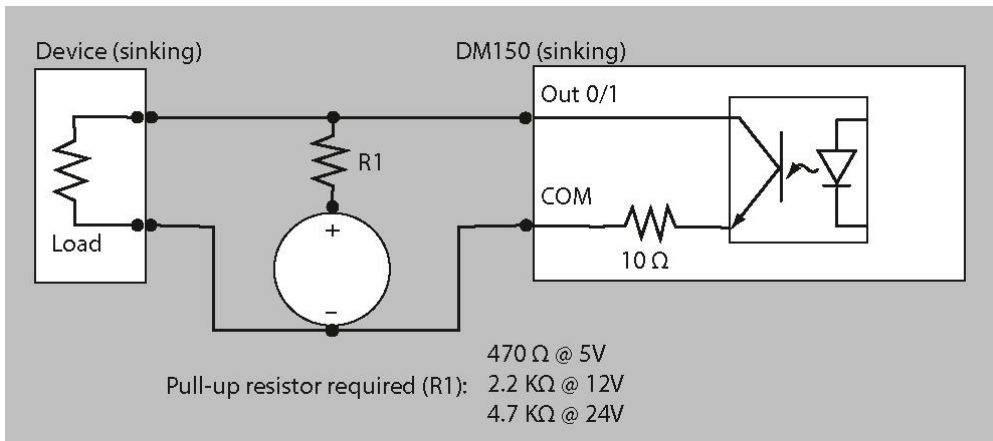
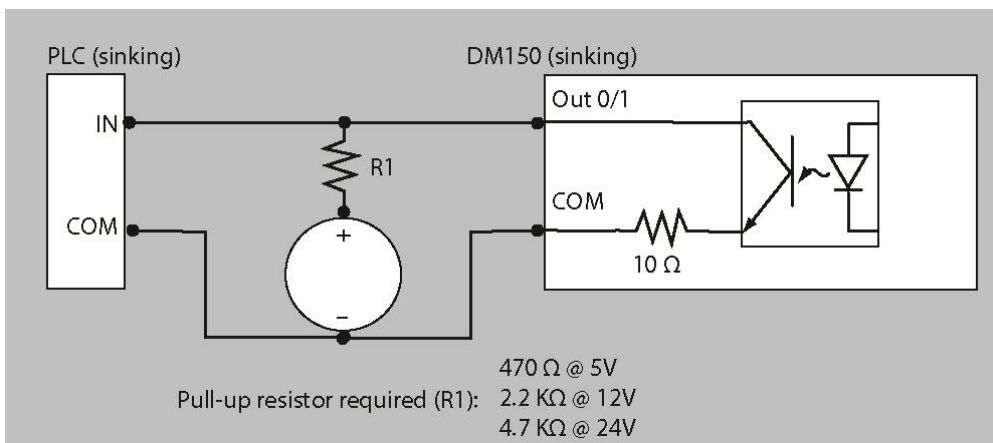

Electrical Information

DataMan 260 Discrete I/O Connector

The I/O breakout cable (CCBL-05-01) provides access to trigger and high-speed outputs. You can clip unused wires short or use a tie made of non-conductive material to tie them back. For RS-232, use the Power Supply return path for ground.

The figure on the left shows the plug on the device.

Signal: 24 VDC Ethernet Model

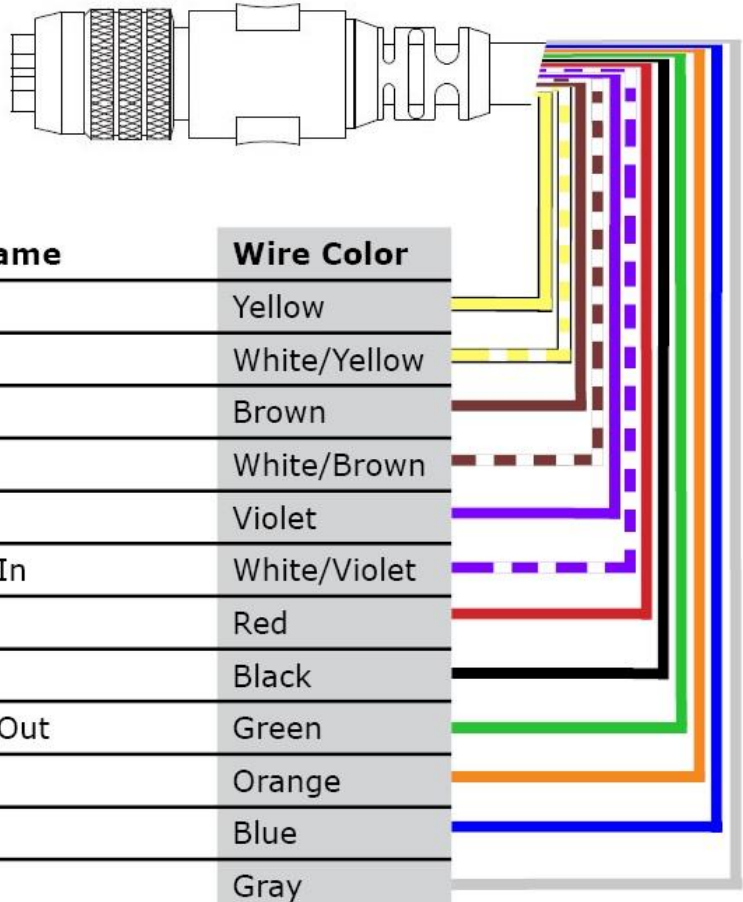

Pin #	Signal Name	Wire Color
1	Out 2	Yellow
2	TxD	White/Yellow
3	RxD	Brown
4	Out 3	White/Brown
5	In 1	Violet
6	Common In	White/Violet
7	+24 VDC	Red
8	GND	Black
9	Common Out	Green
10	In 0	Orange
11	Out 0	Blue
12	Out 1	Gray

Signal: PoE Ethernet Model

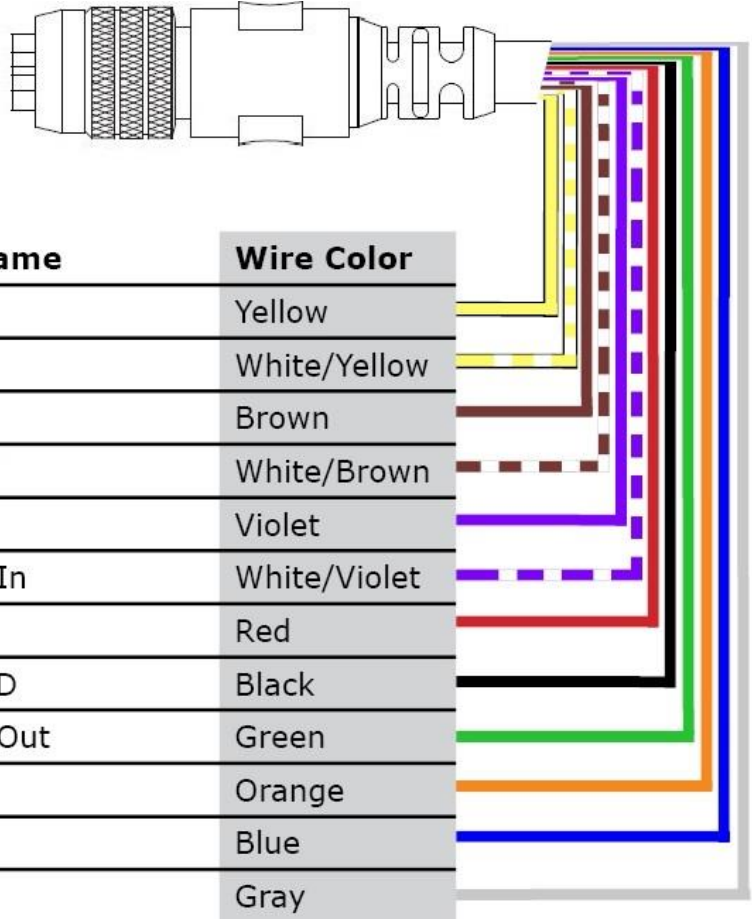

DataMan 260 Ethernet Cable

The Ethernet cable (CCB-84901-2001-05) provides Ethernet connection for network communications. The Ethernet cable can be connected to a single device or provide connections to multiple devices via a network switch or router.

Note: Cables are sold separately. The wiring for this cable follows standard industrial Ethernet M12 specifications. It differs from the 568B standard.

X-coded to RJ45 Cable

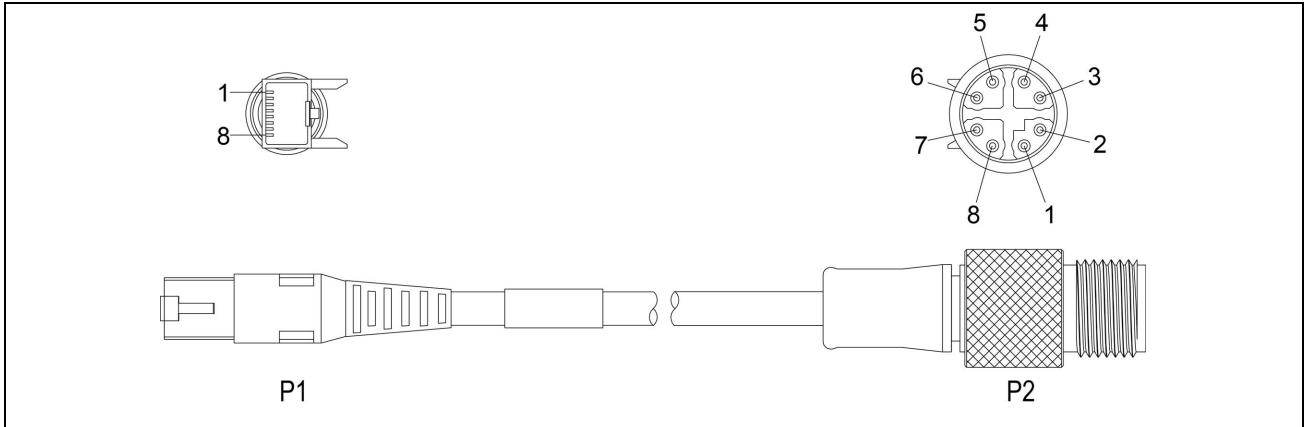

P1 Pin Number	Wire Color	Signal Name	P2 Pin Number
1	White/Orange	TxRx A +	1
2	Orange	TxRx A -	2
3	White/Green	TxRx B +	3
4	Blue	TxRx C +	8
5	White/Blue	TxRx C -	7
6	Green	TxRx B -	4
7	White/Brown	TxRx D +	5
8	Brown	TxRx D -	6

DataMan 280 Ethernet Cable

The Ethernet cable provides Ethernet connectivity to the reader. The Ethernet cable is used to connect the reader to other network devices.

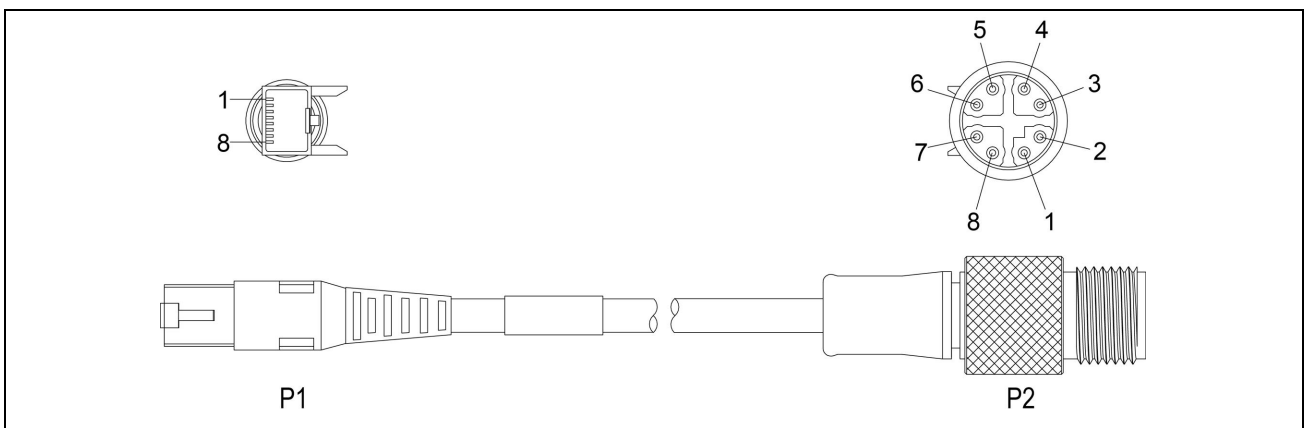

P1 Pin Number	Wire Color	Signal Name	P2 Pin Number
1	White/Orange	TxRx A +	1
2	Orange	TxRx A -	2
3	White/Green	TxRx B +	3
4	Blue	TxRx C +	8

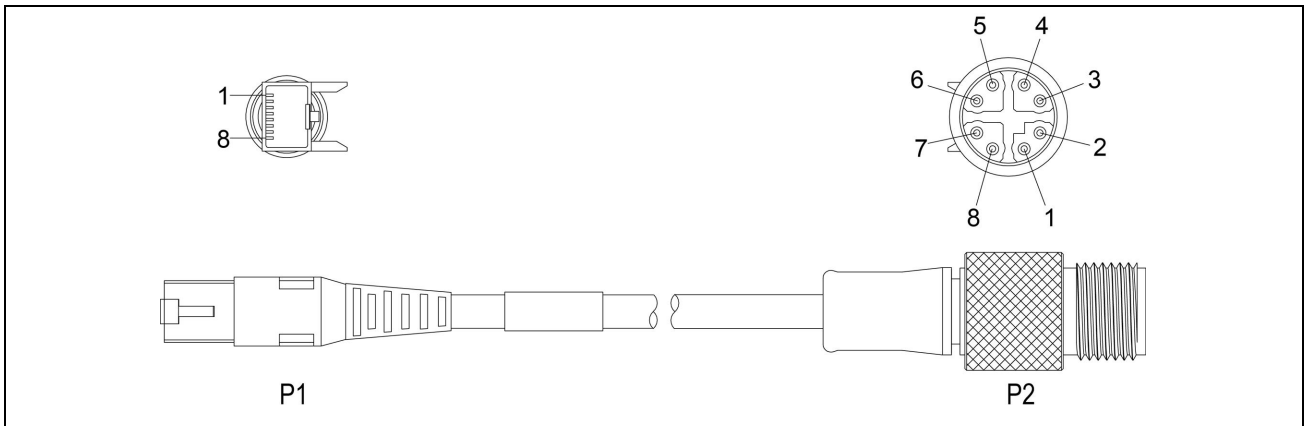

P1 Pin Number	Wire Color	Signal Name	P2 Pin Number
5	White/Blue	TxRx C -	7
6	Green	TxRx B -	4
7	White/Brown	TxRx D +	5
8	Brown	TxRx D -	6

CAUTION: The Ethernet cable shield has to be grounded at the far end. Whatever this cable is plugged into (typically a switch or router) should have a grounded Ethernet connector. A digital voltmeter has to be used to validate the grounding. If the far end device is not grounded, a ground wire should be added in compliance with local electrical codes.

Note:

- Cables are sold separately.
- The wiring for this cable follows standard industrial Ethernet M12 specifications. It differs from the 568B standard.

DataMan 150 and 260 Acquisition Triggering

The acquisition trigger input on the reader is opto-isolated.

To trigger from an NPN (pull-down) type photo-detector or PLC output, connect **In 0** to +24 V and connect **Common In** to the output of the detector. When the output turns on, it pulls **Common In** down to 0 V, turning the opto-coupler on.

To trigger from a PNP (pull-up) photo-detector or PLC output, connect **In 0** to the output of the detector and connect **Common In** to 0 V. When the output turns on, it pulls **In 0** up to 24 V, turning the opto-coupler ON.

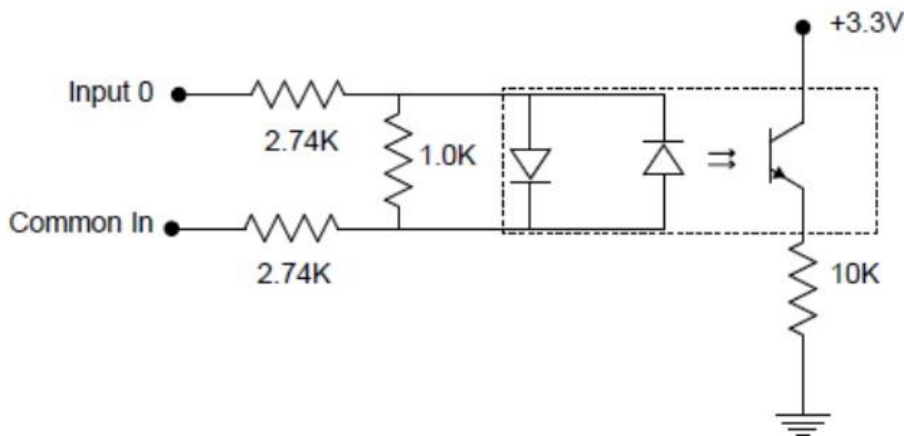

28 V maximum across input pins - Transition approximately 12 V (Min).

DataMan 280 Acquisition Triggering

The reader features one acquisition trigger input, which is optically isolated. You can configure the acquisition trigger input to trigger from an NPN (current sinking) or PNP (current sourcing) device.

- To trigger from an NPN type photoelectric sensor or PLC output, connect **COMMON IN** to +24 VDC and connect **IN 0** to the output of the photoelectric sensor. When the output turns ON, it pulls TRIGGER down to 0 VDC, turning the opto-coupler ON.
- To trigger from a PNP photoelectric sensor or PLC output, connect **IN 0** to the output of the photoelectric sensor and connect **COMMON IN** to 0 VDC. When the output turns ON, it pulls TRIGGER up to +24 VDC, turning the opto-coupler ON.

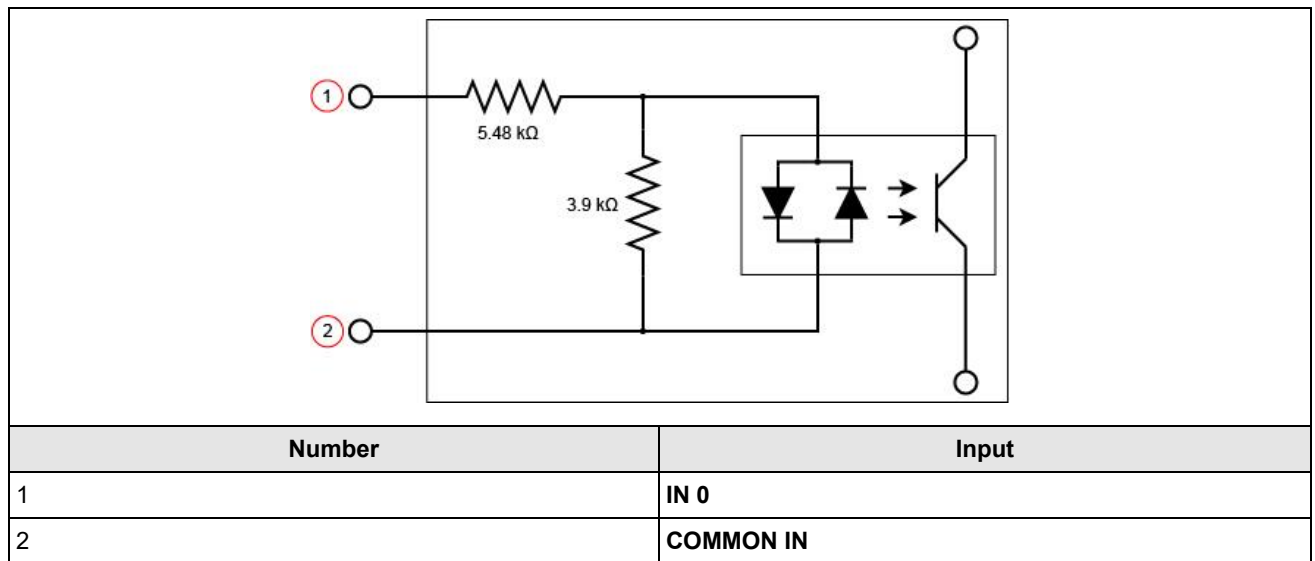

DataMan 260 High-Speed Output Lines

The high-speed outputs can be used as either NPN (pull-down) or PNP (pull-up) lines.

Specification	Description
Voltage	28 V maximum through external load
Current	50 mA maximum sink current OFF state leakage current 100 μ A External load resistance 240 Ohms to 10K Ohms Each line rated at a maximum 50 mA, protected against over-current, short circuits and transients from switching inductive loads. High current inductive loads require external protection diode.

For NPN lines, the external load should be connected between the output and the positive supply voltage (<28 V). The outputs pull down to less than 3 VDC when ON, which causes current to flow through the load. When the outputs are OFF, no current flows through the load.

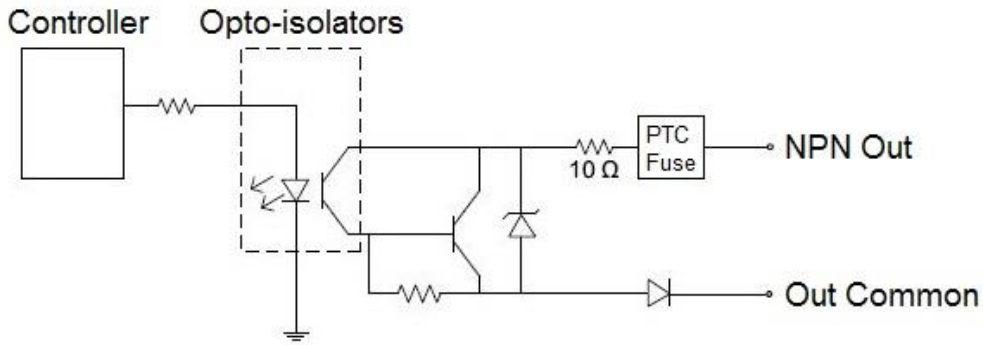

For PNP lines, the external load should be connected between the output and the negative supply voltage (0 VDC). When connected to a 24 VDC power supply, the outputs pull up greater than 21 VDC when ON, and current flows through the load. When the outputs are OFF, no current flows through the load.

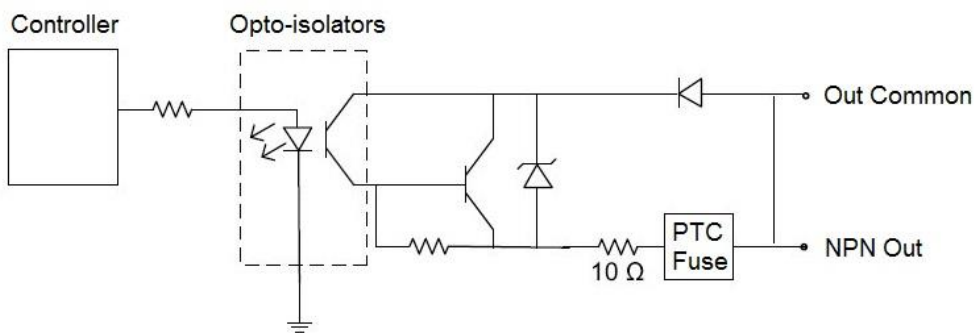

DataMan 260 High-Speed Output Wiring

To connect to an NPN-compatible PLC input, connect Output 0, Output 1, Output 2 or Output 3 directly to the PLC input. When enabled, the output pulls the PLC input down to less than 3 VDC.

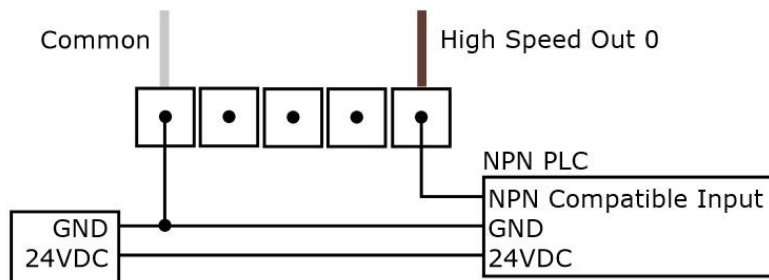

To connect to a PNP-compatible PLC input, connect Output 0, Output 1, Output 2 or Output 3 directly to the PLC input. When enabled, the output pulls the PLC input up to greater than 21 VDC.

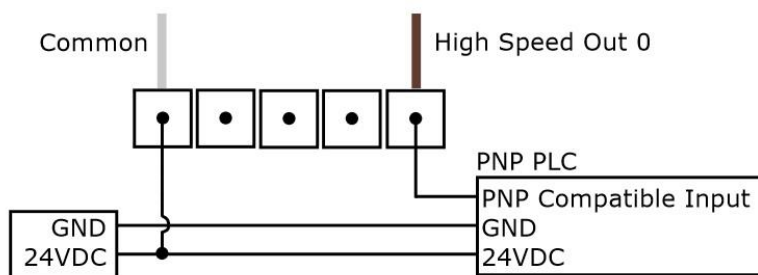

To connect the high-speed outputs to a relay, LED or similar load, connect the negative side of the load to the output and the positive side to +24 VDC. When the output switches on, the negative side of the load is pulled down to less than 3 VDC, and 24 VDC appears across the load. Use a protection diode for a large inductive load, with the anode connected to the output and the cathode connected to +24 VDC.

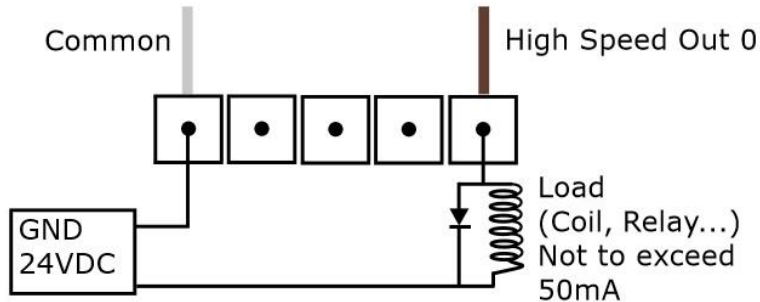

DataMan 280 High-Speed Outputs

Specification	Description
Voltages	V_{MAX} : 26 VDC through external load V_{OL} : $\leq \pm 3$ V @ 50 mA
Current	I_{MAX} : 50 mA maximum sink or source current Each line is protected against over-current, short circuits and transients from switching inductive loads. High current inductive loads require an external protection diode.

For NPN lines, the external load should be connected between the output and the positive supply voltage (< 26 VDC). The output pulls down to less than 3 VDC when ON, which causes current to flow through the load. When the output is OFF, no current flows through the load.

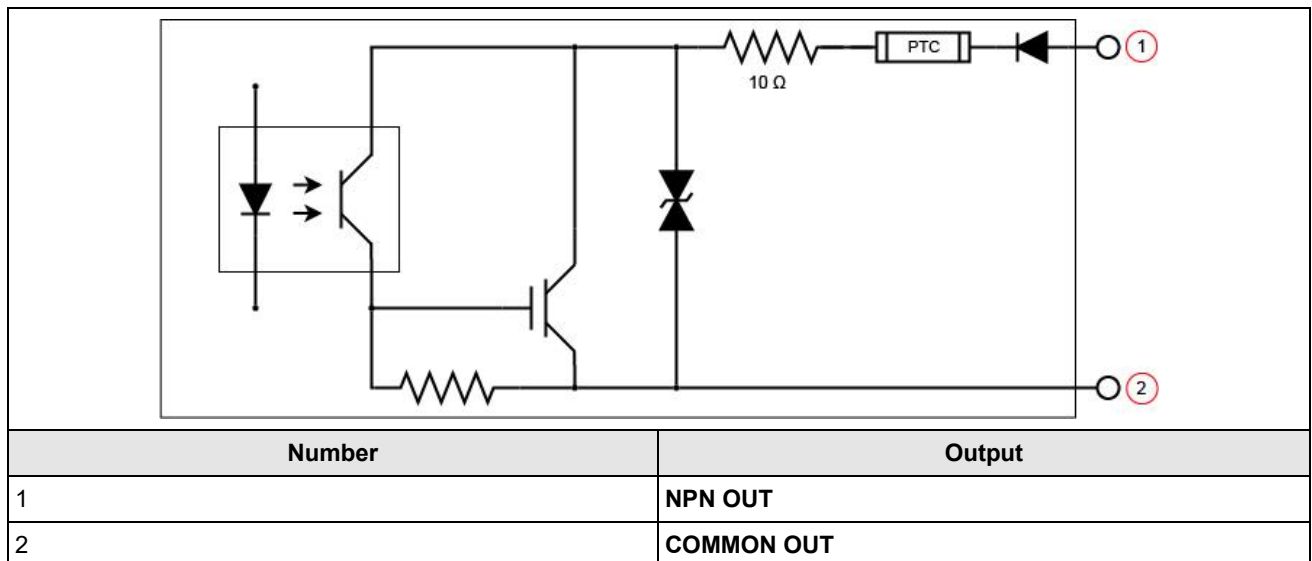

For PNP lines, the external load should be connected between the output and the negative supply voltage (0 VDC). When connected to a 24 VDC power supply, the output pulls up greater than 21 VDC when ON, and current flows through the load. When the output is OFF, no current flows through the load.

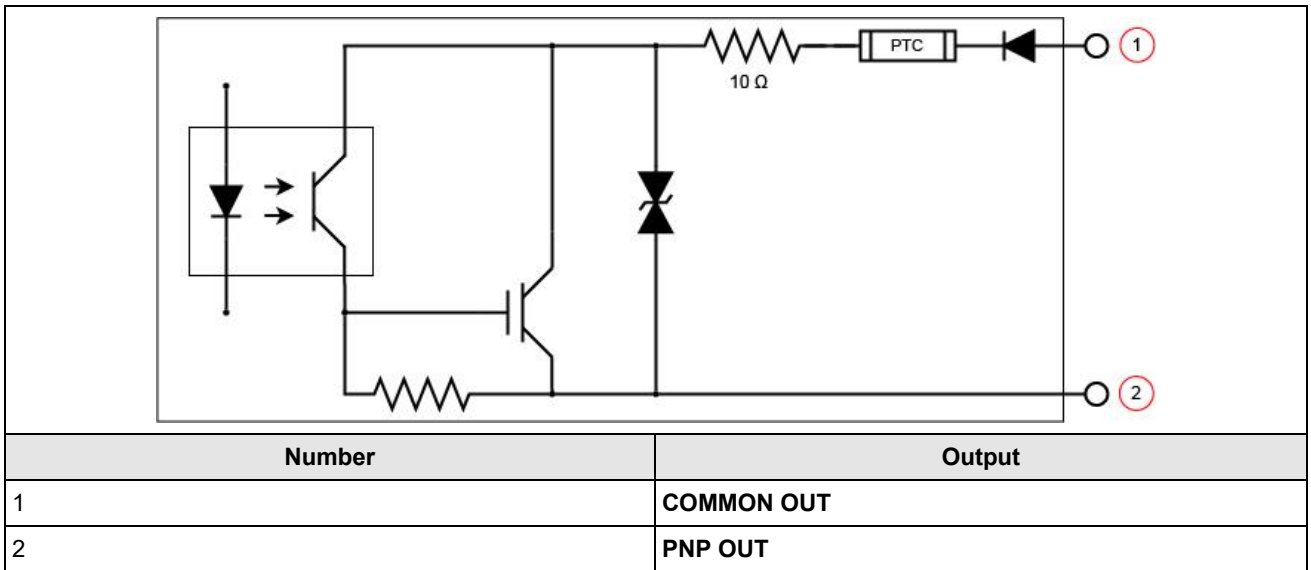

High Speed Output Wiring

To connect to an NPN-compatible PLC input, connect one of the reader's high-speed outputs directly to the PLC input. When enabled, the output pulls the PLC input down to less than 3 VDC.

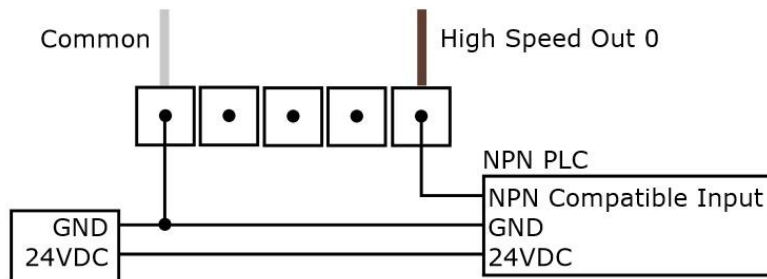

To connect to a PNP-compatible PLC input, connect one of the reader's high-speed outputs directly to the PLC input. When enabled, the output pulls the PLC input up to greater than 21 VDC.

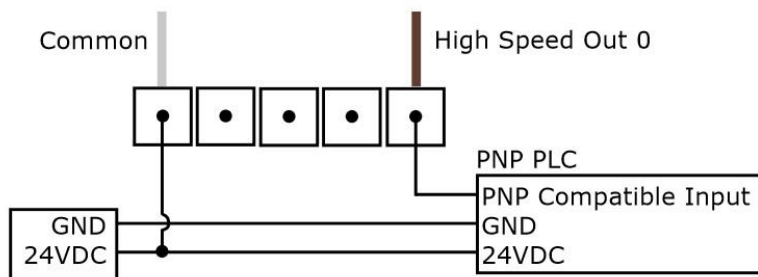

To connect the high-speed outputs to a relay, LED or similar load, connect the negative side of the load to the output and the positive side to +24VDC. When the output switches on, the negative side of the load is pulled down to less than 3 VDC, and 21 VDC appears across the load. Use a protection diode for a large inductive load, with the anode connected to the output and the cathode connected to +24 VDC.

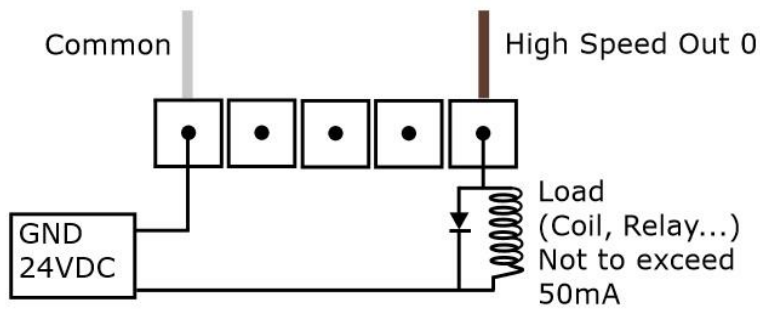

DataMan 280 Discrete I/O Connector

CCBL-05-01 and CCB-PWRIO-05

The Power and I/O Breakout cable provides access to trigger and high-speed outputs. For RS-232, use the Power Supply return path for ground.

The figure on the left shows the plug on the device.

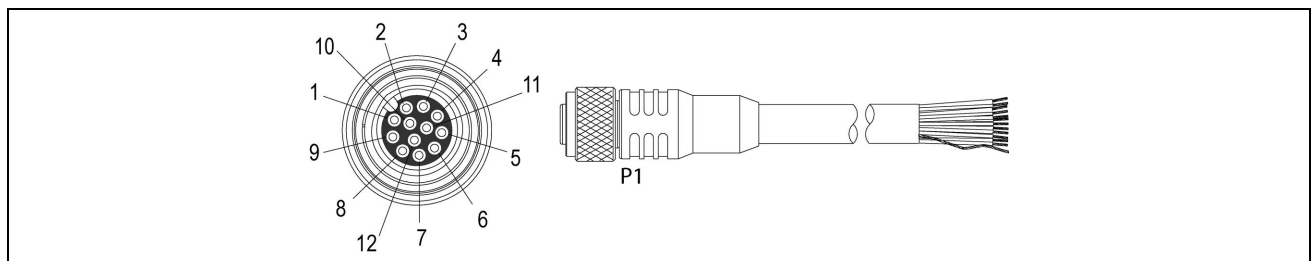

Pin#	Signal Names	Wire Color
1	Out 2/In 2	Yellow
2	TxD	White/Yellow
3	RxD	Brown
4	Out 3/In 3	White/Brown
5	In 1	Violet
6	Common In	White/Violet
7	+24 VDC	Red
8	GND	Black
9	Common Out	Green
10	In 0	Orange
11	Out 0	Blue
12	Out 1	Grey

CCB-M12x12Fy-xx

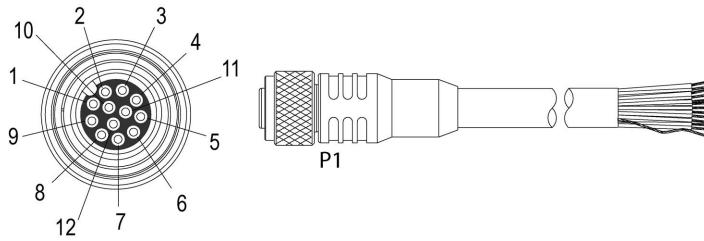

Pin#	Signal Names	Wire Color
1	Out 2/In 2	White
2	TxD	Green
3	RxD	Pink
4	Out 3/In 3	Yellow
5	In 1	Grey
6	Common In	Black
7	+24 VDC	Brown
8	GND	Blue
9	Common Out	Purple
10	In 0	Red
11	Out 0	Grey/Pink
12	Out 1	Red/Blue

Note:

- Cables are sold separately.
- Perform wiring or adjustments to I/O devices when the reader is not receiving power.
- You can cut exposed wires short or trim wire ends. You also can tie the wires back if you use a tie made of non-conductive material. Keep bare wires separated from the +24 V DC wire.

Dataman 300 5m RS-232 Connection Cable (CCB-M12XDB9Y-05)

You can clip unused wires short or use a tie made of non-conductive material to tie them back.

The figure on the left shows the plug on the device.

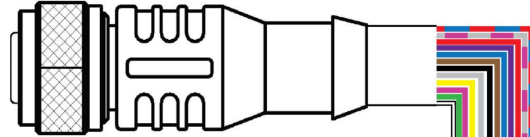

Pin #	Signal Name	Wire Color
1	Out 2	White
2	TxD	Green
3	RxD	Pink
4	Out 3	Yellow
5	In 1	Grey
6	Common In	Black
7	+24 VDC	Brown
8	GND	Blue
9	Common Out	Violet
10	In 0	Red
11	Out 0	Grey/Pink
12	Out 1	Red/Blue

DataMan 300, 360, 370, and 470 Series Readers Discrete I/O Connector

The Breakout cable provides access to trigger and high-speed outputs. You can clip unused wires short or use a tie made of non-conductive material to tie them back. For RS-232, use the Power Supply return path for ground.

5m Breakout Cable (CCBL-05-01)

The figure on the left shows the plug on the device.

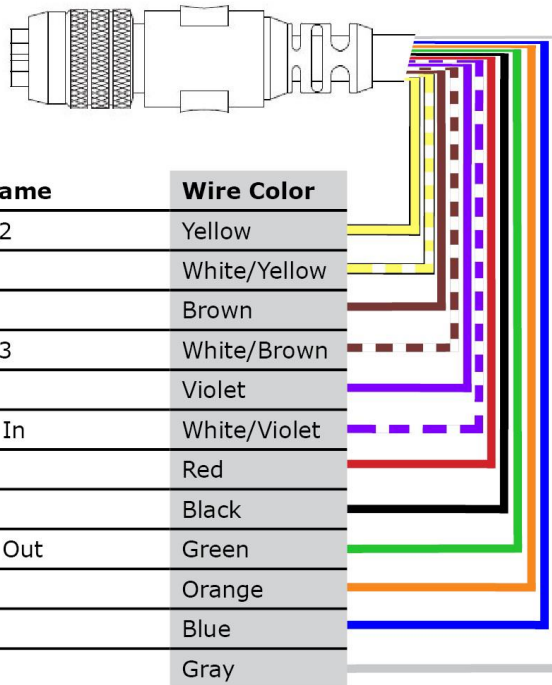

Pin #	Signal Name	Wire Color
1	Out 2/In 2	Yellow
2	TxD	White/Yellow
3	RxD	Brown
4	Out 3/In 3	White/Brown
5	In 1	Violet
6	Common In	White/Violet
7	+24 VDC	Red
8	GND	Black
9	Common Out	Green
10	In 0	Orange
11	Out 0	Blue
12	Out 1	Gray

5m Breakout Cable (CCB-M12x12Fy-xx)

The figure on the left shows the plug on the device.

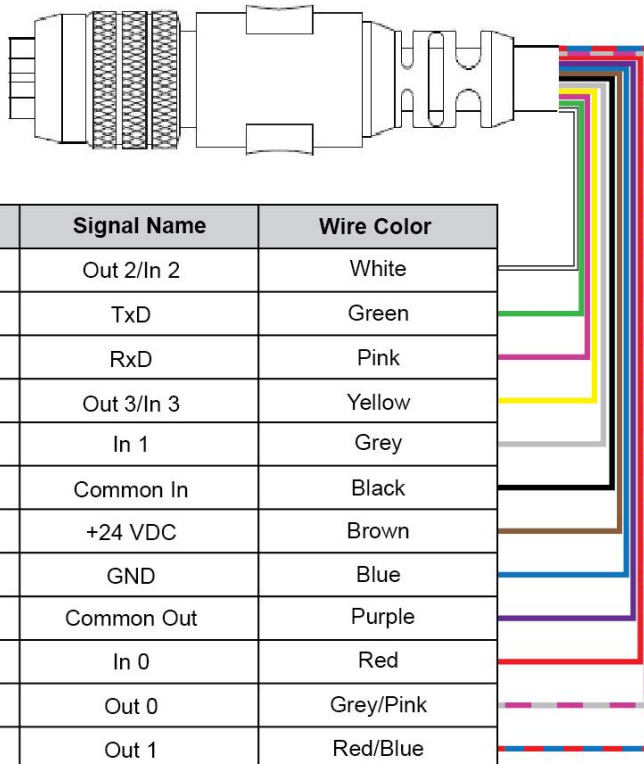

Pin #	Signal Name	Wire Color
1	Out 2/In 2	White
2	TxD	Green
3	RxD	Pink
4	Out 3/In 3	Yellow
5	In 1	Grey
6	Common In	Black
7	+24 VDC	Brown
8	GND	Blue
9	Common Out	Purple
10	In 0	Red
11	Out 0	Grey/Pink
12	Out 1	Red/Blue

15m Breakout Cable (CCB-PWRIO-XX)

The figure on the left shows the plug on the device.

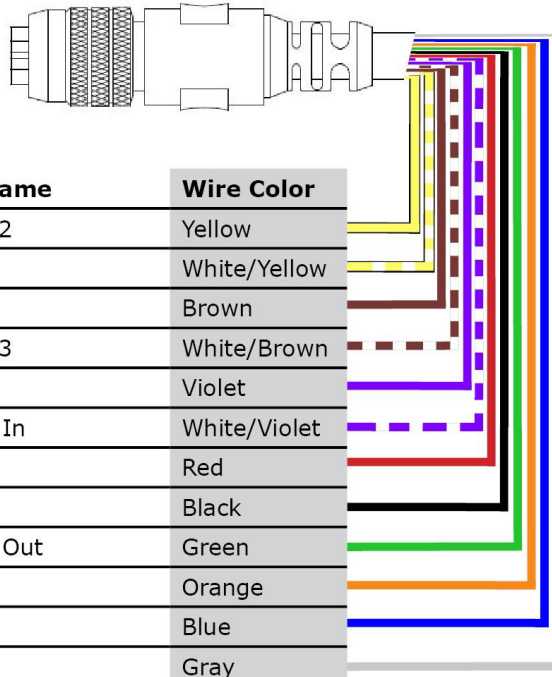

DataMan 300, 360, 370, and 470 Series Readers External Light Control

The External Light cable is used to connect to an external lighting device, providing power and strobe control.

A 4-pin cable is provided for the external light control. The drawing on the left shows the socket on the device. This socket does not work if the external light is connected to one of the outputs on the breakout cable.

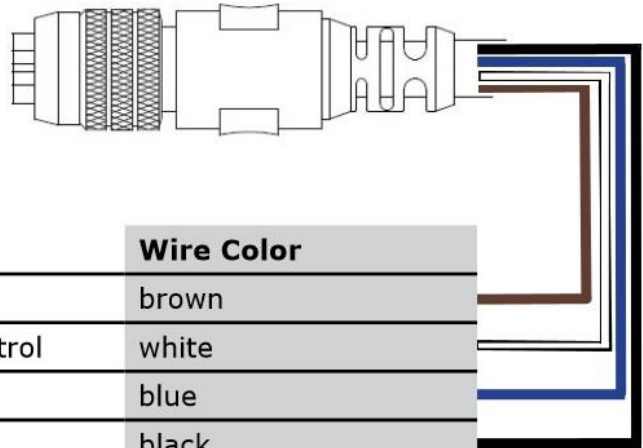
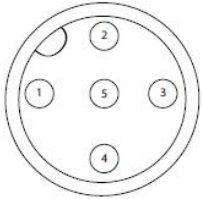

Pin #	Signal Name	Wire Color
1	+24 VDC	brown
2	Brightness Control	white
3	GND	blue
4	Strobe	black
5	Chassis	not connected

Output Voltage	24 V +/-5% (20 V – 27 V) Voltage may drop depending on the length of the cable.	
	Max avg Current	1 A
	Peak Operating Current	1.5 A up to 100 μ s, avg to not exceed 1 A
	Max Inrush Current	5 A not exceeding 0.4 As

DataMan 300, 360, 370, and 470 Series Readers Power Requirements

For the DataMan 300, 360, 370, and 470 series readers, 24 VDC power is provided through the I/O+RS232+24 V cable. Maximum power consumption is 5 W (internal illumination) or 18 W (internal and external lights).

DataMan 300, 360, 370, and 470 Series and DataMan 503 Readers Acquisition Triggering

The acquisition trigger input on the reader is opto-isolated.

To trigger from an NPN (pull-down) type photo-detector or PLC output, connect **Common In** to +24 VDC and connect **In** to the output of the detector. When the output turns on, it pulls **In** down to 0 VDC, turning the opto-coupler on.

To trigger from an PNP (pull-up) photo-detector or PLC output, connect **In 0** to the output of the detector and connect **Common In** to 0 VDC. When the output turns on, it pulls **In 0** up to 24 VDC, turning the opto-coupler ON.

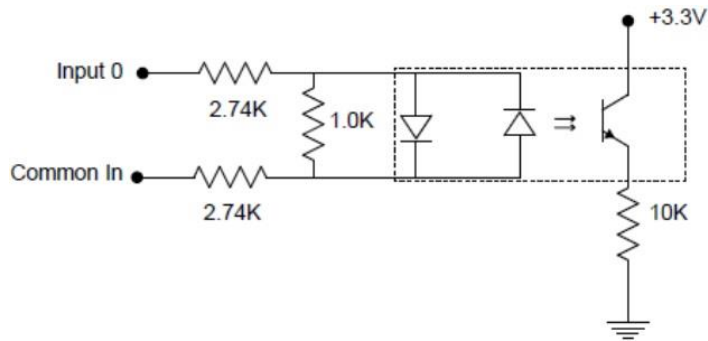

The DataMan 300, 360, 370, and 470 series readers support 26.4 V maximum across input pins – Transition approximately 12 V (Min.). The DataMan 503 reader supports 28 V maximum across input pins - Transition approximately 12 V (Min.).

DataMan 300, 360, 370, and 470 Series, and DataMan 503 Readers High-Speed Output Lines

The high-speed outputs can be used as either NPN (pull-down) or PNP (pull-up) lines.

Specification	DataMan 300, 360, 370, and 470 Series Readers, and DataMan 503 Reader Description
Voltage	26.4 V maximum through external load
Current	50 mA maximum sink current OFF state leakage current 100 μ A External load resistance 240 Ohms to 10K Ohms Each line rated at a maximum 50 mA, protected against over-current, short circuits and transients from switching inductive loads. High current inductive loads require external protection diode.

For NPN lines, the external load should be connected between the output and the positive supply voltage (<26.4 VDC). The outputs pull down to less than 3 VDC when ON, which causes current to flow through the load. When the outputs are OFF, no current flows through the load.

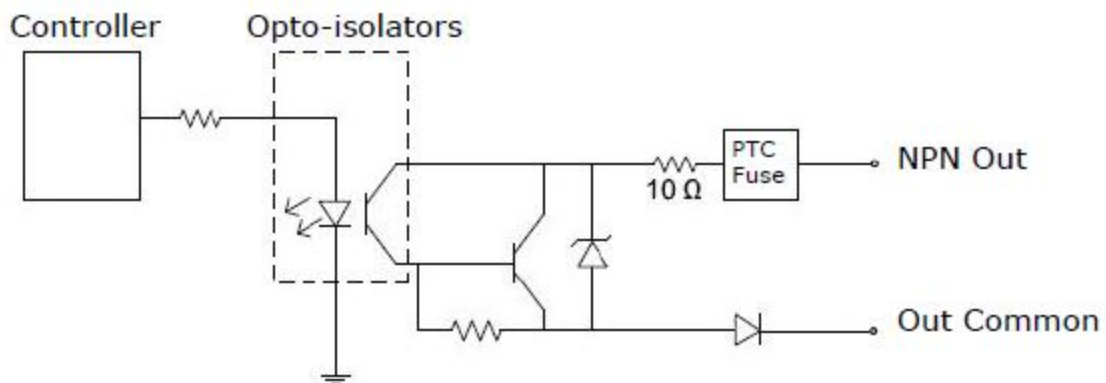

For PNP lines, the external load should be connected between the output and the negative supply voltage (0 VDC). When connected to a 24 VDC power supply, the outputs pull up greater than 21 VDC when ON, and current flows through the load. When the outputs are OFF, no current flows through the load.

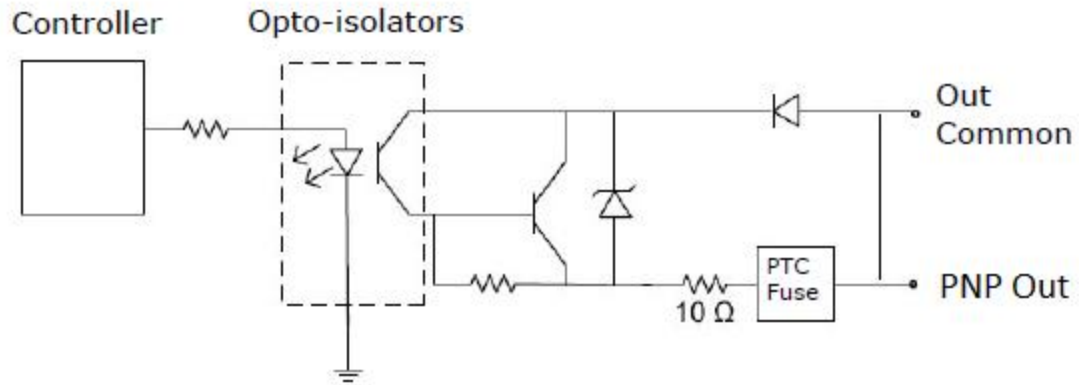

DataMan 300, 360, 370, and 470 Series Readers High-Speed Output Wiring

To connect to an NPN-compatible PLC input, connect Output 0, Output 1, Output 2, or Output 3 directly to the PLC input. When enabled, the output pulls the PLC input down to less than 3 VDC.

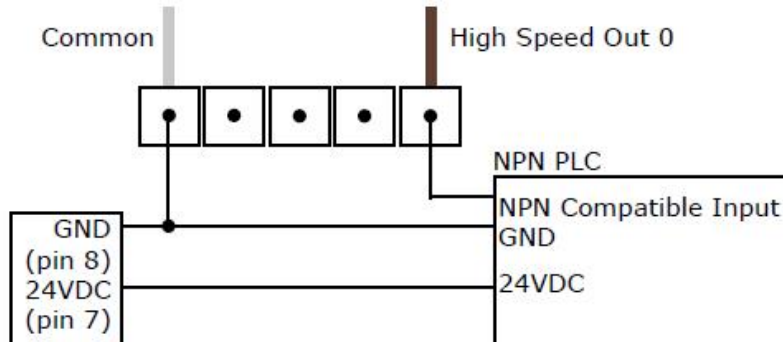

To connect to a PNP-compatible PLC input, connect Output 0, Output 1, Output 2 or Output 3 directly to the PLC input. When enabled, the output pulls the PLC input up to greater than 21 VDC.

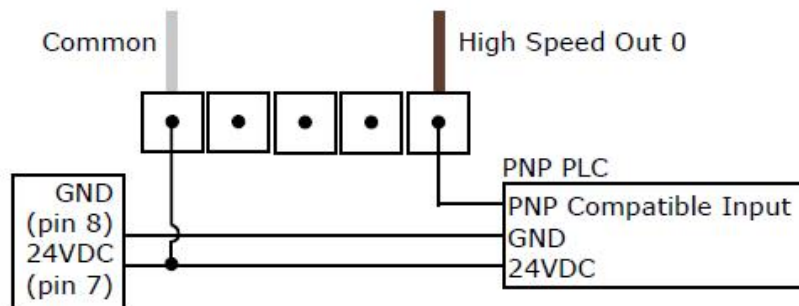

To connect the high-speed outputs to a relay, LED or similar load, connect the negative side of the load to the output and the positive side to +24 VDC. When the output switches on, the negative side of the load is pulled down to less than 3 VDC, and 24 appears across the load. Use a protection diode for a large inductive load, with the anode connected to the output and the cathode connected to +24 VDC.

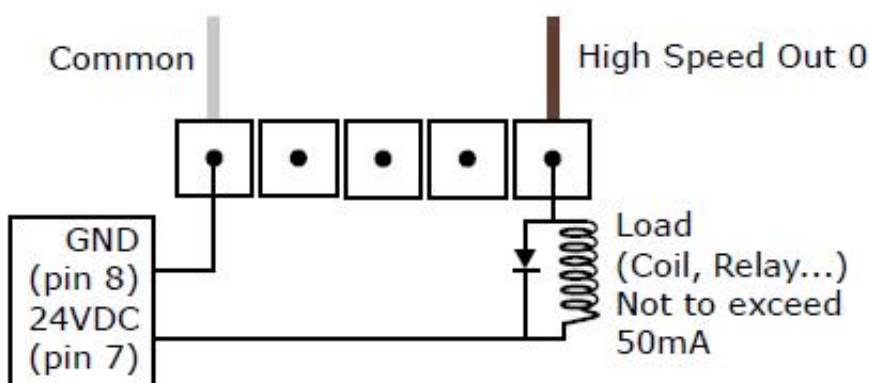

DataMan 300 and 503 Ethernet M12 to RJ45 Cable (CCB-84901-y00x-xx)

The Ethernet cable provides Ethernet connection for network communications. The Ethernet cable can be connected to a single device or provide connections to multiple devices via a network switch or router.

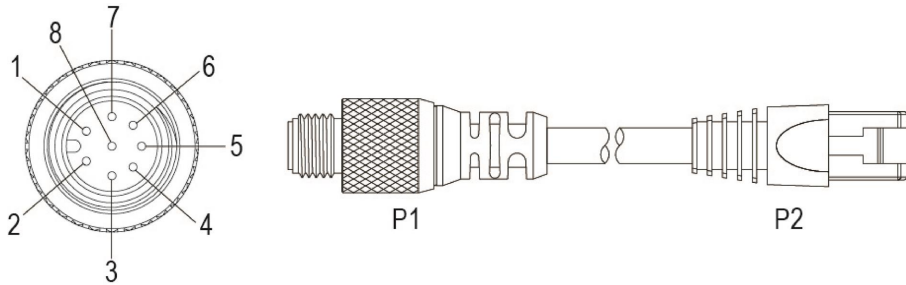

P1 Pin#	Signal Name	Wire Color	P2 Pin#
6	TPO+	White/Orange	1
4	TPO-	Orange	2
5	TPI+	White/Green	3
7	TRMA	Blue	4
1	TRMB	White/Blue	5
8	TPI-	Green	6
2	TRMC	White/Brown	7
3	TRMD	Brown	8

DataMan 503 Discrete I/O Connector

5 m Breakout Cable (CCBL-05-01)

The Breakout cable provides access to trigger and high-speed outputs. You can clip unused wires short or use a tie made of non-conductive material to tie them back.

The figure on the left shows the plug on the device.

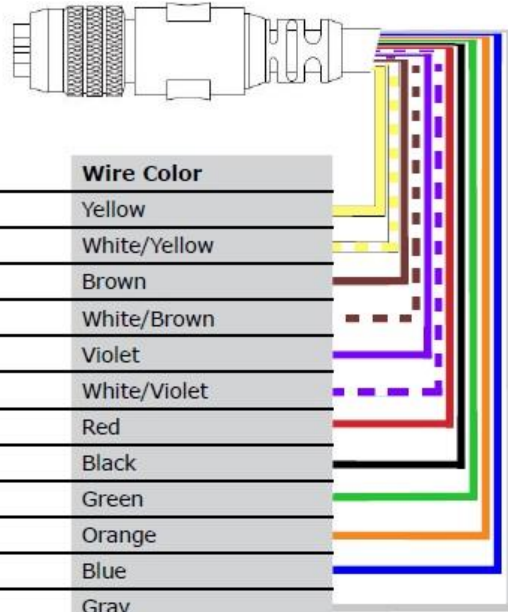

Pin #	Signal Name	Wire Color
1	Out 2	Yellow
2	In 3	White/Yellow
3	In 2	Brown
4	Out 3	White/Brown
5	In 1	Violet
6	Common In	White/Violet
7	+24 VDC	Red
8	GND	Black
9	Common Out	Green
10	In 0	Orange
11	Out 0	Blue
12	Out 1	Gray

DataMan 503 RS-232 Serial Connector

The RS-232 cable (CCB-M8X4.xx) provides an optional connection between the reader and your PC.

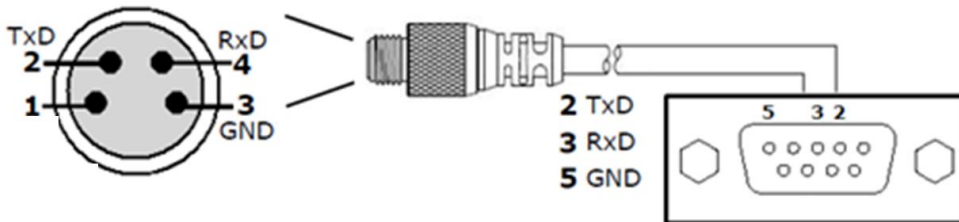

DataMan 503 External Light Control

A 4-pin cable (CCB-M12x4MS) is provided for the external light control.

The drawing on the left shows the socket on the device. This socket does not work if the external light is connected to one of the outputs on the I/O cable.

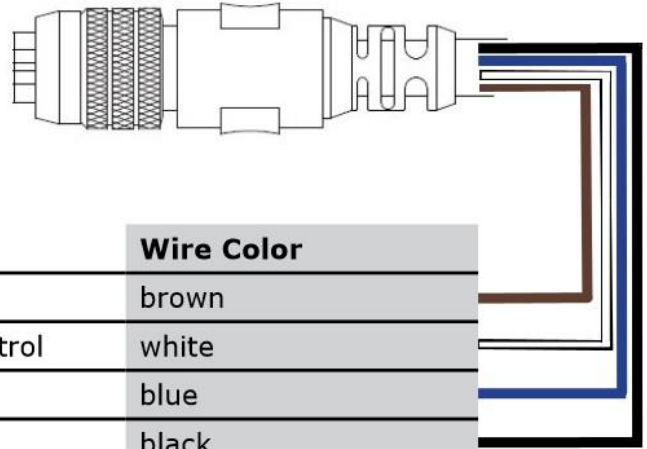
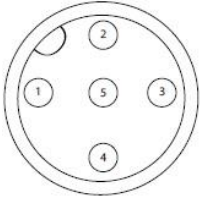

Pin #	Signal Name	Wire Color
1	+24 VDC	brown
2	Brightness Control	white
3	GND	blue
4	Strobe	black
5	Chassis	not connected

Current load: average: 500 mA, peak: 1 A (max. 100 μ s).

Note: This socket does not work if the external light is connected to one of the outputs on the I/O cable.

DataMan 503 High-Speed Output Wiring

To connect to an NPN-compatible PLC input, connect Output 0, Output 1, Output 2, or Output 3 directly to the PLC input. When enabled, the output pulls the PLC input down to less than 3 VDC.

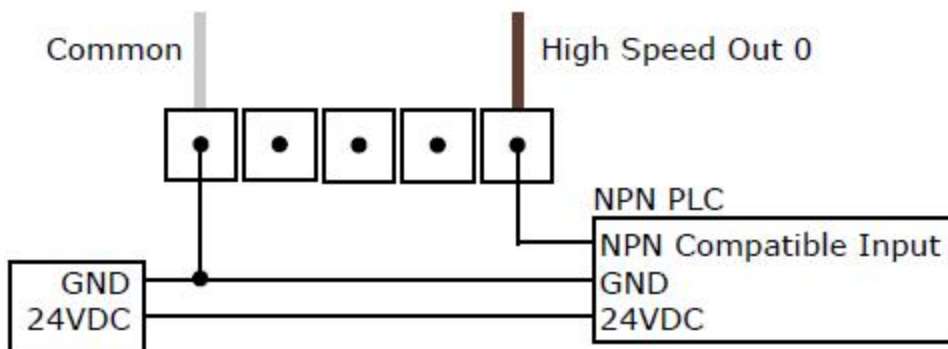

To connect to a PNP-compatible PLC input, connect Output 0 or Output 1 directly to the PLC input. When enabled, the output pulls the PLC input up to greater than 21 VDC.

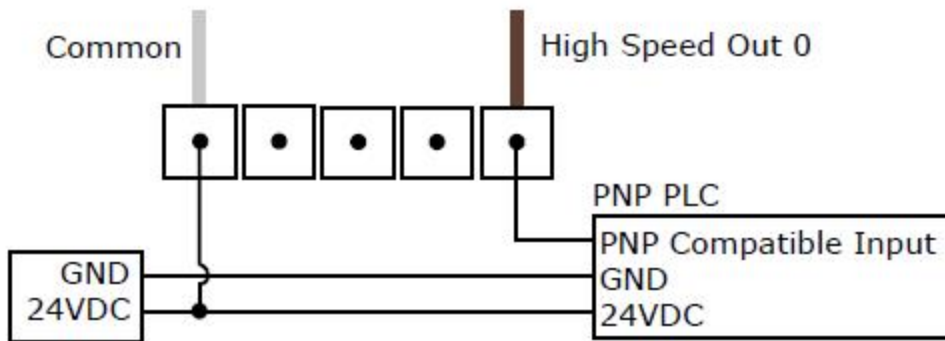

To connect the high-speed outputs to a relay, LED or similar load, connect the negative side of the load to the output and the positive side to +24 VDC. When the output switches on, the negative side of the load is pulled down to less than 3 VDC, and 24 appears across the load. Use a protection diode for a large inductive load, with the anode connected to the output and the cathode connected to +24 VDC.

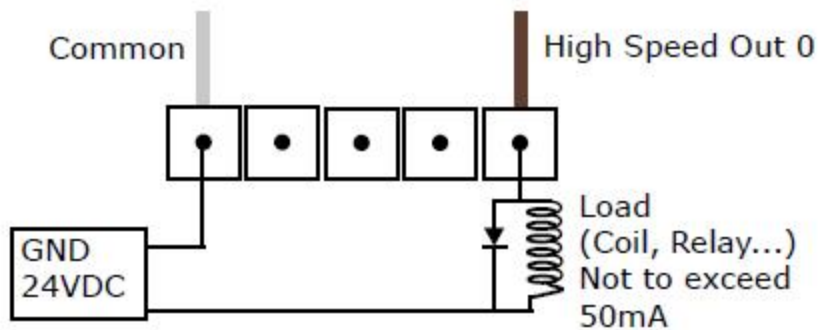

DataMan 503 Power Requirements

For the DataMan 503 readers, 24 VDC power is provided through the I/O+RS232+24 V cable. Maximum power consumption is 13 W (High Power Lighting Module).

Connecting the Encoder to a DataMan

Encoder is supported on the following DataMan devices and with the following conditions:

DM50, DM60, DM70, DM150	unidirectional	One input counts encoder ticks
DM260, DM300, DM503	bidirectional	<ul style="list-style-type: none"> • One input counts encoder ticks • Second input for direction information
DM360	bidirectional	2 inputs for quadrature modulated signals

The DataMan 370 and DataMan 470 series readers are configurable to support all encoder modes listed above.

The encoder has four wires. The color coding of the wires is the following:

Wire Color	Signal Name
Red	+24 VDC
Black	common- can be connected to either +24 VDC (NPN) or ground (PNP)
White	the output connected to the input line of the DataMan reader
Bare	ground

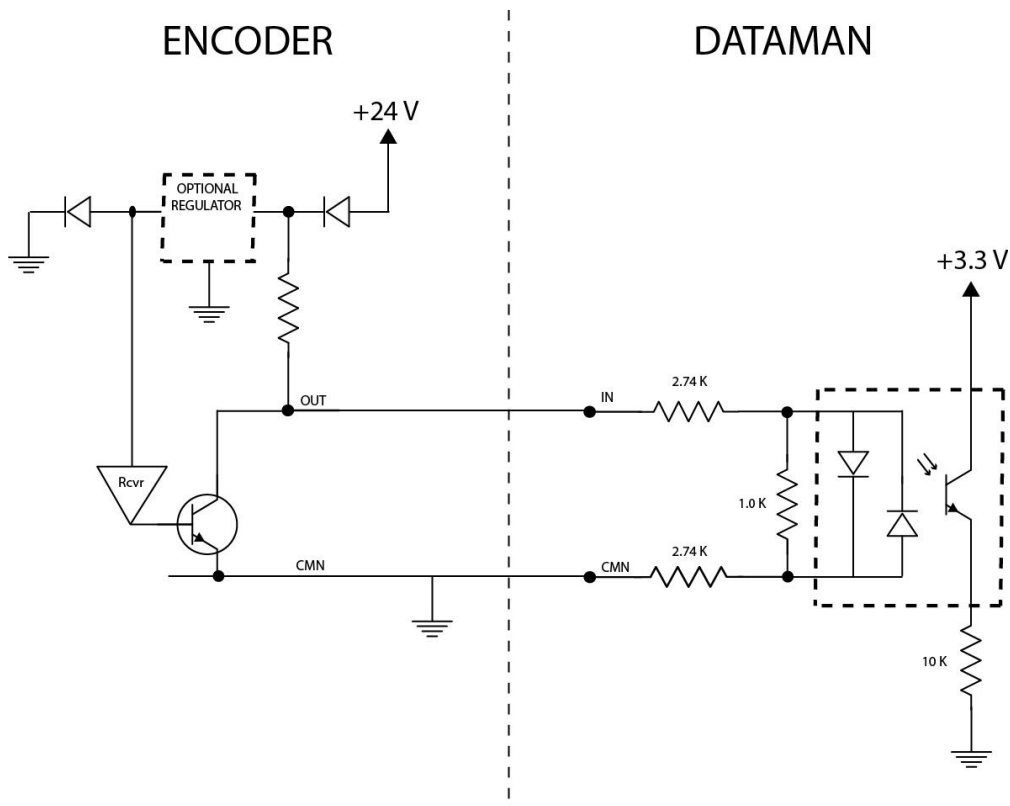

According to the speed of the line, set the number of pulses per revolution on the wheel by using the switches on the encoder (for more information, see the encoder documentation). The number of pulses, however, must not exceed 150 Hz, except for the DataMan 370 and DataMan 470 series readers, which support pulse frequency up to 50 kHz.

In the DataMan Setup Tool, configure the use of your DataMan reader with the encoder in the Pulse Encoder tab of the **Inputs/Outputs** pane.

Optics and Lighting

This section contains information about the image formation components of the DataMan 50, 60, 70, 150, 260, 503 and DataMan 300, 360, 370, and 470 series readers.

DataMan 50 and 60 Reading Distances and Field of View

The following chart shows the horizontal field of view for the DataMan 50 and 60 at a range of working distances, together with the supported range of reading distances at 45 mm focus position.

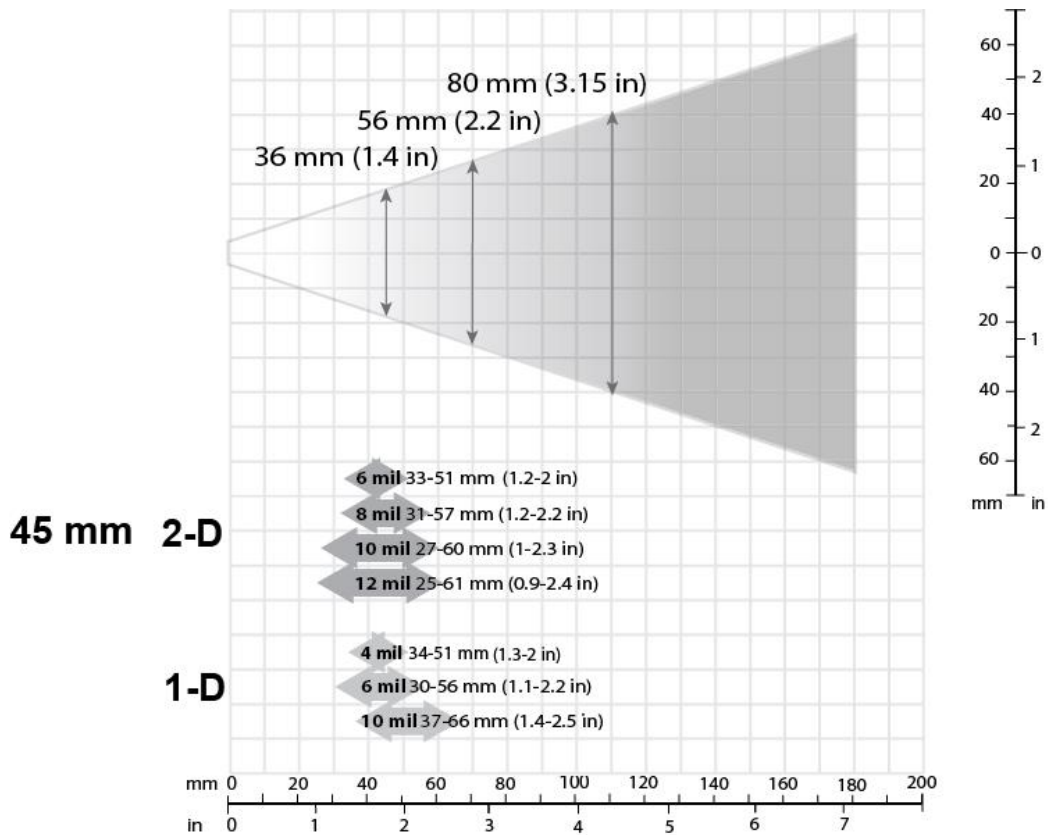

This chart shows the supported range of reading distances at 70 mm focus position.

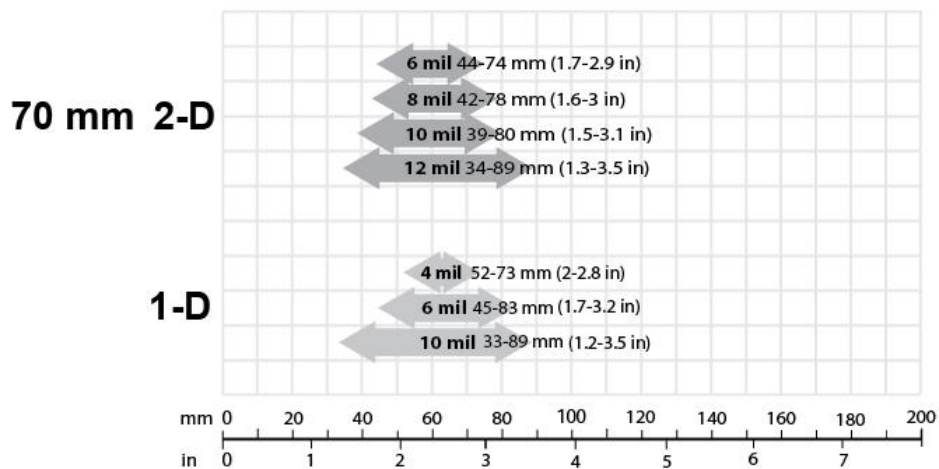

This chart shows the supported range of reading distances at 110 mm focus position.

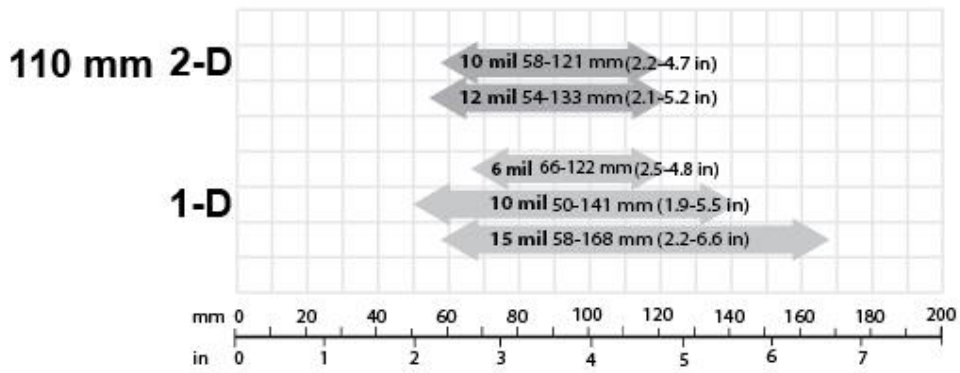

The following table shows the Field of View widths at various distances.

Distances in mm	DM50/DM60
45	36
70	56
110	80

DataMan 70, 150 and 260 Reading Distances and Field of View

DataMan 70, 150 and 260 Readers with a 6.2 mm Lens

Short Range (Focused to 105 mm)

The following tables show the field of view (FoV) widths of the 6.2 mm lens focused to 105 mm at various distances.

DM70, DM150 or DM260

Distances in mm	2D min. code	1D min. code
40	4 MIL	4 MIL
65	5 MIL	4 MIL
105	10 MIL	6 MIL

DM72, DM152 or DM262

Distances in mm	2D min. code	1D min. code
40	3 MIL	2 MIL
65	4 MIL	2 MIL
105	7 MIL	5 MIL

The following maps show the field of view (FoV) of the DataMan 70, DataMan 150 or DataMan 260 readers with a 6.2 mm lens. The horizontal and vertical field of view is shown for working distances of 40 mm, 65 mm and 105 mm.

DM70, DM150 or DM260 + 6.2 mm Lens

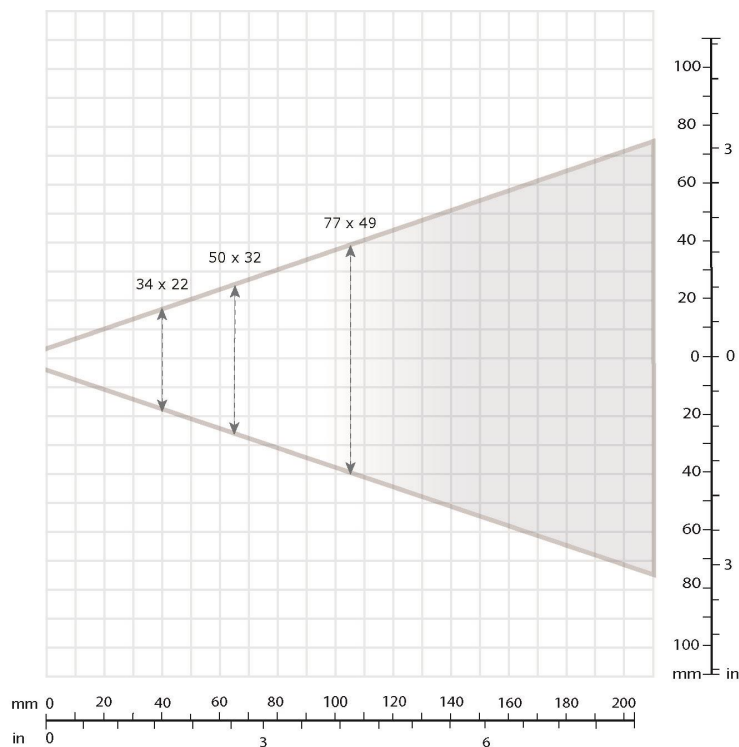

DM72, DM152 or DM262 + 6.2 mm Lens

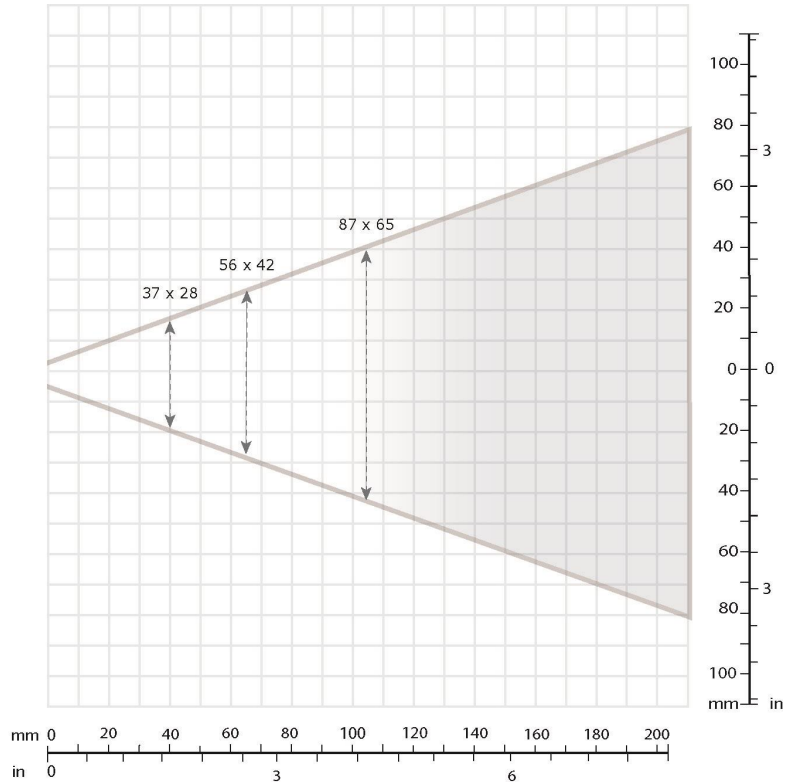

Long Range (Focused to 190 mm)

The following tables show the FoV widths of the 6.2 mm lens focused to 190 mm at various distances.

DM150 or DM260

Distances in mm	2D min. code	1D min. code
150	12 MIL	6 MIL
190	15 MIL	10 MIL
225	18 MIL	10 MIL
375	30 MIL	15 MIL
500	35 MIL	20 MIL
1 m	-	35 MIL

DM152 or DM262

Distances in mm	2D min. code	1D min. code
150	10 MIL	5 MIL
190	12 MIL	6 MIL
225	15 MIL	6 MIL
375	20 MIL	10 MIL
500	25 MIL	15 MIL
1 m	-	30 MIL

The following maps show the field of view (FoV) of the DataMan 150 or DataMan 260 readers with a 6.2 mm lens.

The horizontal and vertical field of view is shown for working distances of 150 mm, 190 mm, 225 mm, 375 mm and 500 mm.

DM150 or DM260 + 6.2 mm Lens

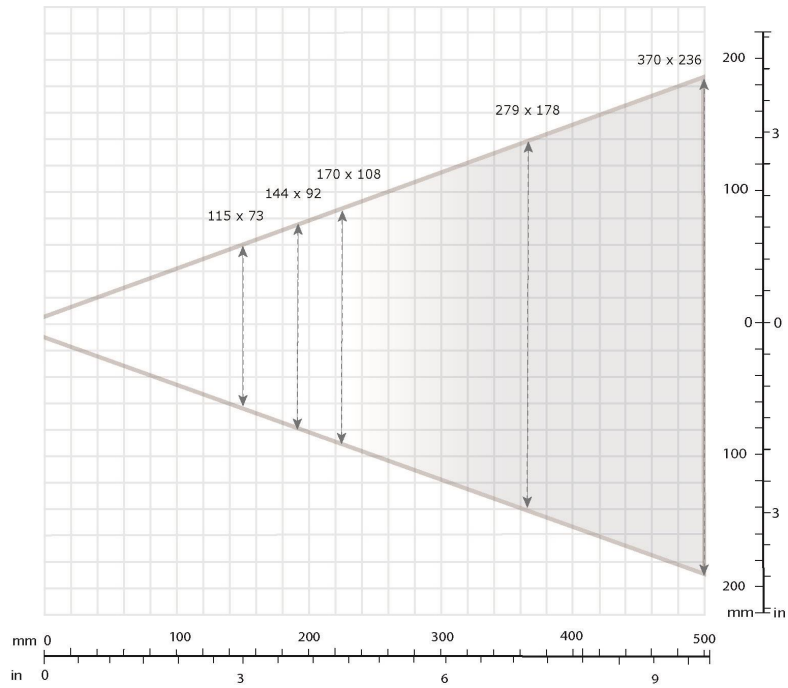

DM152 or DM262 + 6.2 mm Lens

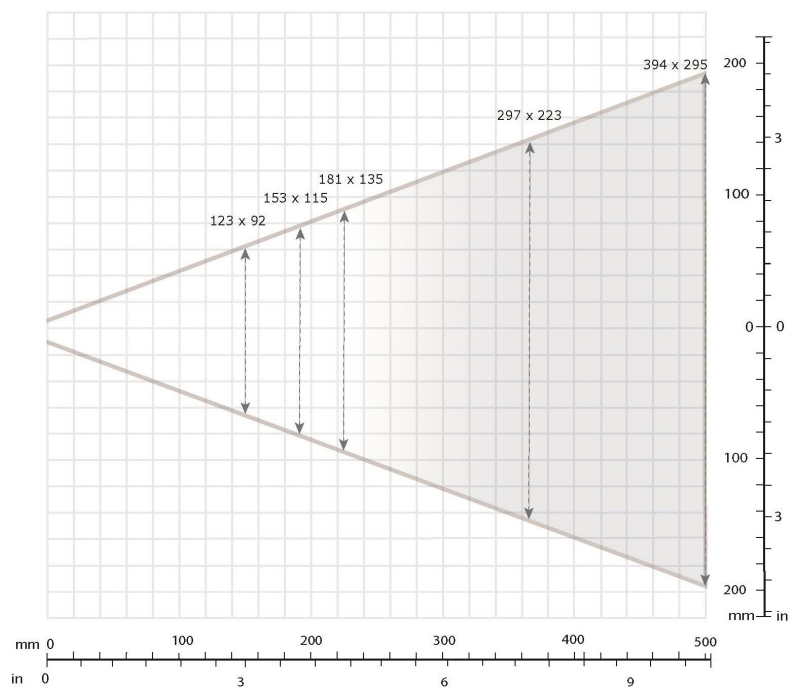

DataMan 150 or DataMan 260 Readers with a 16 mm Lens

The following tables show the field of view (FoV) widths of the 16 mm lens at various distances.

DM150 or DM260

Distances in mm	2D min. code	1D min. code
80	3 MIL	2 MIL
150	5 MIL	3 MIL
190	6 MIL	4 MIL
225	7 MIL	4 MIL
375	12 MIL	5 MIL
500	15 MIL	10 MIL
1 m	25 MIL	15 MIL

DM152 or DM262

Distances in mm	2D min. code	1D min. code
80	2 MIL	2 MIL
150	3 MIL	2 MIL
190	4 MIL	2 MIL
225	4 MIL	3 MIL
375	7 MIL	4 MIL
500	10 MIL	6 MIL
1 m	20 MIL	15 MIL

The following maps show the FoV of the DataMan 150/260 and DataMan 152/262 readers with a 16 mm lens. The horizontal and vertical field of view is shown for working distances of 80 mm, 150 mm, 225 mm, 375 mm, 500 mm and 1000 mm.

DM150 or DM260 + 16 mm Lens

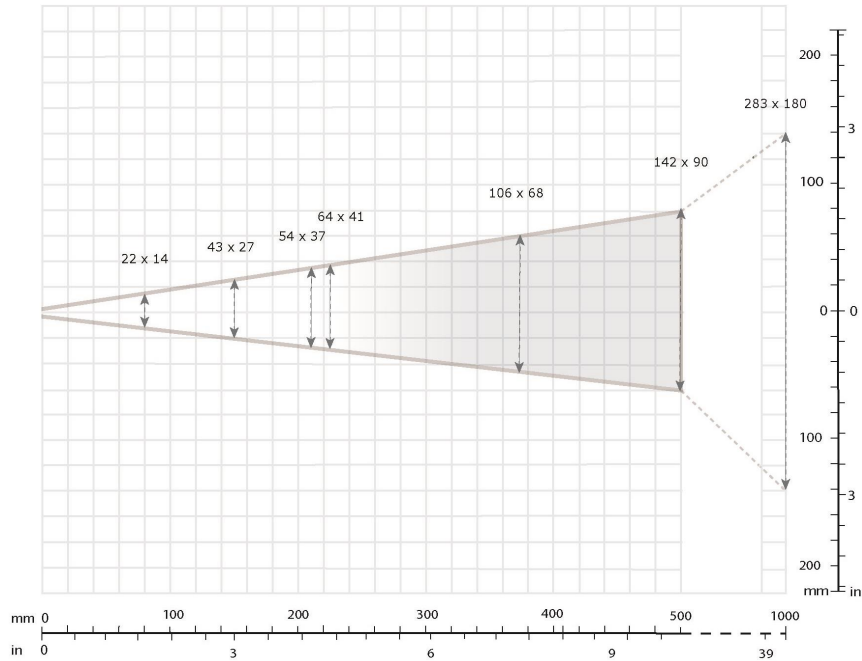

DM152 or DM262 + 16 mm Lens

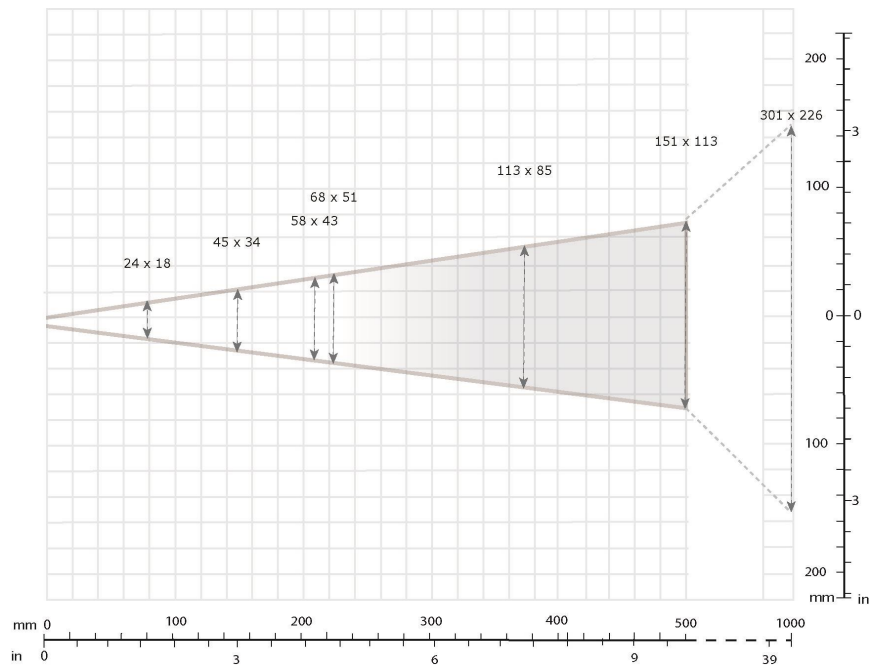

DataMan 280 Reading Distances and Field of View

This section discusses the Field of View values for 6.2 mm and 16 mm lenses.

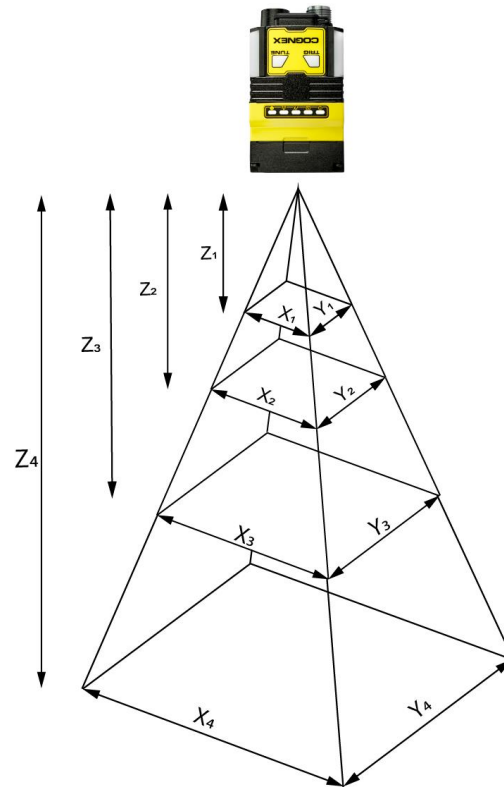

6.2 mm lenses can be focused to 105 mm (short range) and to 190 mm (long range).

The following tables show the Field of View (FoV) widths of the 6.2 mm lens focused to 190 mm at various distances:

Working distance in mm	Horizontal values in mm	Vertical values in mm
$Z_1 = 190$	$X_1 = 159$	$Y_1 = 119$
$Z_2 = 225$	$X_2 = 187$	$Y_2 = 140$
$Z_3 = 375$	$X_3 = 307$	$Y_3 = 230$
$Z_4 = 1000$	$X_4 = 808$	$Y_4 = 606$

Distances in mm	2D min. code in mil	1D min. code in mil
150	10	6
190	12	8
225	15	8
375	20	15
500	30	20
1000	60	35

The following tables show the Field of View (FoV) widths of the 6.2 mm lens focused to 105 mm at various distances:

Working distance in mm	Horizontal values in mm	Vertical values in mm
$Z_1 = 40$	$X_1 = 38$	$Y_1 = 29$
$Z_2 = 65$	$X_2 = 58$	$Y_2 = 44$
$Z_3 = 105$	$X_3 = 90$	$Y_3 = 68$

Distances in mm	2D min. code in mil	1D min. code in mil
40	4	2
65	5	3
105	10	5

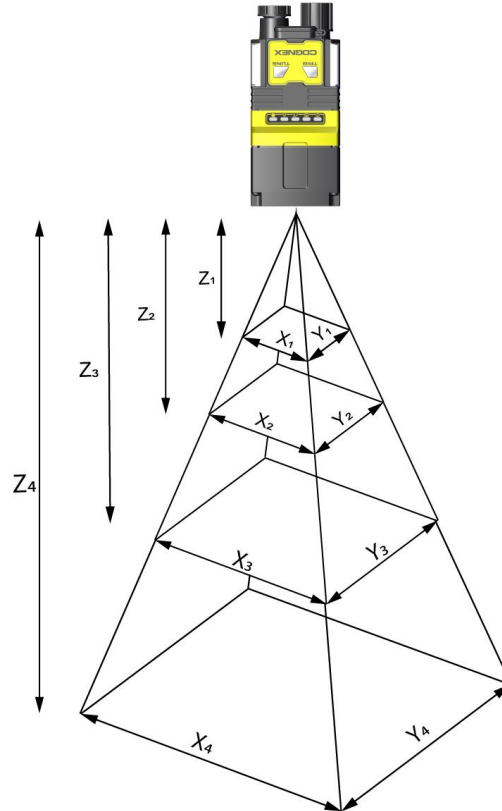

The following tables show the Field of View (FoV) widths of the 16 mm lens at various distances:

Working distance in mm	Horizontal values in mm	Vertical values in mm
$Z_1 = 150$	$X_1 = 46$	$Y_1 = 34$
$Z_2 = 225$	$X_2 = 69$	$Y_2 = 52$
$Z_3 = 375$	$X_3 = 116$	$Y_3 = 87$
$Z_4 = 1000$	$X_4 = 310$	$Y_4 = 232$

Distances in mm	2D min. code in mil	1D min. code in mil
80	2	2
150	3	2
190	4	3
225	5	3
375	8	5
500	10	7
1000	20	15

DataMan 300 and 360 Series Readers Reading Distances and Field of View

The DataMan 300 and 360 series readers: DataMan 300/360, DataMan 302/362, and DataMan 303/363 have different fields of view because of the different regions of the sensor used by each reader.

Scan Map for DataMan 300 and 360 Series Readers Using a 10.3 mm Lens

The map below shows the field of view of the DataMan 300/360, DataMan 302/362 and DataMan 303/363 readers with a 10.3 mm lens (with or without a liquid lens).

The FoV values are shown as follows:

- outer: DM302/362, DM303/363
- inner: DM300/360

The reading distances for the DM300/360 and DM302/362 readers are the same. The DM303/363 features a higher resolution and more pixels in about the same sensor size.

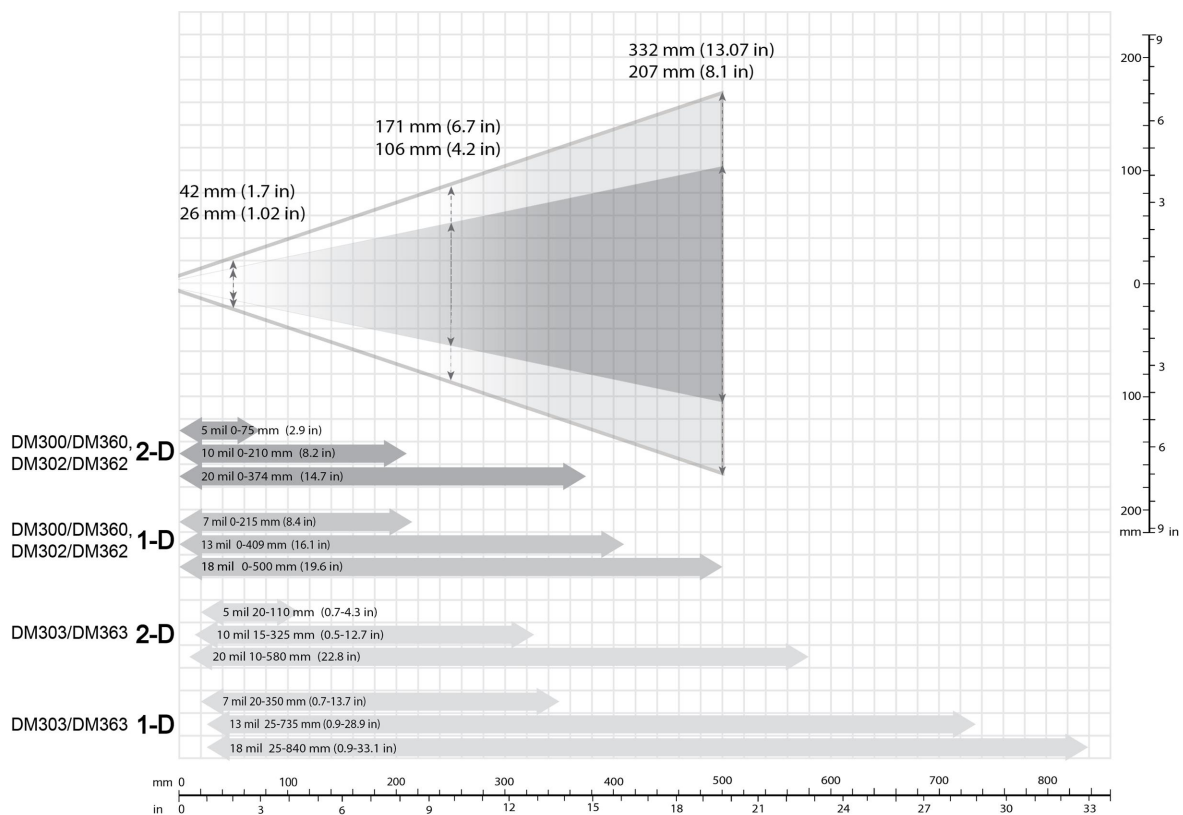

The following table shows the Field of View widths in mm at various distances.

Distances in mm	DM300, DM360	DM302/303, DM362/363
50	26	42
100	46	74

Distances in mm	DM300, DM360	DM302/303, DM362/363
150	66	106
250	106	171
500	207	332

Scan Map for DataMan 300 and 360 Series Readers Using a 16 mm Lens

This map shows the field of view of the DataMan 300/360, DataMan 302/362 and DataMan 303/363 readers with a 16 mm lens.

The FoV values are shown as follows:

- outer: DM302/362, DM303/363
- inner: DM300/360

The reading distances for the DM300/360 and DM302/362 readers are the same. The DM303/363 features a higher resolution and more pixels in about the same sensor size.

To make sure that your DM303/363 reader is able to decode at the minimum reading distances, use the reader in combination with the extension kit or without the front cover.

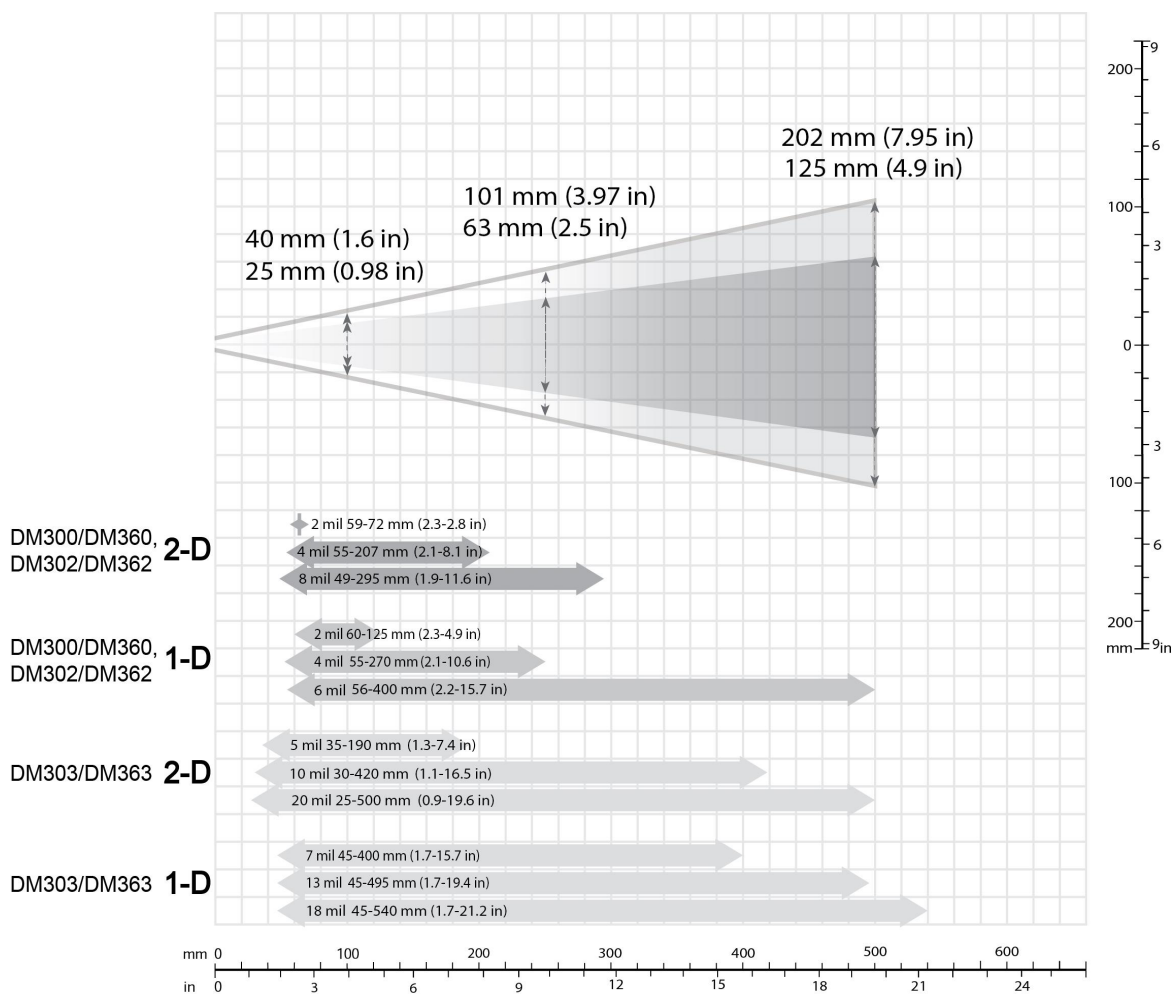

The following table shows the Field of View widths in mm at various distances.

Distances in mm	DM300, DM360	DM302/303, DM362/363
50	13	20
100	25	40
150	38	60
250	63	101
500	125	202

Scan Map for DataMan 300 and 360 Series Readers Using a 19 mm Lens

This map shows the field of view of the DataMan 300/360, DataMan 302/362 and DataMan 303/363 readers with a 19 mm lens (with or without a liquid lens).

The FoV values are shown as follows:

- outer: DM302/362, DM303/363
- inner: DM300/360

The reading distances for the DM300/360 and DM302/362 readers are the same. The DM303/363 features a higher resolution and more pixels in about the same sensor size.

To make sure that your DM303/363 reader is able to decode at the minimum reading distances, use the reader in combination with the extension kit or without the front cover.

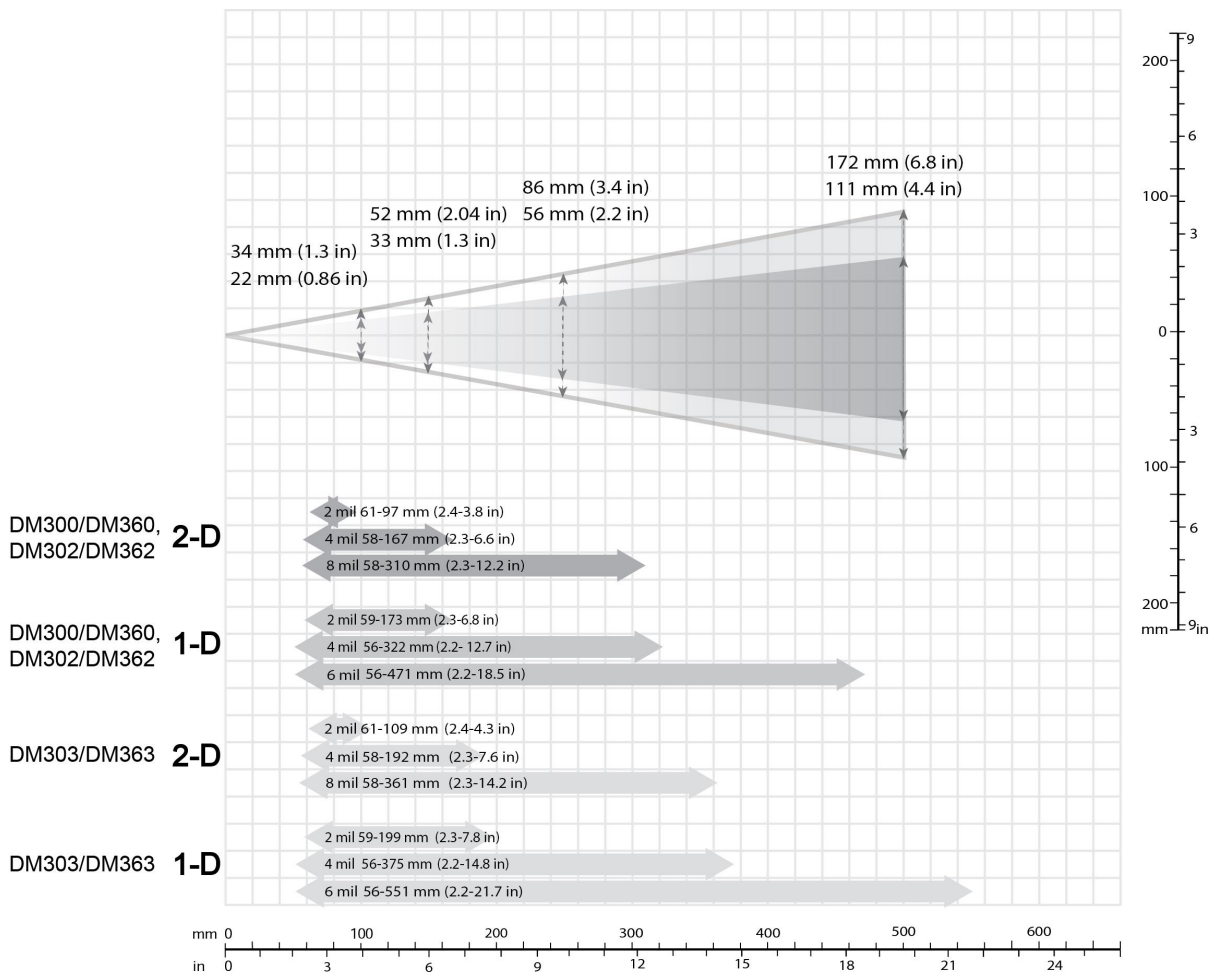

The following table shows the Field of View widths in mm at various distances.

Distances in mm	DM300, DM360	DM302/303, DM362/363
50	11	17
100	22	34
150	33	52
250	56	86
500	111	172

Scan Map for DataMan 300 and 360 Series Readers Using a 24 mm Lens with Liquid Lens

The maps in this section show the field of view of the DataMan 300/360, DataMan 302/362, and DataMan 303/363 readers with a 24 mm lens with a liquid lens and DM360-HPIL-RE-01 or DM360-HPIL-RE-P-01 cover.

The FoV values are shown as follows:

- outer: DM303/DM363
- middle: DM302/DM362
- inner: DM300/DM360

The reading distances for the DM300 and DM302 readers are the same. The DM303 and DM363 feature a higher resolution and more pixels in about the same sensor size.

The following table shows the FoV widths in mm at various distances.

Distances in mm	DM300	DM302/DM362	DM303/DM363
80	11	19	20
250	43	68	73
500	87	139	148
1000	175	281	298

Scan Map for the DataMan 300 Series Readers with a 24 mm Lens with Liquid Lens

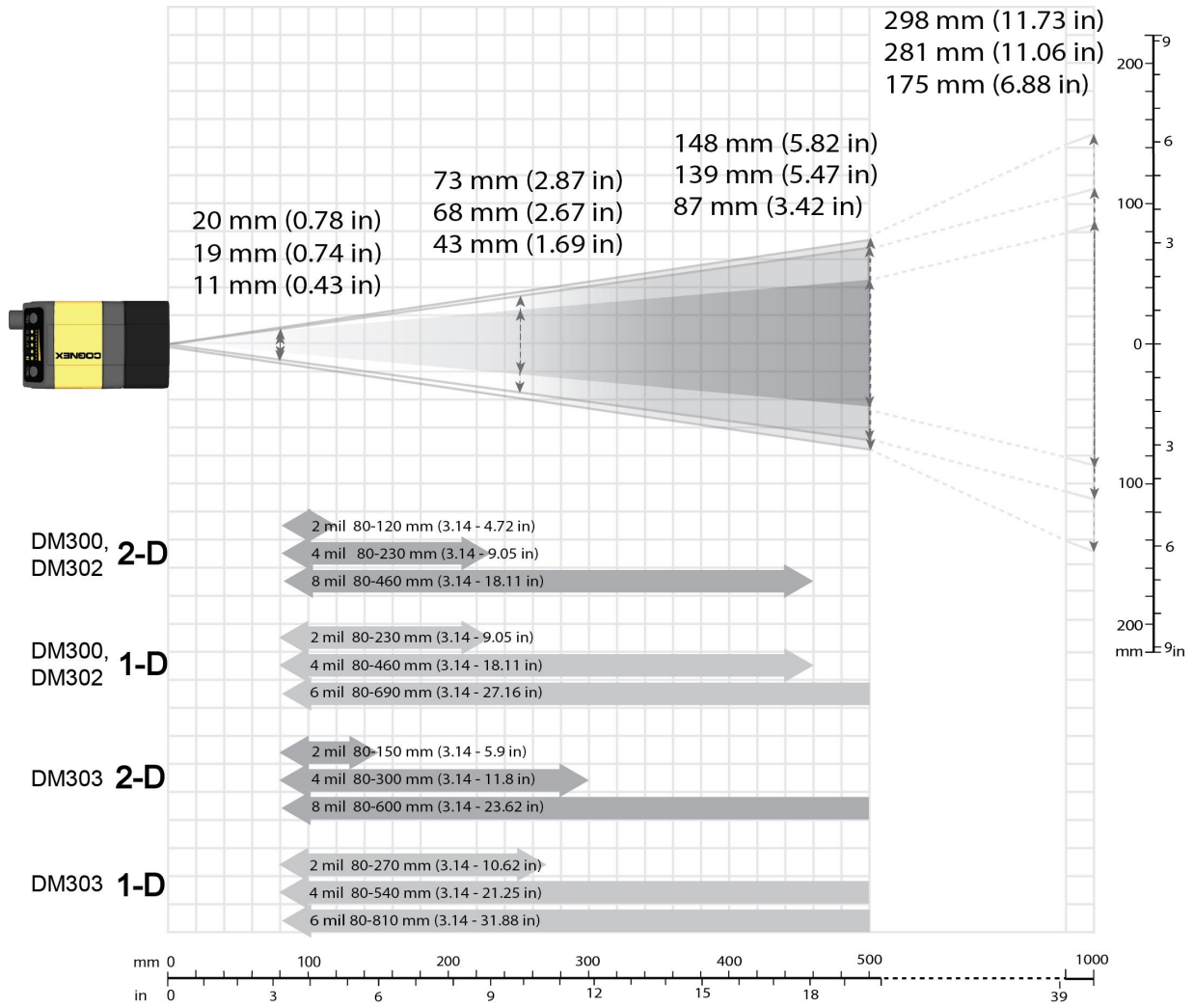

Scan Map for the DataMan 360 Series Readers with a 24 mm Lens with Liquid Lens

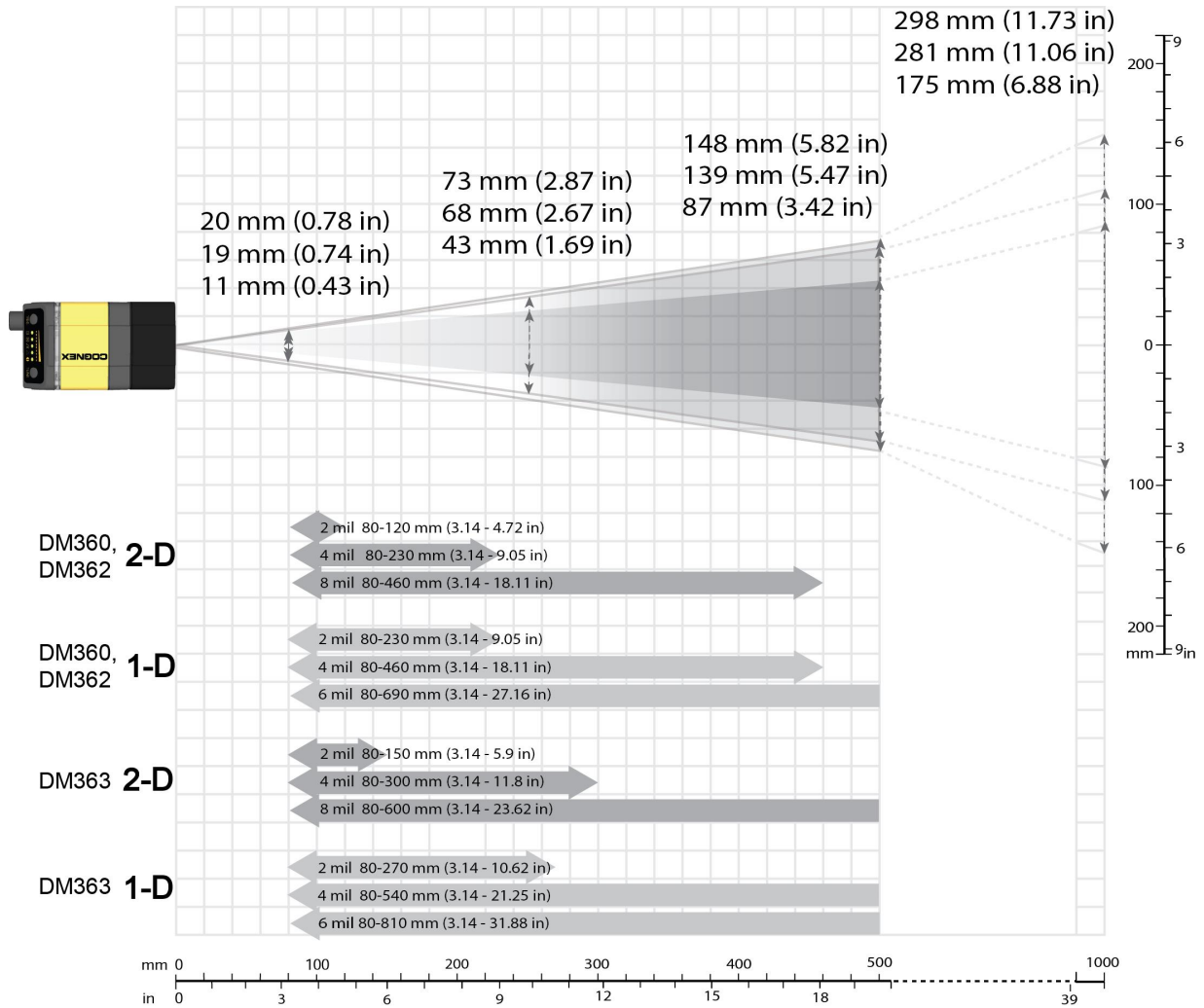

Scan Map for DataMan 300 and 360 Series Readers Using a 25 mm Lens

This map shows the field of view of the DataMan 300/360, DataMan 302/362, and DataMan 303/363 readers with a 25 mm lens.

The FoV values are shown as follows:

- outer: DM302/362, DM303/363
- inner: DM300/360

The reading distances for the DM300/360 and DM302/362 readers are the same. The DM303/363 features a higher resolution and more pixels in about the same sensor size.

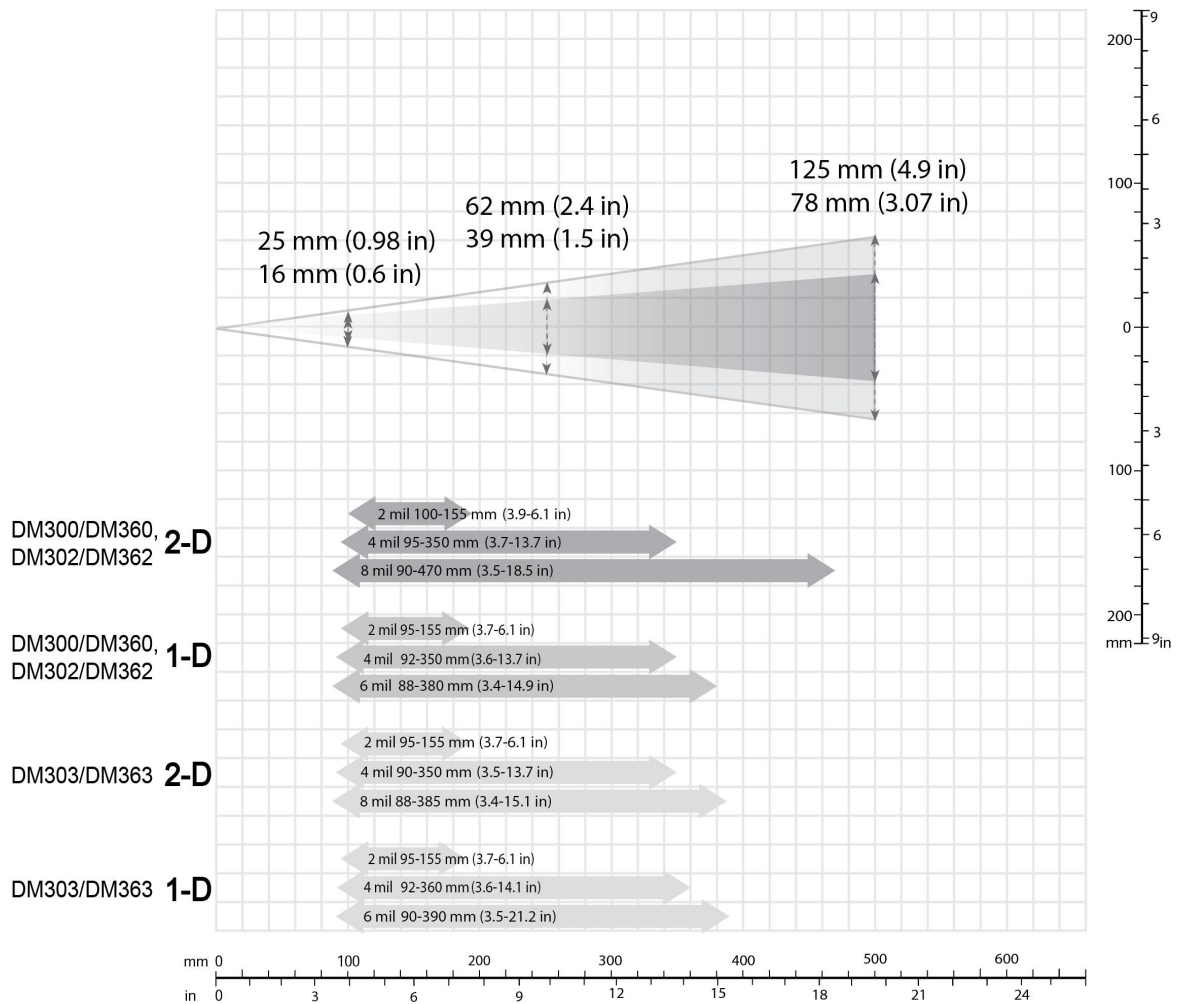

The following table shows the Field of View widths in mm at various distances.

Distances in mm	DM300, DM360	DM302/303, DM362/363
50	8	12
100	16	25
150	23	37
250	39	62
500	78	125

DataMan 370 Series Readers Reading Distances and Field of View

The following maps show the reading distance and field of view charts for the various lenses that can be used with the DataMan 370 series readers. Reading distance values are also provided for 1-D and 2-D example code distances.

Reading Distance and Field of View for DataMan 370 Series Readers with a 10 mm High-Speed Liquid Lens

Note: Due to tolerances, ranges can vary by +/- 5 % from unit to unit.

The following map shows the FoV of the DataMan 370 series readers with a 10 mm high-speed liquid lens.

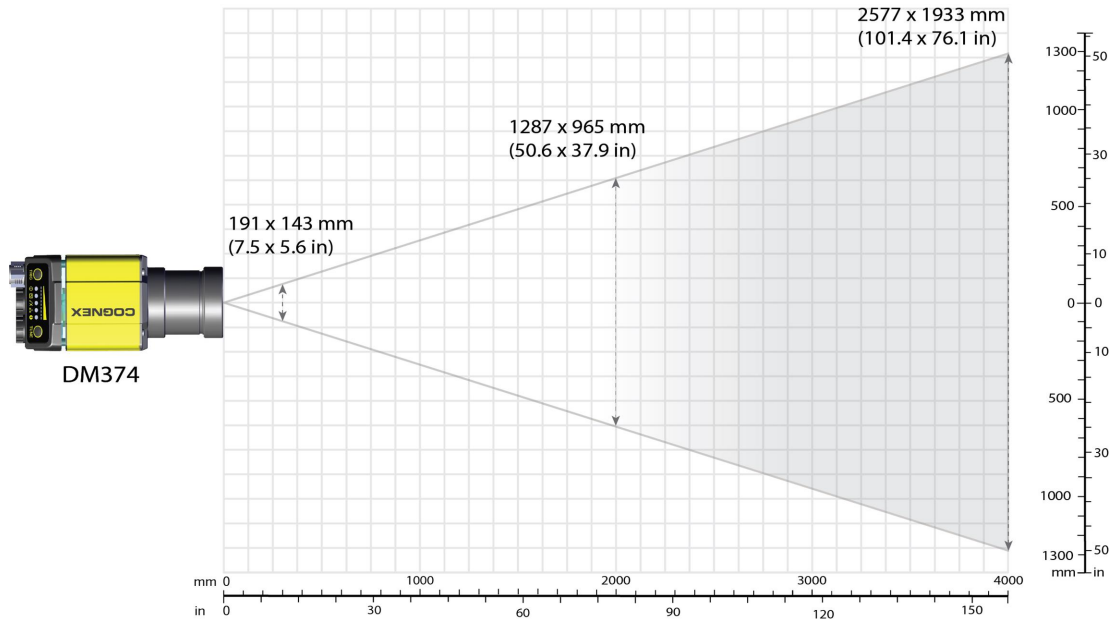

Device	Distances in mm / 1D min code 10 mm HSSL		Distances in mm / 2D min code 10 mm HSSL	
	DM37x	445	6 MIL	307
591		8 MIL	408	8 MIL
738		10 MIL	509	10 MIL
958		13 MIL	660	13 MIL
1104		15 MIL	761	15 MIL
1471		20 MIL	1013	20 MIL

Reading Distance and Field of View for DataMan 370 Series Readers with a 16 mm High-Speed Liquid Lens

Note: Due to tolerances, ranges can vary by +/- 5 % from unit to unit.

The following map shows the FoV of the DataMan 370 series readers with a 16 mm high-speed liquid lens.

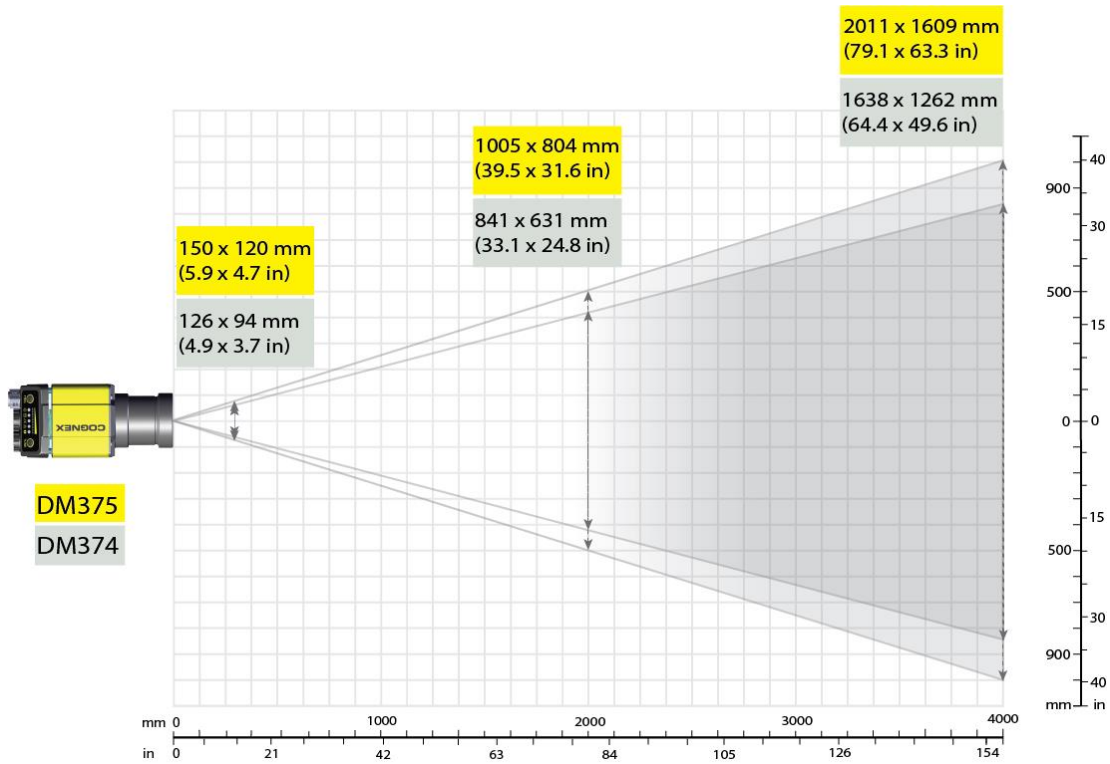

Device	Distances in mm / 1D min code 16 mm HSSL		Distances in mm / 2D min code 16 mm HSSL	
	DM37x	676	6 MIL	465
901		8 MIL	620	8 MIL
1125		10 MIL	774	10 MIL
1462		13 MIL	1006	13 MIL
1687		15 MIL	1160	15 MIL
2249		20 MIL	1547	20 MIL

Reading Distance and Field of View for DataMan 370 Series Readers with a 24 mm High-Speed Liquid Lens

Note: Due to tolerances, ranges can vary by +/- 5 % from unit to unit.

The following map shows the FoV of the DataMan 370 series readers with a 24 mm high-speed liquid lens.

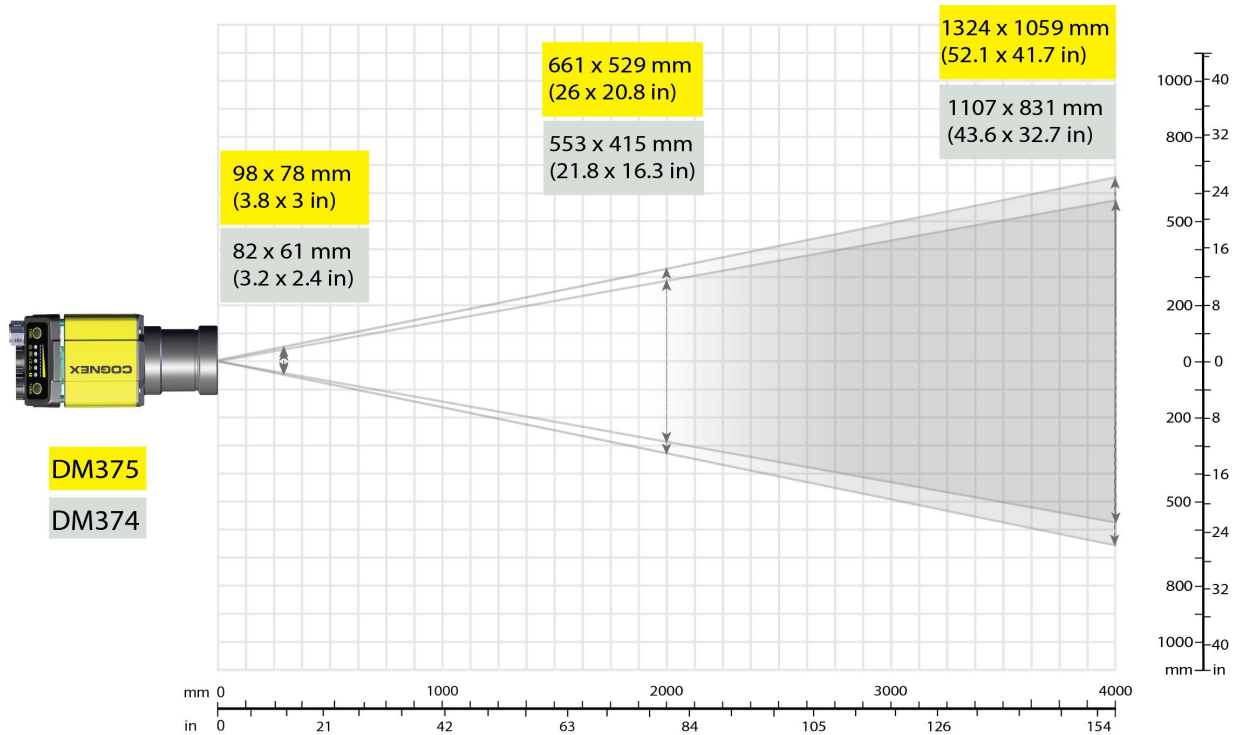

Device	Distances in mm / 1D min code 24 mm HSSL		Distances in mm / 2D min code 24 mm HSSL	
	DM37x	1029	6 MIL	709
1370		8 MIL	944	8 MIL
1711		10 MIL	1178	10 MIL
2223		13 MIL	1530	13 MIL
2564		15 MIL	1764	15 MIL
3417		20 MIL	2351	20 MIL

DataMan 470 Series Readers Reading Distances and Field of View

The following maps show the reading distance and field of view charts for the various lenses that can be used with the DataMan 470 series readers. Reading distance values are also provided for 1-D and 2-D example code distances.

Reading Distance and Field of View for DataMan 470 Series Readers with a 10 mm High-Speed Liquid Lens

Note: Due to tolerances, ranges can vary by +/- 5 % from unit to unit.

The map below shows the field of view (FoV) of the DataMan 470 series readers with a 10 mm high-speed liquid lens.

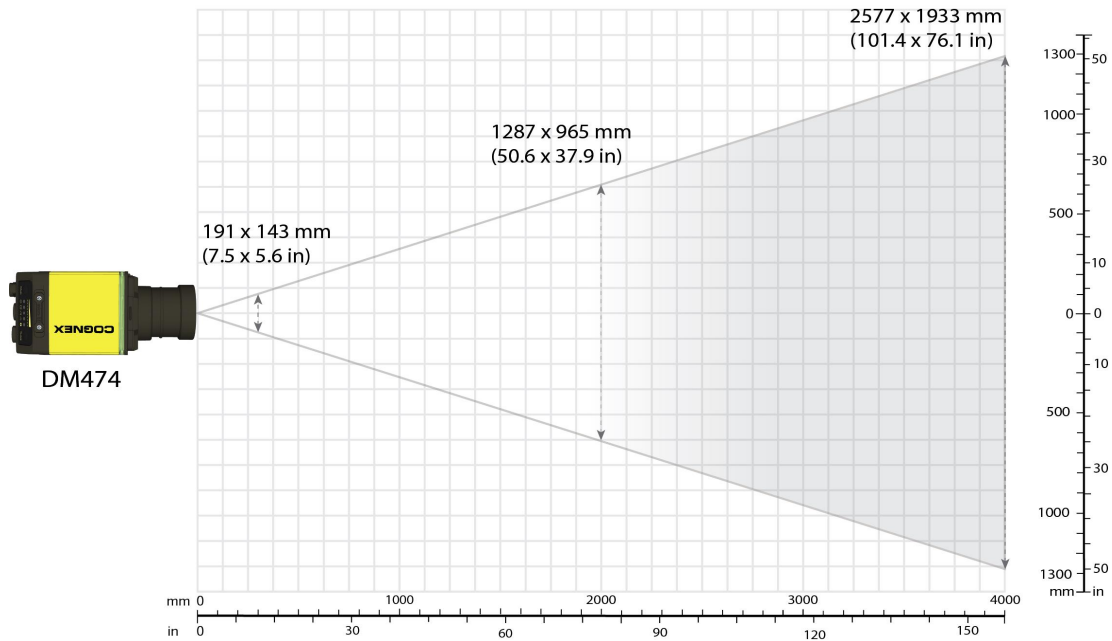

Device	Distances in mm / 1D min code 10 mm HSSL		Distances in mm / 2D min code 10 mm HSSL	
	DM47x	445	6 MIL	307
591		8 MIL	408	8 MIL
738		10 MIL	509	10 MIL
958		13 MIL	660	13 MIL
1104		15 MIL	761	15 MIL
1471		20 MIL	1013	20 MIL

Reading Distance and Field of View for DataMan 470 Series Readers with a 16 mm High-Speed Liquid Lens

Note: Due to tolerances, ranges can vary by +/- 5 % from unit to unit.

The following map shows the FoV of the DataMan 470 series readers with a 16 mm high-speed liquid lens.

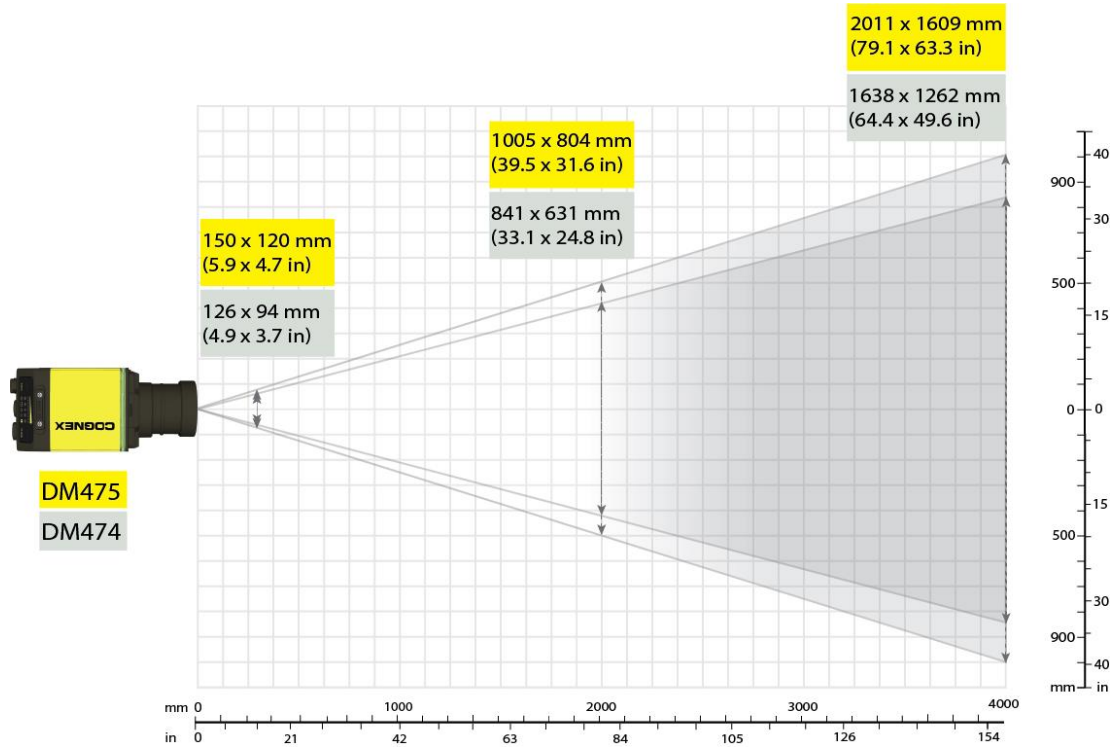

Device	Distances in mm / 1D min code 16 mm HSL		Distances in mm / 2D min code 16 mm HSL	
	DM47x	676	6 MIL	465
901		8 MIL	620	8 MIL
1125		10 MIL	774	10 MIL
1462		13 MIL	1006	13 MIL
1687		15 MIL	1160	15 MIL
2249		20 MIL	1547	20 MIL

Reading Distance and Field of View for DataMan 470 Series Readers with a 24 mm High-Speed Liquid Lens

Note: Due to tolerances, ranges can vary by +/- 5 % from unit to unit.

The following map shows the FoV of the DataMan 470 series readers with a 24 mm high-speed liquid lens.

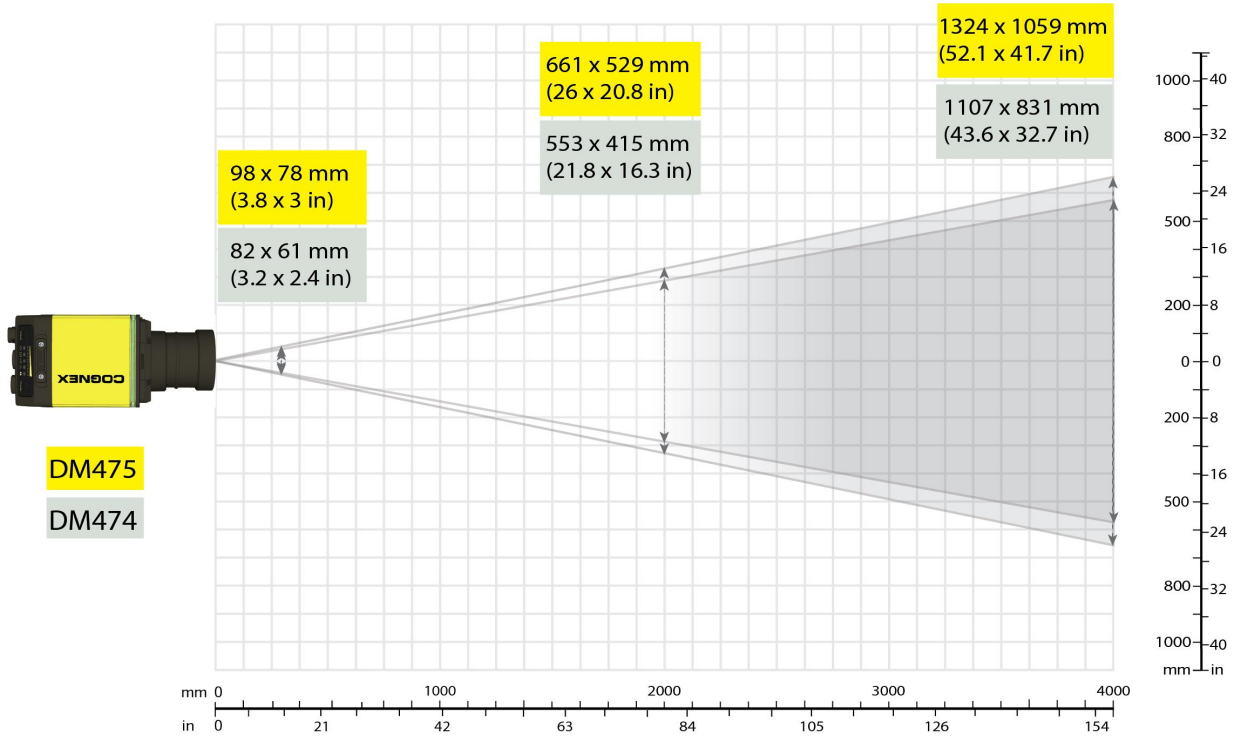

Device	Distances in mm / 1D min code 24 mm HSSL		Distances in mm / 2D min code 24 mm HSSL	
	DM47x	1029	6 MIL	709
1370		8 MIL	944	8 MIL
1711		10 MIL	1178	10 MIL
2223		13 MIL	1530	13 MIL
2564		15 MIL	1764	15 MIL
3417		20 MIL	2351	20 MIL

DataMan 503 Readers Reading Distances and Field of View

The following scan maps show the reading distance and field of view charts for the various lenses that can be used with the DataMan 503 reader.

Scan Map for DataMan 503 Series Readers Using a 16 mm Lens Module

The following map shows the reading distance and field of view charts for the DataMan 503 reader with a 16 mm lens for 1-D codes. The minimum 1-D resolution is at 1.2 pixels per module.

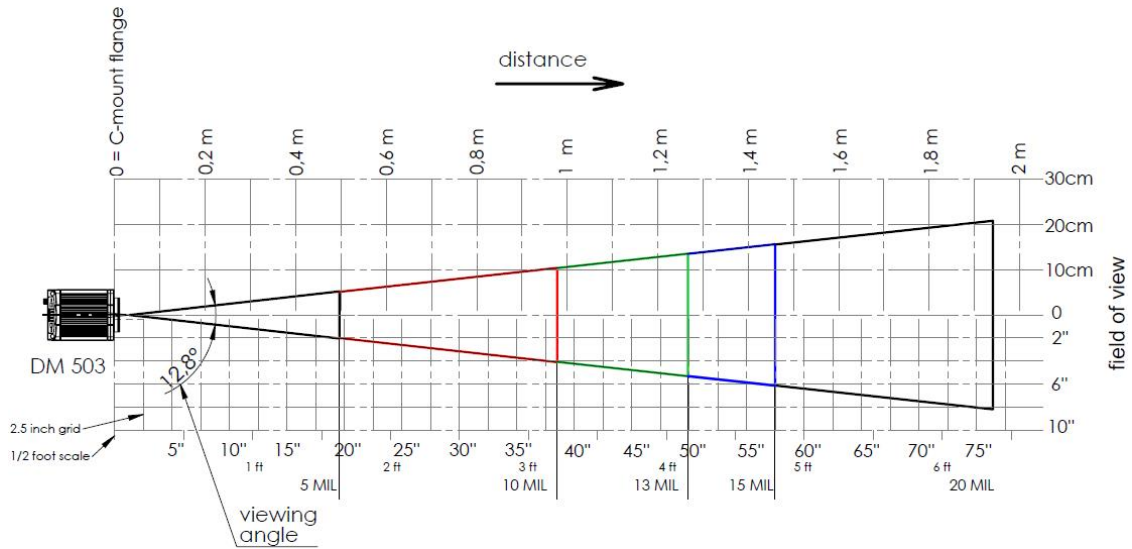

The following map shows the reading distance and field of view charts for the DataMan 503 reader with a 16 mm lens for 2-D codes. The minimum 2-D resolution is at 2.5 pixels per module.

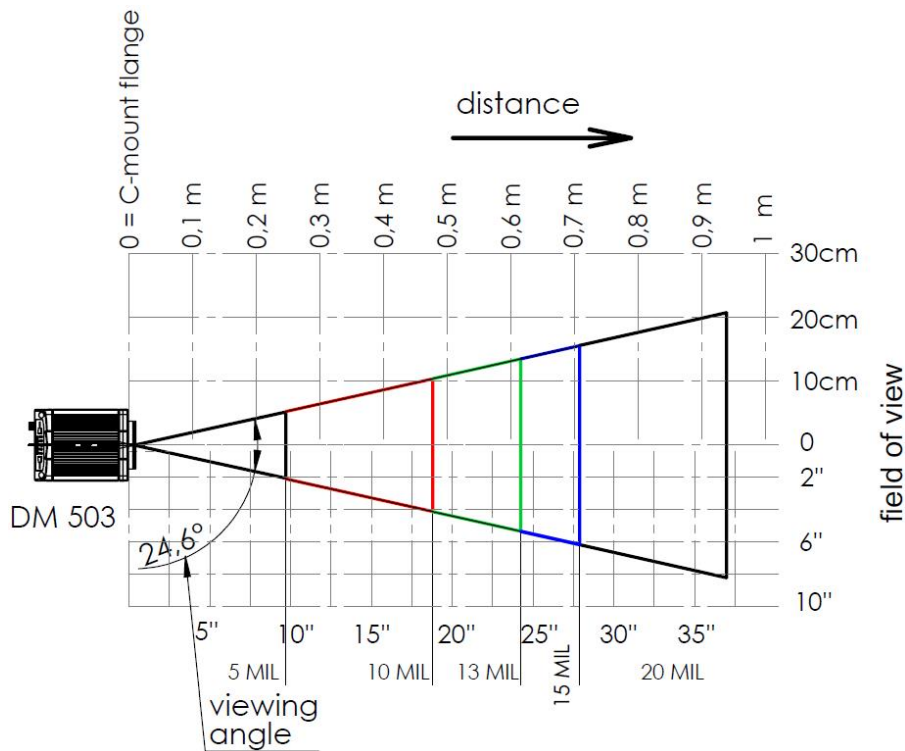

Scan Map for DataMan 503 Series Readers Using a 25 mm Lens Module

The following map shows the reading distance and field of view charts for the DataMan 503 reader with a 25 mm lens for 1-D codes. The minimum 1-D resolution is at 1.2 pixels per module.

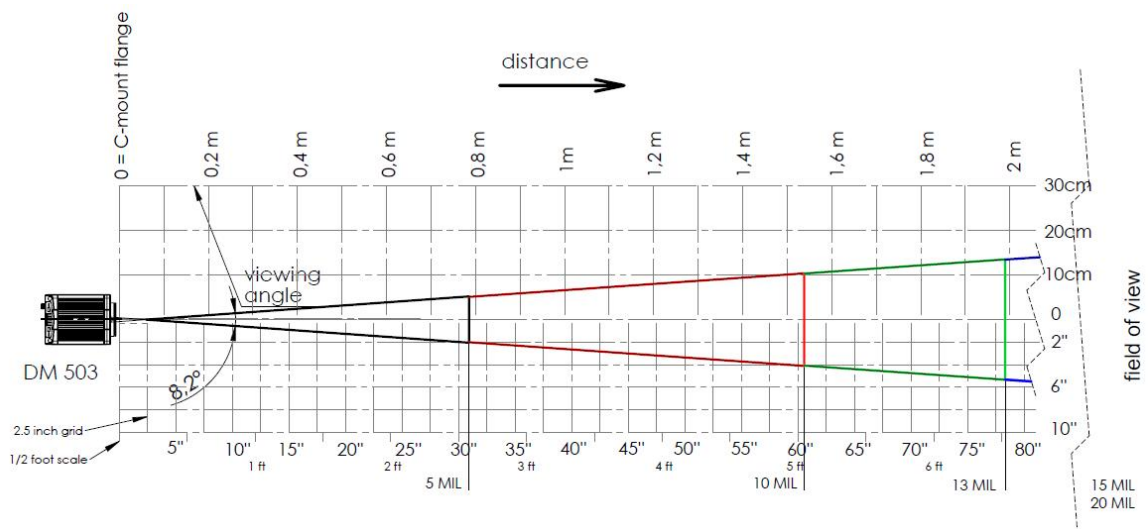

The following map shows the reading distance and field of view charts for the DataMan 503 reader with a 25 mm lens for 2-D codes. The minimum 2-D resolution is at 2.5 pixels per module.

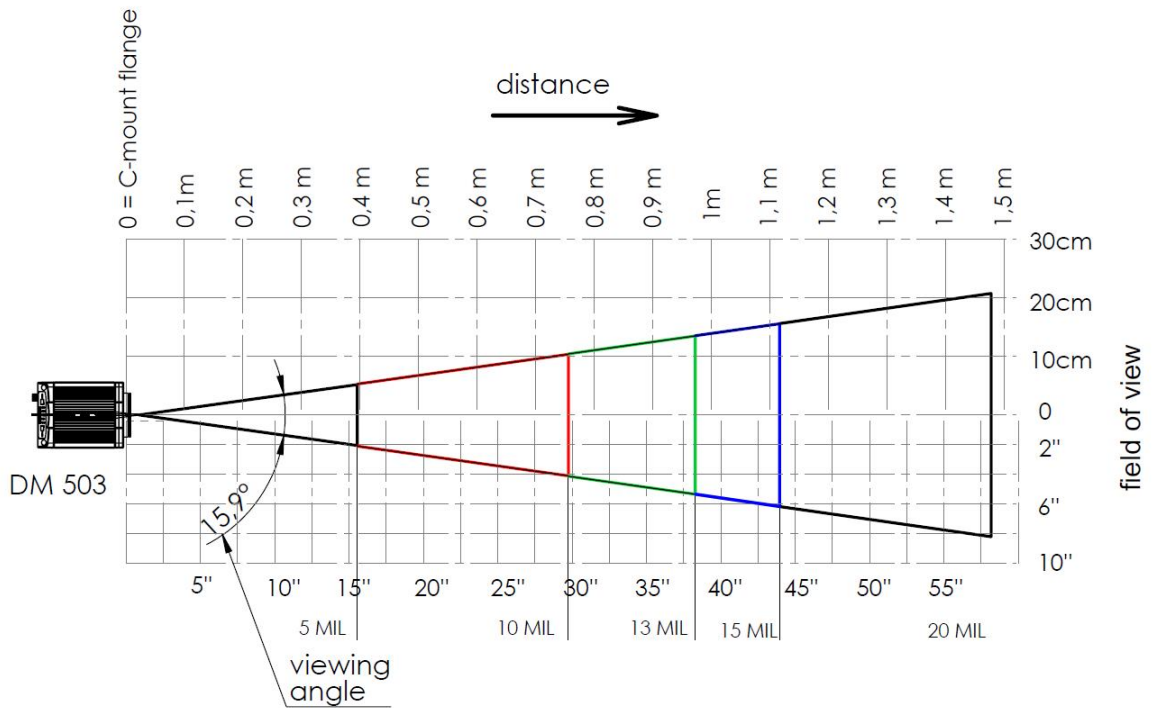

Scan Map for DataMan 503 Series Readers Using a 35 mm Lens Module

The following map shows the reading distance and field of view charts for the DataMan 503 reader with a 35 mm lens for 1-D codes. The minimum 1-D resolution is at 1.2 pixels per module.

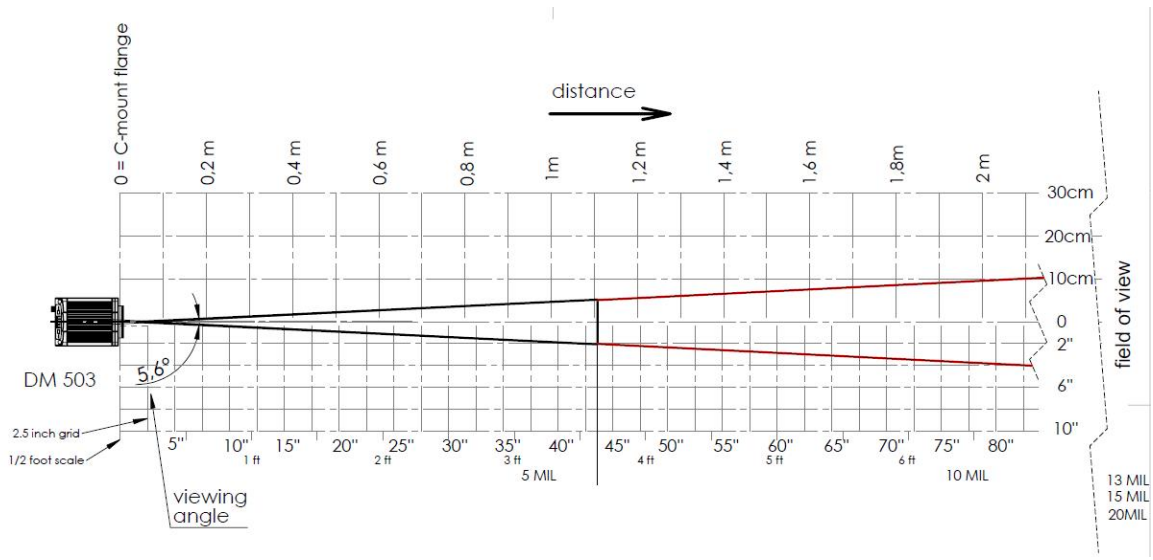

The following map shows the reading distance and field of view charts for the DataMan 503 reader with a 35 mm lens for 2-D codes. The minimum 2-D resolution is at 2.5 pixels per module.

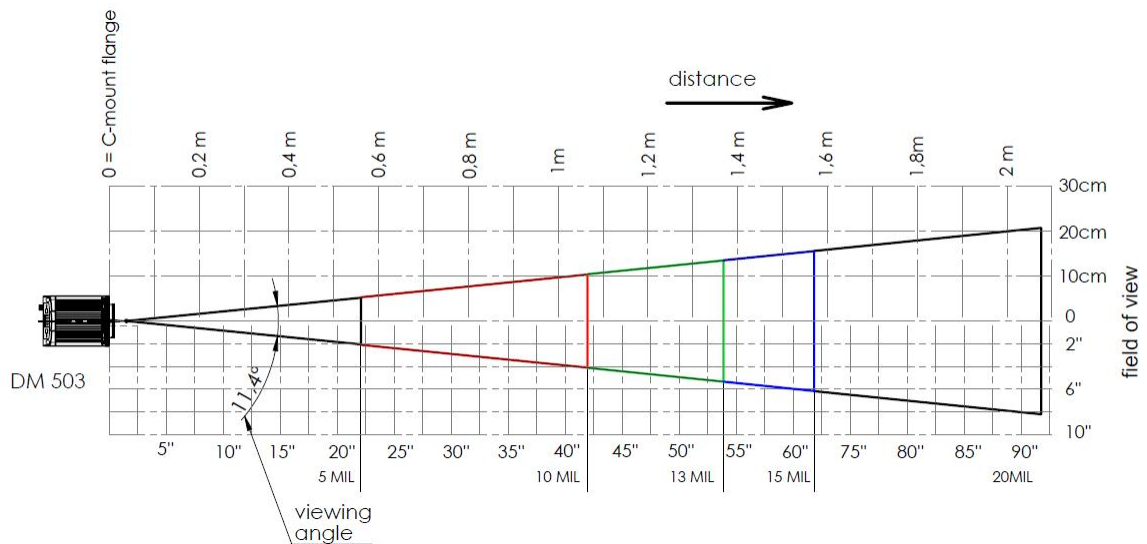

CS-Mount Lens Characteristics

This section provides information on using CS-mount lenses.

DataMan 503 CS-Mount Lens Characteristics

CS-mount lenses must meet the following requirements to be used with DataMan 503:

- No aspect of the lens may protrude past the end of the lens threads.
- The threads must be no more than 4 mm deep.
- The maximum size lens barrel that fits within the CS-mount lens cover is 30 mm long (measured from lens mount base) and 28 mm in diameter. You can remove the lens (and front) covers from DataMan to fit a larger lens, but the reader will not maintain its IP rating.

Internal Lighting

This section describes the working mechanism of the built-in lighting of DataMan 50, 60, 70, 150, 260, 503 and DataMan 300, 360, 370, and 470 series readers.

DataMan 50 and 60 Internal Lighting

All DataMan 50 and 60 readers include built-in (internal) lighting. During operation, the DataMan 50 and 60 automatically regulate image exposure time and imager gain to produce usable image quality at the highest possible frame rate.

As the working distance between the reader and code increases, additional light intensity or longer exposure times are required to maintain the same image quality. When the maximum illumination intensity is reached, the frame rate may be reduced to permit a longer exposure time.

DataMan 70, 150 and 260 Internal Lighting

All DataMan 70, 150 and 260 readers include built-in (internal) lighting. During operation, the DataMan 70, 150 and 260 automatically regulate image exposure time and imager gain to produce usable image quality at the highest possible frame rate.

As the working distance between the reader and code increases, additional light intensity or longer exposure times are required to maintain the same image quality. When the maximum illumination intensity is reached, the frame rate may be reduced to permit a longer exposure time.

DataMan 300, 360, 370, and 470 Series Readers Internal Lighting

The internal illumination module offers two rings of LEDs with four quadrants each. Each quadrant is controllable individually, that is, ON/OFF and intensity.

You can turn the quadrants ON or OFF by clicking on the dots (representing the LEDs) on the front image of the DataMan 300, 360, 370, or 470 in the DataMan Setup Tool's **Optimize Image** pane. The quadrants that are ON are displayed in red, as shown in the example below.



Tuning

By tuning, your DataMan 300, DataMan 360, DataMan 370, and DataMan 470 series reader automatically selects the best settings for the given reading situation, based on parameters of illumination, camera and decoder properties, and focal distance. Use this feature to create an optimum setting to read your DataMatrix codes.

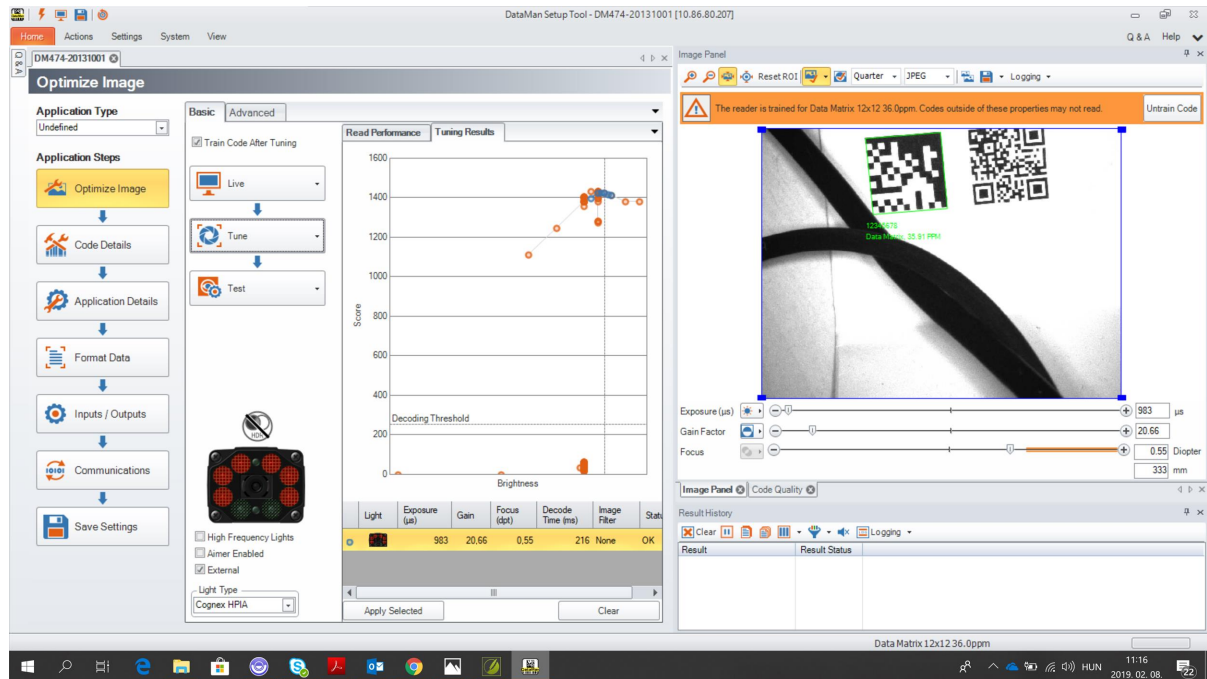

Note: Tune button can toggle the aimer light ON and OFF.

External Lighting

This section details the external lighting options for DataMan 50, 60, 503 and DataMan 300, 360, 370, and 470 series readers.

DataMan 50 and 60 External Lighting

The DataMan 50 and 60 readers have a dedicated output for external light control. In addition, the DataMan 60 has an external illumination connector on the front side of the reader.



external illumination connector

You can control the intensity output of the external illumination connector if the external illumination you use supports this control. In the DataMan Setup Tool, go to the **Optimize Image** pane and check the **External** checkbox. You can also choose your light type from the drop-down box below. In the **Optimize Image** pane's **Advanced** tab, you can make further external illumination settings.

DataMan 50 and 60 Illumination Strobe Output

The strobe output is provided by a diode that is added to the push-pull circuit, with series to the pull-up transistor. This diode blocks the higher voltage when the output is pulled up when used as open-collector type driving, but enables the driving of high level in TTL mode.

TTL output type characteristics	
High level	4.0-5.0 V
Low level	0-0.4 V
Output current	25 mA
Short-circuit current	125 mA
Short-circuit protection	multifuse – 50 mA

Open-collector output type characteristics	
Output voltage range	0-26 V
Low level	0-0.4 V
Output current	25 mA max
Short-circuit current	125 mA
Short-circuit protection	multifuse – 50 mA

The following figure shows the wiring diagram of the illumination strobe output.

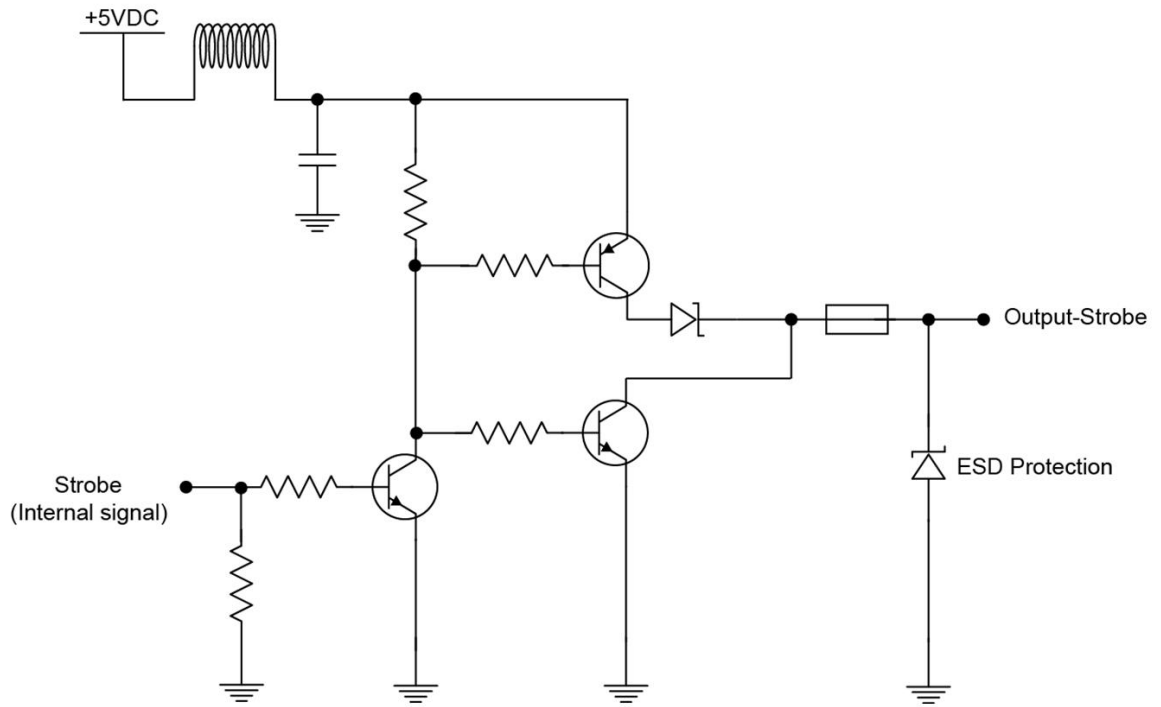

DataMan 50 and 60 External Load Strobe Output

The following image shows the external load strobe output for the DataMan 50. The DataMan 60 has the same characteristics.

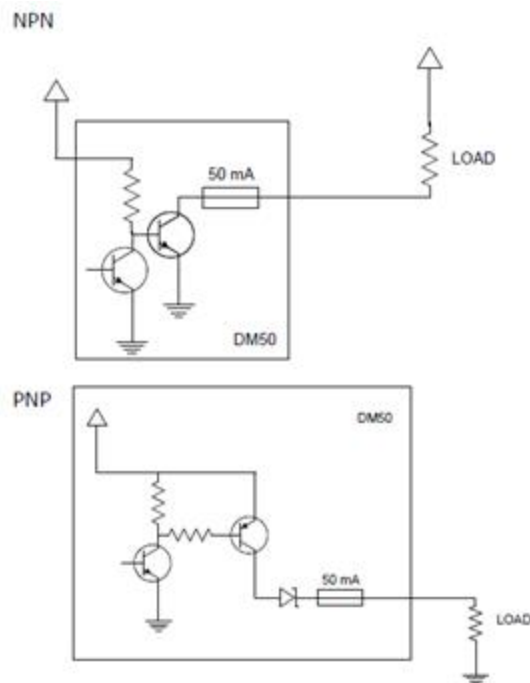

DataMan 300, 360, 370, and 470 Series Readers External Lighting

On the back of the reader, there is a socket dedicated to external light control (1, 2, 3, and 4 in the following image).

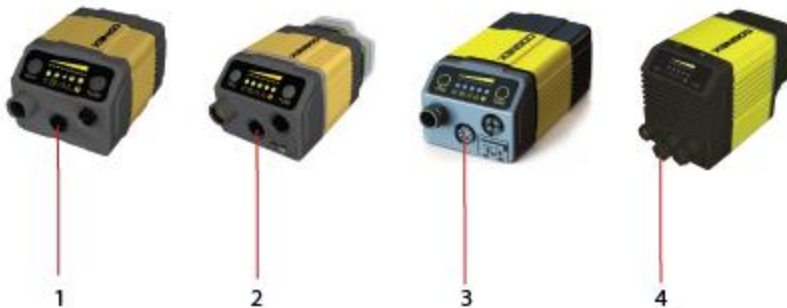

There are four mounting holes on the front of the reader to mount external illumination.

mounting holes for external illumination

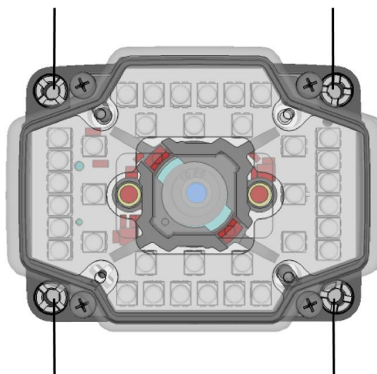

mounting holes for external illumination

You can control the intensity output of the external illumination connector if the external illumination you use supports this control. In the DataMan Setup Tool, go to the **Optimize Image** pane and check the **External** checkbox. You can also choose your light type from the drop-down box below. In the **Optimize Image** pane's **Advanced** tab, you can make further external illumination settings.

The DataMan 300, 360, 370, and 470 series readers support high power illumination accessories. For more information, see the Accessories sections in the *DataMan 300 Reference Manual*, the *DataMan 360 Reference Manual*, the *DataMan 370 Reference Manual*, and the *DataMan 470 Reference Manual*.

For detailed instructions on how to set the DataMan 370 and 470 series readers up with high power illumination accessories, see the following sections:

DataMan 370 series readers with High Power Integrated Light	Installing the Liquid Lens Module with High Power Integrated Light (HPIL) on page 58
DataMan 370 series readers with High Power Illumination Accessory	Installing a Lens with High Power Illumination Accessory (HPIA) on page 62
DataMan 370 series readers with High Power Integrated Torch (HPIT)	Installing High Power Integrated Torch (HPIT) on page 64
DataMan 470 series readers with High Power Integrated Light	Installing the Liquid Lens Module with High Power Integrated Light (HPIL) on page 58
DataMan 470 series readers with High Power Illumination Accessory	Installing a Lens with High Power Illumination Accessory (HPIA) on page 1
DataMan 470 series readers with High Power Integrated Torch (HPIT)	Installing High Power Integrated Torch (HPIT) on page 64

External Light Mounting Brackets

You can mount your reader using external light mounting brackets. The brackets are intended to mount any of the different lights to the reader. They can also be used to mount the reader (with lights attached) to your machine. Pivot mounting, as illustrated, is optional. Perform the following steps:



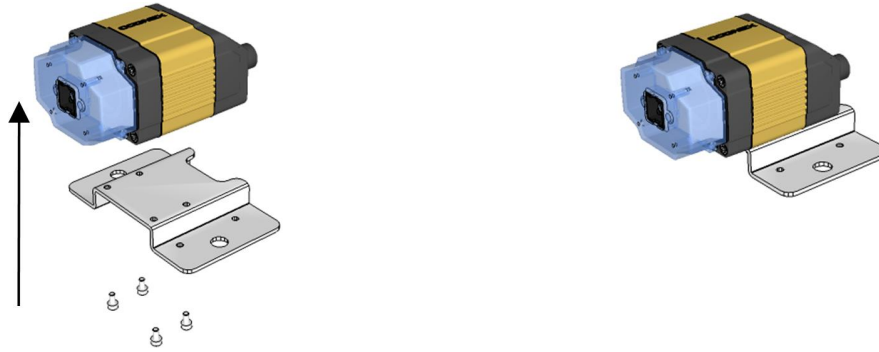

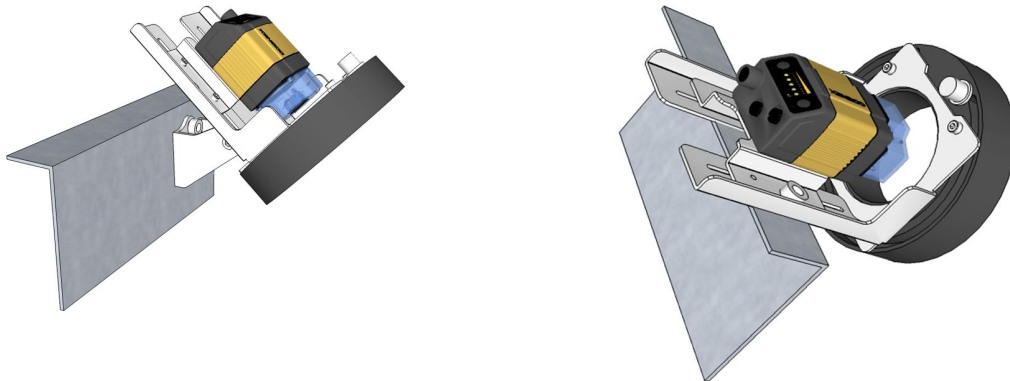

1. Mount your reader on the camera plate and attach the screws.



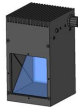

2. Mount your reader with the camera plate attached to any of the external light bracket adapters.



Choose one of the following external light options:

Accessory		
Ring Light	CLRR-R7030G1CLR	
Back Light	CLRB-F100100G1	
Coaxial (DOAL) Light	CLRO-K5050G1	
Spot Light	CLRS-P14G1	
Dark-field Light	CLRD-D120G1	
Brick Light	IVSL-ODDM-S75-xxx	

Accessory		
Bar Light	IVSL-YLW2X-xxx	
Bar Light	IVSL-LX520-xxx	
LX280-series Light	IVSL-LX280-xxx	

DataMan 50, 60, 300, 360, 370, and 470 External Lighting Duration

In all cases, as soon as the trigger is detected, external illumination is turned on. There is a 600 μ Sec pre-charge time before exposure starts; the lighting is on during this period. In the DataMan Setup Tool's **Optimize Image** pane, you can click the **Tune** button's drop-down icon and from the **Optimize Brightness** section select Automatic Exposure (autoregulation) or Manual Exposure (non-autoregulation) according to your needs. You can also reach the same settings by navigating to the Setup Tool's **Applicaton Details** pane.

If you use a DataMan 302 reader with full Field of View (FoV), consider the following:

- In non-autoregulation cases, exposure occurs for an amount of time you specify. You can configure this time in the DataMan Setup Tool's **Application Details** pane. When exposure ends, illumination is turned off. Altogether, the exposure duration equals the exposure time you set and the 600 μ Sec pre-charge time.
- If autoregulation is enabled, the duration can vary depending on the maximum allowed exposure value configured and the computed exposure time (which will be different for each acquisition). To calculate a "worst case" duration, set a maximum exposure value, and the longest the lights will be on is

600 uSec precharge time + max exposure time

Exposure occurs for the amount of time determined by autoregulation. When exposure ends, illumination is turned off. If you use a reduced FoV for a DataMan 50, 60, 300, 360, 370, or 470 reader, the image transfer time will scale proportionally to the FoV/Sensor size.

DataMan 503 External Lighting Duration

In all cases, as soon as the trigger is detected, external illumination is turned on. There is a user adjustable μ Sec pre-charge time before exposure starts; the lighting is on during this period. In the DataMan Setup Tool's **Application Details** pane, you can select Automatic Exposure (autoregulation) or Manual Exposure (non-autoregulation) according to your needs.

- In non-autoregulation cases, exposure occurs for an amount of time you specify. You can configure this time in the DataMan Setup Tool's **Application Details** pane. When exposure ends, illumination is turned off. Altogether, the exposure duration equals the exposure time you set, the adjustable μ Sec pre-charge time, plus a maximum 17,15 ms image transfer time.
- If autoregulation is enabled, the duration can vary depending on the maximum allowed exposure value configured and the computed exposure time (which will be different for each acquisition). To calculate a "worst case" duration, set a maximum exposure value, and the longest the lights will be on is

Max. allowed precharge time + max exposure time

Exposure occurs for the amount of time determined by autoregulation. When exposure ends, illumination is turned off.

Operations Guide

This section contains information about configuring and using your DataMan reader.

Trigger Modes

The fixed-mount DataMan readers provide the following trigger modes:

Self-Trigger

DataMan fixed-mount readers support *self-triggered* operation. In self-trigger mode, the reader automatically detects and decodes codes in its field of view. The high-speed image acquisition and processing capabilities of the DataMan allow it to detect *and decode* codes.

Self-trigger mode has the following characteristics:

- Ease of setup. No external trigger is required.
- Flexible timing. Parts can arrive at irregular intervals.
- Maximum throughput.

Manual

Manual triggering starts acquiring and attempting to decode images when you send an external trigger. The reader continues to acquire and attempt to decode images until you stop the external triggering. 2-D DPM codes are automatically learned.

Manual trigger mode is typically used during debugging or system design.

Burst

Burst triggering acquires a pre-defined number of images when an external trigger is signaled, then attempts to decode the acquired images. You can control the interval between the acquired images. The number of images acquired per burst depends on the size of the region of interest that you specify.

Continuous

Continuous triggering begins acquiring images based on a single external trigger and continues to acquire and decode images at a user-specified interval until a symbol is found, or until multiple images containing as many codes as specified in multicode mode are located. The external trigger can be configured as a latch (acquisition continues while the line is held high) or acquisition can be started on the first pulse, stopped on the second pulse. If you scan items on a conveyor, make sure that each item reaches trigger OFF before the next item generates trigger ON.

Single

Single triggering acquires a single image and attempts to decode any symbol it contains, or more than one symbol in cases where multicode is enabled. The reader relies on an external trigger source.

Presentation

Presentation triggering repeatedly scans for a symbol and decodes it whenever one is detected. The reader relies on an internal timing mechanism to acquire images.

Presentation mode is similar to manual trigger mode, without using the trigger as a signal to start acquisition.

Package Detection Support

You can connect your package detection sensor to one of the digital inputs of your DataMan reader. When the reader receives a signal that a package is detected, images that the reader collected are not discarded at the end of the trigger. This way you can make sure that there was a package there, only the code was not readable. Looking at the No Read images will help you find out why there was no decode results.

Package detection is only supported with Continuous trigger mode. Continuous (external) trigger mode means that the trigger stops if the event generating the trigger stopped, or if there is a good read. Until the trigger stops, the reader collects images. These are No Read images (otherwise the trigger would stop).

You can use this feature in a stand-alone configuration, or in a multi-reader sync configuration. In the latter case, connect the sensor to the Primary reader. The Primary reader will initiate a request to save images and collect the images from the secondary readers.

To make sure that the No Read images are collected, perform the following:

1. Connect your package detection device to one of the Inputs of your reader.
2. In the DataMan Setup Tool's **Inputs/Outputs** pane's **Inputs** tab, check **Allow Buffered No-Read Images** on the input you connected your reader to.
3. In the **Inputs/Outputs** pane, click the **Buffering and Transfer** link next to or above the tabs. This directs you to the **Buffering and Transfer** pane. On the **Image Buffering** tab, change **What Results to Buffer** to **All**, or **No Read**.
 - In the case of **All**, good reads are also saved together with No Reads.
 - In the case of **No Read**, the image is buffered if the reader fails to read.

The following diagram shows the working mechanism:

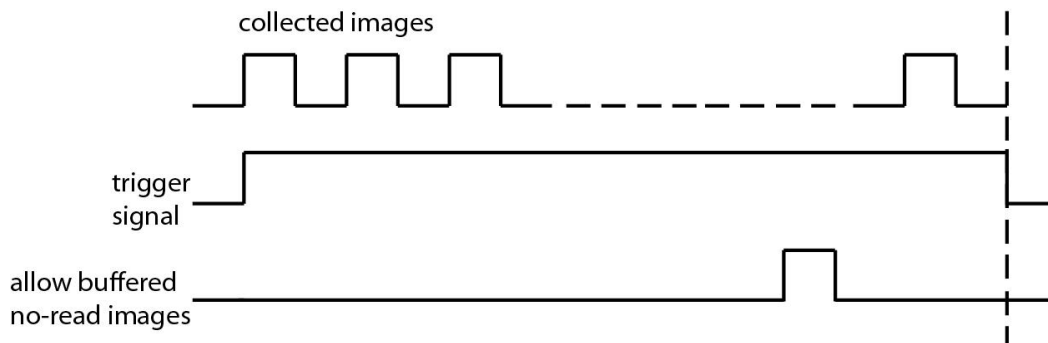

The signal from the sensor tells the reader not to discard the collected images at the end of the trigger event.

Test Mode

Test mode lets you configure and test a reader that is connected to a production line without needing to slow down or stop your line. To enter **Test mode**,

- Press the button (to which you previously assigned this function) on the device for 3 seconds
- Send a DataMan Control Command (DMCC)
- Click the Test Mode button in the DataMan Setup Tool

While in test mode, the reader, by default, ignores all external trigger sources and disables all input and output lines. Test mode provides two ways for you to test your reader configuration:

- Check **Automatic Triggering**, and the reader will simulate external triggers at the interval that you specify. This allows you to examine the result of each trigger and images with the configuration used in production but at a slower rate. Because inputs and outputs are disabled, the reader will not interfere with the normal operation of your line.
- If you click **Accept Trigger Batch**, the reader will accept and process a limited number of external triggers (you can specify the number) at production speed. You can then examine these results and corresponding images to verify how the reader is processing triggers in production.

If needed, you can enable both inputs and outputs during test mode, but you may encounter I/O process latencies.

Code Training

You can train the DataMan fixed-mount readers for single or multiple codes. Training can improve performance, since the reader does not have to determine code parameters as it reads the codes.

Code training is only supported for the following trigger modes:

- Burst
- Continuous
- Self (internal trigger)
- Single (external trigger)

You can train codes in the following ways:

- In the DataMan Setup Tool's **Optimize Image** pane, check the **Train Code After Tuning** checkbox and tune your reader. In the Image Panel on the right, you will see a message such as in the following image:

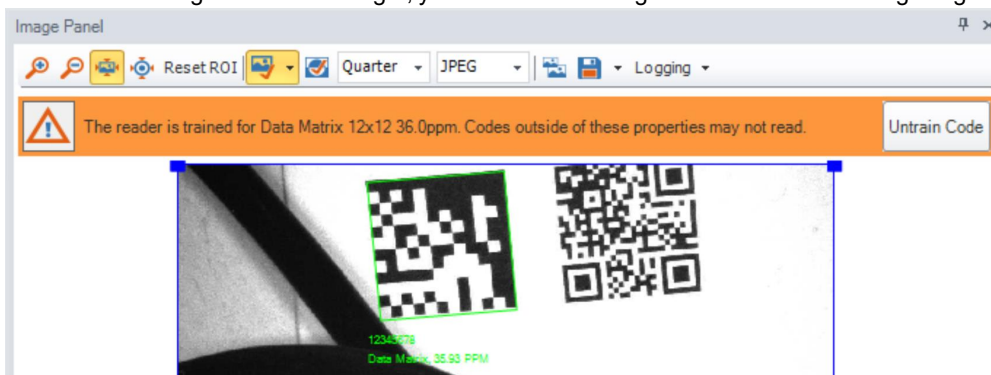

For further code training settings in the Setup Tool, go to the **Code Details** pane's **Advanced** tab.

- Use the **TRIG Button** tab in the **Inputs/Outputs** pane to configure the button to train codes, then present the codes to the reader and press and hold the button for 3 seconds.
- Use the **Inputs** tab in the **Inputs/Outputs** pane to configure a discrete input to perform code training.

Automatic Code Training for DPM Symbols

Manual and Presentation modes automatically train 2-D symbols. This improves robustness on DPM symbologies when reading consecutive parts of the same type. Sequential dissimilar parts will still decode.

Image Buffering and Image Recording

You can configure the DataMan fixed-mount readers to store selected images in the memory of the reader.

You can select the following options on which images to store:

- No images.
- No-read images. (Images where the reader was triggered but either no code was present or the code could not be decoded.)
- Images where a code was successfully decoded.
- All images.

If you select all images or no-read images, you can specify a sampling rate to control the number of images that are buffered.

Retrieving Buffered Images

You can use the DataMan Setup Tool to view and download images from your DataMan device, or you can configure the DataMan reader to automatically transfer the buffered images to an FTP server that you specify.

For more information, see the *DataMan Setup Tool Reference Manual*.

DataMan Multi-Reader Sync Configuration

Overview

If you have multiple DataMan fixed-mount readers connected to the same network, you can configure multiple readers to use group triggering. Readers configured to use group triggering all acquire an image simultaneously, and then combine their individual read results to form a composite result.

There are two important aspects to group triggering:

- Readers configured for group triggering consolidate reader results from among all readers in the group and transmit them from the primary reader only. This simplifies the task of collecting and processing read results from multiple readers.
- Readers configured for group triggering can be triggered simultaneously based on a single input trigger signal received by the primary reader.

Multi-Reader Sync configurations are typically used to expand the field of view for broad conveyor applications and to read codes from multiple surfaces of packages or objects:

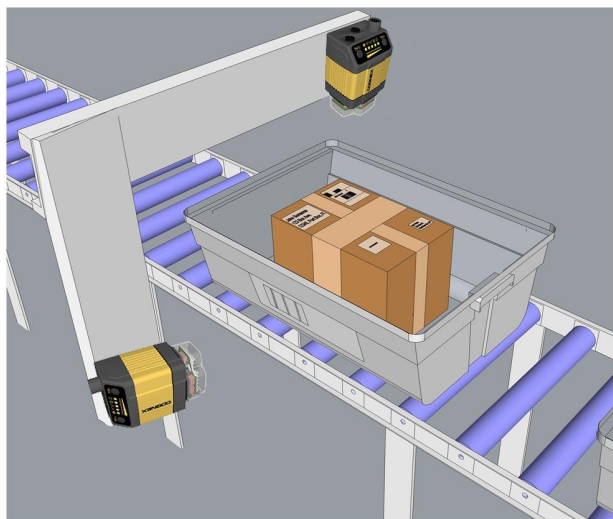
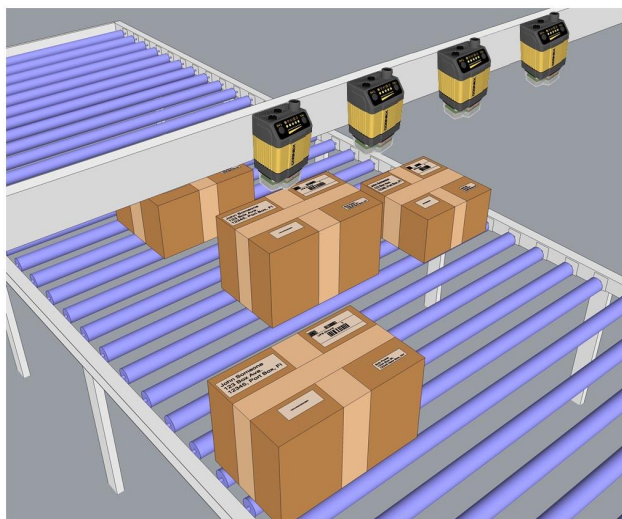

Primary Reader

Within a group, one reader is defined as the primary reader. When the primary reader is triggered (regardless of what type of trigger it uses), all the readers in the group are also triggered. For self-trigger mode, you must designate the primary reader explicitly. For externally triggered modes (single, burst, and continuous), whichever reader receives the trigger is designated the primary reader for that acquisition. (In most cases, only a single reader in the group will be connected to the external trigger.)

To account for network latency, you specify a trigger delay for the primary reader in the group. When the primary reader is triggered, it immediately sends triggers to the other group members, but delays its own acquisition for the specified delay, allowing the trigger signal to reach the other readers. You can also configure a separate trigger timeout, which will cause the primary reader to wait for a specified period of time for secondary readers to send data before collecting the results and transmitting them.

After a read attempt, only the primary reader transmits a result. It combines all of the available results from the other readers in the group in the same way that multicode results are combined.

Secondary Readers

In many applications, the multi-reader sync configuration is set to trigger the secondary readers whenever the primary reader is triggered. If the secondary readers are configured for Self triggering, then they will also trigger whenever they detect a code. In this case, the primary reader will generate and transmit a read result whenever any reader detects a code. This result aggregation greatly simplifies multiple reader operation.

Data Formatting

When the reader is triggered, the result string will be formatted as you specified, before it is transmitted to the primary reader for aggregation. Note, however, that you have to check Standard Formatting Enabled for the primary reader and supply the formatting tokens you want to use for the secondary readers. Any data formatting that you specify for the primary reader will be applied to the formatted result strings produced by the secondary readers. The **Format Data** pane includes a token that allows you to insert the name of the reader generating the result string; you can use this to identify which reader produced which result.

Limitations

- No image buffering and recording is supported for any reader that is part of a group.
- Presentation mode triggering is not supported.
- Multi-Reader Sync triggering only works correctly if the Primary and the Secondary readers use specific, allowed combinations of trigger modes. They are the following:
 - Self/Self
 - Single/Burst, Single/Single, Burst/Burst, Burst/Single
 - Manual/Continuous, Manual/Manual, Continuous/Continuous, Continuous/Manual

Synchronized Acquisition

Synchronized Acquisition is only available for the DataMan 300, 360, 370, and 470 readers with an -M option, and the DataMan 503. In Single, Burst, Continuous, and Self trigger modes, it is possible to synchronize image acquisition on multiple devices using the synchronization interface.

Synchronization allows using one shared strobe illumination to expose all sensors simultaneously. You can synchronize multiple readers, with optionally triggering them in a defined sequence to avoid that opposing readers blind each other.

Note: PTP synchronization and other imager settings do not get synchronized by this mechanism - for example, you have to configure exposure and gain on each reader individually.

This feature only synchronizes the actual image acquisition, triggering happens through the existing multi-reader sync mechanism.

Synchronized Acquisition for the DataMan 300, 360, 370, and 470

To set up synchronized acquisition on your reader, enable PTP (Precision Time Protocol) on the Multi-Reader Sync pane of the DataMan Setup Tool under Synchronized Readers (IE1588).

Perform the following steps:

1. Check **Enable PTP**.
2. Keep **Secondary Camera Only** checked if there is already a PTP Primary Reader clock in the network (uncheck the checkbox otherwise on at least one reader).
3. Enable **MRS Synchronized by PTP** to synchronize Multi-Reader Sync triggering.
4. Set the **Time between Trigger Start and the Synchronized Acquisition Timestamp**. This is the time the Primary Reader adds to the trigger to make sure all devices already received the trigger message before this time stamp (Primary Reader Only).
5. Set the **Local Offset Added to the Synchronized Acquisition Timestamp**. This is the time the Secondary Reader adds to the timestamp to realize offset image acquisitions (Secondary Reader Only).

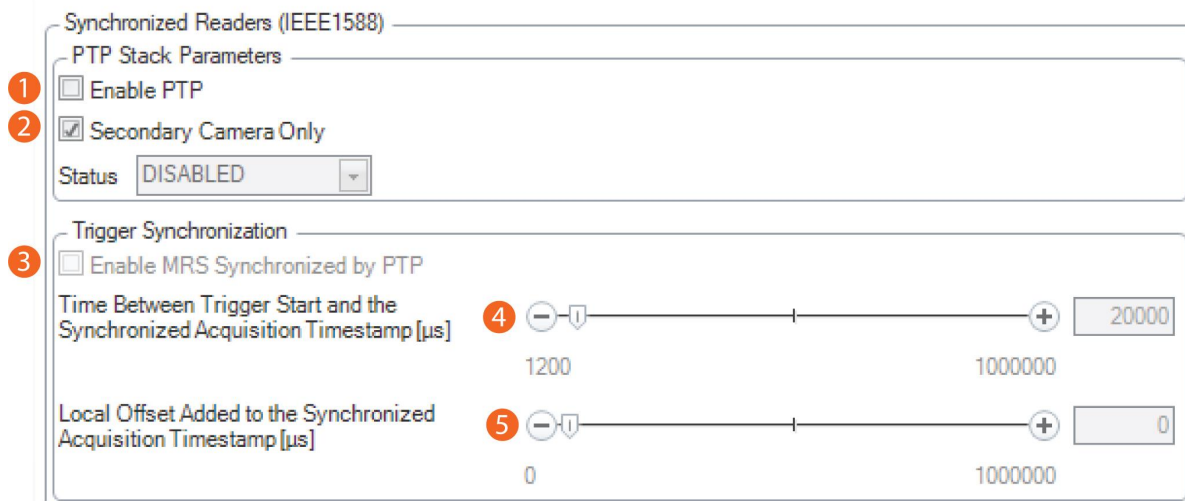

Synchronized Acquisition for the DataMan 503

Enable **Synchronized Exposure** on the DataMan Setup Tool's **Multi-Reader Sync** pane. Set the **Acquisition Delay** (μs) (relative to the received signal through the synchronization interface) on each reader individually to optionally define an exposure sequence in case the illumination of some readers might affect other readers.

You also have to set which two readers on the ends of the synchronization interface bus are bus terminators by checking the End of Sync Cable checkbox for the currently connected devices at the end of a sync cable.

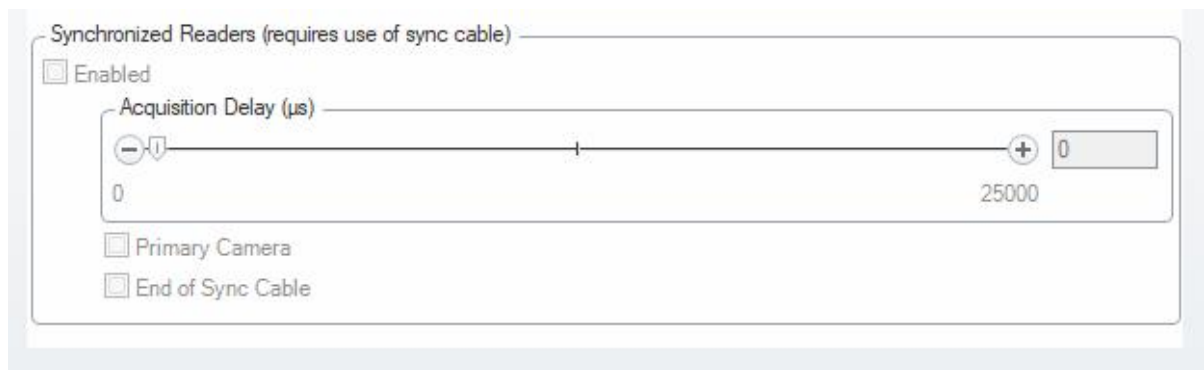

Connecting the DataMan 503 Through the Synchronized Acquisition Cable

Plug the synchronized acquisition cable into the dedicated connector on the DataMan 503.



Female connector
for synchronized
acquisition

If you are connecting more than two DataMan 503 devices, you need a Y connector with female ends to be able to use the synchronized acquisition cables.

Using C/CS-Mount Lenses

Aperture Setting

Because of the extreme sensitivity of the DataMan image sensor, for most applications, a small aperture (F8 or less) provides sufficient light for full-rate image processing while also maximizing depth of field.

Selecting Optimum Focus

You can enter live video, but for best focus optimization, place the reader in automatic trigger mode and adjust the focus until the peak read rate is obtained.

Optimizing Performance

Read Interval and Timeout Configuration

Careful configuration of the read interval (Self and Continuous triggering) or timeout value (Burst mode) can improve read rates and throughput.

- If your application uses clearly printed symbols, you can improve performance by reducing the interval or timeout value. This is because DataMan acquires images at such a high rate that a shorter timeout or interval allows the reader multiple chances to decode the symbol.
- If your application experiences poorly printed or degraded symbols, increasing the interval or timeout value can improve performance by allowing the DataMan to spend more time decoding difficult images.

In all cases, make sure that you specify an interval that allows the reader to capture at least one image of the symbol.

Optimizing Burst Trigger Parameters

Since a Burst trigger is ideal for moving applications, it is necessary to determine the correct burst size and interval in order to capture the desired length of the part as it moves under the camera. Once the interval time is determined, you can adjust the size of the burst depending on the length of the part. The variables necessary for this calculation are:

1. Line speed in mm per second
2. Code size w/quiet zone in mm
3. FOV = Field of View (x or y) in mm

You can then use the following equation to determine the interval time:

$$\text{Interval Time} = 1000 * ((\text{FOV} - 2(\text{Code Size})) / \text{Line Speed})$$

Once the interval time is determined, the size of the burst can be adjusted depending on the length of the code to capture. The max object length in mm is:

$$\text{Burst Size} * (\text{FOV} - (2 * \text{Code Size}))$$

The (2 * Code Size) variable allows for overlap of the frames taken. This takes into consideration the condition where the code is slightly out of the field of view in one frame (acquisition). The (2 * Code Size) will overlap the field of view between successive frames and allow the code to be viewed in the field of view of the next frame.

Reducing DataMan Processing Requirements

The more information that you can provide to DataMan about your application, the less work – and processing time – will be required to decode symbols.

- Only enable the symbologies that your application uses. Disabling unused symbologies reduces processing time.
- Train codes.
- Only enable extended mode decoding if your application requires it.

Avoiding Reflections and Glare

If the DataMan is mounted perpendicular to the surface containing the code to be read, reflections from the built-in illumination system can cause reflections and glare that may reduce decoding performance.

You can avoid this problem by mounting the reader at a 15° angle from vertical.

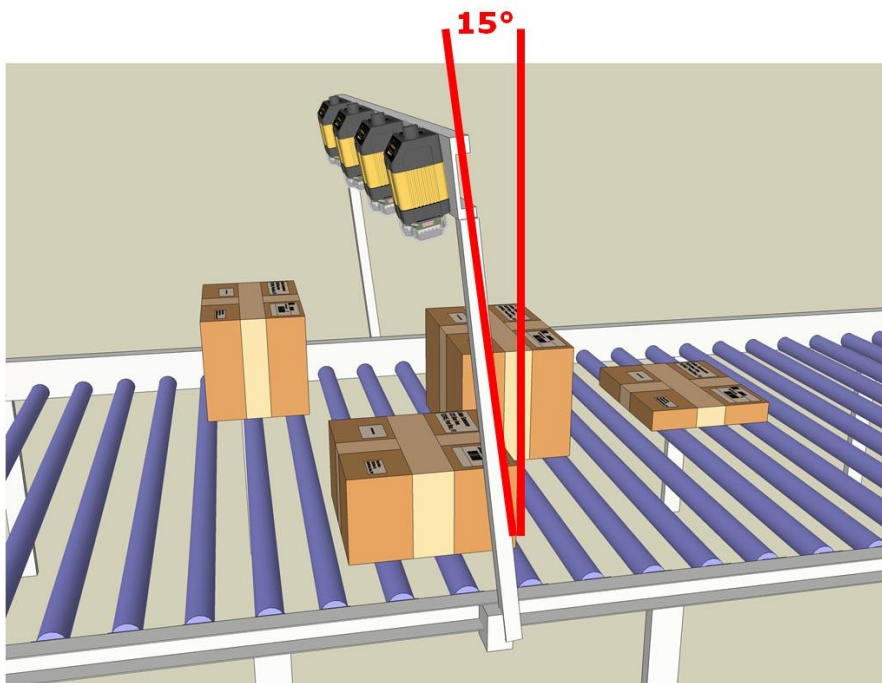

Application Guide

This section provides specific recommendations tailored to specific types of applications. Except for the sections about Multi-Reader Configurations and Variable Size Box Conveyor, all sections apply to all the DataMan fixed-mount readers.

Understanding Your Application Envelope

A wide variety of factors affects the performance and capabilities of the DataMan in a given application. You can think of this collection of factors as your application's envelope:

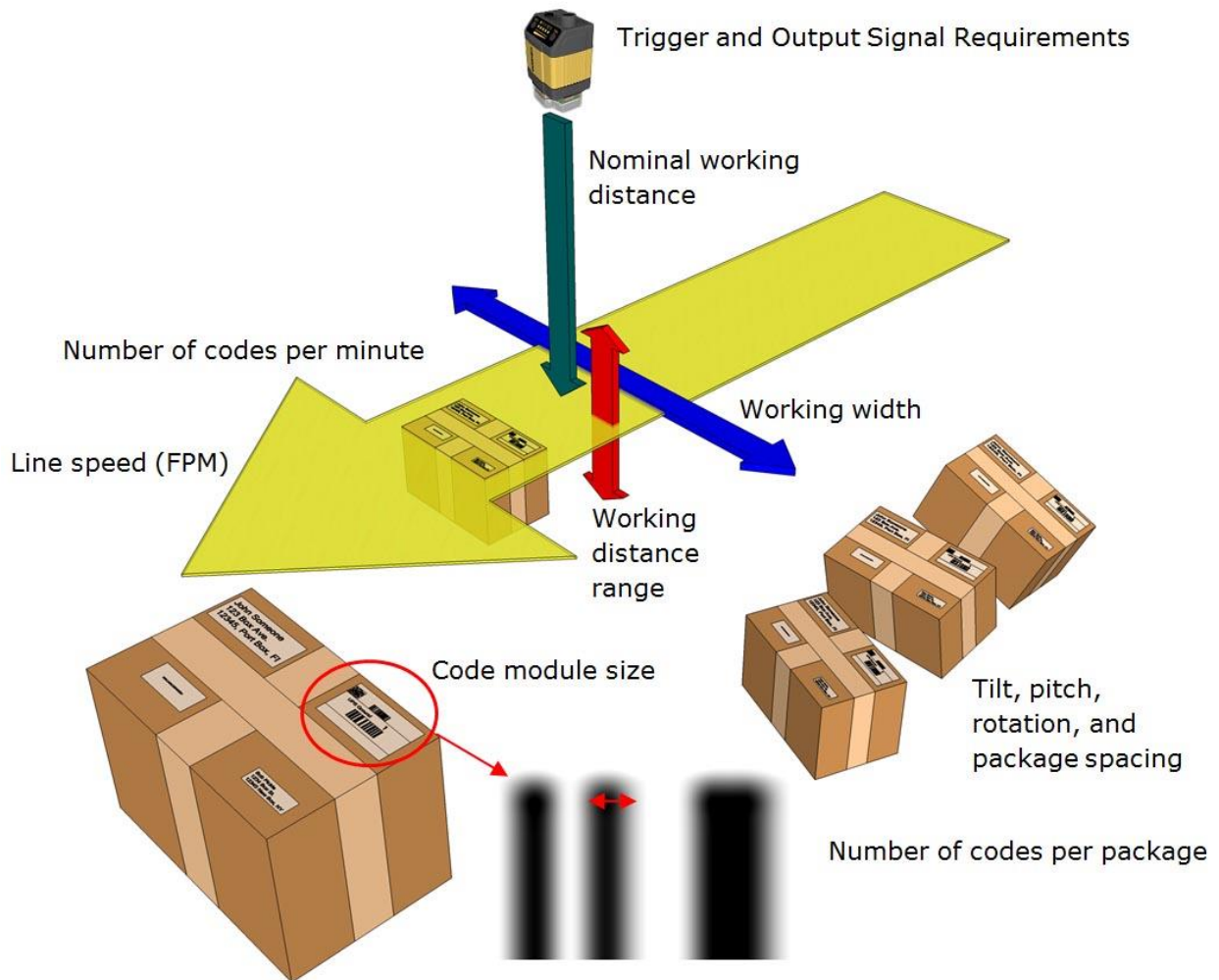

The following table describes the different parameters that define a DataMan application envelope.

Parameter	Description
Linespeed	The linear speed of the part surface containing the code to decode.
Nominal working distance	How far the code is from the front of the DataMan.
Working distance range	The range of distances, with respect to the nominal working distance, at which codes may be present.
Working width	The width of the area in which codes may appear.

Parameter	Description
Tilt, pitch, rotation, and package spacing	<p>The degree to which a code may be rotated, tilted, or pitched with respect to a plane perpendicular to the DataMan optical axis.</p> <p>Package spacing means a distance in time. If you use a conveyor that moves very fast, you need more space between the boxes. If it moves very slow, you need less space. In general, the minimum time distance between boxes must be greater than the distance between trigger on and trigger off.</p> <p>Tilt and pitch should be limited to 15-20 degrees in most cases, while rotation may be absent or may occur up to 360 degrees (omnidirectional reading).</p> <p>As described in the section Reducing DataMan Processing Requirements, the more information that you can provide to DataMan about your application, the less work – and processing time – will be required to decode symbols.</p> <ul style="list-style-type: none"> • Only enable the symbologies that your application uses. Disabling unused symbologies reduces processing time. • Train codes. • Only enable extended mode decoding if your application requires it. <p>Avoiding Reflections and Glare, you should mount the reader so that the surface containing the code to be read is not perpendicular to the reader. If your application includes tilt or pitch, make sure that the reader is mounted so that even at maximum tilt or pitch, the reader still is angled with respect to the surface being read.</p>
Code module size	The size of a code element (typically the smallest bar) in Mils.
Codes per minute	The maximum number of codes that pass in front of the reader location per minute.
Codes per image	The number of codes visible at the same time.
Trigger and output signal requirements	Whether an external trigger signal is available or a discrete output signal is required.

The following sections describe typical application envelopes for typical DataMan code reading applications, along with suggested configuration values.

Tote Scanning

Tote scanning applications typically involve reading a single barcode that is relatively well-fixtured.

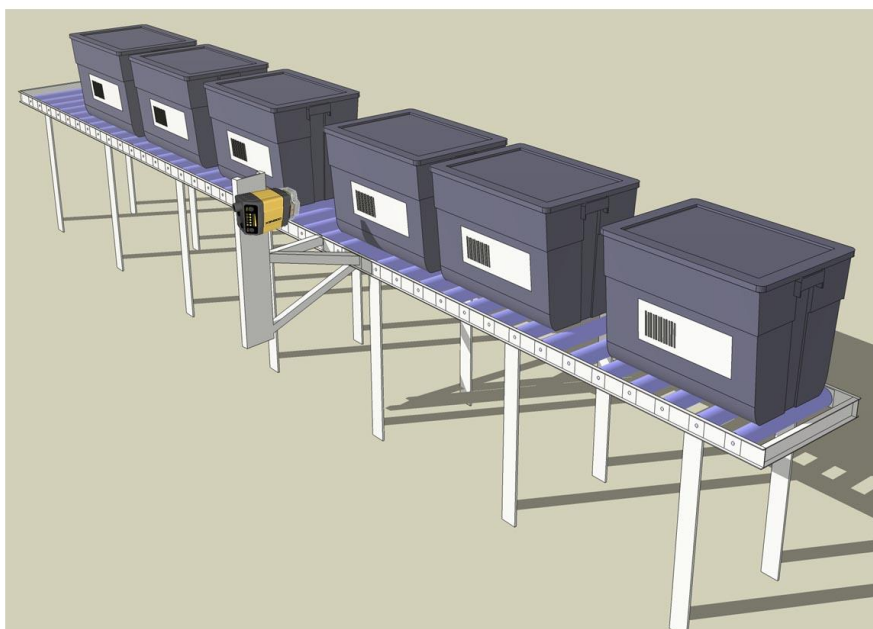

The following table lists typical values for this application:

Parameter	Typical Values
Line speed	50 FPM
Nominal working distance	6-12"
Working distance range	+/- 5"
Working width	6"
Tilt, pitch, and rotation	+/- 2°
Code module size	20 Mil
Codes per minute	20-30
Trigger and output signals	Optional

Side Scanning

Side scanning applications typically involve reading a single barcode at a consistent distance but a variable offset.

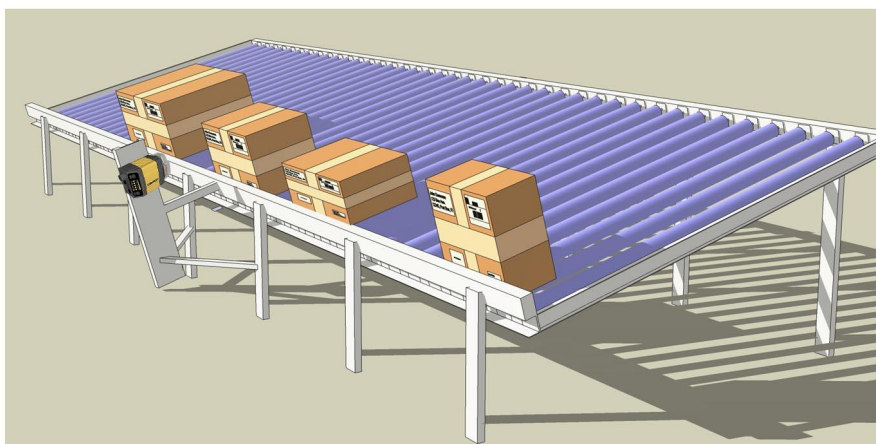

The following table lists typical values for this application:

Parameter	Typical Values
Line speed	200-300 FPM
Nominal working distance	6-12"
Working distance range	+/- 1"
Working width	12-24"
Tilt, pitch, and rotation	+/- 2°
Code module size	20 Mil
Codes per minute	100-200
Trigger and output signals	Optional

Side Scanning (Large Field)

Side scanning applications typically involve reading a single barcode at a consistent distance but a variable offset.

The following table lists typical values for this application:

Parameter	Typical Values
Line speed	200-300 FPM
Nominal working distance	6-12"
Working distance range	+/- 1"
Working width	12-24"
Tilt, pitch, and rotation	+/- 2°
Code module size	20 Mil
Codes per minute	100-200
Trigger and output signals	Optional

Print Verification (Carton Coding and Print & Apply)

This configuration reads and verifies codes from packages immediately after they are applied. The codes may be printed directly on the object (carton coding) or on a label (print & apply).

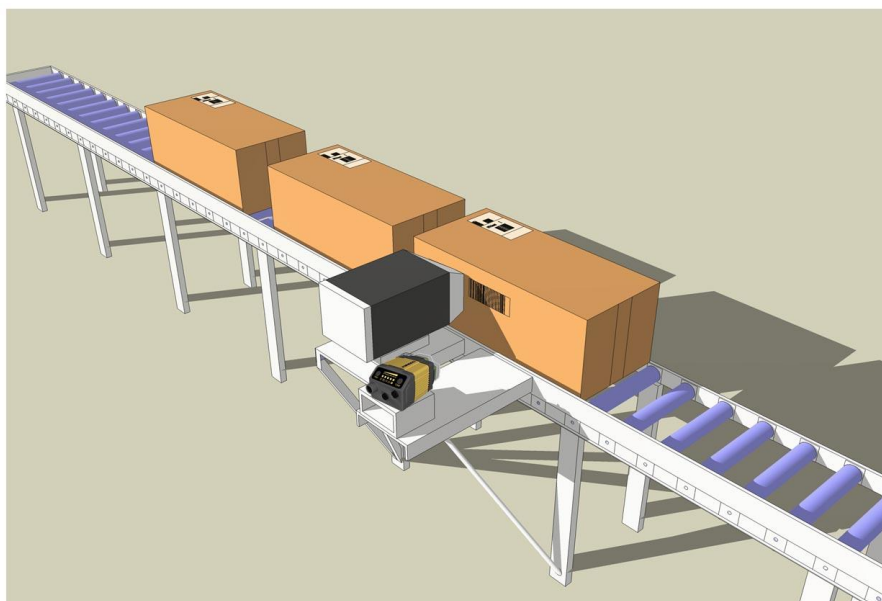

The following table lists the typical values for this application:

Parameter	Typical Values
Line speed	200-300 FPM
Nominal working distance	5-10"
Working distance range	+/- 0.5"
Working width	2-4"
Tilt, pitch, and rotation	+/- 2° (pitch, tilt, and rotation)
Code module size	20 Mil
Codes per minute	up to 200
Trigger and output signals	Likely

Manual Presentation Scanning

This configuration reads codes from objects presented manually.

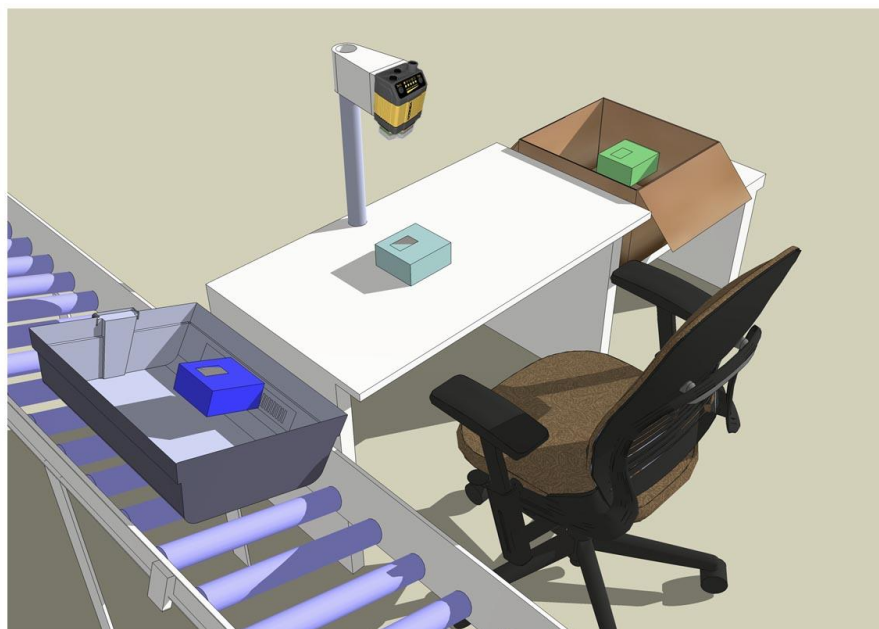

The following table lists the typical values for this application:

Parameter	Typical Values
Line speed	N/A
Nominal working distance	10-20"
Working distance range	+/- 10-
Working width	10-20
Tilt, pitch, and rotation	+/- 20° (pitch and tilt) 360° (rotation)
Code module size	20 Mil
Codes per minute	10-20
Trigger and output signals	Possible

Precautions

To reduce the risk of injury or equipment damage, observe the following precautions when you install the Cognex product:

- Route cables and wires away from high-current wiring or high-voltage power sources to reduce the risk of damage or malfunction from the following causes: over-voltage, line noise, electrostatic discharge (ESD), power surges, or other irregularities in the power supply.
- Changes or modifications not expressly approved by the party responsible for regulatory compliance could void the user's authority to operate the equipment.
- Ensure that the cable bend radius begins at least six inches from the connector. Cable shielding can be degraded or cables can be damaged or wear out faster if a service loop or bend radius is tighter than 10X the cable diameter.
- This device is certified for office use only and if used at home, there can be frequency interference problems.
- This device should be used in accordance with the instructions in this manual.
- All specifications are for reference purposes only and can change without notice.

