

Cognex MVS-8000 Series

MVS-8600 Hardware Manual

September 2012

The software described in this document is furnished under license, and may be used or copied only in accordance with the terms of such license and with the inclusion of the copyright notice shown on this page. Neither the software, this document, nor any copies thereof may be provided to or otherwise made available to anyone other than the licensee. Title to and ownership of this software remains with Cognex Corporation or its licensor.

Cognex Corporation assumes no responsibility for the use or reliability of its software on equipment that is not supplied by Cognex Corporation. Cognex Corporation makes no warranties, either express or implied, regarding the described software, its merchantability or its fitness for any particular purpose.

The information in this document is subject to change without notice and should not be construed as a commitment by Cognex Corporation. Cognex Corporation is not responsible for any errors that may be present in either this document or the associated software.

Copyright © 2013 Cognex Corporation
All Rights Reserved
Printed in U.S.A.

This document may not be copied in whole or in part, nor transferred to any other media or language, without the written permission of Cognex Corporation.

Portions of the hardware and software provided by Cognex may be covered by one or more of the U.S. and foreign patents listed below as well as pending U.S. and foreign patents. Such pending U.S. and foreign patents issued after the date of this document are listed on Cognex web site at <http://www.cognex.com/patents>.

CVL

5495537, 5548326, 5583954, 5602937, 5640200, 5717785, 5751853, 5768443, 5825483, 5825913, 5850466, 5859923, 5872870, 5901241, 5943441, 5949905, 5978080, 5987172, 5995648, 6002793, 6005978, 6064388, 6067379, 6075881, 6137893, 6141033, 6157732, 6167150, 6215915, 6240208, 6240218, 6324299, 6381366, 6381375, 6408109, 6411734, 6421458, 6457032, 6459820, 6490375, 6516092, 6563324, 6658145, 6687402, 6690842, 6718074, 6748110, 6751361, 6771808, 6798925, 6804416, 6836567, 6850646, 6856698, 6920241, 6959112, 6975764, 6985625, 6993177, 6993192, 7006712, 7016539, 7043081, 7058225, 7065262, 7088862, 7164796, 7190834, 7242801, 7251366, EP0713593, JP3522280, JP3927239

VGR

5495537, 5602937, 5640200, 5768443, 5825483, 5850466, 5859923, 5949905, 5978080, 5995648, 6002793, 6005978, 6075881, 6137893, 6141033, 6157732, 6167150, 6215915, 6324299, 6381375, 6408109, 6411734, 6421458, 6457032, 6459820, 6490375, 6516092, 6563324, 6658145, 6690842, 6748110, 6751361, 6771808, 6804416, 6836567, 6850646, 6856698, 6959112, 6975764, 6985625, 6993192, 7006712, 7016539, 7043081, 7058225, 7065262, 7088862, 7164796, 7190834, 7242801, 7251366

OMNIVIEW

6215915, 6381375, 6408109, 6421458, 6457032, 6459820, 6594623, 6804416, 6959112, 7383536

The following are registered trademarks of Cognex Corporation:

acuCoder	acuFinder	acuReader	acuWin	BGAll	Checkpoint
Cognex	Cognex, Vision for Industry	CVC-1000	CVL	DisplayInspect	
ID Expert	PastelInspect	PatFind	PatFlex	PatInspect	PatMax
PatQuick	PixelProbe	SMD4	Virtual Checksum	VisionLinx	VisionPro
VisionX					

Other Cognex products, tools, or other trade names may be considered common law trademarks of Cognex Corporation. These trademarks may be marked with a "TM". Other product and company names mentioned herein may be the trademarks of their respective owners.

Contents

Preface	7
Style Conventions Used in This Manual	8
Text Style Conventions	8
Cognex Offices	9
Chapter 1: MVS-8600 Installation	11
Host PC Requirements	12
Installing the MVS-8600	13
Selecting an MVS-8601 or MVS-8602 PCI Slot	13
PCI Bus Speed	14
The PCI-X Bus	15
Understanding Bus Bandwidth	16
Selecting an MVS-8602e PCIe Slot	16
Installation Steps	17
Configuring Cameras	19
Initial Setup for Camera Link Cameras	19
Before you Begin	20
Using the Cognex Camera Link Serial Communications Utility	20
Load the Configuration File for Your Camera	21
Connect to the Camera and Send the Configuration File	22
Ongoing Setup for Camera Link Cameras	22
Custom Camera Link Setup Information	23
Connecting Cameras	24
MVS-8602 and MVS-8602e Base Configuration Camera Connections	25
MVS-8602e Medium Configuration Camera Connections	25
Supplying Camera Power	26
Power over Camera Link (PoCL)	26
Connecting Parallel I/O Devices	29
Triggers, Strobes, and Encoders	29
Programmable I/O Lines	29
Loadable Software I/O Configurations	31
Specifying the I/O Software Option	32
Connecting Triggers	32
Triggers for I/O Options 1 and 2	32
Triggers for I/O Option 3	34
Connecting Strobes	35
Strobes for I/O Options 1 and 2	35
Connecting Encoders for Line Scan Cameras	36
Connecting Programmable I/O Devices	36
Programmable Input Lines	37
Programmable Output Lines	38

■ Contents

I/O Connection Reference Tables	40
Chapter 2: MVS-8600 Hardware	43
MVS-8600 Components	44
MVS-8600 Series Overview	44
PCI Bus Interface	45
PCI Express Bus Interface	45
Video Acquisition Interface	46
Specifications	46
Support for I/O Devices	49
Mechanical Specifications	50
Component Diagrams	50
Connector Summary	51
Jumper Summary	52
Environmental Requirements	52
Shipping	53
Standards Compliance	54
International	54
European Community	54
Electrical Specifications	55
Power Requirements	55
Power Output Selection Jumpers S1 and S2	55
MVS-8601 and MVS-8602 Power Selection Jumpers	56
MVS-8602e Power Selection Jumpers	56
Jumpers S3-S10	57
Resettable Fuses	57
DIP Switches	58
Camera Connector	58
Camera Cables	60
Parallel I/O Connectors and Cables	60
MVS-8600 Signal Names	61
Hirose HR10 Connector P3	62
26-Pin IDC Connector P4	63
26-Pin IDC Connector P6	65
Line Numbering	67
I/O Connection Module for the MVS-8600	68
Layout of I/O Connection Module	68
Specifications for the I/O Connection Module	69
Cables from MVS-8600 to I/O Module	70
Wiring Devices to the I/O Connection Module	71
Circuit Logic Diagrams	73
Programmable Line Input Circuitry	73

Programmable Line Output Circuitry	74
I/O Connection Module Input Circuitry	76
I/O Connection Module Output Circuitry	77
I/O Connection Module Adds Conversion Delay	77
Chapter 3: Using Encoders with Line Scan Cameras	79
Encoders and the MVS-8600 Series	79
Encoder Characteristics	80
Encoder Electrical Interface	80
Connecting Encoders	83
Relationship Between Encoder and Camera Channels	84
Encoder Support Varies With I/O Configuration Loaded	84
Index	85

■ Contents

Preface

This manual describes the Cognex MVS-8600 series frame grabbers in the following chapters:

Chapter 1, *MVS-8600 Installation*, describes how you configure and install an MVS-8600 series frame grabbers.

Chapter 2, *MVS-8600 Hardware*, describes the MVS-8600 hardware, including environmental and power requirements, and its mechanical and electrical specifications.

Chapter 3, *Using Encoders with Line Scan Cameras*, describes the use of encoders with line scan cameras, and specifies the types of encoders supported.

Appendix A, *Hirose HR10 Connector Pinouts* provides pin numbering diagrams.

Style Conventions Used in This Manual

This manual uses the style conventions described in this section for text and software diagrams.

Text Style Conventions

This manual uses the following style conventions for text:

boldface	Used for C/C++ keywords, function names, class names, structures, enumerations, types, and macros. Also used for user interface elements such as button names, dialog box names, and menu choices.
<i>italic</i>	Used for names of variables, data members, arguments, enumerations, constants, program names, file names. Used for names of books, chapters, and sections. Occasionally used for emphasis.
<code>courier</code>	Used for C/C++ code examples and for examples of program output.
bold courier	Used in illustrations of command sessions to show the commands that you would type.
< <i>italic</i> >	When enclosed in angle brackets, used to indicate keyboard keys such as <Tab> or <Enter>.

Cognex Offices

The following are the address and phone number of Cognex Corporate Headquarters, and the address of the Cognex web site:

Corporate Headquarters

Cognex Corporation
Corporate Headquarters
One Vision Drive
Natick, MA 01760-2059
(508) 650-3000

Web Site

<http://www.cognex.com>

■ **Preface**

NOTES

This chapter describes how to install an MVS-8600 series frame grabber into your PC, how you connect cameras, and how you connect peripheral equipment such as triggers, strobes, or other I/O devices.

Notes on Terminology

Throughout this manual:

- The term MVS-8600 or MVS-8600 series refers to all of the frame grabbers described in this document.
- The terms MVS-8601 and MVS-8602 are used when discussing features specific to frame grabbers that plug into the PCI bus.
- PCI refers to 32-bit PCI card slots, while PCI-X refers to 64-bit (extended) PCI card slots.
- The term MVS-8602e is used to describe the board that plugs into the PCI Express bus.
- PCIe is sometimes used to refer to the PCI Express bus.
- Frame grabber names are sometimes abbreviated, dropping the MVS- prefix. For example, 8600, 8602 and 8602e.

Host PC Requirements

To install an MVS-8600 frame grabber, the host PC should meet the following minimum requirements:

- For MVS-8601 and MVS-8602 frame grabbers the motherboard's chip set must be fully compliant with the PCI 2.1, 2.2, or 2.3 specifications. Motherboards with Intel chip sets that support Intel Pentium, Pentium III, Pentium 4, and Xeon CPUs are known to be compliant. Motherboards with VIA chip sets that support the AMD K6-III, and Athlon CPUs are known to be compliant.
 - One available PCI or PCI-X card slot.
- For the MVS-8602e frame grabber the motherboard's chip set must be fully compliant with the PCI Express Revision 1.0a specifications. Motherboards with Intel chip sets that support Intel Pentium 4, Pentium D, Core Duo, Core 2 Duo and Xeon CPUs are known to be compliant.
 - One available PCI Express card slot that will support an x4 board.
- One available CD-ROM drive (or access to one over a network) to install the Cognex software.

Additional requirements may be imposed by your Cognex software package. Check the Cognex software's release notes or *Getting Started* manual for the software's requirements, if any, on:

- Minimum recommended CPU speed
- Host operating system, including the supported service pack release level
- Supported video cards
- Desktop color depth (the number of colors displayable)
- Desktop size (the number of pixels displayable in width and height on your screen)
- The presence of a mouse or other pointing device

Installing the MVS-8600

This section describes the steps to prepare for installation and to install an MVS-8600 frame grabber. The following section describes how to select and install an MVS-8601 or MVS-8602 frame grabber in a PC with a PCI or PCI-X bus. See *Selecting an MVS-8602e PCIe Slot* on page 16 for a description of installing an MVS-8602e in a PC with a PCI Express bus.

Selecting an MVS-8601 or MVS-8602 PCI Slot

PCI card slots come in two sizes; 32-bit, and 64-bit. The 64-bit card slots are longer to accommodate the extra pins for the wider bus data path. MVS-8601 and MVS-8602 boards are *universal* PCI boards in that they can be plugged into either a 32-bit slot or a 64-bit slot. When plugged into a 32-bit slot they automatically operate in 32-bit mode and when plugged into a 64-bit slot they operate in 64-bit mode.

The PCI bus can be designed for +3.3 V operation or +5 V operation. The +3.3 V and +5 V card slots have different keys so you cannot plug a PCI card into a slot with the wrong voltage. Here again the *universal* design allows the boards to operate at either +3.3 V or +5 V and are keyed such that they can be plugged into either type slot. See Figure 1 below.

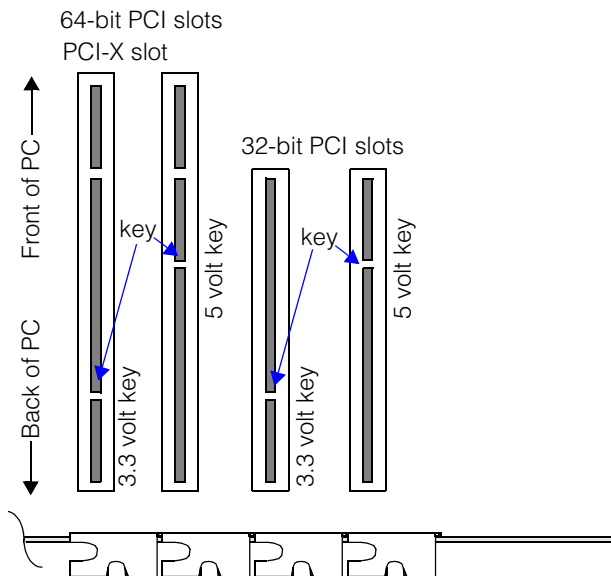

Figure 1. 32-bit and 64-bit PCI card slots

MVS-8601 and MVS-8602 boards are designed with a 64-bit data path so when you plug an MVS-8601 or MVS-8602 into a 32-bit PCI slot some of the pins are not used. The unused pins hang out over the end of the connector. See Figure 2.

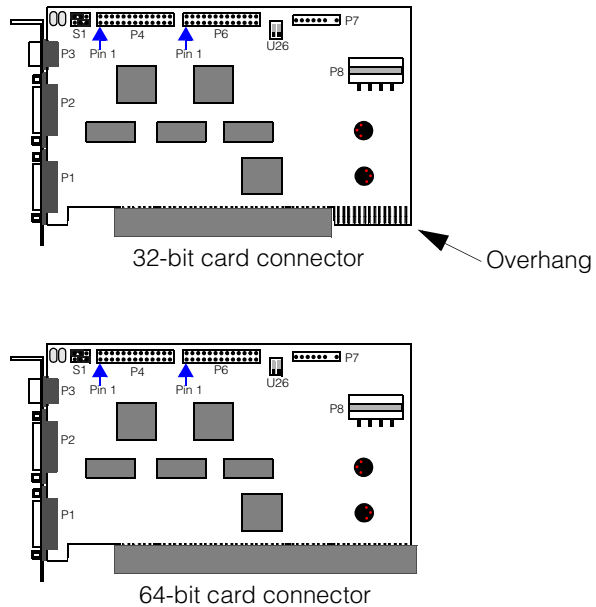

Figure 2. MVS-8601 and MVS-8602 card slots

PCI Bus Speed

The PCI bus clock speed can be 33 MHz or 66 MHz depending on the PC motherboard you are using. You cannot tell the bus speed by looking at the card slots. You must read the motherboard specifications to find this information. MVS-8601 and MVS-8602 frame grabbers will run at either 33 MHz or 66 MHz. You do not need to make any changes to the frame grabber board. It adapts automatically to the PCI bus clock speed and runs faster at 66 MHz than at 33 MHz.

Note For best performance, place the MVS-8601 or MVS-8602 in a 64-bit/66 MHz slot.

The PCI-X Bus

The PCI-X bus was introduced to address some of the PCI bus limitations and to support the higher performance requirements of newer computers. All PCI-X card slots are 64-bits wide although the bus will accommodate 32-bit operation for boards using that design. The PCI-X bus clock runs at 66 MHz and higher and will not support boards designed to run at 33 MHz.

Table 1 below summarizes the support for the PCI bus and PCI-X bus.

	Data Path	Clock Speed	Bus Bandwidth (MBytes/sec) [Theoretical]	Bus Bandwidth (MBytes/sec) [Sustainable]
PCI	32-bits	33 MHz	133	80
		66 MHz	266	160
	64-bits	33 MHz	266	160
		66 MHz	533	300
PCI-X¹	32-bit	66 MHz	533	300
	64-bit	66 MHz	533	300

Note 1: The MVS-8601 and MVS-8602 have a maximum speed of 66 MHz. When used in PCI-X slots with higher speeds, the boards operate at 66 MHz.

Table 1. PCI and PCI-X summary

Notes

The PCI and PCI-X buses are shared buses and requires all cards on a given bus segment to run at the same clock speed. So, if another board plugged into your PCI bus segment runs at only 33 MHz, all other boards plugged into the same segment are limited to 33 MHz.

Also note that most PC motherboards support more than one PCI bus segment and you cannot tell which card slots are on the same segment by looking at the motherboard. You can only get this information from the motherboard specifications.

Understanding Bus Bandwidth

When evaluating whether a particular slot configuration will meet your application's bandwidth requirements, you should keep the following in mind:

- The **Sustainable** bus bandwidth reflects the total amount of data that can be transmitted per second for a running system.
- Each camera's bandwidth **consumption** can be computed by multiplying its image size by the number of bytes per pixel by the number of frames per second. For example, a 1600 x 1200 monochrome camera (8 bits per pixel) running at 30 frames per second would consume 57.6 MBytes/sec. A 1024 x 768 color camera (3 8-bit bytes per pixel) running at 20 frames per second would consume 47.1 MBytes/sec.

Selecting an MVS-8602e PCIe Slot

The MVS-8602e has an x4 PCI Express bus interface. PCI Express card slots come in four sizes: x1, x4, x8 and x16 as shown in Figure 3 below.

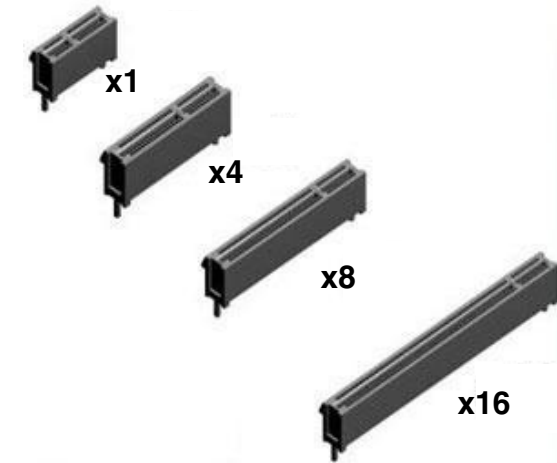

Figure 3. PCI Express card slots

The MVS-8602e has an x4 bus interface and cannot physically fit into an x1 card slot, but will physically fit into any of the other three card slots. The MVS-8602e will operate when plugged into x8 or x16 slots, but depending on your PC's motherboard, the card may only operate at x1 speed (one fourth of x4 speed).

Note Some PC motherboards support x4 speed for x4 cards connected to x8 or x16 slots, but other motherboards drop to x1 speed. Cognex recommends that you place the MVS-8602e in an x4 slot. If you need to use an x8 or x16 slot, consult the BIOS manufacturer's documentation to determine whether the BIOS supports x4 or x1 operation under these conditions.

Installation Steps

To install an MVS-8600 frame grabber, follow these steps:

Caution *Electrostatic discharge (ESD) can damage the electronic components of your Cognex hardware.*

1. Wear a grounded, static-dissipating wrist strap for ESD protection.
2. Power off the PC and remove its cover.
3. Select a slot for the frame grabber using the information in the previous sections as a guide. Remove the slot cover and store it for future use.
4. Press the board into its slot until it is seated firmly.
5. Locate the external +12 V power connector at board position P8, as illustrated in Figure 4. Locate an unused disk drive power connector from the host PC's power supply, and connect it directly to the P8 jack. The connectors are keyed, and can only be inserted one way.

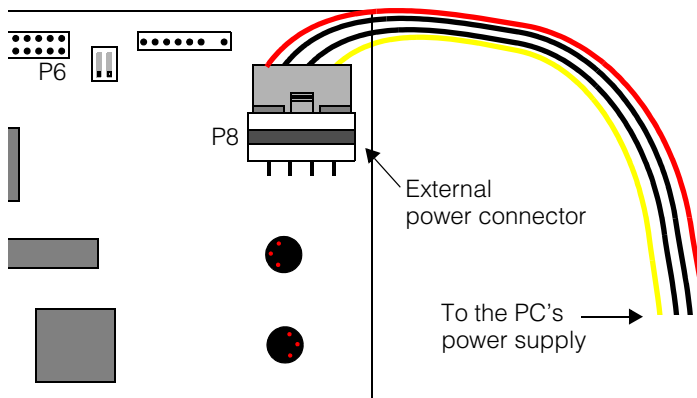

Figure 4. Connect power supply cable

If your host PC does not have an available power connector, use the supplied Y-splitter cable to split one of the existing power connectors into two.

If your PC has SATA power connectors rather than PATA (4-pin) power connectors, you can use the SATA adapter supplied with your MVS-8600, as shown in Figure 5.

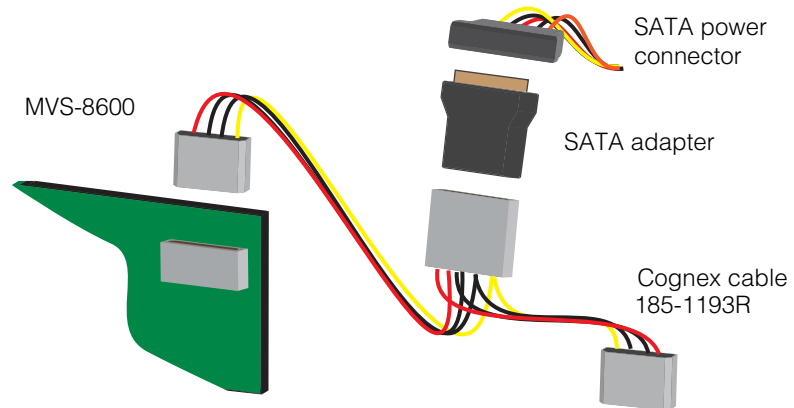

Figure 5. SATA adapter and power adapter cable

6. If your PC uses faceplate screws, replace the faceplate screw to anchor the frame grabber so that it does not loosen when attaching and removing cameras.
7. Replace your PC's cover.

Caution

Do not power on the PC until you have connected cameras and any parallel I/O devices to the frame grabber.

Configuring Cameras

This section describes the setup steps for the cameras supported for use with MVS-8600 frame grabbers.

The Camera Link specification provides for a virtual serial port interface that is accessed using RS-232 serial communication protocols over the LVDS Camera Link bus. Some camera manufacturers provide a utility to set up and configure their Camera Link cameras, but not all do.

Note There is no standard language or protocol for configuring Camera Link cameras. Each manufacturer has a different camera configuration syntax at the serial communication command line.

All Cognex software releases that support MVS-8600 frame grabbers are shipped with the Cognex Camera Link Communications Utility that you can use to configure any Camera Link camera. You can use either a camera manufacturer's tool or the Cognex utility to configure your Camera Link camera. If you use a camera manufacturer's tool, that tool may communicate with the camera using the communications DLL supplied with your Cognex software.

(See *Using the Cognex Camera Link Serial Communications Utility* on page 20).

The Cognex Camera Link Serial Communications Utility lets you

- Connect to any installed Camera Link camera.
- Send commands to and receive responses from a connected Camera Link camera.
- Load and save sets of commands

Note Cognex *strongly* recommends that you stop image acquisition when configuring a Camera Link camera using the utility. Also, the Camera Link utility is not designed to be multi-process safe. Stop all programs that might be communicating with or acquiring images from the camera before using the utility.

Initial Setup for Camera Link Cameras

Note If you purchase a supported Camera Link camera from Cognex, the camera is delivered ready to use with the MVS-8600. If you acquire your cameras elsewhere, you must configure them yourself as described in this section.

This section provides the steps to set up a Camera Link camera using the Cognex Camera Link Serial Communication Utility.

Before you Begin

Before attempting to configure your Camera Link camera, you must perform the following steps:

1. Install an MVS-8600 frame grabber in your PC
2. Install a Cognex software product that supports your MVS-8600. Make sure that you install the Cognex drivers supplied with your software product.
3. Restart your PC.
4. Connect a supported Camera Link camera to the MVS-8600.
5. Make sure that the camera is not actively acquiring images by disabling triggers for the camera.

Using the Cognex Camera Link Serial Communications Utility

As shown in the following table, the Cognex Camera Link Serial Communications Utility (*cogclserial.exe*) is installed in different locations depending on which Cognex software package that you are using.

VisionPro	
Start Menu Command	Cognex->VisionPro->Utilities->CameraLink->CogCLSerial
Default Installation Directory	<i>\Program Files\Cognex\VisionPro\cogclser</i>
CVL	
Start Menu Command	Cognex->CVL->Utilities->CameraLink->CogCLSerial
Default Installation Directory	<i>\Program Files\Cognex\CVL\cogclser</i>

Table 2. Serial Communications Utility Installation

Figure 6 provides an overview of using the utility.

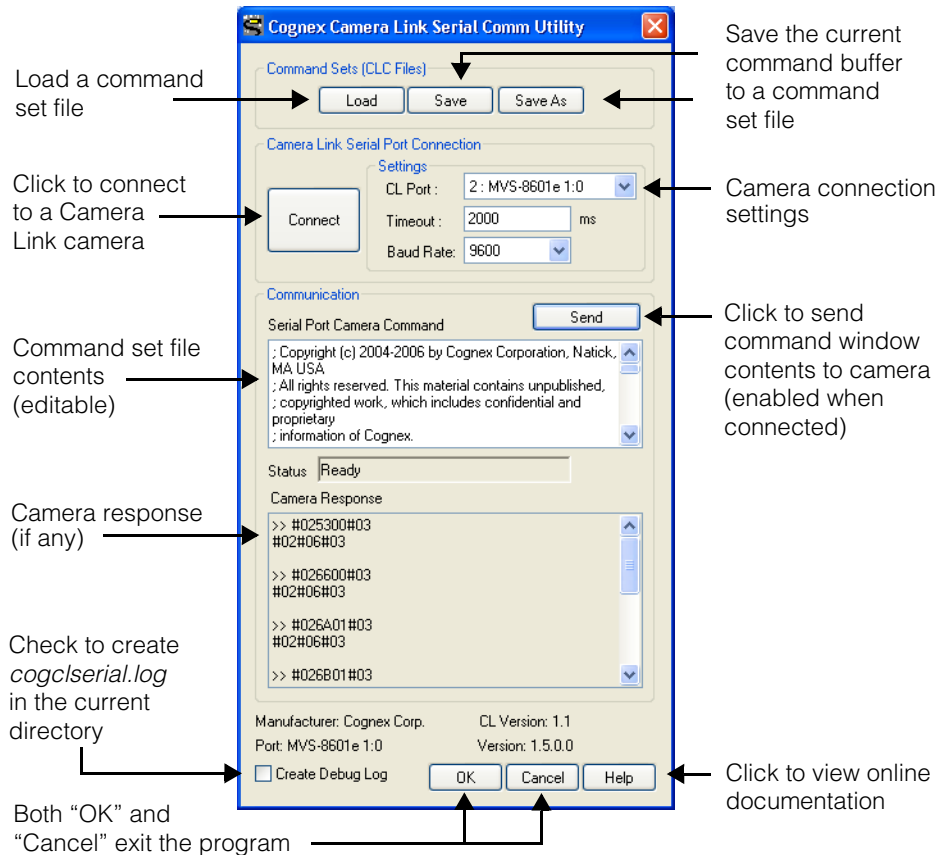

Figure 6. Cognex Camera Link Serial Communication Utility

Load the Configuration File for Your Camera

Cognex supplies one or more Camera Link configuration files (.clc files) for each supported camera (there is typically one CLC file for each supported video format). The CLC files are installed in the same directory as the Cognex Camera Link Serial Communications Utility, *Program Files\Cognex\VisionPro\cogclser* for VisionPro and *Program Files\Cognex\CVL\cogclser* for CVL.

Each CLC file is named after the camera video format that it supports. The following example is for the Dalsa P2-2x-02k40 Camera Link camera.

Camera	CLC File	Notes
Dalsa P2-22-04k40	<i>dalsa_p2_2x_04k40_8bit.clc</i>	<ul style="list-style-type: none"> • Dual-tap • 8-bit output format • SMART EXSYNC exposure mode

Once you have selected the correct file for your camera, click **Load**. The file's contents will appear in the buffer window.

Note For detailed information about the format and syntax of a CLC file, see the online documentation provided with the Cognex Camera Link Configuration Utility.

Connect to the Camera and Send the Configuration File

Before you can transmit the configuration information to a Camera Link camera, you must connect to the camera by following these steps:

1. Specify a camera port number in the **Camera Link Port** field, as follows:
 - For one MVS-8601 always specify 0.
 - For one MVS-8602 or one MVS-8602e, specify 0 or 1 to designate the camera connected to physical port 0 or 1, respectively.
 - For cameras connected to a second MVS-8600, specify 2 or 3 to designate cameras connected to the second board's physical ports 0 or 1, respectively.
2. Do not change the **Timeout** and **Baud Rate** values from their default values.
3. Click the **Connect** button.

If the utility connects successfully, it enables the **Send** button. Simply click the **Send** button to transmit the configuration file to the camera and then click **OK** to exit the utility.

Ongoing Setup for Camera Link Cameras

In addition to establishing the correct initial configuration for a Camera Link camera, you can also use the Cognex Camera Link Configuration Utility to adjust your camera's settings after installation.

If you want to adjust camera settings such as gain and offset, consult the camera manufacturer's documentation for the syntax of the command to use. You can also look through the comments in your camera's CLC file for suggested commands. You can use the Cognex Camera Link Configuration Utility to change configuration parameters interactively, and you can use the utility to create, save, and load command files.

Note Be sure to store setting changes in the camera, so that it is configured correctly at each power-on.

Custom Camera Link Setup Information

This section contains information about custom configuration that may be required for specific Camera Link cameras.

Correcting Basler L402k Images

The Basler L402k line scan camera can exhibit striping in the right half of the image. You can calibrate out the striping by following the procedures given in Basler's *L400k User's Manual*. See "Shading Correction" in section 3.6 of the Basler manual.

Apply both DSNU and PRNU shading correction, as described in the Basler manual. The provided calibration method is scene and lighting dependent, and thus must be performed on site.

Once calibrated, be sure to save your correction values to the camera's non-volatile memory as described in the same section of Basler's manual.

Connecting Cameras

Cognex supports *Base configuration* and *Medium configuration* Camera Link cameras. Base configuration cameras require one cable connected to a port of an MVS-8600 frame grabber. Medium configuration cameras require two cables connected to both ports of an MVS-8602e frame grabber. The MVS-8602e is the only frame grabber that supports medium configuration cameras.

If your Camera Link camera uses a standard MDR-26 Camera Link connector, use one of the following Cognex cables to connect an MVS-8600 camera port to your camera:

- 185-0241, 5 meter Camera Link cable
- 185-0242, 10 meter Camera Link cable

If your camera is equipped with a MiniCL connector, use these Cognex cables:

- 185-1001, 5 meter Miniature Camera Link cable
- 185-1002, 10 meter Miniature Camera Link cable

In 2007, the Camera Link specification added support for the PoCL feature which allows the frame grabber to provide +12 V power to a PoCL camera through the camera cable. The change uses four camera cable lines that were previously tied to the cable shield, providing two +12 V power supply lines and two ground returns. As described in the section *Determining if Your MVS-8602e Supports PoCL* on page 27, newer MVS-8602e boards support the use of PoCL.

If you are using a PoCL camera equipped with a MiniCL connector, use this Cognex cable:

- 185-1093R, 5 meter high-flex PoCL Miniature Camera Link cable

Cognex Camera Link cables have thumbscrews on one end and a click-lock connector on the other end.

- Note**
- Connect the click-lock connector to the frame grabber.
 - Connect the thumbscrew connector to your Camera Link camera.

MVS-8602 and MVS-8602e Base Configuration Camera Connections

Follow the rules below to determine which camera port to use on the MVS-8602 and MVS-8602e (two-camera port frame grabbers) to connect base configuration Camera Link cameras.

- Connect a single *area scan* camera to either camera port. Cognex recommends using camera port 0 first, but this is for clarity when using Cognex software, not a requirement of the hardware.
- Connect a single *line scan* camera only to camera port 0.
- When using one line scan and one area scan camera, connect the line scan camera to camera port 0 and the area scan camera to camera port 1.
- When using *line scan* cameras, you must specify the appropriate software I/O configuration to specify whether you are using an LVDS encoder or TTL (open collector) encoder. For VisionPro, this means editing the *visionpro.ini* configuration file; for CVL, this means instantiating the appropriate **cclIOConfig**-derived class.
- You must use the I/O cable that matches the software I/O configuration, as shown in Table 3 on page 31.

MVS-8602e Medium Configuration Camera Connections

Medium configuration cameras have two MDR-26 connectors that you must connect to the MVS-8602e frame grabber using two of the cables listed on page 24. It is important which camera connector is connected to which MVS-8602e camera port. The camera connectors will be labeled with a low and high designator. For example, 0 and 1, or 1 and 2.

Ports on the MVS-8602e are labeled P1 (camera port 1) and P2 (camera port 0). The lower ranking connector on the camera must be connected to MVS-8602e port 0, and the higher ranking camera connector must be connected to MVS-8602e port 1. See the example in Figure 7 below.

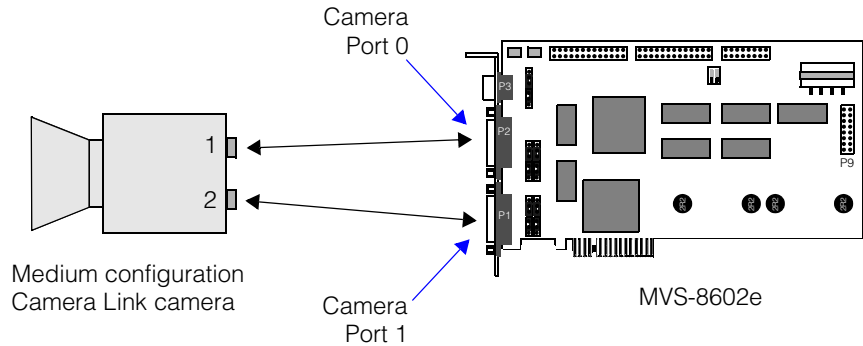

Figure 7. Medium camera connection example

Supplying Camera Power

You can provide camera power in any of the following ways:

1. From an external power supply as specified by the camera's manufacturer.
2. From the MVS-8600 by connecting to the +12 V and/or +5 V jacks of the MVS-8600 I/O connection module. (See Figure 24 on page 71). In this case:
 - If a disk drive power plug from the host PC's power supply is connected to the MVS-8600 P8 jack, up to 1.0 A can be drawn (all cameras).
 - If a disk drive power plug from the host PC's power supply is not connected to the MVS-8600 P8 jack, up to 0.5 A can be drawn (all cameras).
3. From the MVS-8602e, if the board supports it, by using a PoCL cable from the frame grabber to the camera. The two bullets above apply for this case also. See the following section for information about PoCL.

Power over Camera Link (PoCL)

In 2007, the Camera Link specification added support for the PoCL feature which allows the frame grabber to provide +12 V power to a PoCL camera through the camera cable. The change uses four camera cable lines that were previously tied to the cable shield, providing two +12 V power supply lines and two ground returns. These cables are covered in the section *Camera Connector* on page 58 and *Camera Cables* on page 60.

To use PoCL you need a PoCL camera that expects to get +12 V power from the camera cable, a PoCL camera cable and a PoCL frame grabber.

Note You must provide external +12V power to the MVS-8602e through the P8 connector as described in the section *Installation Steps* on page 17 to use PoCL. If you do not connect +12V power to the P8 connector, PoCL cameras will not work.

Determining if Your MVS-8602e Supports PoCL

PoCL support was added to the MVS-8602e frame grabber at revision 4. To identify a revision 4 MVS-8602e, use the methods described in this section.

- **Part Number:** Revision 4 MVS-8602e board carry part number **207-1000-4R**.
- **Labeling:** MVS-8602e boards that support PoCL are labeled with the PoCL logo, as shown in Figure 8.

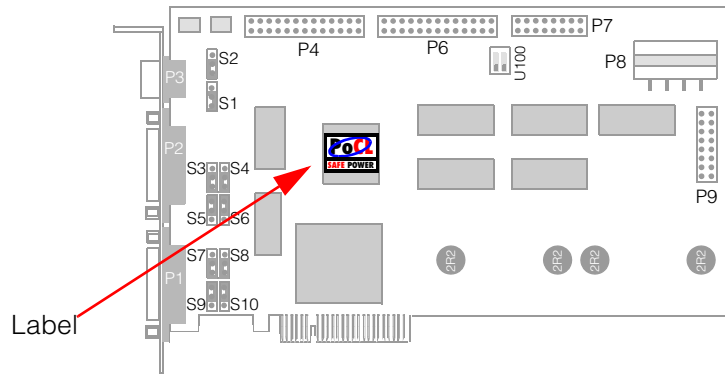

Figure 8. MVS-8602e PoCL labeling

Backward Compatibility

If your MVS-8602e supports PoCL, you can safely connect it to both PoCL and non-PoCL cameras using both PoCL and non-PoCL cabling, although you must use a PoCL cable if you wish to provide power to a PoCL camera.

You can safely connect older versions of the MVS-8602e that do not support PoCL to non-PoCL cameras using either PoCL or non-PoCL cables. You cannot operate a PoCL camera using a non-PoCL version of the MVS-8602e.

Warning

In general, you can safely use a mixed configuration of PoCL and non-PoCL cameras, as long as you shut the PC down before connecting or disconnecting the cameras. If you attempt to change from a PoCL to non-PoCL camera (or from a non-PoCL to a PoCL camera) while the PC is powered on, you may damage the MVS-8602e.

Connecting Parallel I/O Devices

The MVS-8600 supports the connection of I/O devices over parallel signal interface lines, including triggers, strobes, encoders, sensors, LEDs, switches, and programmable controllers.

Triggers, Strobes, and Encoders

Connect wires from trigger, strobe, and encoder devices to the frame grabber's I/O connection module, Cognex part number 800-5885-1. The I/O module extends selected signals from the frame grabber's Hirose HR10 connector out to screw terminals to connect device wires. Connections of this type are described in more detail in sections below.

Note The I/O connection module operates in three different modes, depending on both the loaded software I/O configuration **and** the cable that you use to connect the module to the MVS-8600. The cable part numbers and software I/O configurations are listed in Table 3 on page 31

Programmable I/O Lines

Other devices such as sensors, LEDs, switches, and controllers can be managed and controlled by the MVS-8600 under the direction of your vision processing application. Connect such devices to the programmable opto-isolated input or output lines that originate on board connectors P4 or P6. To bring the P4/P6 signals to the PC's back panel, connect the I/O extension cable (Cognex part number 300-0240) to P4, or P6, or both.

Note Unlike the Hirose HR10 connector, which exposes a subset of the I/O lines, the P4 and P6 connectors expose *all* available I/O lines on the MVS-8600.

The other end of the I/O extension cable replaces an empty slot cover on the host PC's back panel. As an alternative, you can remove the DB-25 connector from the cable's panel plate and mount it into a knock-out on the back of the PC.

Figure 9 illustrates the I/O extension cable.

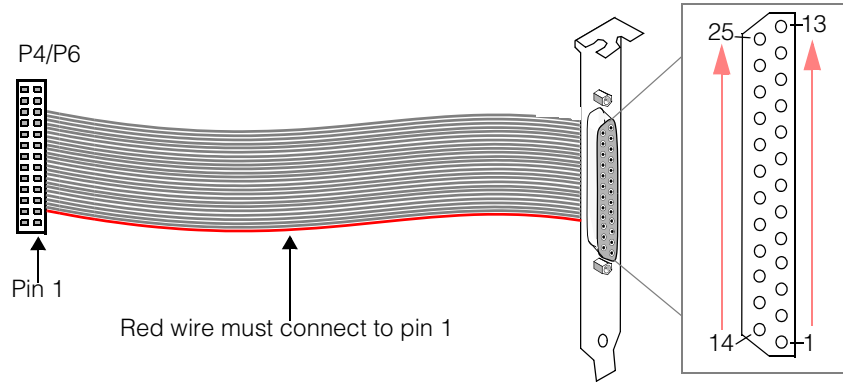

Figure 9. I/O extension cable, Cognex part number 300-0240

Note

Make sure that the red wire on the I/O extension cable is connected to pin 1 of the P4 or P6 connector. The location of pin 1 is shown in Figure 15 on page 50 (MVS-8601 and MVS-8602) and Figure 16 on page 51 (MVS-8602e).

For your convenience, Cognex provides the *General-Purpose I/O Kit*, which includes two 300-2040 I/O extension cables with faceplates, two DB-25 extension cables, and two 25-pin terminal blocks.

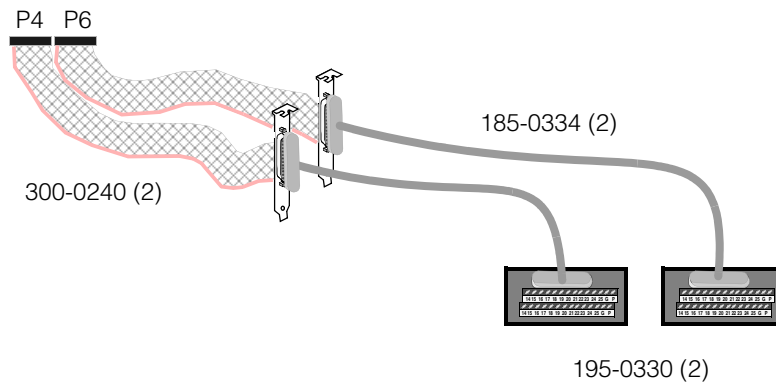

Figure 10. General-Purpose I/O Kit Components

The 195-0330 terminal block terminals correspond exactly to the DB-25 pin numbers on the 300-0240 faceplate; terminal 1 on the terminal block connects to pin one on the DB-25, terminal 2 to pin 2, and so on.

Loadable Software I/O Configurations

The MVS-8600 supports different combinations of trigger, strobe, and encoder pinouts, depending on the currently loaded software I/O configuration. See your Cognex software package's documentation to learn how to load I/O configurations onto the MVS-8600.

Each I/O configuration corresponds to a different cable that you use to connect the MVS-8600 to the I/O connection module, as summarized in Table 3.

Software I/O option	Cable to I/O connection module	Camera configuration	Encoder type	MVS-8602, MVS-8602e only
1 (default)	300-0539	One area scan	n/a	
		Two area scan	n/a	yes
		One line scan	LVDS	
		One line scan, one area scan	LVDS	yes
		Two line scan (shared encoder)	LVDS	yes
2	300-0540	One area scan	n/a	
		One line scan	TTL	
		Two area scan	n/a	yes
		Two line scan	TTL x 2	yes
		One line scan, one area scan	TTL	yes
3	300-0538	Two line scan	LVDS x 2	yes

Table 3. Software I/O configuration options

Take note of the following points about the information in Table 3.

- The cables in Table 3 connect to the Hirose HR10 connector on the MVS-8600 faceplate, and to the DB-26 connector on the I/O connection module.
- The LEDs on the top panel of the I/O connection module illuminate differently for each cable when power is applied, to show which jacks are enabled by that cable.
- The default I/O configuration option for both VisionPro and CVL software is 1.

Specifying the I/O Software Option

For VisionPro, you specify the I/O software option by specifying the following options in the *visionpro.ini* file:

1. **IOConfig = LVDS** (*Default)
2. **IOConfig = TTL**
3. **IOConfig = DualLVDS**

For CVL, I/O options 1, 2, and 3 are associated with the following classes:

1. **cclO8600LVDS** (*Default)
2. **cclO8600TTL**
3. **cclO8600DualLVDS**

For more information, refer to the CVL or VisionPro documentation.

Connecting Triggers

Triggers for I/O Options 1 and 2

For I/O connection options 1 and 2, you can wire your trigger device either to the TTL pins or to the opto-isolated pins on the I/O connection module. The choice between TTL and opto-isolated wiring is independent of the currently loaded I/O configuration option.

Use the pins described in Table 4 and illustrated in Figure 11.

	TTL	Opto-isolated
Trigger for camera port 0	T0, GND	T0+, T0-
Trigger for camera port 1	T1, GND	T1+, T1-

Table 4. Trigger wiring for I/O options 1 and 2

Signal names are explained in *MVS-8600 Signal Names* on page 61.

Note

If you use an I/O configuration that supports TTL trigger input lines, and you are not using the I/O connection module to break out the trigger lines from the MVS-8600, then do not leave the input line floating. Connect either ground or a +5 V signal to the input line while the frame grabber is powered on to prevent the generation of spurious trigger signals.

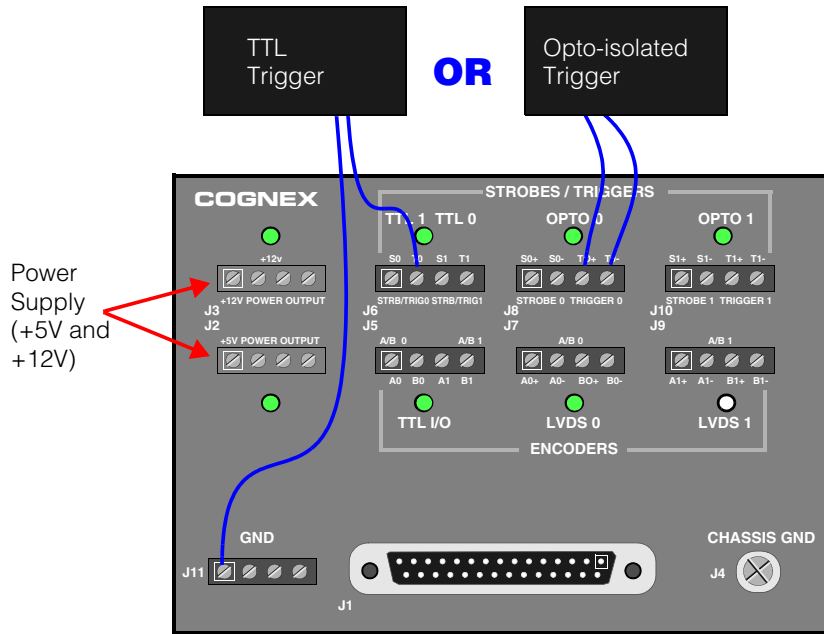

Figure 11. Trigger wiring for I/O options 1 and 2

A larger view of the top plate of the I/O connection module is in Figure 24 on page 71.

Note

Trigger devices requiring +5VDC or +12VDC power can be connected to the power supply terminals (upper-left corner) on the I/O module, as long as the total draw for all devices does not exceed 1A. The power supply terminals draw power from the MVS-8600 through the Hirose connector. (The external power connector must be connected, as shown in Figure 4 on page 17.)

Triggers for I/O Option 3

For I/O option 3, all the pins on the I/O connection module are devoted to encoder connections. In this case, connect the I/O extension cable (300-0240), and optionally a terminal block (195-0330) from the *General-Purpose I/O Kit*, to the frame grabber's P4 connector, and connect the trigger device's wires as shown in Figure 12 and described in Table 5.

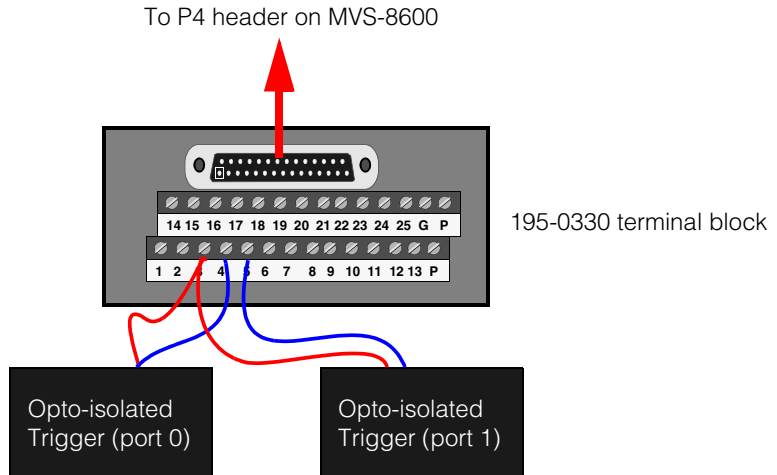

Figure 12. Wiring triggers for I/O option 3

Note Power supply wiring for trigger devices is not shown in Figure 12. The 195-0030 terminal block does not supply power.

Pins on DB-25 or 195-0330 terminal block connected to P4

	Opto +	Opto –
Trigger for camera port 0	3	4
Trigger for camera port 1	3	5

Table 5. Opto-isolated trigger wiring for I/O option 3

For I/O option 3, triggers must be opto-isolated. Opto-isolated inputs on P4 share the anode (+) pin between two lines. See *Programmable Line Input Circuitry* on page 73 for a wiring diagram for this connection type.

Connecting Strobes

Strobes for I/O Options 1 and 2

For I/O connection options 1 and 2, you can wire your strobe device either to the TTL pins or to the opto-isolated pins on the I/O connection module. The choice between TTL and opto-isolated wiring is independent of the currently loaded I/O configuration option.

Use the pins described in Table 6 and illustrated in Figure 13.

	TTL	Opto-isolated
Strobe for camera port 0	S0, GND	S0+, S0-
Strobe for camera port 1	S1, GND	S1+, S1-

Table 6. Strobe wiring for I/O options 1 and 2

Signal names are explained in *MVS-8600 Signal Names* on page 61.

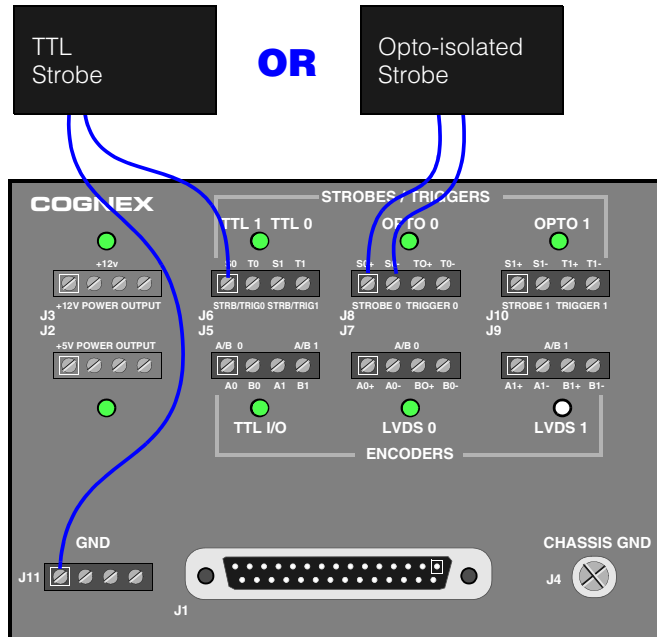

Figure 13. Strobe wiring for I/O options 1 and 2

A larger view of the top plate of the I/O connection module is in Figure 24 on page 71.

Connecting Encoders for Line Scan Cameras

The MVS-8600 supports both LVDS differential encoders and TTL open collector encoders for use with line scan cameras. Chapter 3 provides an overview of encoders, while Table 11 on page 40 and Table 12 on page 41 detail the specific encoder types supported by the MVS-8600.

Wires from encoders are always connected to jacks on the I/O connection module. Use the pins described in Table 7 to connect encoder devices.

	I/O Option 1 Cable 300-0539	I/O Option 2 Cable 300-0540	I/O Option 3 Cable 300-0538
Encoder for camera port 0	A0+, A0-, B0+, B0- Jack J7	A0, B0, GND Jacks J5, J11	A0+, A0-, B0+, B0- Jack J7
Encoder for camera port 1	If second camera is present, it shares encoder signals with camera 0.	A1, B1, GND Jacks J5, J11	A1+, A1-, B1+, B1- Jack J9

Table 7. Encoder wiring

Connecting Programmable I/O Devices

The MVS-8600 provides the following combinations of programmable opto-isolated input and output lines for use by your vision processing application.

	Number of Input Lines			Number of Output Lines		
	On P4	On P6	Total	On P4	On P6	Total
I/O Option 1	4	4	8	4	4	8
I/O Option 2	4	4	8	4	4	8
I/O Option 3	2	4	6	2	4	6

Table 8. Programmable I/O connection options

Programmable Input Lines

To connect I/O devices to one or more programmable input lines, first connect an I/O extension cable (part number 300-0240), and optionally a DB-25 extension cable (185-0334) and terminal block (195-0330), to the frame grabber's P4 and/or P6 connector. Use Table 9 to determine the pins to use on the 300-0240 cable's DB-25 connector or on the 195-0330 terminal block.

Signal Name	P4 Pin (DB-25 and terminal block)	P6 Pin (DB-25 and terminal block)	Notes
OPTO_IN_0_1+	3		
OPTO_IN_0-	4		Not available with I/O option 3
OPTO_IN_1-	5		
OPTO_IN_2_3+	11		
OPTO_IN_2-	12		
OPTO_IN_3-	13		
OPTO_IN_4_5+		3	
OPTO_IN_4-		4	
OPTO_IN_5-		5	
OPTO_IN_6_7+		11	
OPTO_IN_6-		12	
OPTO_IN_7-		13	

Table 9. DB-25 connection for opto-isolated input lines

Opto-isolated inputs on P4 and P6 share the anode (+) pin between two lines. See *Programmable Line Input Circuitry* on page 73 for a wiring diagram for this connection type.

Programmable Output Lines

To connect I/O devices to one or more programmable output lines, first connect an I/O extension cable (part number 300-0240), and optionally a DB-25 extension cable (185-0334) and terminal block (195-0330), to the frame grabber's P4 and/or P6 connector. Use Table 10 to determine the pins to use on the 300-0240 cable's DB-25 connector or on the 195-0330 terminal block.

Signal Name	P4 Pin (DB-25 and terminal block)	P6 Pin (DB-25 and terminal block)	Notes
OPTO_OUT_0-	16		
OPTO_OUT_0+	15		Not available with I/O option 3
OPTO_OUT_1-	2		
OPTO_OUT_1+	1		
OPTO_OUT_2-	10		
OPTO_OUT_2+	9		
OPTO_OUT_3-	23		
OPTO_OUT_3+	22		
OPTO_OUT_4-		16	
OPTO_OUT_4+		15	
OPTO_OUT_5-		2	
OPTO_OUT_5+		1	
OPTO_OUT_6-		10	
OPTO_OUT_6+		9	
OPTO_OUT_7-		23	
OPTO_OUT_7+		22	
TAP24V_0-3	14		
TAP24V_4-7		14	
GND	17		

Table 10. DB-25 connection for opto-isolated output lines

Signal Name	P4 Pin (DB-25 and terminal block)	P6 Pin (DB-25 and terminal block)	Notes
GND	19		
GND	21		
GND		17	
GND		19	
GND		21	

Table 10. DB-25 connection for opto-isolated output lines

You must supply 5 to 24 V input power to the appropriate TAP24V line. Use an external power source to take maximum advantage of the opto-isolation circuitry's signal isolation.

Connect the device's + wire to the OPTO_OUT_*n*+ line. Connect the external power supply's ground terminal to the OPTO_OUT_*n*- line.

The programmable opto-isolated output circuitry is further described in *Programmable Line Output Circuitry* on page 74.

I/O Connection Reference Tables

Table 11 summarizes the I/O connection options, sorted by desired camera and encoder type.

You want to connect ...				Use these settings				Ports on I/O Module		Prog I/O Opto pairs
Cameras	Encoder type	Trig	Str	8601 cam port	8602 cam port	I/O config	Cable to I/O box	Trigger, Strobe	Encoder	
Area scan	--	√	√	0	0 or 1	1	300-0539	J6 or J8	--	8
				0	0 or 1	2	300-0540	J6 or J8	--	8
Line scan	LVDS	√		0	0	1	300-0539	J6 or J8	J7	8
Line scan	TTL	√		0	0	2	300-0540	J6 or J8	J5	8
Area scan	--	√	√	--	0	1	300-0539	J6 or J8+J10	--	8
Area scan	--	√	√	--	0	2	300-0540	J6 or J8+J10	--	8
Line scan	Shared	√		0	1	1	300-0539	J6 or J8	J7	8
Line scan	LVDS	√								
Line scan	TTL	√		--	0	2	300-0540	J6 or J8+J10	J5	8
Line scan	TTL	√								
Line scan	LVDS	√		--	0	3	300-0538	300-0240 to P4	J7+J9	6
Line scan	LVDS	√								
Line scan	TTL			Not supported						
Line scan	TTL			Not supported						
Line scan	TTL			Not supported						
Line scan	LVDS	√		--	0	1	300-0539	J6 or J8+J10	J7	8
Area scan	--	√	√							
Line scan	TTL	√		--	0	2	300-0540	J6 or J8+J10	J5	8
Area scan	--	√	√							

Table 11. MVS-8600 I/O connection by camera and encoder type

Table 12 shows the same information, sorted by I/O configuration type.

I/O Configuration		Connection Options (AS=area scan, LS=line scan)					Ports on I/O Module		Prog. I/O opto pairs		
I/O config	Cable to I/O box	Camera	Encoder	Trig	Str	8601 cam port	8602 cam port	Trigger, Strobe		Encoder	
1	300-0539	Area scan	--	√	√	0	0 or 1	J6 or J8	--	8	
		Line scan	LVDS	√		0	0	J6 or J8	J7	8	
		Area scan	--	√	√		0		J6 or J8+J10	--	8
		Area scan	--	√	√		1				
		Line scan	LVDS	√			0		J6 or J8+J10	J7	8
		Area scan	--	√	√		1				
2	300-0540	Line scan	LVDS	√			0	J6 or J8+J10	J7	8	
		Line scan (shared encoder)	(shared)	√			1				
		Area scan	--	√	√	0	0 or 1	J6 or J8	--	8	
		Line scan	TTL	√		0	0	J6 or J8	J5	8	
		Area scan	--	√	√		0		J6 or J8+J10	--	8
		Area scan	--	√	√		1				
3	300-0538	Line scan	TTL	√			0	J6 or J8+J10	J5	8	
		Line scan	TTL	√			1				
		Line scan	TTL	√			0		J6 or J8+J10	J5	8
		Area scan	--	√	√		1				
		Line scan	LVDS	√			0		300-0240 to P4	J7+J9	6
Line scan (two encoders)	LVDS	√			1						

Table 12. MVS-8600 I/O connection by I/O configuration (1, 2, or 3)

This chapter describes the hardware for the Cognex MVS-8600 family of frame grabbers.

This chapter contains the following sections:

- *MVS-8600 Components* on page 44 describes the components that make up the MVS-8600.
- *Mechanical Specifications* on page 50 provides a physical description of the MVS-8600, including information about mechanical layout, environmental requirements, and safety standards.
- *Standards Compliance* on page 54 describes the international electrical standards to which the MVS-8600 conforms.
- *Electrical Specifications* on page 55 describes the electrical interface to the MVS-8600, including power requirements, connector pinouts, and circuit descriptions.
- *I/O Connection Module for the MVS-8600* on page 68 describes the Cognex accessory module that provides wire connection terminals for I/O to and from the MVS-8600.
- *Circuit Logic Diagrams* on page 73 provides reference circuit diagrams to help you connect I/O devices.

Notes on Terminology

Throughout this manual:

- The term MVS-8600 or MVS-8600 series refers to all of the frame grabbers described in this document.
- The terms MVS-8601 and MVS-8602 are used when discussing features specific to frame grabbers that plug into the PCI bus.
- PCI refers to 32-bit PCI card slots, while PCI-X refers to 64-bit (extended) PCI card slots.
- The term MVS-8602e is used to describe the board that plugs into the PCI Express bus.
- PCIe is sometimes used to refer to the PCI Express bus.
- Frame grabber names are sometimes abbreviated, dropping the MVS- prefix. For example, 8600, 8602 and 8602e.

MVS-8600 Components

This section describes MVS-8600 series frame grabbers and their components.

MVS-8600 Series Overview

The MVS-8600 series frame grabbers consist of three frame grabber boards that plug into your PC. The MVS-8601 and MVS-8602 plug into the PCI bus and the MVS-8602e plugs into the PCI Express bus. The MVS-8601 has one camera port and can support one camera. The MVS-8602 and MVS-8602e have two camera ports and can support one or two cameras each. This is depicted graphically in the following diagram.

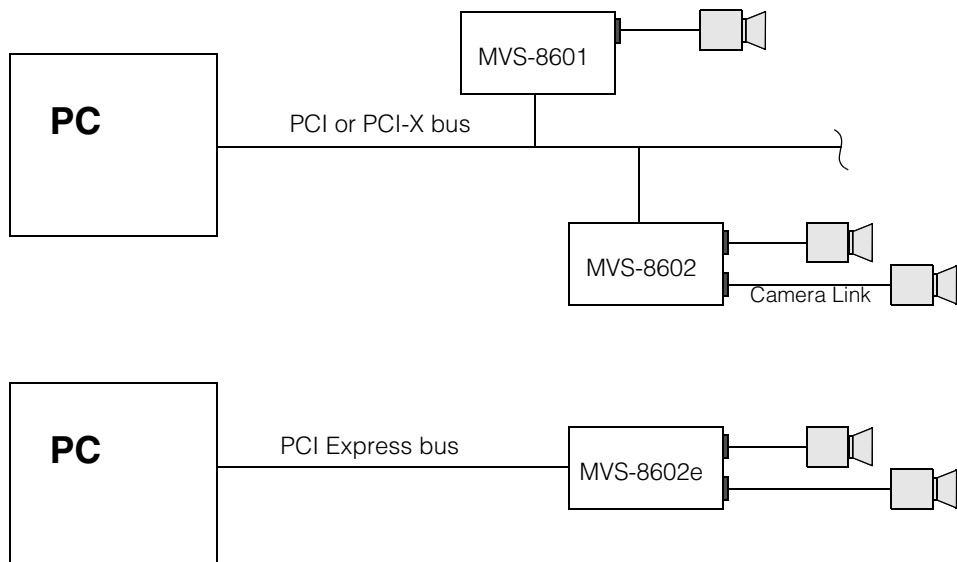

Figure 14. MVS-8600 overview

The MVS-8600 series frame grabbers are different from other Cognex frame grabbers in that they support only the Camera Link communications interface, a special digital high speed serial link between a frame grabber and a digital camera. A special frame grabber, cable and camera are required to use the Camera Link connection. Camera Link is an industry standard connection between digital cameras and frame grabbers.

The MVS-8601 and MVS-8602 were developed first and support the basic functionality of the 8600 series. The MVS-8602e was developed later and include enhanced functionality with new API features. Programs written for the 8601 and 8602 (PCI

versions) will also run on 8602e (PCIe versions) but must first be recompiled. Programs written for the 8602e that use new enhanced functionality will run on the 8602 but any software executing enhanced functionality is ignored.

The following table describes the functional differences between the MVS-8601/MVS-8602 and the MVS-8602e.

Functionality	MVS-8601 and MVS-8602 (PCI)	MVS-8602e (PCIe)
Medium Camera Link	No, Supports only Base Camera Link	Supports Base Camera Link and Medium Camera Link
Onboard Memory	48 MB - 8601 48 MB - 8602	128 MB
Maximum Bandwidth (sustained)	300 MB/sec	360 MB/sec
Encoder Resolution	1x encoder resolution only	1x, 2x or 4x encoder resolution
Trigger on Encoder Offset	Not supported	Supported
Ignore Encoder Between Acquires	Not supported	Supported
Lookup Table (LUT)	Shared LUT on MVS-8602	Independent LUTs (1 per channel)

Table 13. MVS-8600 functional differences

PCI Bus Interface

The PCI bus interface of the MVS-8601 and MVS-8602 is a universal voltage, 32-bit/64-bit, 33/66 MHz interface that conforms to the PCI 2.3 standard. The voltage, data path width and clock speed used by the MVS-8601 and MVS-8602 is dependent on the slot the frame grabber is plugged in to. These factors are discussed in detail in *Selecting an MVS-8601 or MVS-8602 PCI Slot* on page 13.

PCI Express Bus Interface

The MVS-8602e has an x4 PCI Express bus interface. PCI Express card slots come in four sizes: x1, x4, x8 and x16. See Figure 3 on page 16.

The MVS-8602e has an x4 bus interface and cannot physically fit into an x1 card slot, but will physically fit into any of the other three card holders. The MVS-8602e cards will operate when plugged into x8 or x16 slots, but depending on your PC's motherboard, the card may only operate at x1 speed (one fourth of normal speed).

Note Some PC motherboards support x4 speed for x4 cards connected to x8 or x16 slots, but other motherboards drop to x1 speed. Cognex recommends that you place the MVS-8602e in an x4 slot. If you need to use an x8 or x16 slot, consult the BIOS manufacturer’s documentation to determine whether the BIOS supports x4 or x1 operation under these conditions.

Video Acquisition Interface

The video acquisition interface on the MVS-8600 series has the following characteristics:

- Supports one (MVS-8601) or two (MVS-8602 and MVS-8602e) base configuration cameras that use the Camera Link communication interface
- Supports area scan cameras
- Supports line scan cameras
- Accepts Camera Link *base* and *medium* configuration cameras (Medium configuration cameras are support only by the MVS-8602e)

Specifications

There are three models in the MVS-8600 series. Two models, the MVS-8601 and MVS-8602 plug into the PCI bus, and the MVS-8602e plugs into the PCI Express bus. Table 14 lists their specifications and distinguishes the features of the four models.

Feature	PCI bus		PCI Express Bus
	MVS-8601	MVS-8602	MVS-8602e
Cameras connected at same time	1	2	2
Asynchronous image acquisitions	1	2	2
Camera Link configurations supported	1 base	1 or 2 base	1 or 2 base or 1 medium
Onboard SDRAM for FIFO buffer	48 MB	48 MB	128 MB
Bus interface	PCI Universal 32/64-bit, 33/66 MHz		PCI Express, x4

Table 14. Specifications for the MVS-8600 series

Feature	PCI bus		PCI Express Bus
	MVS-8601	MVS-8602	MVS-8602e
Bus interface options	66 MHz operation in 64-bit (long) PCI slots or PCI-X slots. 33 MHz operation in standard 32-bit (short) PCI slots (Board extends past end of slot)		Any x4 PCIe slot or any x8 or x16 slot that is x4-compatible
Bus transfer rate	533 MB/sec peak, 300 MB/sec sustained		1 GB/sec peak, 360 MB/sec sustained
Camera Link acquisition rate	Up to 85 MHz per input		Up to 85 MHz per input
Camera scan modes	Area scan or line scan		Area scan or line scan
Frame buffer features	Low-latency input/output Multi-tap combining Up to 64Kx64K single image for area scan and line scan. Up to 64KxInfinity line scan (when using FreeRunning TriggerModel)		Low-latency input/output Multi-tap combining Up to 64Kx64K single image for area scan and line scan. Up to 64KxInfinity line scan (when using FreeRunning TriggerModel)
Lookup Tables	One 256 KB entry table	Two 256 KB entry tables	Two 512 KB entry tables
Acquired monochrome image depth	8 bits per pixel is supported. (That is, you cannot create an acquisition FIFO using greater than 8-bit monochromatic video format.)		8, 10, 12, 14, and 16 bits per pixel are supported.
Supports RGB color cameras	Yes		Yes
Color/monochrome data conversion	RGB or monochrome target formats with various depths and data packing options		RGB or monochrome target formats with various depths and data packing options
Parallel I/O configurations	Three, software loadable		Three, software loadable

Table 14. Specifications for the MVS-8600 series

Feature	PCI bus		PCI Express Bus
	MVS-8601	MVS-8602	MVS-8602e
Number of programmable I/O lines (depends on I/O configuration loaded)	8 inputs, 8 outputs or 6 inputs, 6 outputs		8 inputs, 8 outputs or 6 inputs, 6 outputs
Programmable I/O line connection type	Opto-isolated		Opto-isolated
Hardware trigger lines	1	2	2
Hardware strobe lines	1	2	2
Wiring options for trigger and strobe lines	TTL or opto-isolated		TTL or opto-isolated
Encoder input lines (for line scan cameras)	1 x 2-phase	2 x 2-phase	2 x 2-phase
Encoder types supported	TTL or LVDS differential +5 V maximum output		TTL or LVDS differential +5 V maximum output
Maximum encoder frequency	10 MHz		10 MHz
Camera power provided by MVS-8600	+12 V @ 1.0 A (+5 V @ 1.0 A optional)		+12 V @ 1.0 A (+5 V @ 1.0 A optional)
Camera power protection	PolySwitch resettable fuses		PolySwitch resettable fuses
Board power requirements (independent of camera power)	+5 V @ 3.0 A		+5 V @ 3.0 A
Board dimensions	PCI short card 168 x 107 mm		PCI short card 168 x 107 mm
Operating range, temperature	0° to 70° C		0° to 70° C
Operating range, humidity	Up to 95% non-condensing		Up to 95% non-condensing

Table 14. Specifications for the MVS-8600 series

Feature	PCI bus		PCI Express Bus
	MVS-8601	MVS-8602	MVS-8602e
FCC	Class A		Class A
CE	Class A, RoHS Compliant		Class A, RoHS Compliant

Table 14. Specifications for the MVS-8600 series

Support for I/O Devices

MVS-8600 series frame grabbers communicate with devices such as strobes, triggers, encoders, sensors, LEDs, and programmable controllers over parallel signal interface lines.

A Hirose HR10 connector on the frame grabber faceplate provides access to trigger, strobe, and encoder lines. Two 26-pin IDC headers on the board provide access to the same signals on the Hirose connector plus access to eight opto-isolated input lines and eight opto-isolated output lines.

Mechanical Specifications

This section describes the mechanical layout, connectors, environmental requirements, and shipment packaging for the MVS-8600 series frame grabbers.

Component Diagrams

The MVS-8601 and MVS-8602 cards are short length PCI cards, measuring 6.6 x 4.2 inches (168 x 107 mm), and occupying a single PCI bus slot. The MVS-8602e is a short length PCI Express card measuring 6.6 x 4.2 inches (168 x 107 mm), and occupying a single PCI Express x4 slot.

Figure 15 shows the connectors on an MVS-8602 circuit board and Figure 16 shows a similar diagram for the MVS-8602e.

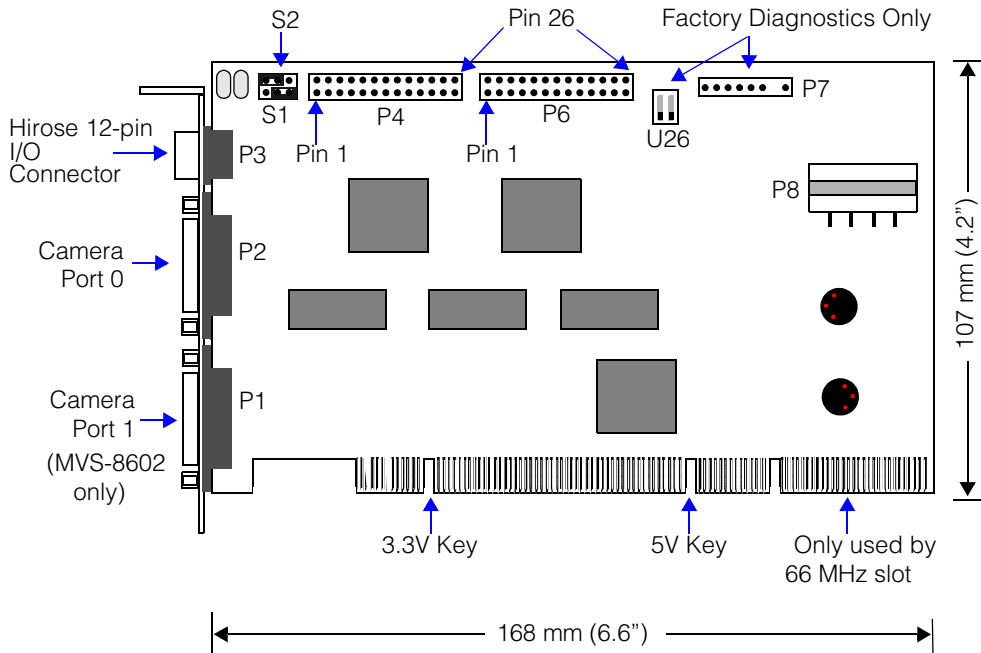

Figure 15. MVS-8602 component location diagram

The MVS-8601 has a single camera port 0 in the same position as camera port 0 in figure above, and does not have the second camera port 1. In all other ways, the MVS-8601 has the same layout as the MVS-8602.

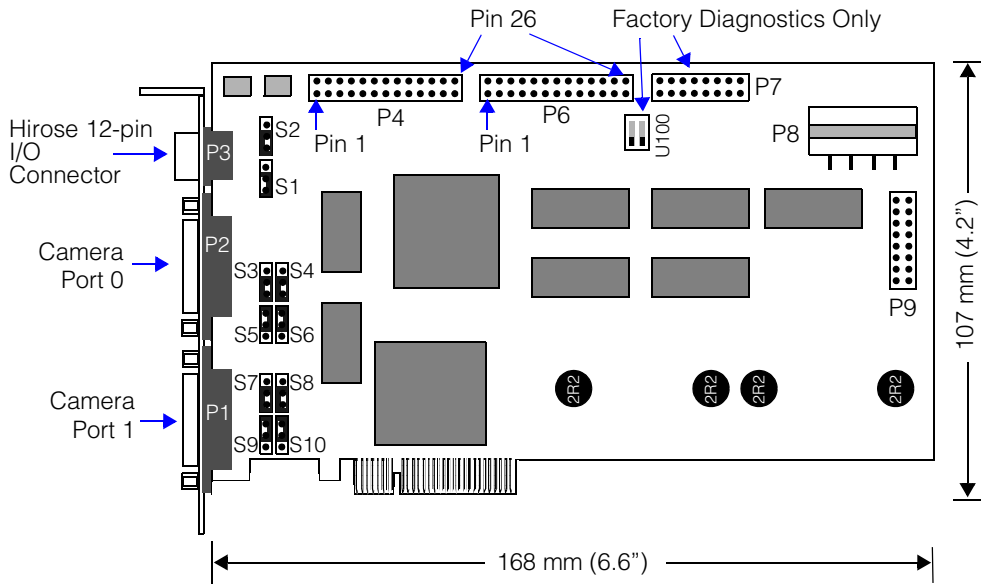

Figure 16. MVS-8602e component location diagram

Connector Summary

MVS-8600 frame grabbers have the following connectors on the faceplate:

- One or two standard Camera Link camera connectors, which are MDR-26 female connectors, 3M part number 10226-6212VC. The MVS-8601 has one connector, and the MVS-8602 and MVS-8602e have two connectors. These ports connect to cables with a 3M 101nn-3000VE connector or equivalent. The pin numbering and pinout of the camera connector are described in *Camera Connector* on page 58.
- One Hirose HR10-10R-12S female receptacle. This connector brings out trigger, strobe, and encoder signal lines to the faceplate. It is intended to be used with a Cognex parallel I/O cable connecting to the Cognex I/O Connection Module (part number 800-5885-1), as described in *Hirose HR10 Connector P3* on page 62.

MVS-8600 frame grabbers have the following jacks on the circuit board:

- Jacks P4 and P6 are 26-pin IDC headers that each bring out half the opto-isolated signal lines, plus a duplication of the signal lines brought out on the Hirose HR10 connector. One or both of these headers can be connected to Cognex I/O cable 300-0240 to carry its signal lines to the PC's back panel. Jacks P4 and P6 are described beginning in *26-Pin IDC Connector P4* on page 63.
- Jacks P7 and P9 are connectors for factory test equipment. Do not use these jacks in any way. Note that the MVS-8602e has P7 and P9 connectors and the MVS-8601 and MVS-8602 have only the P7 connector.
- Jack P8 is a Molex power connectors that accepts a standard PC disk drive power plug from the PC's power supply.

Jumper Summary

MVS-8600 frame grabbers have the following jumpers (also called switches) on the circuit board:

- Jumper positions S1 and S2 determine the power level (+5 V or +12 V) carried on the V_CAM0 and V_CAM1 output lines. S1 and S2 are described in more detail in *Power Output Selection Jumpers S1 and S2* on page 55.
- Jumper positions S3 through S6 and S7 through S10 are reserved for future use. These jumpers are discussed further in *Jumpers S3-S10* on page 57.
- The dual DIP switch block at board position U26 for the MVS-8601/MVS-8602 and at board position U100 for MVS-8602e is for factory diagnostics only. Do not change these switches from their OFF position.

Environmental Requirements

Table 15 lists the environmental requirements for the MVS-8600. These specifications are for the environment inside the PC where the frame grabber is installed. (Note that these are the same requirements as shown in Table 14 on page 46).

	Operating Range
Temperature	0° to 70° C
Humidity (non-condensing)	Up to 95%

Table 15. Environmental requirements

Shipping

All MVS-8600 frame grabbers are shipped in protective packaging and antistatic bags. Save all packing materials in case you need to ship your board to another location.

Standards Compliance

The MVS-8600 series meet the following worldwide standards for safety, electromagnetic compatibility, and electrostatic sensitivity.

International

The MVS-8600 series comply with the following electromagnetic emissions standards:

- United States Code of Federal Regulations Part 15: Federal Communications Commission Class A radio frequency emissions standard
- European Union emissions standard EN55022:1994+ A1:1995+ A2:1997
- Japanese VCCI standard
- Australia and New Zealand standard 3548

European Community

MVS-8600 series frame grabbers are in conformance with the EN61326:1998 Council Directive on immunity for measurement, control, and laboratory equipment, encompassing the following tests:

- EN61000-4-2:1995
- EN61000-4-3:1998
- EN61000-4-4:1995
- EN61000-4-5:2001
- EN61000-4-6:1996
- EN61000-4-8:1998
- EN61000-4-11:1994

MVS-8600 series frame grabbers are in conformance with the following Council Directive on electromagnetic emissions:

- EN61000-3-2:2000
- EN61000-3-3:2000

The manufacturer of the MVS-8600 is:

Cognex Corporation
One Vision Drive
Natick, MA 01760

The European representative is:

Cognex France
Immeuble Le Patio
104 Avenue Albert 1er
92563 Rueil Malmaison
France

Electrical Specifications

This section describes the electrical specifications of the MVS-8600 series, including power requirements and signal descriptions.

Power Requirements

MVS-8600 boards draw +5 V power from the PCI bus or PCI Express bus. Current draw is up to 3.0 A. The maximum current draw occurs during board power-up.

The +12 V power for cameras is drawn either:

1. From an external power supply as specified by the camera's manufacturer.
2. From the MVS-8600 by connecting to the +12 V and/or +5 V jacks of the MVS-8600 I/O connection module. (See Figure 24 on page 71). In this case:
 - If a disk drive power plug from the host PC's power supply is connected to the MVS-8600 P8 jack, up to 1.0 A can be drawn (all cameras).
 - If a disk drive power plug from the host PC's power supply is not connected to the MVS-8600 P8 jack, up to 0.5 A can be drawn (all cameras).
3. From a newer MVS-8602e by using a PoCL cable from the frame grabber to the camera. The two bullets above apply for this case also. See the section *Power over Camera Link (PoCL)* on page 26 for information about PoCL.

Power Output Selection Jumpers S1 and S2

The jumper blocks at board positions S1 and S2 determine the power (+5 V or +12 V) carried by the camera power pins V_CAM0 and V_CAM1. The configuration is slightly different between MVS-8601/MVS-8602 and MVS-8602e boards. The jumper blocks are discussed in sections *MVS-8601 and MVS-8602 Power Selection Jumpers* and *MVS-8602e Power Selection Jumpers* below.

MVS-8601 and MVS-8602 Power Selection Jumpers

The default settings set at the factory are shown in Figure 17.

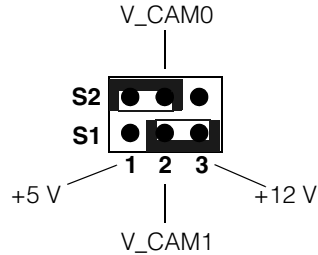

Figure 17. Default settings for MVS-8601 and MVS-8602 S1 and S2

Caution

When using the Cognex I/O connection module (part number 800-5885-1), jumpers S1 and S2 must remain in their factory default positions.

The following table shows the meanings of the jumper setting positions.

	Jumper over 1-2	Jumper over 2-3
S2	+5 V for V_CAM0 (default)	+12 V for V_CAM0
S1	+5 V for V_CAM1	+12 V for V_CAM1 (default)

MVS-8602e Power Selection Jumpers

The default settings set at the factory are shown in Figure 18.

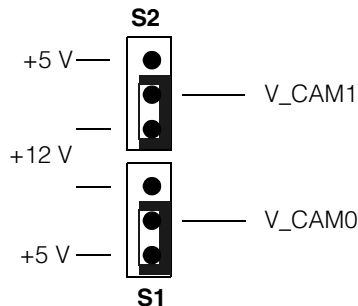

Figure 18. Default settings for MVS-8602e S1 and S2

Caution When using the Cognex I/O connection module (part number 800-5885-1), jumpers S1 and S2 must remain in their factory default positions.

The following table shows the meanings of the jumper setting positions.

	Jumper over +5	Jumper over +12
S1	+5 V for V_CAM0 (default)	+12 V for V_CAM0
S2	+5 V for V_CAM1	+12 V for V_CAM1 (default)

Jumpers S3-S10

Jumpers S3 through S10 are reserved for future use. You should leave these jumpers set in the factory default position as shown in Figure 19 below.

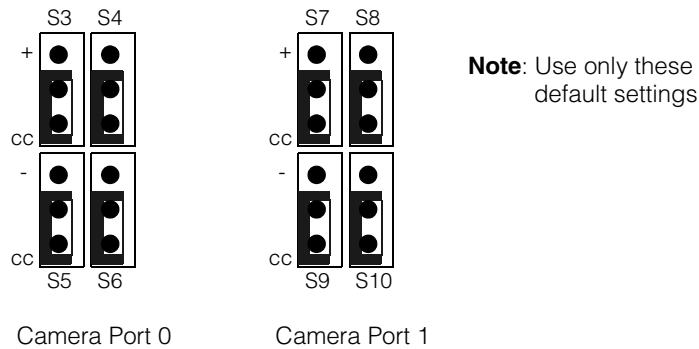

Figure 19. Jumpers S3-S10 factory default settings

Resettable Fuses

There are no user-replaceable fuses on MVS-8600 series frame grabbers.

Lines of the power input connector P8 are protected by PolySwitch resettable fuses.

If an over-voltage or over-current condition occurs on these lines, the PolySwitch fuse trips, opening the circuit. You only need to remove the device that caused the condition, correct the overcurrent condition, wait a few minutes for the PolySwitch circuitry to cool down, then plug the device back in. The fuse resets itself.

DIP Switches

There is a two-position DIP switch at location U26 for the MVS-8601 and MVS-802 and at location U100 for the MVS-8602e. This switch is used for factory diagnostics and should not be changed from the default (OFF) setting.

Camera Connector

Cameras are attached to MVS-8600 frame grabbers through one or two 26-pin MDR high-density Mini-D connectors on the faceplate. These connectors are defined in the *Camera Link Specification*.

Pin numbering for the camera connectors is shown in Figure 20. The orientation is looking straight into the connector with the frame grabber board held horizontally, facing the faceplate, with the Hirose connector on the left.

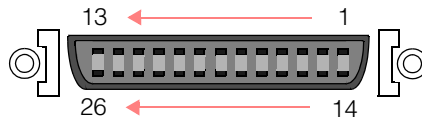

Figure 20. Pin numbering of camera connector

Pinouts for the two connectors on dual port boards are identical. Camera Link signals are low voltage differential signals, where each signal requires two wires. The two parts of each signal pair are designated with + and – symbols.

The pinout for the camera connector is shown in Table 16. This table provides the pin numbering and signal name conventions defined in the *Camera Link Specification*, organized by signal name.

In 2007, the Camera Link specification was updated to provide support for PoCL (Power over Camera Link). This revision redefined the use of pins 1, 13, 14 and 26. These pins were previously tied to the cable shield but are now used to provide two +12 V power sources from the frame grabber to the camera, and two power return ground lines. The following tables note the old and new use of these pins. See *Power over Camera Link (PoCL)* on page 26 for additional information.

Pin	Signal Name	Pin	Signal Name	Pin	Signal Name
1	Inner shield or +12V power (PoCL)	9	XCLK+	17	CC2+
14	Inner shield or +12V return (PoCL)	21	X3–	4	CC2–

Table 16. Pinout for Camera Link camera connectors, by signal name

Pin	Signal Name	Pin	Signal Name	Pin	Signal Name
25	X0-	8	X3+	16	CC3-
12	X0+	20	SerTC+	3	CC3+
24	X1-	7	SerTC-	15	CC4+
11	X1+	19	SerTFG-	2	CC4-
23	X2-	6	SerTFG+	13	Inner shield or +12V return (PoCL)
10	X2+	18	CC1-	26	Inner shield or +12V power (PoCL)
22	XCLK-	5	CC1+		

Table 16. Pinout for Camera Link camera connectors, by signal name

Table 17 provides the pinout of the camera connector in pin number order.

Pin	Signal Name	Pin	Signal Name	Pin	Signal Name
1	Inner shield or +12V power (PoCL)	10	X2+	19	SerTFG-
2	CC4-	11	X1+	20	SerTC+
3	CC3+	12	X0+	21	X3-
4	CC2-	13	Inner shield or +12V return (PoCL)	22	XCLK-
5	CC1+	14	Inner shield or +12V return (PoCL)	23	X2-
6	SerTFG+	15	CC4+	24	X1-
7	SerTC-	16	CC3-	25	X0-
8	X3+	17	CC2+	26	Inner shield or +12V power (PoCL)
9	XCLK+	18	CC1-		

Table 17. Pinout for Camera Link camera connectors, by pin number

Camera Cables

If your Camera Link camera uses a standard MDR-26 Camera Link connector and does not use PoCL power source, use one of the following Cognex cables to connect an MVS-8600 camera port to your camera:

- 185-0241, 5 meter Camera Link cable
- 185-0242, 10 meter Camera Link cable

If your camera is equipped with a MiniCL connector (all CIS and Sony Camera Link cameras, as well as the Hitachi KP-F200SCL and KP-F500SCL cameras have MiniCL connectors), use these Cognex cables:

- 185-1001, 5 meter Miniature Camera Link cable
- 185-1002, 10 meter Miniature Camera Link cable

In 2007, the Camera Link specification added support for the PoCL feature which allows the frame grabber to provide +12 V power to a PoCL camera through the camera cable. The change uses four camera cable lines that were previously tied to the cable shield, providing two +12 V power supply lines and two ground returns. As described in the section *Determining if Your MVS-8602e Supports PoCL* on page 27, newer MVS-8602e boards support the use of PoCL.

If you are using a PoCL camera equipped with a MiniCL connector, use this Cognex cable:

- 185-1093R, 5 meter high-flex PoCL Miniature Camera Link cable

Cognex Camera Link cables have thumbscrews on one end and a click-lock connector on the other end.

Note Connect the click-lock connector to the frame grabber.
 Connect the thumbscrew connector to your Camera Link camera.

Parallel I/O Connectors and Cables

Parallel I/O on the MVS-8600 series includes:

- Dedicated trigger input lines, either TTL or opto-isolated, one per camera port.
- Dedicated strobe output lines, either TTL or opto-isolated, one per camera port.
- Dedicated input lines for encoders for use with line scan cameras, one set per camera port. Both TTL and LVDS differential encoders are supported.
- Six or eight pairs of programmable opto-isolated input lines for use by your application.

- Six or eight pairs of programmable opto-isolated output lines for use by your application.
- Parallel I/O configurations are software-defined, as described in *Loadable Software I/O Configurations* on page 31.

Parallel I/O signals are brought out to the Hirose HR10 connector on the frame grabber's faceplate, and to two 26-pin IDC headers on the MVS-8600 main board labeled P4 and P6. The following sections describe these parallel I/O signals.

MVS-8600 Signal Names

MVS-8600 signal names are described in this manual and in Cognex software documentation using the following code.

Code	Reference
T_n	Dedicated trigger signal line for camera channel <i>n</i>
S_n	Dedicated strobe signal line for camera channel <i>n</i>
A_n, A_n'	Encoder channel A connection for camera channel <i>n</i> . For a TTL type encoder, use <i>A_n</i> and GND. For an LVDS type encoder, use <i>A_n</i> and <i>A_n'</i> .
B_n, B_n'	Encoder channel B connection for camera channel <i>n</i> .
OPTO_IN__m±	Programmable opto-isolated input line, where <i>m</i> is 0 to 7 or 2 to 7, inclusive, depending on the current I/O configuration.
OPTO_OUT__m±	Programmable opto-isolated output line, where <i>m</i> is 0 to 7 or 2 to 7, inclusive, depending on the current I/O configuration.
V_CAM_n	Power output line for camera channel <i>n</i> . Power from these lines is pulled from the frame grabber and can be used as power input for the specified camera. (See Figure 24 on page 71). When PC power is provided at the frame grabber P8 plug, power drawn from these lines must not exceed 1.0 A. If power is not provided at P8, power drawn from these lines must not exceed 0.5 A. Cognex recommends using an independent camera power supply to power your cameras instead of these lines.
TAP24V__{x-y}	Power input line for opto-isolated output circuitry. Apply 5 to 24 V on these lines to power the output lines, as described in <i>Programmable Line Output Circuitry</i> on page 74.

Table 18. Signal name codes for MVS-8600

Hirose HR10 Connector P3

The Hirose HR10-10R-12S connector on the faceplate carries trigger, strobe, and encoder signals, as well as camera power and ground lines. This connector is designed to be used with a Cognex cable connecting to the I/O Connection Module, part number 800-5885-1.

The pin numbering for the Hirose connector on the MVS-8600 faceplate is shown in Figure 21.

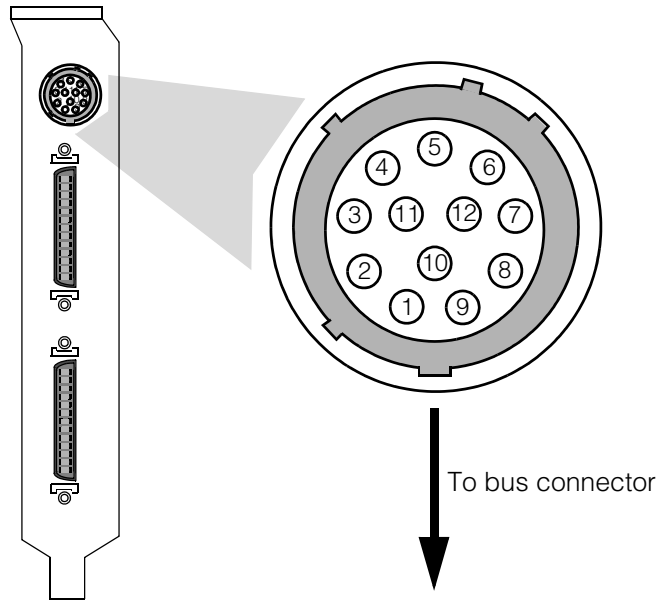

Figure 21. Pin numbering for Hirose HR10 connector

All signals on the Hirose HR10 connector are duplicated on either the P4 or P6 connectors, or on both.

Connect wires from trigger, strobe, and encoder devices to the I/O Connection Module as described in *Connecting Parallel I/O Devices* on page 29. Cognex does not recommend connecting device wiring directly to the Hirose HR10 connector.

Table 19 below shows the pinout of this connector, and shows where the same signals are found on the P4 and P6 connectors. Table 19 is for cable reference only.

Signal Name	Pin on Hirose HR10	Same Signal on this pin of P4	Same Signal on this pin of P6	Notes
GND	1	8, 12, 16, 26	8, 12, 16, 26	
+V_CAM0	2	10	10	
A0	3	11		
A0' or A1	4	13		
B0	5	22		
B0' or B1	6	24		
S1 or A1'	7		13	MVS-8602 and MVS-8602e only
T0 or B1	8		22	
T1 or B1'	9		24	MVS-8602 and MVS-8602e only
GND	10	8, 12, 16, 26	8, 12, 16, 26	
+V_CAM1	11	15	15	
S0 or A1	12		11	

Table 19. Pinout of Hirose HR10 connector on the faceplate

On some pins, the signal varies according to the currently loaded software I/O configuration, as described in *Loadable Software I/O Configurations* on page 31. Signal names in Table 19 are described in *MVS-8600 Signal Names* on page 61.

26-Pin IDC Connector P4

The P4 and P6 connectors are the only connection point for the board's programmable opto-isolated input and output lines. Half the programmable input and output line pairs are on P4, while the other half are on P6.

Figure 22 shows the pin numbering of the P4 and P6 connectors.

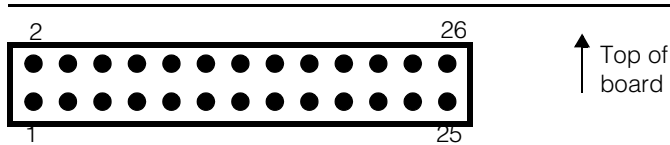

Figure 22. Pin numbering of the P4 and P6 connectors

Connect wires from devices to the DB-25 connector on cable 300-0240, and optionally a terminal block (195-0330) from the *General-Purpose I/O Kit*, as described in *Connecting Parallel I/O Devices* on page 29. Do not connect device wires directly to the P4 connector.

Table 20 shows the pinout of the P4 connector in pin number order, and shows where the same signals are found on the Hirose HR10 connector. Table 20 is for cable reference only.

Signal Name	Pin on P4	Pin on DB-25 of 300-0240 and 195-0330 terminal block	Same signal also found on this pin
OPTO_OUT_1+	1	1	
TAP24V_0-3	2	14	
OPTO_OUT_1-	3	2	
OPTO_OUT_0+	4	15	
OPTO_IN_0_1+	5	3	
OPTO_OUT_0-	6	16	
OPTO_IN_0-	7	4	
GND	8	17	Hirose 1, 10
OPTO_IN_1-	9	5	
+V_CAM0	10	18	Hirose 2
A0	11	6	Hirose 3
GND	12	19	Hirose 1, 10
A0' or A1	13	7	Hirose 4

Table 20. Pinout of P4 connector

Signal Name	Pin on P4	Pin on DB-25 of 300-0240 and 195-0330 terminal block	Same signal also found on this pin
NC - Do Not Use	14	20	
+V_CAM1	15	8	Hirose 11
GND	16	21	Hirose 1, 10
OPTO_OUT_2+	17	9	
OPTO_OUT_3+	18	22	
OPTO_OUT_2-	19	10	
OPTO_OUT_3-	20	23	
OPTO_IN_2_3+	21	11	
B0	22	24	Hirose 5
OPTO_IN_2-	23	12	
B0' OR B1	24	25	Hirose 6
OPTO_IN_3-	25	13	
GND	26	Not connected	Hirose 1, 10

Table 20. Pinout of P4 connector

On some pins, the signal varies according to the currently loaded software I/O configuration, as described in *Loadable Software I/O Configurations* on page 31. Signal names in Table 20 are described in *MVS-8600 Signal Names* on page 61.

26-Pin IDC Connector P6

The P6 connector brings out opto-isolated input and output lines, as well as several signals also present on the Hirose HR10 connector.

Connect wires from devices to the DB-25 connector on cable 300-0240, and optionally a terminal block (195-0330) from the *General-Purpose I/O Kit*, as described in *Connecting Parallel I/O Devices* on page 29. Do not connect device wires directly to the P6 connector.

The pin numbering of the P6 connector is show in Figure 22 on page 64.

Table 21 below shows the pinout of the P6 connector in pin number order, and shows where the same signals are found on the Hirose HR10 connector. Table 21 is for cable reference only.

Signal Name	Pin on P6	Pin on DB-25 of 300-0240 and 195-0330 terminal block	Same signal also found on this pin	Notes
OPTO_OUT_5+	1	1		
TAP24V_4-7	2	14		
OPTO_OUT_5-	3	2		
OPTO_OUT_4+	4	15		
OPTO_IN_4_5+	5	3		
OPTO_OUT_4-	6	16		
OPTO_IN_4-	7	4		
GND	8	17	Hirose 1, 10	
OPTO_IN_5-	9	5		
+V_CAM0	10	18	Hirose 2	
S0 or A1	11	6	Hirose 3	
GND	12	19	Hirose 1, 10	
S1 or A1 ¹	13	7	Hirose 7	MVS-8602/ MVS-8602e only
NC - Do Not Use	14	20		
+V_CAM1	15	8	Hirose 11	
GND	16	21	Hirose 1, 10	
OPTO_OUT_6+	17	9		
OPTO_OUT_7+	18	22		
OPTO_OUT_6-	19	10		

Table 21. Pinout of P6 connector

Signal Name	Pin on P6	Pin on DB-25 of 300-0240 and 195-0330 terminal block	Same signal also found on this pin	Notes
OPTO_OUT_7-	20	23		
OPTO_IN_6_7+	21	11		
T0 or B1	22	24	Hirose 8	
OPTO_IN_6-	23	12		
T1 or B1'	24	25	Hirose 9	MVS-8602/ MVS-8602e only
OPTO_IN_7-	25	13		
GND	26	Not connected	Hirose 1, 10	

Table 21. Pinout of P6 connector

On some pins, the signal varies according to the currently loaded software I/O configuration, as described in *Loadable Software I/O Configurations* on page 31. Signal names in Table 21 are described the following section.

Line Numbering

The correspondence between trigger lines, strobe lines, encoder lines, and camera channels is one-to-one. That is, T0, S0, A0, A0', B0, and B0' all refer to the camera connected to camera port 0.

Likewise, T1, S1, A1, A1', B1, and B1' all refer to the camera connected to camera port 1.

Image acquisition can be software or hardware triggered. If hardware triggers are enabled on the MVS-8600, a pulse from a trigger device connected to the T0 line initiates an image acquisition on the camera connected to camera channel 0. If strobes are enabled, a strobe connected to the S0 line is fired. Likewise, if enabled on the MVS-8602 and MVS-8602e, a trigger pulse on T1 acquires an image on camera channel 1 and (if enabled) fires the strobe connected to S1.

If the camera connected to camera port 0 is a line scan camera, it relies on the encoder input on lines A0 and B0 (with A0' and B0' for LVDS encoders). Likewise, a line scan camera on camera port 1 relies on encoder input on lines A1 and B1 (with A1' and B1').

I/O Connection Module for the MVS-8600

Use the I/O connection module, part number 800-5885-1, to connect device wires from triggers, strobes, and encoders to the MVS-8600.

Capabilities of the I/O connection module include:

- Provides wire connection terminals providing +5 V and +12 V power drawn from the MVS-8600 at up to 1.0 A.
- Provides wire connection terminals corresponding to the signals present on the MVS-8600 Hirose HR10 connector.
- LEDs are lit according to which input cable is connected, showing the terminal block jacks available with that cable.
- DIN standard rail mounting.

Layout of I/O Connection Module

Figure 23 shows the layout of the I/O connection module.

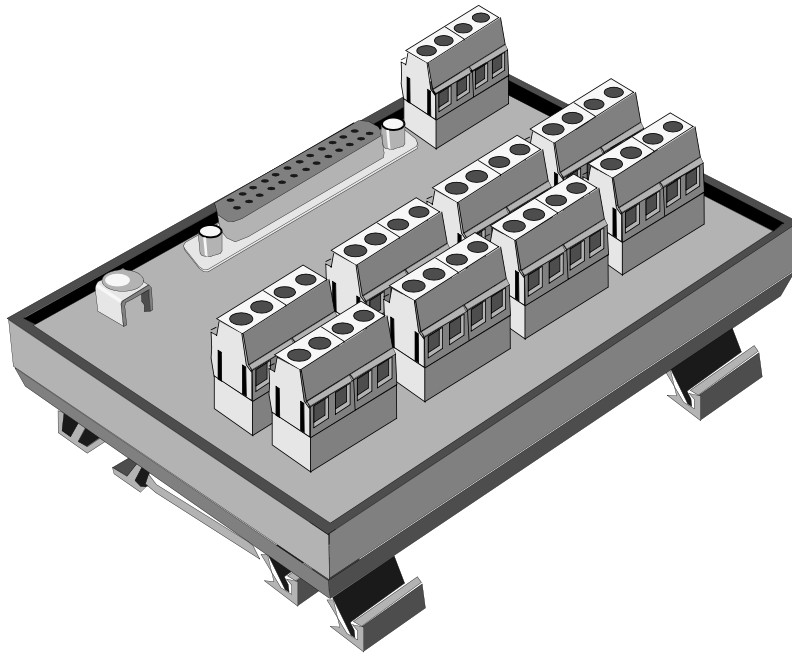

Figure 23. I/O connection module for the MVS-8600

The DB-25F connector provides a connection from the MVS-8600 through one of the Cognex cables listed in Table 23 on page 70.

Specifications for the I/O Connection Module

Table 22 lists the mechanical and electrical specifications for the I/O connection module, part number 800-5885-1.

Specification	Description
Dimensions	4.688 in (width) 11.91 cm 2.375 in (height) 6.03 cm 3.25 in (depth) 8.26 cm
Mounting	#3 DIN rail mountable
Operating Voltage (Field Side)	5 V to 24 V DC
Power	+5 V DC and +12 V DC @ 1 A, supplied from the MVS-8600
Maximum Output Current	100 mA (sink or source for strobes)
Triggers ON State Voltage Drop	0.4 V DC @ 10 mA 2.6 V DC @ 24 mA
Triggers OFF State Leakage Current	10 μ A maximum @ 10 V DC
Strobe Output Delay	ON: 15 μ Sec @ 5.0 mA OFF: 30 μ Sec @ 5.0 mA
Input Resistance	~1000 Ohms
Input State Current	ON: 3.5 to 24 mA OFF: 500 μ A
Trigger Input Delay	ON: 5 μ Sec @ 2.0 mA OFF: 4 μ Sec @ 2.0 mA
Field Wiring Size	26 to 12 AWG

Table 22. I/O connection module specifications

Specification	Description
Terminal Block Torque	Maximum 0.8 (7) N-M (in-lbf)
Environmental	Operating Temperature: 0 to 50° C Storage Temperature: -20 to 85° C Relative Humidity: 5 to 95 percent non-condensing

Table 22. I/O connection module specifications

Cables from MVS-8600 to I/O Module

The cable you use to connect the Hirose port to the I/O connection module corresponds to the currently loaded software I/O configuration, as described in *Loadable Software I/O Configurations* on page 31. Table 23 summarizes the I/O configuration options and corresponding cables.

Cognex Cable	Software I/O Config	Camera and Encoders Supported	I/O Module Jacks Enabled by this Cable
300-0539	1	Area scan cameras or line scan cameras with LVDS encoder, or two line scan cameras with a shared encoder	J6, J7, J8, J10
300-0540	2	Line scan cameras with TTL encoders	J5, J6, J8, J10
300-0538	3	Two line scan cameras with LVDS encoders	J7, J9

Table 23. PIO cables to connect MVS-8600 to I/O connection module

Each parallel I/O cable from Table 23 enables the appropriate set of connections jacks on the I/O module. LEDs associated with the enabled jacks are illuminated when the PC containing the frame grabber is powered on. The LEDs for jacks J2 and J3 are illuminated with all cables.

Note For all three I/O cables, the board jumpers S1 and S2 *must* remain in their factory default positions for the correct voltages to appear on jacks J2 and J3 of the I/O connection module. The jumpers are described in *Power Output Selection Jumpers S1 and S2* on page 55.

The use of each jack on the I/O connection module is described in Table 24 on page 71.

Wiring Devices to the I/O Connection Module

Figure 24 shows the layout of the top panel of the I/O connection module, and illustrates the terminal labels. The signal name abbreviations are explained in Table 18 on page 61.

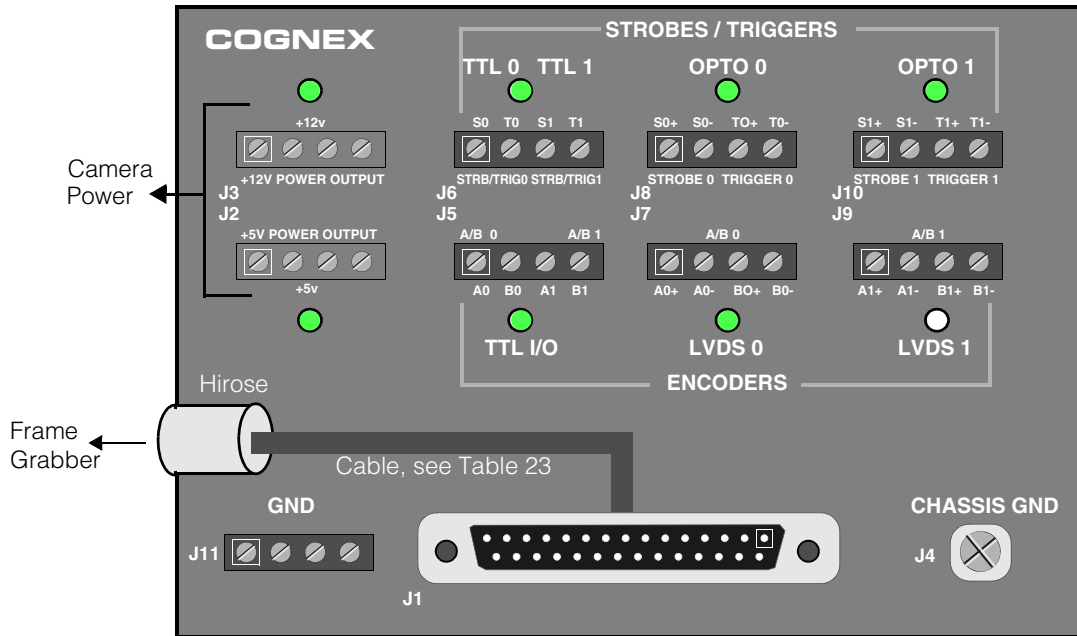

Figure 24. Wiring connections on I/O Connection Module

The connection jacks of the I/O connection module each contain four screw terminals that accept the connection of bare wires from devices. The use of each jack is explained in Table 24. The second column refers to the software I/O configuration options and associated PIO cables, as described in Table 23 on page 70.

Jack	I/O Config Option	Connection
J1	All	DB-25 jack accepts one of the PIO cables listed in Table 23 on page 70.
J2	All	Supplies +5 V power for cameras at up to 1.0 A drawn from the MVS-8600.

Table 24. Connection jacks of the I/O connection module

Jack	I/O Config Option	Connection
J3	All	Supplies +12 V power for cameras at up to 1.0 A drawn from the MVS-8600.
J4	All	Connect a wire to chassis ground.
J5	2	Connect encoder channels A and B for TTL encoders associated with line scan cameras on both camera ports.
J6	1, 2	TTL wiring point to connect trigger input and strobe output for both camera ports. Use either this TTL jack or the opto-isolated jacks J8 -J10 for triggers and strobes, but not both.
J7	1, 3	Connect encoder channels A and B for an LVDS encoder associated with a line scan camera on camera port 0.
J8	1, 2	Opto-isolated wiring point to connect trigger input and strobe output for camera port 0. Use either this opto-isolated jack or the TTL jack J6 for trigger and strobe, but not both.
J9	3	Connect encoder channels A and B for an LVDS encoder associated with a line scan camera on camera port 1.
J10	1, 2	Opto-isolated wiring point to connect trigger input and strobe output for camera port 1. Use either this opto-isolated jack or the TTL jack J6 for trigger and strobe, but not both.
J11	All	Ground terminals for TTL ground and power ground.

Table 24. Connection jacks of the I/O connection module

Circuit Logic Diagrams

This section provides circuit diagrams and descriptions illustrating how to wire parallel I/O devices to the MVS-8600.

Programmable Line Input Circuitry

Figure 25 illustrates the connection of input devices to the opto-isolated input circuitry for the programmable lines OPTO_IN_0 through OPTO_IN_7. These lines are present on the P4 and P6 jacks of the MVS-8600, and are brought out to the host PC's back panel with cable 300-0240.

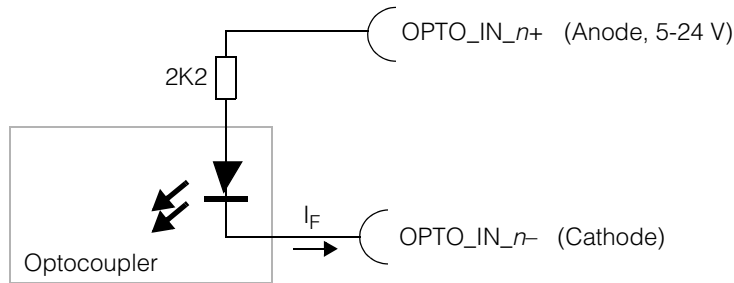

Figure 25. Opto-isolated input circuitry for programmable lines

Note

To take maximum advantage of the signal isolation provided by the opto-isolation circuitry, the programmable input lines should be powered by an external power supply, not by the MVS-8600.

The eight opto-isolated input lines are grouped into four pairs, with each pair sharing a common anode (+) pin, but with individual cathode (-) pins. Table 25 shows the groupings and pin numbers of the programmable input line pairs.

Signal Name	P4 Pin	P4's 300-0240 Pin on DB-25	P6 Pin	P6's 300-0240 Pin on DB-25	Notes
OPTO_IN_0_1+	5	3			These lines not available with I/O option 3
OPTO_IN_0-	7	4			
OPTO_IN_1-	9	5			
OPTO_IN_2_3+	21	11			
OPTO_IN_2-	23	12			

Table 25. Grouping of opto-isolated input lines

Signal Name	P4	P4's 300-0240	P6	P6's 300-0240	Notes
	Pin	Pin on DB-25	Pin	Pin on DB-25	
OPTO_IN_3-	25	13			
OPTO_IN_4_5+			5	3	
OPTO_IN_4-			7	4	
OPTO_IN_5-			9	5	
OPTO_IN_6_7+			21	11	
OPTO_IN_6-			23	12	
OPTO_IN_7-			25	13	

Table 25. Grouping of opto-isolated input lines

The first four input pairs (lines 0 through 3) are on the P4 connector.

The second four input pairs (lines 4 through 7) are on the P6 connector.

Programmable Line Output Circuitry

Figure 26 illustrates the connection of output devices to the opto-isolated output circuitry for the programmable lines OPTO_OUT_0 through OPTO_OUT_7.

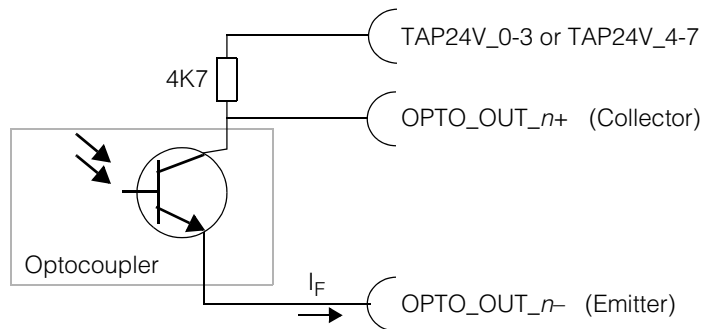

Figure 26. Opto-isolated output circuitry for programmable lines

Note To take maximum advantage of the signal isolation provided by the opto-isolation circuitry, the programmable output lines should be powered by an external power supply, not by the MVS-8600.

The collector (+) pin for each line has a pull-up resistor to the TAP24V_*n-n* common rail for each group of four lines, which must be connected to the desired operational voltage between 5 and 24 V. Supply a source of 5 to 24 volt power to the appropriate TAP24V_*n-n* line. Use TAP24V_0-3 on P4 to supply output lines 0 through 3; use TAP24V_4-7 on P6 to supply output lines 4 through 7.

Connect the emitter (–) pin for each line to the ground terminal of the external voltage source.

Table 26 shows the pin numbers of the programmable output line pairs.

Signal Name	P4 P4's 300-0240		P6 P6's 300-0240		Notes
	Pin	Pin on DB-25	Pin	Pin on DB-25	
OPTO_OUT_0–	6	16			These lines not available with I/O option 3
OPTO_OUT_0+	4	15			
OPTO_OUT_1–	3	2			
OPTO_OUT_1+	1	1			
OPTO_OUT_2–	19	10			
OPTO_OUT_2+	17	9			
OPTO_OUT_3–	20	23			
OPTO_OUT_3+	18	22			
OPTO_OUT_4–			6	16	
OPTO_OUT_4+			4	15	
OPTO_OUT_5–			3	2	
OPTO_OUT_5+			1	1	
OPTO_OUT_6–			19	10	
OPTO_OUT_6+			17	9	
OPTO_OUT_7–			20	23	
OPTO_OUT_7+			18	22	
TAP24V_0-3	2	14			
TAP24V_4-7			2	14	

Table 26. Pin numbers of opto-isolated output lines

	P4	P4's 300-0240	P6	P6's 300-0240	
Signal Name	Pin	Pin on DB-25	Pin	Pin on DB-25	Notes
GND	8	17			
GND	12	19			
GND	16	21			
GND			8	17	
GND			12	19	
GND			16	21	

Table 26. Pin numbers of opto-isolated output lines

I/O Connection Module Input Circuitry

Figure 27 shows a typical input schematic to help you determine how to wire your trigger input devices to the opto-isolated $Tn+$ and $Tn-$ pins of the J8 and J10 jacks on the I/O connection module.

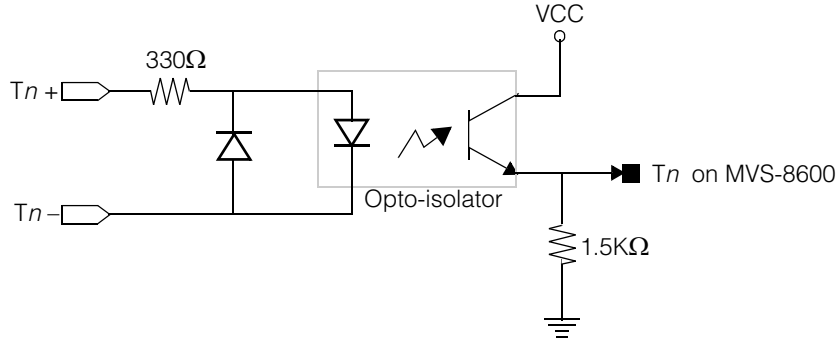

Figure 27. Schematic for opto-isolated trigger input on I/O connection module

I/O Connection Module Output Circuitry

Figure 28 shows a typical output schematic to help you determine how to wire strobe output devices to the opto-isolated S_{n+} and S_{n-} pins of the J8 and J10 jacks of the I/O connection module.

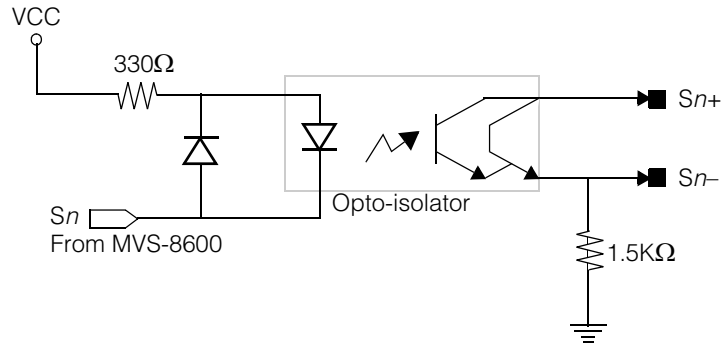

Figure 28. Schematic for opto-isolated strobe output on I/O connection module

I/O Connection Module Adds Conversion Delay

The opto-isolated trigger and strobe connection options on the I/O connection module converts the digital TTL signals from the MVS-8600 into opto-isolated signal pairs. The opto-isolation circuitry of the I/O module adds a very small delay compared to a pure TTL signal. For comparison, the response time of a typical TTL signal is about 1 microsecond.

A strobe device will receive its signal about 2.0 microseconds slower when connected to the opto-isolated jacks of the I/O module than when connected to the TTL jacks.

A signal from a trigger device connected to the opto-isolated jack will be delayed from reaching the MVS-8600 by about 1.5 microseconds, compared to the same device going through the TTL jack.

A delay of this small magnitude is not visible to the naked eye, but may have a cumulative effect when multiplied over many rapid image acquisitions. Take this delay into account when calculating your maximum image processing throughput if you plan to use the opto-isolated jacks of the I/O connection module.

Using Encoders with Line Scan Cameras

3

An encoder is an electromechanical transducer that converts rotary or linear motion into electrical signals. Encoders are used to determine speed, velocity, distance, position, or direction. Examples of encoder types vary widely, and include equipment as different as an airplane's altimeter or a computer's trackball.

When used with a line scan camera, an encoder provides a mechanism to keep track of the position and direction of the scene under the camera lens. Line scan cameras capture one row of pixels at a time, and build up an image by combining hundreds of rows into an image.

Encoders and the MVS-8600 Series

MVS-8600 series frame grabbers use encoder inputs to:

- Monitor the rate of motion of the scene being imaged by a line scan camera
- Detect a direction change, or a halt in the scene motion

The MVS-8600 cannot acquire an image from a line scan camera without an encoder input. It is the encoder input that the frame grabber uses to calculate the rate at which lines are acquired.

CVL and VisionPro software provide a software-based test encoder that can be used to simulate encoder input for testing and setup, in lieu of a hardware encoder.

In CVL, when **ccEncoderProp::useTestEncoder()** is enabled, the hardware acquires lines as fast as possible without using a hardware encoder input. The **ccEncoderProp::stepsPerLine()** setting is ignored. To introduce a delay between acquisitions of successive lines, you can specify a positive trigger delay value. See the **ccTriggerFilterProp** reference page for information about how to do this.

In VisionPro, the **ICogAcqLineScan.TestEncoderEnabled** and **ICogAcqTriggerFilter.TriggerDelay** properties provide the same capability.

Encoder Characteristics

The design of your vision system will determine the most appropriate encoder type for your application. In general, the encoder type most useful for the machine vision component of a factory automation system is likely to be a *dual-channel quadrature incremental rotary encoder*. The important characteristics of this encoder type are described below:

- A *rotary encoder* measures the number of revolutions of a spinning shaft or tube. You can attach a measuring wheel to the shaft, and place the wheel against a conveyor system to translate the conveyor's linear motion into the encoder's rotary measurements. A rotary encoder's output is specified in cycles per revolution (CPR).
- An *incremental encoder* produces a series of cyclically repeating pulses. One full revolution of a rotary incremental encoder produces the same number of pulses every time. An incremental encoder's important output is the number of cycles produced, not the position of the encoder shaft. (By contrast, an *absolute encoder* produces a unique x-y value, such as a voltage or a binary count, for each mechanical position.)
- A *dual-channel incremental encoder* supplies two sets of incremental output data. One of the two encoder channels generally leads the other by 90 degrees, which puts the two channels in quadrature relationship to each other. By convention, two encoder channels are referred to as channel A and B.
- Incremental encoders might provide an *index pulse* in addition to their A and B channel output. The index pulse provides an absolute reference point for the encoder's spin, referred to as the center, home, or reset position of the encoder. By convention, the index pulse is called the Z channel. The MVS-8600 does not support the index pulse.
- A *quadrature dual-channel encoder* is used for measuring bidirectional motion. Because the two channels are in quadrature relationship (90 degree phase offset), the system can monitor the phase relationship between the two channels to determine the direction of motion.

Encoder Electrical Interface

This section describes the electrical characteristics of encoders that are best suited to, and compatible with, MVS-8600 frame grabbers used in line scan applications. The MVS-8600 is capable of supporting many types of encoders, but not all meet the electrical voltage and signal requirements. There are many types of rotary and linear encoders available with a wide variety of electrical characteristics. Use this section as a

guide when selecting an encoder for your line scan application. This information also describes a solution when the selected encoder does not meet the MVS-8600 encoder input requirements.

It is very important to select an encoder with the proper electrical characteristics. Using an encoder with incompatible electrical characteristics on MVS-8600 frame grabbers may result in damage to the encoder, the frame grabber, or both. The encoder may over-heat and cause intermittent image acquisition problems such as image jitter and encoder overruns that can be very difficult to diagnose.

There are several interface standards used for incremental encoders, such as RS-422, RS-485, LVDS (EIA-644), Push-Pull, Open-Collector, Sink/Source, and various TTL type Line Drivers. Each of these interfaces has a specification for voltage minimum and maximum, current sourcing or sinking limits, cable type and length maximums, as well as numerous industry association standards. These are summarized in Table 27 below.

Specification	LVDS (EIA-644)	RS-422	TTL & 5V Line Driver	Push-Pull & Sink/Source [‡]	Open Collector [‡]
Output current (typ)	< 5 mA	< 150 mA	<100 mA	± 150 mA	20mA
Output Impedance (Ohms)	100 Ω	100 Ω	1 kΩ	Hi-Z	10k (typ)
Output Voltage Range Max (-CMV)	± 600 mV	± 12.0 V	0 to +5.5 V	NA	NA
Input common mode voltage	0 to +2.4V	± 7.0 V	NA	NA	NA
Input (differential) threshold minimum	± 100 mV	± 200 mV	+.3V <> +1.2V	0 to VCC	0 to VCC
Transmission Distance	<30m	<100m	<10m	<50m	<10m

[‡] Not fully tested or verified by Cognex on the MVS-8600

Table 27. Specifications and standards

The MVS-8600 I/O interface is multi-purpose and encompasses LVDS, RS-422, and TTL standards, but provides over voltage protection, without opto-isolation, through the use of a +5 V clamp on the signal interface. This means that the effective operating voltage input is limited to the range 0 V to +5 V. The over-voltage feature protects up to + 30 V input with high current sinking limits (2 Amps maximum). Thus, when the MVS-8600 is operating in TTL mode, it is compatible with TTL line driver encoders and open collector or push/pull interfaces when they operate within the +5 V limit for the encoder signals (such as A, B, Z, and so on).

Additionally, the interface offers the benefits of operating in differential signal mode (a positive and negative signal pair) to increase noise immunity and the signal to noise ratio (SNR), while reducing the effects of glitches and ground bounce in noisy electrical environments. However, some differential encoders may not be directly connected to the I/O without additional circuitry in order to meet the interface voltage and current requirements.

Generally, most differential RS-422 compatible encoders will be compatible as long as all the differential outputs are limited to the range 0 V to +5 V (absolute range referenced to ground) which is often the case when using a +5 V power supply. It is also important to note that the common mode voltage is the average of the voltage between the positive and negative encoder signal pair. Unfortunately, most industrial environments have limited DC power supply sources available, and often +12 V or +24 V is used for encoders, resulting in a much higher voltage for the encoder signal outputs.

For encoders with signal outputs greater than +5 V (absolute reference to ground), the signal needs to be made compliant with the input voltage requirements and properly conditioned, given the effect of the circuit's over voltage clamp.

A simple solution is to utilize a series resistor in the path between each of the encoder signal outputs. The resistor then functions as a voltage attenuation circuit. Its value is determined through Ohm's Law, $Voltage = Current \times Resistance$ and depends on the current loop through the 100 Ohm termination resistor. The wiring schematic is shown in Figure 29 with the added series resistors labeled as R_1 and R_2 .

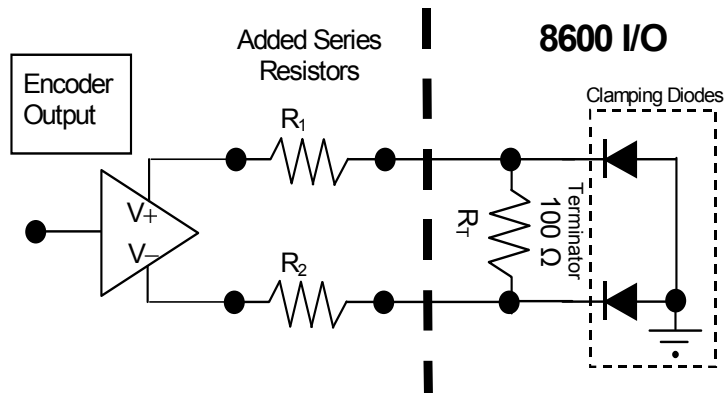

Figure 29. Schematic with series resistors

It is important to realize that the over voltage protection diode will clamp the input voltage to a maximum of +5 V, and as such, there will be a maximum voltage drop across R_1 . (When the polarity is switched, the clamp to ground is -0.3V for R_T). Additionally, in order to maintain balanced impedance for both the encoder positive signal (V_+) and encoder negative signal (V_-), both R_1 and R_2 should be the same value. In this case, the differential receiver circuit voltage input can be as low as +0.5 V (\pm

200mV range with some small margin). Putting all this information together it is then possible to calculate the resistor value required to provide the correct signal voltage with minimum current draw.

For the scenario of a 0 V to +12 V differential voltage signal pair (V_+ minus $V_- = +12$ V), the resistor value is determined as shown.

$$V = I \cdot R$$

$$(R_1) = \frac{12V - 0.5V}{\frac{0.5V}{100\Omega}} = \frac{11.5V}{5mA} = 2300\Omega$$

Refer to Table 28 below for the various recommended resistor values, depending on the encoder's signal. It is important to note that, if necessary, line voltage regulators such as a passive decoupling capacitor can be added to the circuitry to bring the common mode voltage into the acceptable range, as given by the absolute range requirement of 0 V to +5 V (referenced to ground).

	Encoder Output Absolute Voltage Range		
Interface option	0 V ... +5 V	0 V ... +12 V	0 V ... +28 V(max)
Series resistors (R_1 , R_2)	None needed	2.3k Ω (kOhms)	5.5k Ω (kOhms)

Table 28. Recommended series resistor values

Connecting Encoders

If your application will use encoder-triggered image acquisition, then you must set up your Cognex software package to be aware of the characteristics of your encoder hardware. Your encoder vendor's documentation provides your encoder's basic characteristics, such as the number of encoder cycles per revolution. Your Cognex software package's documentation includes formulas and examples for translating the encoder's cycles per revolution into the number of encoder steps for each line of image acquired by the line scan camera.

Relationship Between Encoder and Camera Channels

You use a separate encoder for each line scan camera, as explained in Table 29 below.

Encoder Type	Encoder Wiring	Line Scan Camera Connected to
LVDS differential	A0+, A0-, B0+, B0-	Camera port 0
TTL open collector	A0, B0, GND	Camera port 0
LVDS differential	A1+, A1-, B1+, B1-	Camera port 1
TTL open collector	A1, B1, GND	Camera port 1

Table 29. Encoder and camera channel relationships

The one exception is with I/O Configuration 1 where one encoder can be used to drive both camera ports on MVS-8602e. This is known as a *shared encoder* configuration. See *Loadable Software I/O Configurations* on page 31.

Encoder Support Varies With I/O Configuration Loaded

Your Cognex software package provides a method to load different I/O configurations. The loaded configuration determines the number and type of encoders supported.

Loadable I/O configurations are discussed in your Cognex software package's documentation and in *Loadable Software I/O Configurations* on page 31.

Index

Symbols

+12 V power 17, 55

Numerics

800-5885-1 68

8600
see MVS-8600

A

AMD Athlon 12

C

Camera Link 19, 44

camera power 26

caution
do not power on PC before
connecting cameras and
devices 18
electrostatic discharge can
damage 17

chip set 12

circuit diagram
external I/O module, inputs 76
external I/O module, outputs 77

Cognex Corporation
headquarters address 9
web site address 9

color camera 47

component location
on MVS-8600 50

conventions
text style 8

Council Directives 54

E

electrical specifications 55

electromagnetic
compatibility standard 54

electrostatic sensitivity standards 54

environmental requirements 52

European
community standards 54
representative 55

European community standards 54

F

FCC class A 54

fuses
PolySwitch 57

H

humidity 52

I

I/O connection module 71

L

line numbering
trigger and strobe lines 67

M

MVS-8600
component location 50
electrical specifications 55

O

opto-isolated I/O module
delay added by 77
specifications 69

P

part numbers
800-5885-1 68

PC
requirements 12

PCI bus
interface 45

PCI Express bus
interface 45

Pentium 12

pin numbering
camera input port 58

pinout
camera input port 58

PoCL 26, 55

PolySwitch fuse
resetting 57

R

requirements
environmental 52
for host PC 12

S

safety standards 54

specifications
electrical, of MVS-8600 55
environmental, inside host PC 52
for external I/O module 69

standards
electromagnetic compatibility 54
electrostatic sensitivity 54
European community 54
safety 54

strobe 11, 49, 67

T

temperature 52

text styles 8

trigger 11, 49, 67

V

VIA 12

W

web site
Cognex Corporation 9